

VC.192+IN

Lobe knobs

with pointer, Duroplast



MATERIAL

Phenolic based (PF) Duroplast, black colour, glossy finish.

INDEX

Polyamide based (PA) technopolymer.

STANDARD EXECUTIONS

- **VC.192-B+IN**: brass boss, plain blind hole.
- **VC.192-A+IN**: black-oxide steel boss, plain blind hole.

Assembly by means of supplied transversal grub screws UNI 5929-85 (grub screws with hexagon socket and cup end).



ELESA Original design

VC.192+F

Lobe knobs

with flange and pointer, Duroplast



MATERIAL

Phenolic based (PF) Duroplast, black colour, glossy finish.

FLANGE WITH POINTER

Polyamide based (PA) technopolymer, with white indicator line.

STANDARD EXECUTIONS

- **VC.192-B+F**: brass boss, plain blind hole.
- **VC.192-A+F**: black-oxide steel boss, plain blind hole.

Assembly by means of supplied transversal grub screws UNI 5929-85 (grub screws with hexagon socket and cup end).



ELESA Original design

Conversion Table			
1 mm = 0.039 inch			
D			
mm	inch	mm	inch
32	1.26	60	2.36
40	1.57	70	2.76
50	1.97	85	3.35

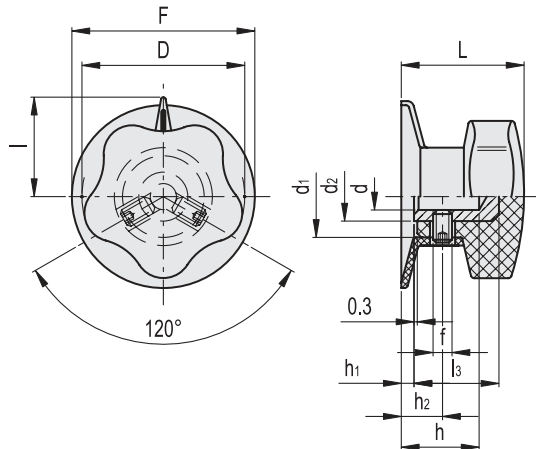
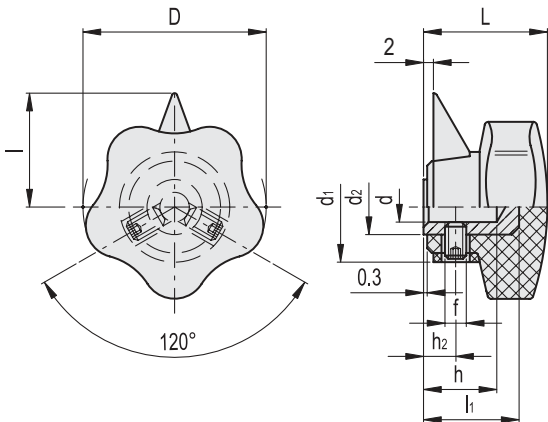

METRIC

Code	Description	D	dH9	L	l	l1	d1	d2	h	h2	f	△
66321	VC.192/40 B-6+IN	40	6	27	25	17	25	14	14	6	M4	37
66431	VC.192/50 A-8+IN	50	8	33	31	25	30	15	20	7	M5	70
66531	VC.192/60 A-8+IN	60	8	37	38	25	32	15	20	7	M5	105
66631	VC.192/70 A-10+IN	70	10	44	45	31	35	18	25	11	M6	150
66711	VC.192/85 A-10+IN	85	10	55	50	38	41	22	25	14	M6	250

METRIC

Code	Description	D	dH9	L	F	l	l3	d1	d2	h	h1	h2	f	△
66211	VC.192/30 B-6+F	32	6	27	36	19	19	19	14	22	3	9	M4	30
66311	VC.192/40 B-6+F	40	6	30	45	24	19	21	14	22	3	9	M4	46
66421	VC.192/50 A-8+F	50	8	36	56	30	25	25	15	23	3	10	M5	70
66521	VC.192/60 A-8+F	60	8	42	70	37	25	27	15	25	5	12	M5	105
66621	VC.192/70 A-10+F	70	10	48	80	42	31	30	18	30	5	16	M6	152



Control elements