

FEATURES

- Two independent differential 2:1 multiplexers
- Guaranteed AC performance over temperature and voltage:
 - DC-to >10.7Gbps data rate throughput
 - <290ps IN-to-Out t_{pd}
 - <70ps t_r / t_f times
- Unique, patent-pending input isolation design minimizes crosstalk
- Ultra-low jitter design:
 - <1ps_{RMS} random jitter
 - <10ps_{pp} deterministic jitter
 - <10ps_{pp} total jitter (clock)
 - <0.7ps_{RMS} crosstalk-induced jitter
- Unique, patent-pending 50 Ω input termination and VT pin accepts DC-coupled and AC-coupled inputs (CML, LVDS, PECL)
- Typical 400mV CML output swing ($R_L = 50\Omega$)
- Internal 50 Ω input termination
- Power supply 2.5V \pm 5% or 3.3V \pm 10%
- -40°C to +85°C temperature range
- Available in 32-pin (5mm \times 5mm) MLF® package



Precision Edge®

DESCRIPTION

The SY58025U features two ultra-fast, low jitter 2:1 differential muxes with a guaranteed maximum data or clock throughput of 10.7Gbps or 7GHz, respectively.

The SY58025U differential inputs include a unique, internal termination design that allows access to the termination network through a VT pin. The device easily interfaces to different logic standards, both AC- and DC-coupled, without external resistor-bias and termination networks. The result is a clean, stub-free, low jitter interface solution. The differential CML output is optimized for 50 Ω environments with internal 50 Ω source termination and a 400mV output swing.

The SY58025U operates from a 2.5V or 3.3V supply and is guaranteed over the full industrial temperature range (-40°C to +85°C). The SY58025U is part of Micrel's Precision Edge® product family.

All support documentation can be found on Micrel's web site at www.micrel.com.

APPLICATIONS

- Data communication systems
- All SONET OC3-OC-768 applications
- All Fibre Channel applications
- All GigE applications

FUNCTIONAL BLOCK DIAGRAM

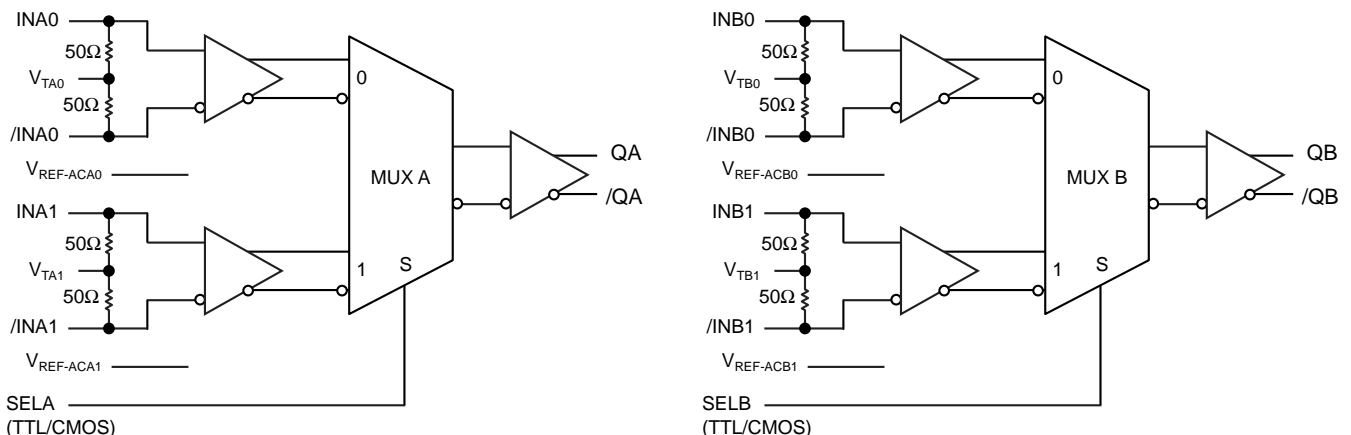

United States Patent No. RE44,134
AnyGate and Precision Edge are registered trademarks of Micrel, Inc.
MicroLeadFrame and MLF are registered trademarks of Amkor Technology, Inc.

PACKAGE/ORDERING INFORMATION

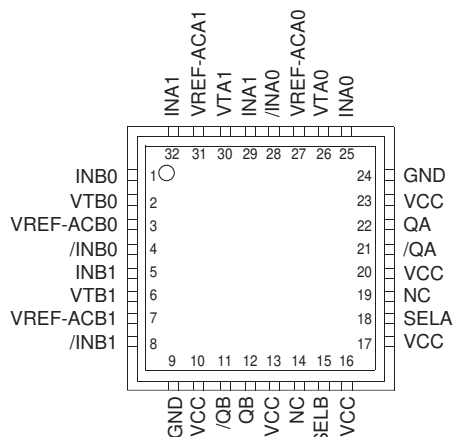

32-Pin MLF® (MLF-32)

Ordering Information⁽¹⁾

Part Number	Package Type	Operating Range	Package Marking	Lead Finish
SY58025UMI	MLF-32	Industrial	SY58025U	Sn-Pb
SY58025UMITR ⁽²⁾	MLF-32	Industrial	SY58025U	Sn-Pb
SY58025UMG ⁽³⁾	MLF-32	Industrial	SY58025Uwith Pb-Free bar-line indicator	Pb-Free NiPdAu
SY58025UMGTR ^(2, 3)	MLF-32	Industrial	SY58025U with Pb-Free bar-line indicator	Pb-Free NiPdAu

Notes:

1. Contact factory for die availability. Dice are guaranteed at T_A = 25°C, DC electricals only.
2. Tape and Reel.
3. Pb-Free package recommended for new designs.

PIN DESCRIPTION

Pin Number	Pin Name	Pin Function
25, 28, 29, 32, 1, 4, 5, 8	INA0, /INA0, INA1, /INA1, INB0, /INB0, INB1, /INB1	Differential Inputs: These input pairs are the differential signal inputs to the device. Inputs accept AC- or DC-coupled differential signals as small as 100mV. Each pin of a pair internally terminates to a V _T pin through 50 Ω . Note that these inputs will default to an indeterminate state if left open. Unused differential input pairs can be terminated by connecting one input to V _{CC} and the complementary input to GND through a 1k Ω resistor. The VT pin is to be left open in this configuration. Please refer to the "Input Interface Applications" section for more details.
26, 30, 2, 6	VTA0, VTA1, VTB0, VTB1	Input Termination Center-Tap: Each side of the differential input pair, terminates to a VT pin. Each V _T pin provides a center-tap to a termination network for maximum interface flexibility. See "Input Interface Applications" section for more details.
18, 15	SELA, SELB	Bank A, Bank B Input Channel Select (TTL/CMOS): These TTL/CMOS-compatible inputs select the inputs to the multiplexers. These inputs are internally connected to a 25k Ω pull-up resistor and will default to a logic HIGH state if left open. Input switching threshold is V _{CC} /2.
27, 31, 3, 7	VREF-ACA0, VREF-ACA1, VREF-ACB0, VREF-ACB1	Reference Output Voltage: These outputs bias to V _{CC} - 1.2V. Connect to the VT pin when AC-coupling the data inputs. Bypass with 0.01 μ F low ESR capacitor to V _{CC} . Maximum current source or sink is 0.5mA. See "Input Interface Applications" section.
10, 13, 16, 17, 20, 23	VCC	Positive Power Supply: Bypass with 0.1 μ F™ \geq 0.01 μ F low ESR capacitors.
22, 21, 12, 11	QA, /QA, QB, /QB	Differential CML Outputs: MUX A and MUX B selected CML outputs. See "Output Interface Applications" section for termination. Refer to the "Truth Table" for logic operation.
9, 24	GND, Exposed pad	Ground: Ground pin and exposed pad must be connected to the same ground plane.
14, 19	NC	Not connected.

Absolute Maximum Ratings⁽¹⁾

Power Supply Voltage (V_{CC}) -0.5V to +4.0V
 Input Voltage (V_{IN}) -0.5V to V_{CC}
 CML Output Voltage (V_{OUT}) $V_{CC}-1.0V$ to $V_{CC}+0.5V$
 Termination Current⁽³⁾
 Source or sink current on V_T pin $\pm 100mA$
 Input Current
 Source or sink current on IN, /IN pin $\pm 50mA$
 Current (V_{REF-AC})
 Source or sink current on V_{REF-AC} ⁽³⁾ $\pm 1.5mA$
 Lead Temperature (soldering, 20 sec.) 260°C
 Storage Temperature Range (T_S) -65°C to +150°C

Operating Ratings⁽²⁾

Power Supply Voltage (V_{CC}) +2.375V to +2.625V
 +3.0V to +3.6V
 Ambient Temperature Range (T_A) -40°C to +85°C
 Package Thermal Resistance⁽⁴⁾
 MLF® (θ_{JA})
 Still-Air 35°C/W
 MLF® (ψ_{JB})
 Junction-to-board 20°C/W

DC ELECTRICAL CHARACTERISTICS⁽⁵⁾

$T_A = -40^\circ C$ to $+85^\circ C$; unless otherwise stated.

Symbol	Parameter	Condition	Min	Typ	Max	Units
V_{CC}	Power Supply	$V_{CC} = 2.5V$ $V_{CC} = 3.3V$	2.375 3.0	2.5 3.3	2.625 3.6	V V
I_{CC}	Power Supply Current	No load, max. V_{CC} . ⁽⁶⁾		115	140	mA
R_{DIFF_IN}	Differential Input Resistance (IN-to-/IN)		80	100	120	Ω
R_{IN}	Input Resistance (IN-to- V_T , /IN-to- V_T)		40	50	60	Ω
V_{IH}	Input High Voltage (IN, /IN)	Note 7	$V_{CC}-1.6$		V_{CC}	V
V_{IL}	Input Low Voltage (IN, /IN)		0		$V_{IH}-0.1$	V
V_{IN}	Input Voltage Swing (IN, /IN)	See Figure 1a.	0.1		1.7	V
V_{DIFF_IN}	Differential Input Voltage Swing $ IN - /IN $	See Figure 1b.	0.2			V
$V_{T\ IN}$	In to V_T (IN, /IN)				1.28	V
V_{REF-AC}	Output Reference Voltage		$V_{CC}-1.3$	$V_{CC}-1.2$	$V_{CC}-1.1$	V

Notes:

1. Permanent device damage may occur if the ratings in "Absolute Maximum Ratings" section are exceeded. This is a stress rating only and functional operation is not implied at conditions other than those detailed in the operational sections of this data sheet. Exposure to absolute maximum ratings conditions for extended periods may affect device reliability.
2. The data sheet limits are not guaranteed if the device is operated beyond the operating ratings.
3. Due to the limited drive capability, use for input of the same package only.
4. Package thermal resistance assumes exposed pad is soldered (or equivalent) to the device's most negative potential (GND) on the PCB. ψ_{JB} uses 4-layer θ_{JA} in still air unless otherwise stated.
5. The circuit is designed to meet the DC specifications shown in the above table after thermal equilibrium has been established.
6. Includes current through internal 50 Ω pull-ups. See Figure 1b.
7. V_{IH} (min) not lower than 1.2V.

CML OUTPUT DC ELECTRICAL CHARACTERISTICS⁽⁷⁾

$V_{CC} = 2.5V \pm 5\%$ or $3.3V \pm 10\%$; $T_A = -40^\circ C$ to $+85^\circ C$; $R_L = 100\Omega$ across each output pair, or equivalent, unless otherwise stated.

Symbol	Parameter	Condition	Min	Typ	Max	Units
V_{OH}	Output High Voltage Q, /Q		$V_{CC}-0.020$		V_{CC}	V
V_{OUT}	Output Voltage Swing Q, /Q	See Figure 1a.	325	400		mV
$V_{DIFF-OUT}$	Differential Output Voltage Swing Q, /Q	See Figure 1b.	650	800		mV
R_{OUT}	Output Source Impedance Q, /Q		40	50	60	Ω

LVTTL/CMOS DC ELECTRICAL CHARACTERISTICS⁽⁷⁾

$V_{CC} = 2.5V \pm 5\%$ or $3.3V \pm 10\%$; $T_A = -40^\circ C$ to $85^\circ C$ unless otherwise stated.

Symbol	Parameter	Condition	Min	Typ	Max	Units
V_{IH}	Input HIGH Voltage		2.0			V
V_{IL}	Input LOW Voltage				0.8	V
I_{IH}	Input HIGH Current		-125		50	μA
I_{IL}	Input LOW Current		-300			μA

Note:

7. The circuit is designed to meet the DC specifications shown in the above table after thermal equilibrium has been established.

AC ELECTRICAL CHARACTERISTICS⁽⁸⁾

V_{CC} = 2.5V ±5% or 3.3V ±10%; T_A = -40°C to +85°C; R_L = 100Ω across each output pair, or equivalent, unless otherwise stated.

Symbol	Parameter	Condition	Min	Typ	Max	Units
f _{MAX}	Maximum Operating Frequency	NRZ Data	10.7			Gbps
		V _{OUT} ≥ 200mV Clock		6		GHz
t _{pd}	Propagation Delay IN-to-Q SEL-to-Q		140		290	ps
			100		400	ps
t _{SKEW}	Input-to-Input Skew (Within-Bank)	Note 9		3	15	ps
	Bank-to-Bank Skew	Note 10		5	20	ps
	Part-to-Part Skew	Note 11			100	ps
t _{JITTER}	Data Random Jitter (RJ)	Note 12			1	ps _{RMS}
	Deterministic Jitter (DJ)	Note 13			10	ps _{PP}
	Clock Cycle-to-Cycle Jitter	Note 14			1	ps _{RMS}
		Note 15			10	ps _{PP}
	Crosstalk-Induced Jitter Channel-to-Channel	Note 16, Within-bank.			0.7	ps _{RMS}
t _r , t _f	Output Rise/Fall Time 20% to 80%	At full swing.	20	50	70	ps

Notes:

8. High-speed AC parameters are guaranteed by design and characterization. V_{IN} swing ≥ 100mV unless otherwise noted.
9. Input-to-input skew is the difference in time between two inputs to the output within a bank.
10. Bank-to-bank skew is the difference in time from input to the output between bank.
11. Part-to-part skew is defined for two parts with identical power supply voltages at the same temperature and with no skew of the edges at the respective inputs.
12. Random jitter is measured with a K28.7 comma detect character pattern, measured at 10.7Gbps and 2.5Gbps/3.2Gbps.
13. Deterministic jitter is measured at 2.5Gbps/3.2Gbps, with both K28.5 and 2²³-1 PRBS pattern
14. Cycle-to-cycle jitter definition: the variation of periods between adjacent cycles, T_n-T_{n-1} where T is the time between rising edges of the output signal.
15. Total jitter definition: with an ideal clock input of frequency - f_{MAX}, no more than one output edge in 10¹² output edges will deviate by more than the specified peak-to-peak jitter value.
16. Crosstalk is measured at the output while applying two similar frequencies that are asynchronous with respect to each other at the inputs.

TRUTH TABLES

INA0	/INA0	INA1	/INA1	SELA	QA	/QA
0	1	X	X	0	0	1
1	0	X	X	0	1	0
X	X	0	1	1	0	1
X	X	1	0	1	1	0

INB0	/INB0	INB1	/INB1	SELB	QB	/QB
0	1	X	X	0	0	1
1	0	X	X	0	1	0
X	X	0	1	1	0	1
X	X	1	0	1	1	0

SINGLE-ENDED AND DIFFERENTIAL SWINGS

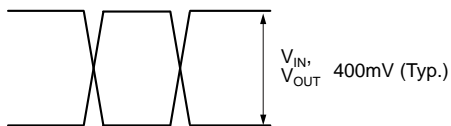

Figure 1a. Single-Ended Voltage Swing

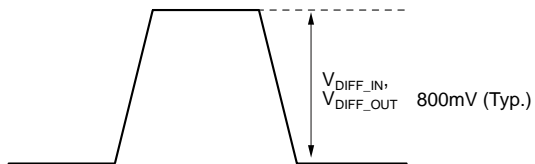
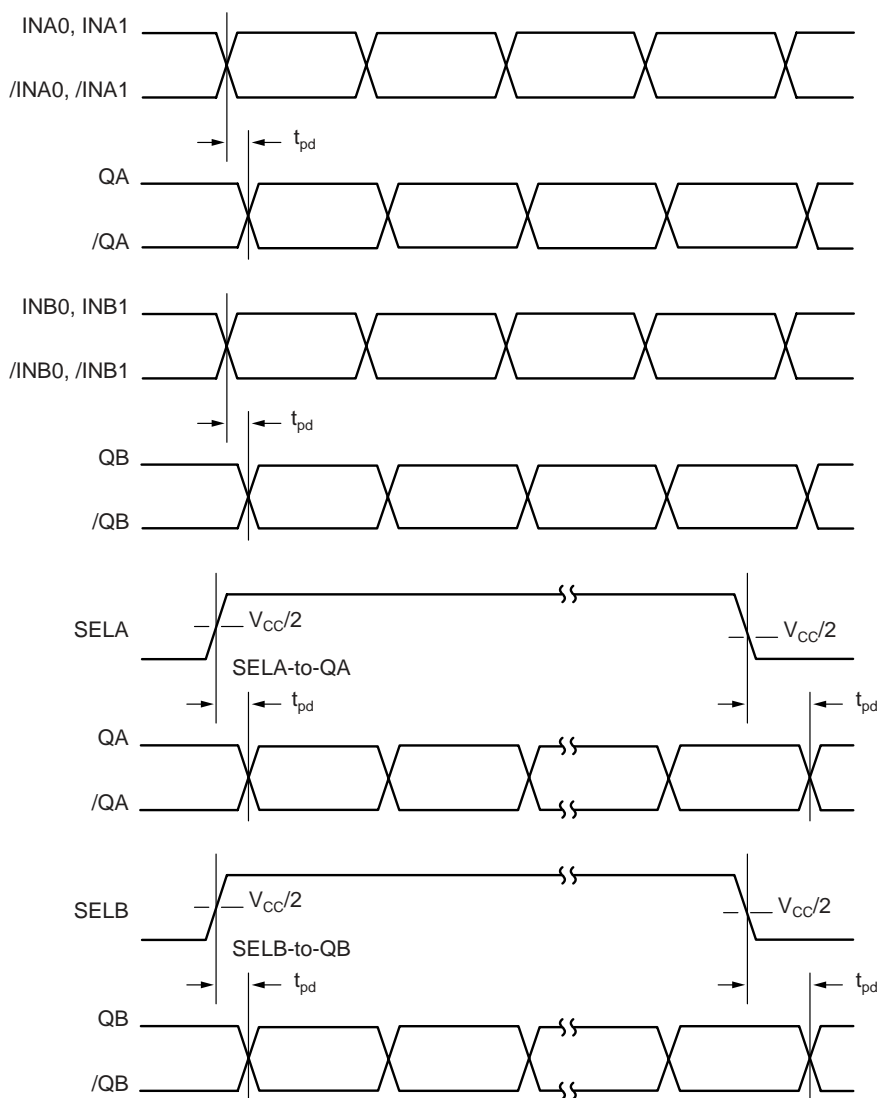

Figure 1b. Differential Voltage Swing

TIMING DIAGRAMS



TYPICAL OPERATING CHARACTERISTICS

$V_{CC} = 3.3V$, $T_A = 25^\circ C$, $R_L = 100\Omega$ across each pair, DC-coupled, unless otherwise stated.

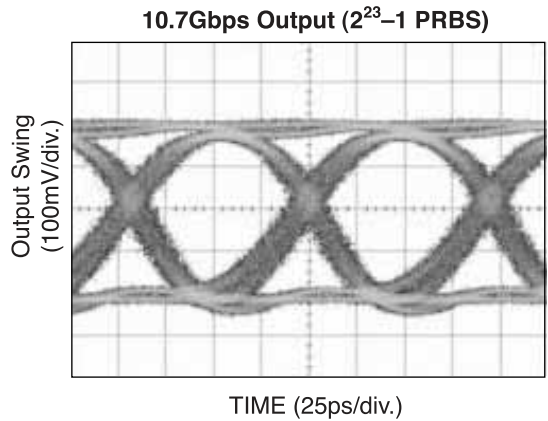
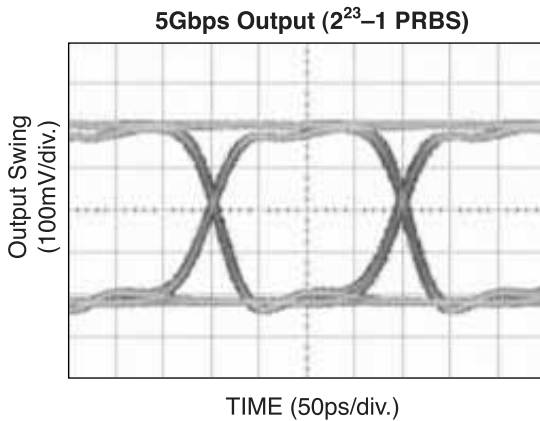
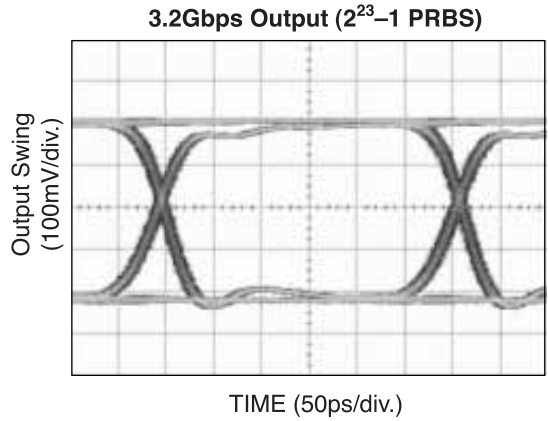
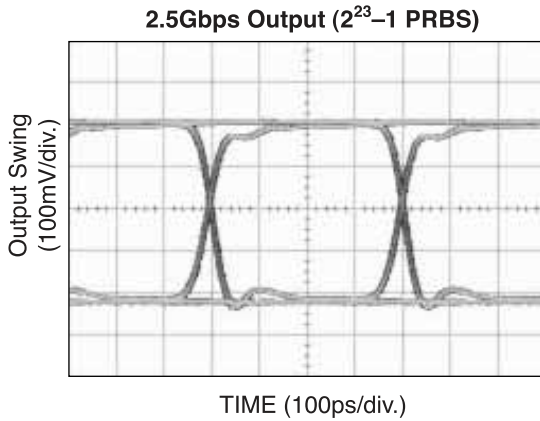
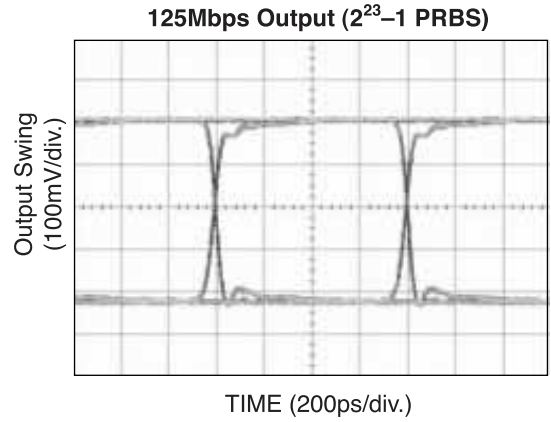
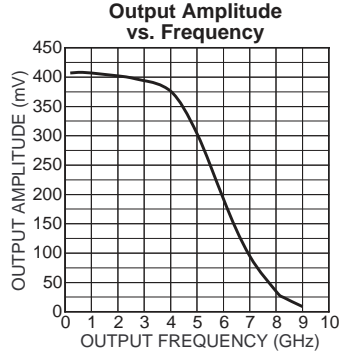
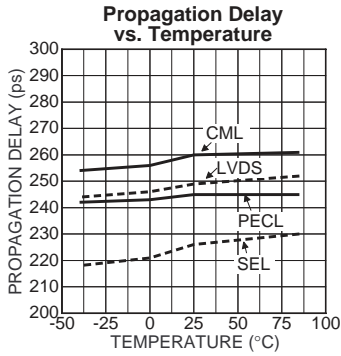

TYPICAL OPERATING CHARACTERISTICS

$V_{CC} = 3.3V$, $T_A = 25^\circ C$, $R_L = 100\Omega$ across each pair, DC-coupled, unless otherwise stated.

200MHz Clock

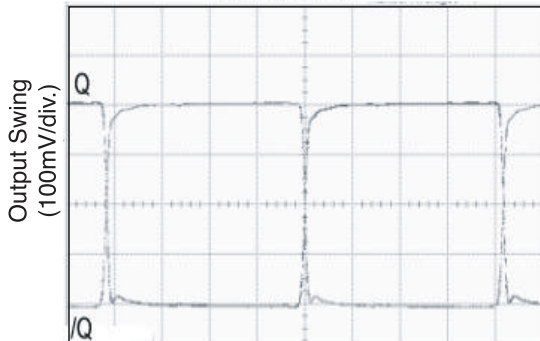

TIME (600ps/div.)

2GHz Clock

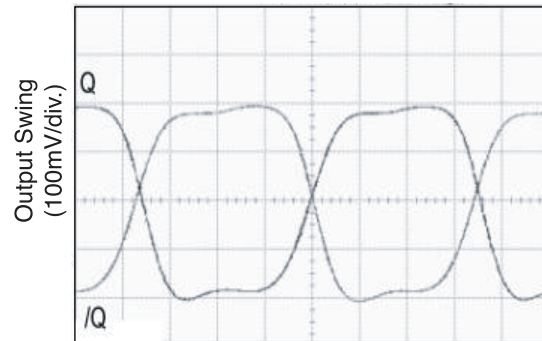

TIME (70ps/div.)

5GHz Clock

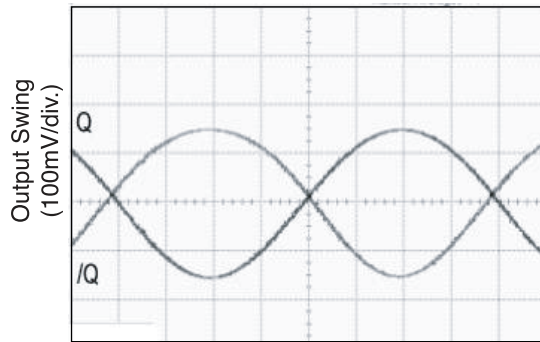

TIME (25ps/div.)

INPUT AND OUTPUT STAGE INTERNAL TERMINATION

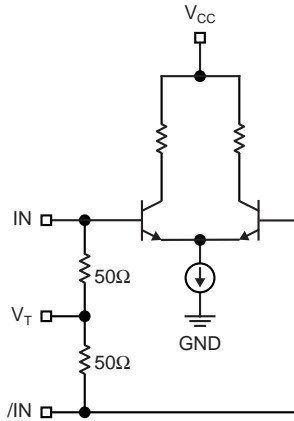

Figure 2a. Simplified Differential Input Stage

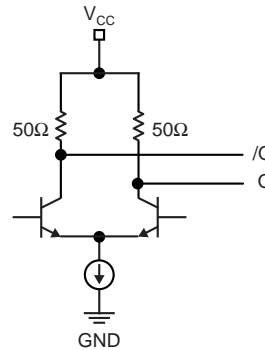
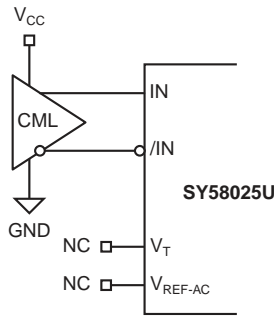

Figure 2b. Simplified CML Output Stage

INPUT INTERFACE APPLICATIONS



Option: may connect V_T to V_{CC}

Figure 3a. DC-Coupled CML Interface

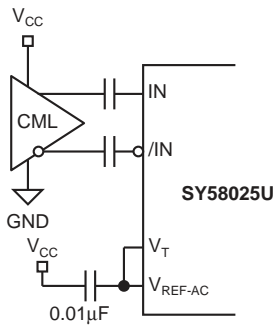
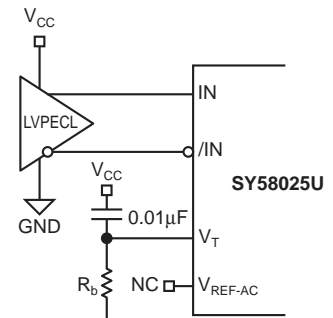
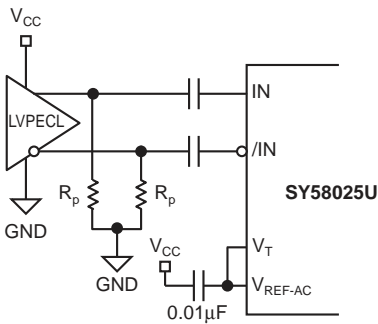

Figure 3b. AC-Coupled CML Interface



For V_{CC} = 3.3V, R_b = 50Ω.
For V_{CC} = 2.5V, R_b = 19Ω.

Figure 3c. DC-Coupled PECL Interface



For 3.3V, R_p = 100Ω.
For 2.5V, R_p = 50Ω.

Figure 3d. AC-Coupled PECL Interface

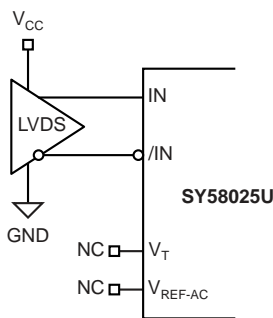

Figure 3e. LVDS Interface

OUTPUT INTERFACE APPLICATIONS

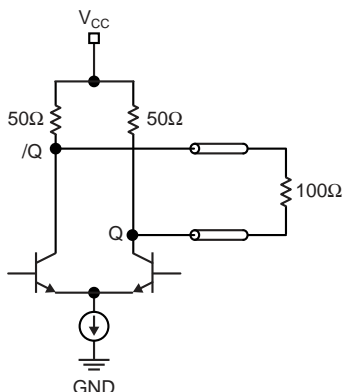

Figure 4. CML DC-Coupled Termination

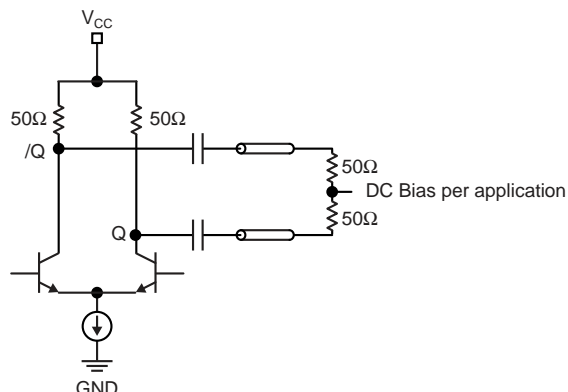
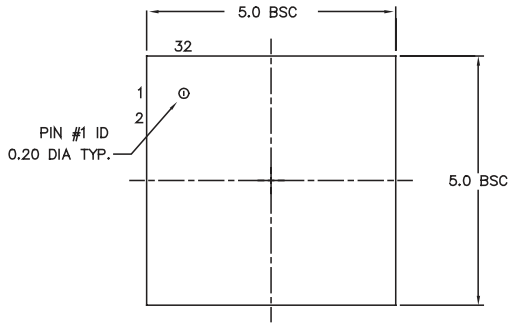

Figure 5. CML AC-Coupled Termination

RELATED MICREL PRODUCTS AND SUPPORT DOCUMENTATION

Part Number	Function	Data Sheet Link
SY58016L	3.3V 10Gbps Differential CML Line Driver/ Receiver with Internal Termination	http://www.micrel.com/product-info/products/sy58016l.shtml
SY58017U	10.7Gbps Differential CML 2:1 MUX with Internal Termination	http://www.micrel.com/product-info/products/sy58017u.shtml
SY58018U	5Gbps LVPECL 2:1 MUX with Internal Termination	http://www.micrel.com/product-info/products/sy58018u.shtml
SY58019U	10.7Gbps 400mV LVPECL 2:1 MUX with Internal Termination	http://www.micrel.com/product-info/products/sy58019u.shtml
SY58026U	5Gbps Dual 2:1 LVPECL MUX with Internal Termination	http://www.micrel.com/product-info/products/sy58026u.shtml
SY58027U	10.7Gbps Dual 2:1 400mV LVPECL MUX with Internal Termination	http://www.micrel.com/product-info/products/sy58027u.shtml
SY58051U	10.7Gbps AnyGate® with Internal Input and Output Termination	http://www.micrel.com/product-info/products/sy58051u.shtml
SY58052U	10Gbps Clock/Data Retimer with 50Ω Input Termination	http://www.micrel.com/product-info/products/sy58052u.shtml
	MLF™ Application Note	www.amkor.com/products/notes_papers/MLF_AppNote_0902.pdf
HBW Solutions	New Products and Applications	www.micrel.com/product-info/products/solutions.shtml

32-PIN MicroLeadFrame® (MLF-32)



TOP VIEW

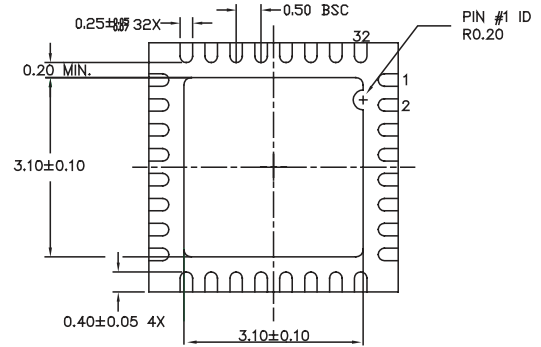

BOTTOM VIEW

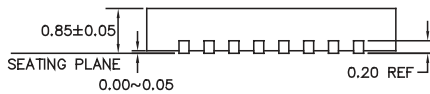

SIDE VIEW

NOTE:

1. ALL DIMENSIONS ARE IN MILLIMETERS.
2. MAX. PACKAGE WARPAGE IS 0.05 mm.
3. MAXIMUM ALLOWABLE BURRS IS 0.076 mm IN ALL DIRECTIONS.
4. PIN #1 ID ON TOP WILL BE LASER/INK MARKED.

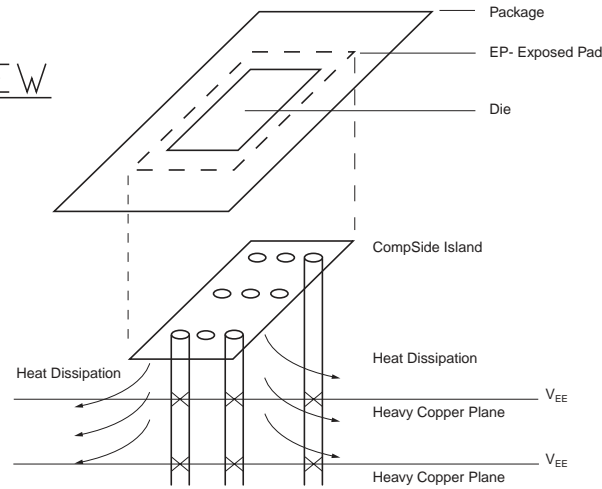

**PCB Thermal Consideration for 32-Pin MLF® Package
(Always solder, or equivalent, the exposed pad to the PCB)**

Package Notes:

1. Package meets Level 2 Moisture Sensitivity Classification.
2. All parts are dry-packaged before shipment.
3. Exposed pads must be soldered to a ground for proper thermal management.

MICREL, INC. 2180 FORTUNE DRIVE SAN JOSE, CA 95131 USA

TEL + 1 (408) 944-0800 FAX + 1 (408) 474-1000 WEB <http://www.micrel.com>

The information furnished by Micrel in this data sheet is believed to be accurate and reliable. However, no responsibility is assumed by Micrel for its use. Micrel reserves the right to change circuitry and specifications at any time without notification to the customer.

Micrel Products are not designed or authorized for use as components in life support appliances, devices or systems where malfunction of a product can reasonably be expected to result in personal injury. Life support devices or systems are devices or systems that (a) are intended for surgical implant into the body or (b) support or sustain life, and whose failure to perform can be reasonably expected to result in a significant injury to the user. A Purchaser's use or sale of Micrel Products for use in life support appliances, devices or systems is at Purchaser's own risk and Purchaser agrees to fully indemnify Micrel for any damages resulting from such use or sale.