

ROM-5420

NXP ARM® Cortex®-A9 i.MX6 SMARC v1.1 Module

NEW



Features

- NXP ARM® Cortex® -A9 i.MX6 high performance processor
- Onboard DDR3 memory and eMMC 4GB
- Parallel RGB, HDMI, single channel 18/24-bit LVDS, 1366 x 768
- 2 x CAN, 4 x UART, 5 x I²C, 12 x GPIO, 1 x PCIe, 1 x camera input and 1 x Gigabit LAN
- Supports OpenGL ES 2.0 and OpenVG 1.1 hardware accelerators
- Supports full HD hardware encode/decode engine
- Low power consumption, fanless design
- Supports Linux and Android BSP



Introduction

ROM-5420 B1 compatible with SMARC v1.1 specification and has integrated NXP i.MX6 Cortex-A9 SoC. The i.MX6 supports powerful CPU performance and 2D/3D graphics accelerators. ROM-5420 B1 series supports rich interfaces such as camera, CAN, UART, I²C, GPIO and it is specially designed for portable applications.

ROM-5420 B1 also offered the optimized OS BSP, images, test utilities, schematic check tool and carrier board design guide for customer for their application development and device integration.



Specifications

Form Factor		SMARC v1.1
Processor System	CPU	NXP ARM Cortex-A9 i.MX6 800MHz/1GHz
Memory	Technology	DDR3 1066 MHz up to 2GB
	Capacity	On-board DDR3
	Flash	4 GB eMMC NAND Flash for O.S. and 4 MB SPI NOR Flash for Advantech boot loader
Graphics	LVDS	1 Single 24-bit LVDS, 1366 x 768 at 60Hz
	HDMI	1920 x 1080 at 60Hz
	Parallel RGB	1 24-bit TTL, 1920 x 1200 at 60Hz
	VGA	-
	Graphics Engine	2 IPUs. OpenGL ES 2.0 for 3D, BitBlit for 2D and OpenVG 1.1
	H/W Video Codec	Decoder: MPEG-4 ASP, H.264 HP, H.263, MPEG-2 MP, MJPEG BP Encoder: MPEG-4 SP, H.264 BP, H.263, MJPEG BP
Ethernet	Chipset	NXP i.MX6 integrated RGMII
	Speed	1 x 10/100/1000 Mbps
RTC	RTC	Yes
WatchDog Timer		256-level timer interval, from 0 ~ 128 sec
I/O	PCIe	1 PCIe x 1
	SATA	1 SATA II
	USB	1 USB 2.0, 1 USB 2.0 OTG
	Audio	I ² S
	SPDIF	1
	SDIO	1
	Serial Port	4 UART (2 x 2 wire, 2 x 4 wire w/ 3.3V)
	SPI	4
	CAN	2 x CAN bus 2.0B
	GPIO	12
	I ² C	5
	Camera Input	1 MIPI v1.0, 4x Lane
	System Bus	-
	Touch	-
Keypad	-	
Power	Power Supply Voltage	+3 ~ 5.25 V
	Power Consumption	3.1W (Max)
Environment	Operating Temperature	0 ~ 60 °C/ -40 ~ 85 °C
	Operating Humidity	0% ~ 90% relative humidity, non-condensing
Mechanical	Dimensions (W x D)	82 x 50 mm
Operation System		Linux & Android
Certifications		CE/FCC Class B

Block Diagram

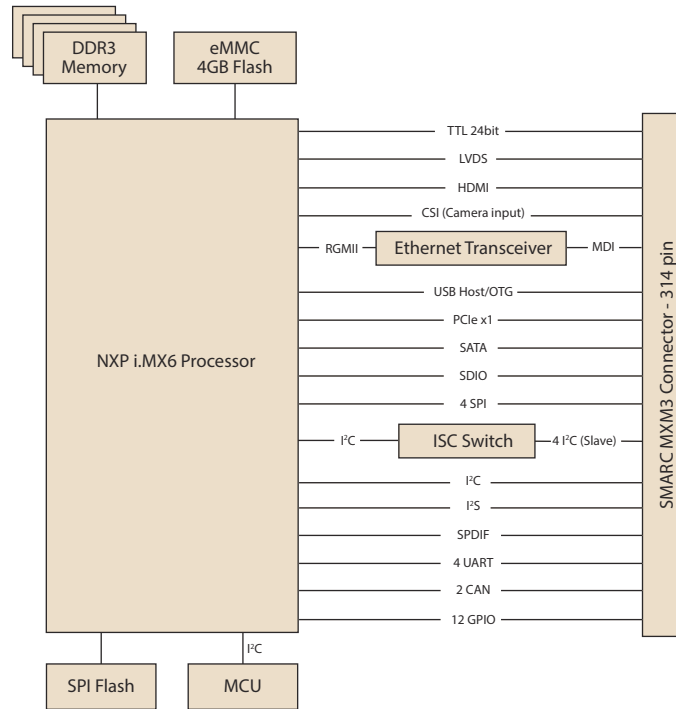

Ordering Information

Part No.	CPU	Memory	Flash Memory	UART	LAN	USB Host	USB OTG	Display	SATA	PCIe	HDMI	SD	CANbus	I ² C	SPI	Size	Power input	Operating Temperature
ROM-5420CD-MDB1E	i.mx6 Dual 1GHz	1GB	4 GB	4	1	1	1	1x 24bit LVDS 1x 24bit TTL 1x HDMI	1	1	1	1	2	5	4	82 x 50 x 5 mm	3 ~ 5.25V	0 ~ 60 °C
ROM-5420CD-MEB1E	i.mx6 Dual 1GHz	2GB	4 GB	4	1	1	1	1x 24bit LVDS 1x 24bit TTL 1x HDMI	1	1	1	1	2	5	4	82 x 50 x 5 mm	3 ~ 5.25V	0 ~ 60 °C
ROM-5420CQ-MEB1E	i.mx6 Quad 1GHz	2GB	4 GB	4	1	1	1	1x 24bit LVDS 1x 24bit TTL 1x HDMI	1	1	1	1	2	5	4	82 x 50 x 5 mm	3 ~ 5.25V	0 ~ 60 °C
ROM-5420WQ-MEB1E	i.mx6 Quad 800MHz	2GB	4 GB	4	1	1	1	1x 24bit LVDS 1x 24bit TTL 1x HDMI	1	1	1	1	2	5	4	82 x 50 x 5 mm	3 ~ 5.25V	-40 ~ 85 °C

Development Board

Part No.	Description
ROM-DB5900-SWA2E	Development Board for SMARC v1.1

Optional Accessories

Part No.	Description
1700022373-01	Debug port cable for ROM-3420/5420
9696ED2000E	Debug adapter board
1960075867N001	Heat spreader
1930005215	Screws for heat spreader
1960063089N001	Semi heat sink
1930004835	Screws for heat spreader and semi heat sink

Dimensions

Unit: mm

