

Application Example for Capacitive Touch (AE-CAP1)

User's Manual

Renesas Synergy™ Platform
Synergy Solutions
Kits: AE-CAP1 v1.1

All information contained in these materials, including products and product specifications, represents information on the product at the time of publication and is subject to change by Renesas Electronics Corp. without notice. Please review the latest information published by Renesas Electronics Corp. through various means, including the Renesas Electronics Corp. website (<http://www.renesas.com>).

Notice

1. Descriptions of circuits, software and other related information in this document are provided only to illustrate the operation of semiconductor products and application examples. You are fully responsible for the incorporation or any other use of the circuits, software, and information in the design of your product or system. Renesas Electronics disclaims any and all liability for any losses and damages incurred by you or third parties arising from the use of these circuits, software, or information.
2. Renesas Electronics hereby expressly disclaims any warranties against and liability for infringement or any other disputes involving patents, copyrights, or other intellectual property rights of third parties, by or arising from the use of Renesas Electronics products or technical information described in this document, including but not limited to, the product data, drawing, chart, program, algorithm, application examples.
3. No license, express, implied or otherwise, is granted hereby under any patents, copyrights or other intellectual property rights of Renesas Electronics or others.
4. You shall not alter, modify, copy, or otherwise misappropriate any Renesas Electronics product, whether in whole or in part. Renesas Electronics disclaims any and all liability for any losses or damages incurred by you or third parties arising from such alteration, modification, copy or otherwise misappropriation of Renesas Electronics products.
5. Renesas Electronics products are classified according to the following two quality grades: "Standard" and "High Quality". The intended applications for each Renesas Electronics product depends on the product's quality grade, as indicated below.
"Standard": Computers; office equipment; communications equipment; test and measurement equipment; audio and visual equipment; home electronic appliances; machine tools; personal electronic equipment; and industrial robots etc.
"High Quality": Transportation equipment (automobiles, trains, ships, etc.); traffic control (traffic lights); large-scale communication equipment; key financial terminal systems; safety control equipment; etc.

Renesas Electronics products are neither intended nor authorized for use in products or systems that may pose a direct threat to human life or bodily injury (artificial life support devices or systems, surgical implantations etc.), or may cause serious property damages (space and undersea repeaters; nuclear power control systems; aircraft control systems; key plant systems; military equipment; etc.). Renesas Electronics disclaims any and all liability for any damages or losses incurred by you or third parties arising from the use of any Renesas Electronics product for which the product is not intended by Renesas Electronics.

6. When using the Renesas Electronics products, refer to the latest product information (data sheets, user's manuals, application notes, "General Notes for Handling and Using Semiconductor Devices" in the reliability handbook, etc.), and ensure that usage conditions are within the ranges specified by Renesas Electronics with respect to maximum ratings, operating power supply voltage range, heat radiation characteristics, installation, etc. Renesas Electronics disclaims any and all liability for any malfunctions or failure or accident arising out of the use of Renesas Electronics products beyond such specified ranges.
7. Although Renesas Electronics endeavors to improve the quality and reliability of Renesas Electronics products, semiconductor products have specific characteristics such as the occurrence of failure at a certain rate and malfunctions under certain use conditions. Further, Renesas Electronics products are not subject to radiation resistance design. Please ensure to implement safety measures to guard them against the possibility of bodily injury, injury or damage caused by fire, and social damage in the event of failure or malfunction of Renesas Electronics products, such as safety design for hardware and software including but not limited to redundancy, fire control and malfunction prevention, appropriate treatment for aging degradation or any other appropriate measures by your own responsibility as warranty for your products/system. Because the evaluation of microcomputer software alone is very difficult and not practical, please evaluate the safety of the final products or systems manufactured by you.
8. Please contact a Renesas Electronics sales office for details as to environmental matters such as the environmental compatibility of each Renesas Electronics product. Please investigate applicable laws and regulations that regulate the inclusion or use of controlled substances, including without limitation, the EU RoHS Directive carefully and sufficiently and use Renesas Electronics products in compliance with all these applicable laws and regulations. Renesas Electronics disclaims any and all liability for damages or losses occurring as a result of your noncompliance with applicable laws and regulations.
9. Renesas Electronics products and technologies shall not be used for or incorporated into any products or systems whose manufacture, use, or sale is prohibited under any applicable domestic or foreign laws or regulations. You shall not use Renesas Electronics products or technologies for (1) any purpose relating to the development, design, manufacture, use, stockpiling, etc., of weapons of mass destruction, such as nuclear weapons, chemical weapons, or biological weapons, or missiles (including unmanned aerial vehicles (UAVs)) for delivering such weapons, (2) any purpose relating to the development, design, manufacture, or use of conventional weapons, or (3) any other purpose of disturbing international peace and security, and you shall not sell, export, lease, transfer, or release Renesas Electronics products or technologies to any third party whether directly or indirectly with knowledge or reason to know that the third party or any other party will engage in the activities described above. When exporting, selling, transferring, etc., Renesas Electronics products or technologies, you shall comply with any applicable export control laws and regulations promulgated and administered by the governments of the countries asserting jurisdiction over the parties or transactions.
10. Please acknowledge and agree that you shall bear all the losses and damages which are incurred from the misuse or violation of the terms and conditions described in this document, including this notice, and hold Renesas Electronics harmless, if such misuse or violation results from your resale or making Renesas Electronics products available any third party.
11. This document shall not be reprinted, reproduced or duplicated in any form, in whole or in part, without prior written consent of Renesas Electronics.
12. Please contact a Renesas Electronics sales office if you have any questions regarding the information contained in this document or Renesas Electronics products.

(Note 1) "Renesas Electronics" as used in this document means Renesas Electronics Corporation and also includes its majority-owned subsidiaries.

(Note 2) "Renesas Electronics product(s)" means any product developed or manufactured by or for Renesas Electronics.

Renesas Synergy™ Application Example for Capacitive Touch (AE-CAP1) Disclaimer

By using this AE-CAP1 kit, the user accepts the following terms, which are in addition to, and control in the event of disagreement, with Renesas' General Terms and Conditions available at <https://www.renesas.com/en-us/legal/disclaimer.html>.

The AE-CAP1 is not guaranteed to be error free, and the entire risk as to the results and performance of the AE-CAP1 is assumed by the User. The AE-CAP1 is provided by Renesas on an "as is" basis without warranty of any kind whether express or implied, including but not limited to the implied warranties of satisfactory quality, fitness for a particular purpose, title, and non-infringement of intellectual property rights with regard to the AE-CAP1. Renesas expressly disclaims all such warranties.

Renesas does not consider the AE-CAP1 a finished product and therefore the AE-CAP1 may not yet comply with some requirements applicable to finished products, including, but not limited to recycling (WEEE), CE, UL, restricted substances (ROHS), FCC, FEE, and electromagnetic compatibility regulations. Renesas or its affiliates shall in no event be liable for any loss of profit, loss of data, loss of contract, loss of business, damage to reputation or goodwill, any economic loss, any reprogramming or recall costs (whether the foregoing losses are direct or indirect) nor shall Renesas or its affiliates be liable for any other direct or indirect special, incidental or consequential damages arising out of or in relation to the use of this AE-CAP1, even if Renesas or its affiliates have been advised of the possibility of such damages.

Renesas has used reasonable care in preparing the information included in this document, but Renesas does not warrant that such information is error free nor does Renesas guarantee an exact match for every application or parameter to part numbers designated by other vendors listed herein. The information provided in this document is intended solely to enable the use of Renesas products. No express or implied license to any intellectual property right is granted by this document or in connection with the sale of Renesas products. Renesas reserves the right to make changes to specifications and product descriptions at any time without notice. Renesas assumes no liability for any damages incurred by you resulting from errors in or omissions from the information included herein. Renesas cannot verify, and assumes no liability for, the accuracy of information available on another company's website.

Precautions

This Renesas Synergy™ Application Example for Capacitive Touch (AE-CAP1) is intended only for use in a laboratory environment under ambient temperature and humidity conditions. A safe separation distance should be used between this and any sensitive equipment. Its use outside the laboratory, classroom, study area, or similar such area invalidates conformity with the protection requirements of the Electromagnetic Compatibility Directive and could lead to prosecution.

The product generates, uses, and can radiate radio frequency energy and may cause harmful interference to radio communications. - There is no guarantee that interference will not occur in a particular installation. If this equipment causes harmful interference to radio or television reception, which can be determined by turning the equipment off or on, you are encouraged to try to correct the interference by one or more of the following measures:

- Ensure attached cables do not lie across the equipment.
- Reorient the receiving antenna.
- Increase the distance between the equipment and the receiver.
- Connect the equipment into an outlet on a circuit different from that which the receiver is connected.
- Power down the equipment when not in use.
- Consult the dealer or an experienced radio/TV technician for help.

Note: It is recommended that wherever possible shielded interface cables are used.

The product is potentially susceptible to certain EMC phenomena. To mitigate against them it is recommended that the following measures be undertaken:

- The user is advised that mobile phones should not be used within 10 m of the product when in use.
- The user is advised to take ESD precautions when handling the equipment.

The Renesas Synergy™ AE-CAP1 Application Example for Capacitive Touch does not represent an ideal reference design for an end product and does not fulfill the regulatory standards for an end product.

Contents

1. Overview	5
1.1 Purpose.....	5
1.4 ESD precautions.....	9
1.5 Physical characteristics	9
1.6 Hardware features	9
1.6.1 AE-CAP1-S1 Target Board.....	9
2. Getting Started	13
2.1 Powering the AE-CAP1	13
2.2 Tools installation overview	14
2.3 See the demo	14
2.4 On-board Debugger	14
3. Board Layout	15
3.1 Component placement.....	15
3.2 Overlay layout.....	25
4. Block Diagrams	26
4.1 Block diagram, S1 Target Board.....	26
4.2 Block diagram, S3 Target Board.....	27
4.3 Touch application board variations.....	27
4.3.1 AE-CAP1-BWS	27
4.3.2 AE-CAP1-MC.....	28
4.3.3 AE-CAP1-SC	28
5. Circuitry	29
5.1 Power Supply	29
5.2 Power-up behavior	29
5.3 +5-V source selection	29
5.4 3.3-V main power subsystem.....	29
5.5 AE-CAP1-S1 programming jumper.....	29
5.6 LEDs	30
5.6.1 Target board LEDs.....	30
5.6.2 AE-CAP1-BWS LEDs	30
5.6.3 AE-CAP1-MC LEDs.....	32
5.7 Switches	32
5.7.1 Target board switches.....	32
5.7.2 Application board switches	33
5.8 Button to MCU sense map	36
5.9 Target to app board connectors	37
5.9.1 Connector A	37
5.9.2 Connector B	38
5.10 USB device	39
5.11 J-Link OB USB.....	39
5.12 USB cables.....	40
5.13 External power supply	40
5.14 Port numbering.....	40
6. Glossary	41
6.1 Abbreviations and acronyms.....	41

1. Overview

1.1 Purpose

This manual provides the user with an understanding of the hardware functionality and electrical characteristics. It is intended for users designing sample code on the platform, using the many different incorporated peripheral devices.

The manual comprises an overview of the capabilities of the product, but does not intend to be a guide to embedded programming or hardware design. Details on setting up the MCU and development environment can found in the relevant user's manuals for those tools/products. Make sure to refer to the latest versions of these documents. The newest versions of the documents listed may be obtained from the Renesas Electronics web site.

The AE-CAP1 is primarily intended for software and hardware developers to develop firmware, conduct experiments, and evaluate the extensive I/O features of the Synergy S124 and S3A7 MCUs prior to development of their own customized hardware.

The Target Board showcases the Renesas Synergy™ S124 microcontroller in an LQFP64 package. The Target Board includes UART, I²C, USB Device communications ports, two programmable push buttons, and two programmable LEDs. AE-CAP1 included Application Boards demonstrate touch wheels, touch buttons, touch slider, LEDs for visual feedback and status, and design techniques for mutual and self-capacitance sensors. Test points are located on the board for MCU power monitoring, and a jumper is provided for selection of USB or barrel connector power.

The Target Board showcases the Renesas Synergy™ S3A7 microcontroller in an LQFP144 package. The Target Board includes UART, I²C, USB Device communications ports, three programmable push buttons, and three programmable LEDs. AE-CAP1 included Application Boards demonstrate touch wheels, touch buttons, touch slider, LEDs for visual feedback and status, and design techniques for mutual and self-capacitance sensors. Test points are located on the board for MCU power monitoring, and a jumper is provided for selection of USB or barrel connector power.

The AE-CAP1 is supported by the e² studio ISDE from Renesas and the IAR Embedded Workbench® for Renesas Synergy™ (IAR EW for Synergy).

For more information on the Synergy AE-CAP1, visit the Synergy website at <http://renessasynergy.com>.

1.2 Kit contents

Upon receiving your AE-CAP1 kit you will find several items in the box. The Quick Start Guide provides a quick method for unboxing and getting the pre-programmed demonstration firmware on the AE-CAP1 Target Boards running. Using this document, the user can also find information to set up the necessary tools to further explore the AE-CAP1 kit features.

Included items:

- AE-CAP1 Quick Start Guide (QSG)
- AE-CAP1-S1 Target Board with header connectors for attachment of capacitive touch application boards, including a J-Link Emulator/Debugger installed on-board (Figure 1)
- AE-CAP1-S3 Target Board with header connectors for attachment of capacitive touch application boards, including a J-Link Emulator/Debugger installed on-board (Figure 2)
- AE-CAP1-BWS Application Board with installed overlay for the touch-buttons, touch-wheel, and touch-slider (Figure 3)
- AE-CAP1-MC Application Board with installed overlay for the mutual-capacitance touch-buttons (Figure 4)
- AE-CAP1-SC Application Board with installed overlay for the self-capacitance touch-buttons (Figure 5)
- Two 3-foot USB cables: Type-A connector to Micro-B connector

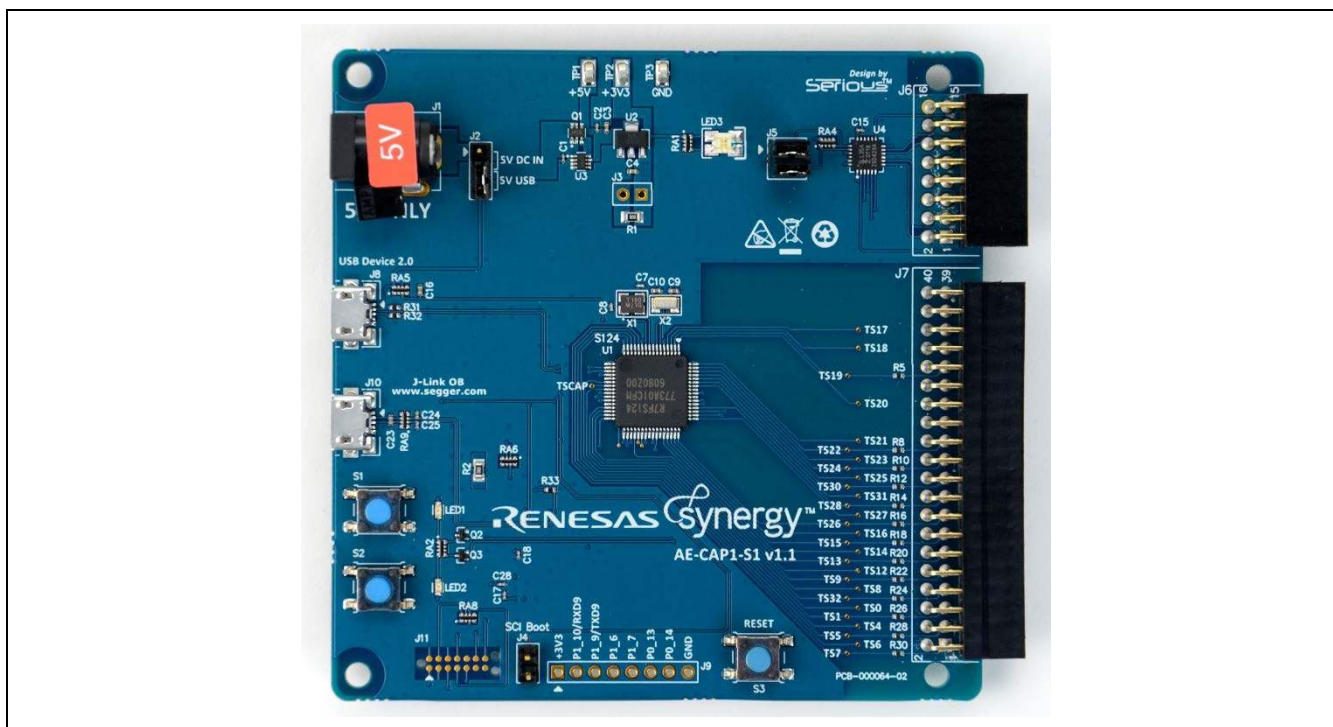

Figure 1 AE-CAP1-S1 Target Board

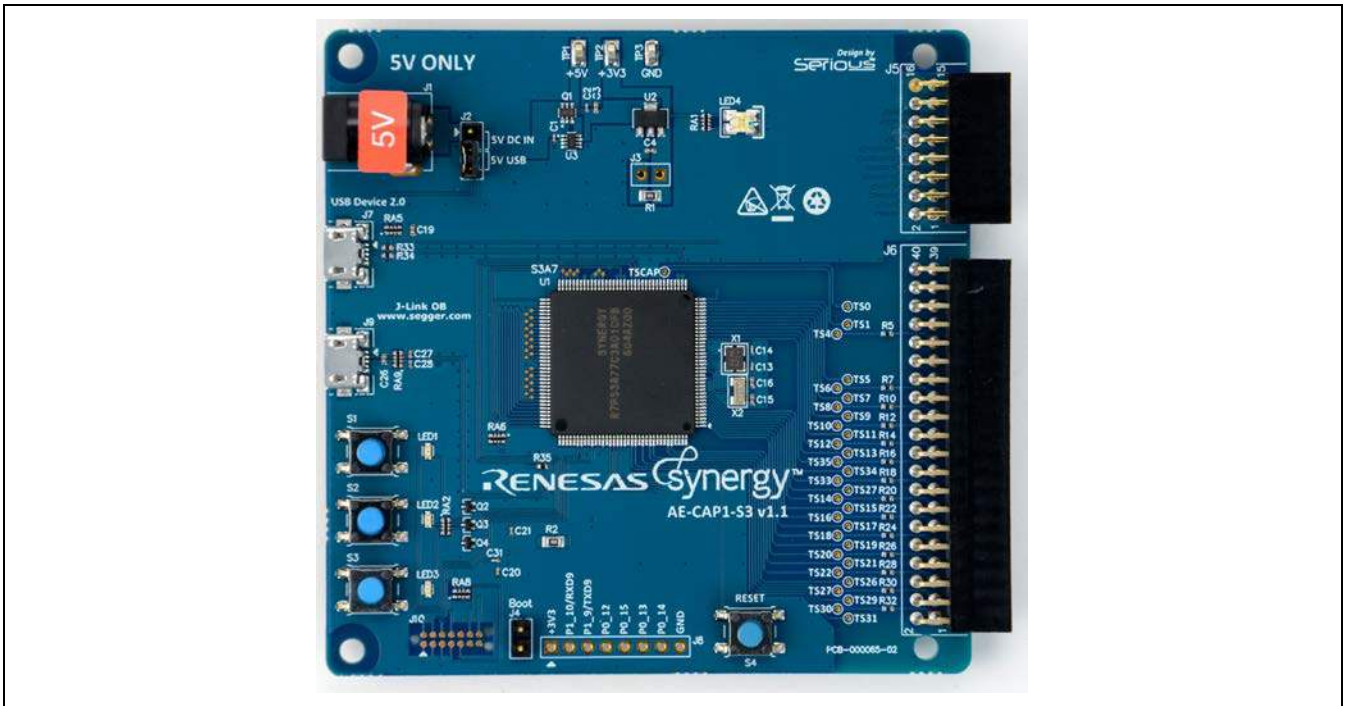

Figure 2 AE-CAP1-S3 Target Board



Figure 3 AE-CAP1-BWS Application Board

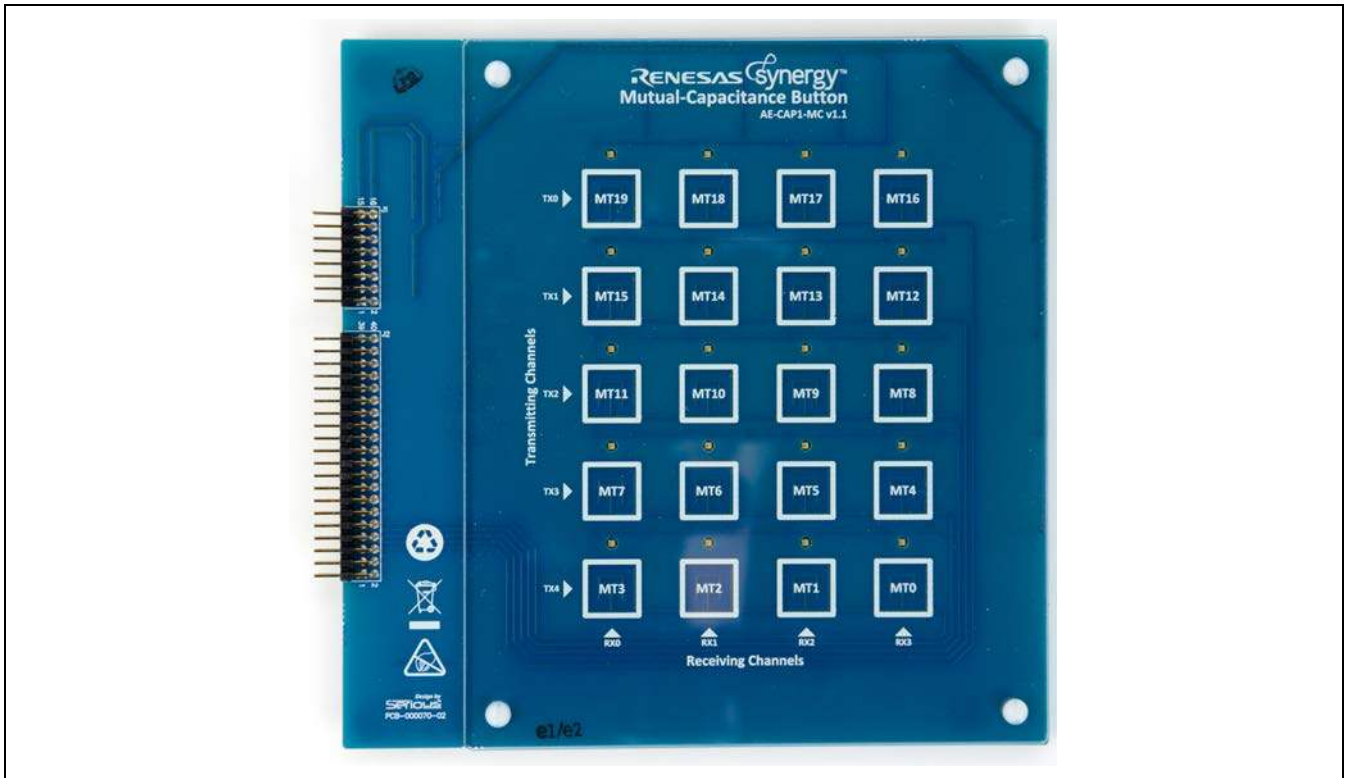

Figure 4 AE-CAP1-MC Application Board

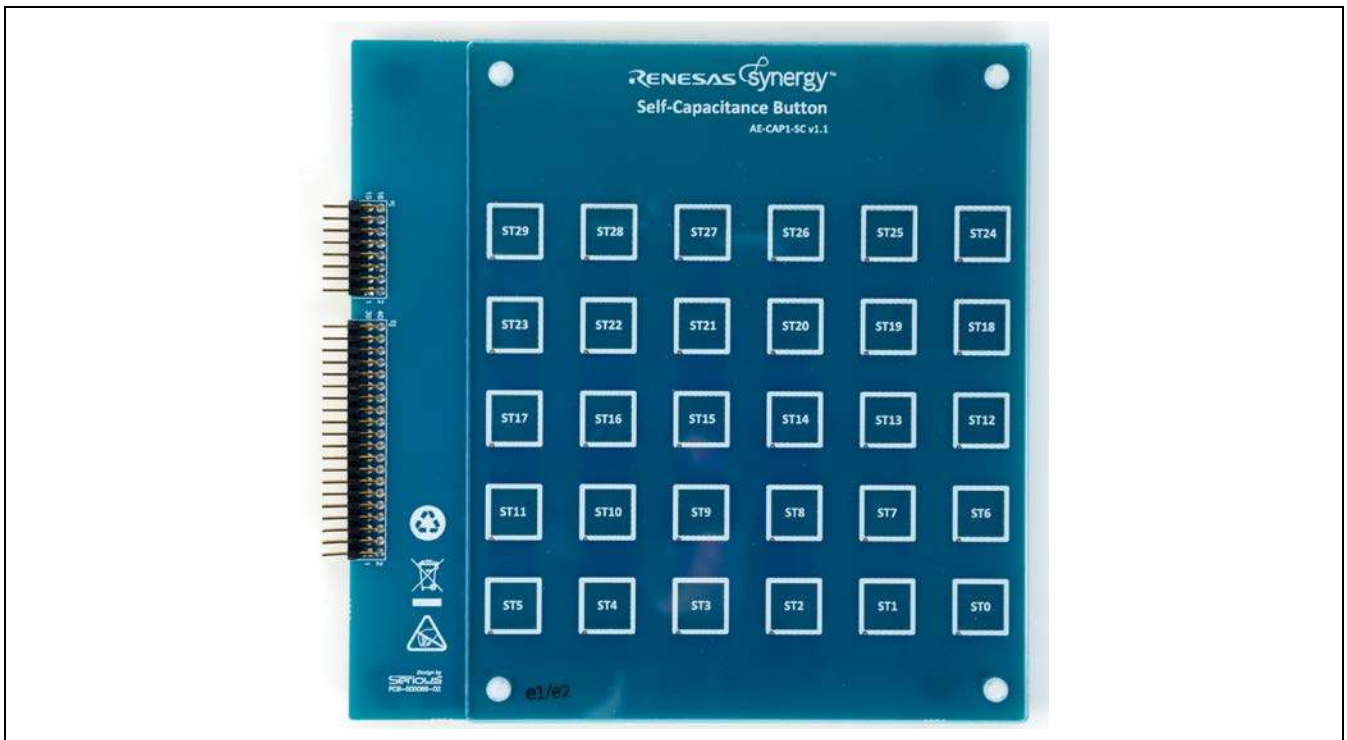

Figure 5 AE-CAP1-SC Application Board

1.3 Environmental characteristics

The AE-CAP1, while designed with production-worthy methods and components, is not designed as a production unit to be used in OEM equipment. Contact Renesas for a list of hardware design partners who can develop and deliver production-ready platforms based on the components used in the AE-CAP1.

Table 1 Environmental Temperature and Humidity Limits

Specification	Permissible			
	Minimum	Typical	Maximum	Unit
Storage Temperature	-40	25	85	°C
Operating Temperature	-40	25	85	°C
Humidity (Non-condensing)	5%		95%	RH

1.4 ESD precautions

The AE-CAP1 development kit provides a Synergy Capacitive Touch application example. This product is not meant to be deployed directly to the field. The user should always use proper ESD precautions when handling product components. General ESD handling guidelines include operating in an electrostatic protected area (EPA) while wearing a grounded wrist band. Always transport and store the kit in anti-static/conductive containers.

If ESD is introduced that results in disruption of normal operation, completely remove power to the board. Allow time for power supply capacitors to discharge before re-applying power and re-starting operations.

1.5 Physical characteristics

The outer dimensions of the AE-CAP1-S1 Target Board are approximately 89 x 89 x 14.9 mm.

The outer dimensions of the AE-CAP1-S3 Target Board are approximately 89 x 89 x 14.9 mm.

The outer dimensions of the AE-CAP1-BWS, AE-CAP1-MC, and AE-CAP1-SC application boards are each approximately 145 x 145 x 12 mm including the overlay, fasteners, and connectors. Pins of the two connectors protrude about 6.0 mm outward from the left side of the board.

1.6 Hardware features

1.6.1 AE-CAP1-S1 Target Board

1.6.1.1 MCU and board memory

- Synergy S1 MCU
 - 32-MHz ARM Cortex™-M0+ core
 - 16-KB on-chip SRAM
 - 64- or 128-KB on-chip code flash memory
 - 4-KB on-chip data flash memory
 - For additional peripherals, features, and configurations availability, refer to *S124 User's Manual: Microcontrollers*
- 32.768-kHz RTC crystal and 16-MHz MCU clock crystal
- MCU reset push-button switch

1.6.1.2 Power

- Main power input of 5 V to barrel jack J1, or J8 USB Device input of 5 V
- 5-V to 3.3-V system power regulator
- Jumper-configurable header allowing selection of power source, and header providing pins for MCU current monitoring

1.6.1.3 I/O features

- Touch APP board connector A, providing touch sense signal interfaces
- Touch APP board connector B, providing touch board LED control, including an I²C port expander to increase effective pin count of the MCU
- Configurable UART/I²C, digital I/O, ADC input, and DAC output connector
- Full-Speed (FS) USB 2.0 Device port (micro-B)
- Two user configurable LEDs (red and yellow)
- Two user configurable momentary button switches
- Status indicator LED, green for power availability, red for J-Link status

1.6.1.4 Programming and debug features

- J-Link USB Micro-B connection provided with separate supporting microcontroller to allow SWD programming and debug of the S124 microcontroller using a USB interface and the SEGGER J-Link software.
- Separate Tag-Connect interface pin-pattern provided for programming the J-Link microcontroller, if needed

1.6.2 AE-CAP1-S3 Target Board

1.6.2.1 MCU and board memory

- Synergy S3 MCU
 - 48MHz ARM Cortex™-M4 core
 - 192 KB on-chip SRAM
 - 1 MB on-chip code flash memory
 - 16 KB on-chip data flash memory
 - For additional peripherals, features, and configurations availability, refer to *S3A7 User's Manual: Microcontrollers*
- 32.768kHz RTCC crystal and 12MHz MCU clock crystal
- MCU reset push-button switch

1.6.2.2 Power

- Main power input of 5V to barrel jack J1, or J7 USB Device input of 5V
- 5V to 3.3V system power regulator
- Jumper-configurable header allowing selection of power source, and header providing pins for MCU current monitoring.

1.6.2.3 I/O features

- Touch APP board connector A, providing touch sense signal interfaces
- Touch APP board connector B, providing touch board LED control
- Configurable UART/I²C, digital I/O, ADC input, and DAC output connector
- Full-Speed USB 2.0 Device port (micro-B)
- Three user configurable LEDs (red, yellow, and green)
- Three user configurable momentary button switches
- Status indicator LED, green for power availability, red for J-Link status

1.6.2.4 Programming and debug features

- J-Link USB Micro-B connection provided with separate supporting microcontroller to allow SWD programming and debug of the S3A7 microcontroller using a USB interface
- Separate Tag-Connect interface pin-pattern provided for programming the J-Link microcontroller, if needed

1.6.3 AE-CAP1-BWS self-capacitance BWS application board

- Button-Wheel-Slider demonstration board with LEDs to indicate status of touch recognition
- Connected to the Target Board by two right-angle pin headers, totaling 56 pins
- Provides all support circuitry to matrix select and drive 25 indicator LEDs using a 7 column pull-up by 4 row pull-down drive configuration
- Provides an analog identification signal at 5/8 of the LED power voltage supplied by the Target Board
- Provides patterns and support connections for driving a total of 20 self-capacitance touch sense regions arranged as
 - One Wheel pattern having an 8 sense region outer ring, a 4 sense region inner ring and a center round sense button
 - One Slider pattern having 5 sense regions
 - Two square button sense regions
- Includes a plastic overlay for the touch-regions of the circuit to control touch capacitance and mitigate possible ESD damage to circuitry from touch events

1.6.4 AE-CAP1-MC mutual-capacitance application board

- Pattern-of-Buttons board demonstrating mutual-capacitance sensing technology
- Connected to the Target Board by two right-angle pin headers, totaling 56 pins
- Provides all support circuitry to matrix select and drive 20 indicator LEDs
 - Is arranged as a four-column pull-up by five-row pull-down drive configuration for the matrix multiplication of the LED count versus the available microcontroller logical control channel count. For example, with this board approach and the AE-CAP-S3 Target Board's available 13 logical control channels on Connector B, an Application Board with up to 42 controlled LEDs could be designed.
 - An LED is located immediately above each of the touch buttons
- Provides an analog identification signal at 3/8 of the LED power voltage supplied by the Target Board
- Provides patterns and support connections for driving a total of 20 mutual-capacitance touch sense regions
 - Is arranged as 5 rows by 4 columns of square touch buttons in a square array
 - Logically configured as 5 transmitting signal channel columns by 4 receiving channel rows for matrix multiplication of button count versus available microcontroller touch-sense channel count. For example with this board approach and the AE-CAP-S3 Target Board's available 30 touch-sense channels on Connector A, an Application Board with up to 225 (15 x 15) touch-sense regions could be designed.
- Includes a plastic overlay for the touch-regions of the circuit to control touch capacitance and mitigate possible ESD damage to circuitry from touch events

1.6.5 AE-CAP1-SC self-capacitance application board

- Pattern-of-Buttons board demonstrating self-capacitance sensing technology
- Connected to the Target Board by two right-angle pin headers, totaling 56 pins
- Includes no LEDs or LED drive circuitry
- Provides an analog identification signal at 7/8 of the LED power voltage supplied by the Target Board
- Provides patterns and support connections for driving a total of 30 self-capacitance touch sense regions arranged as 5 rows by 6 columns of square touch buttons in a square array

NOTE: The AE-CAP1-S1 Target Board cannot provide support for all 30 touch sense lines due to package pin count limitations and port pin allocations, so two buttons (ST24 and ST25) in the top row of the AE-CAP1-SC does not respond to touch actions with this Target Board.

- Includes a plastic overlay for the touch-regions of the circuit to control touch capacitance and mitigate possible ESD damage to circuitry from touch events

1.7 Usage models

The AE-CAP1 is designed as an application example kit platform as well as a preliminary software development platform for OEM applications requiring capacitive touch Human Machine Interface (HMI) and limited communications capabilities. The Target Boards have some board-to-board capable GPIO, analog, I²C, and UART interfaces available through an 8-pin header. In addition, both Target Boards provide a USB FS Device interface.

For more extensive GPIO connectivity, more flexible port assignments, and more possibilities for experimentation with MCU features, the complete Synergy DK-S3A7 or DK-S124 is recommended.

1.8 Hardware versions

This user manual is relevant to hardware version v1.1 of AE-CAP1.

1.9 Resources

- For information on programming AE-CAP1-S1, refer to *AE-CAP1 User's Manual* and *S124 User's Manual*.
- For information on programming AE-CAP1-S3, refer to *AE-CAP1 User's Manual* and *S3A7 User's Manual*.

Before programming, it is recommended you first review the Renesas e² studio or IAR EW for Synergy release notes, manuals, and application examples delivered with AE-CAP1.

2. Getting Started

The AE-CAP1 includes the two Target Boards, three Touch Application Boards, two 3 foot (91cm) USB Type A to Micro-B adapter cables, a documentation and software DVD, and the QSG. To start working with the AE-CAP1, see the included QSG.



On the Touch Application Boards, overlays are installed with plastic fasteners. Attempts to remove and/or reinstall such elements may damage fasteners, boards, or board components, and impact kit functional performance. Care should be taken if such removal is undertaken, with plastic surfaced tools preferred to minimize damage or degradation to the board and its components. Replacement of removed overlays will likely require new overlay fasteners. See the BOM for part numbers.

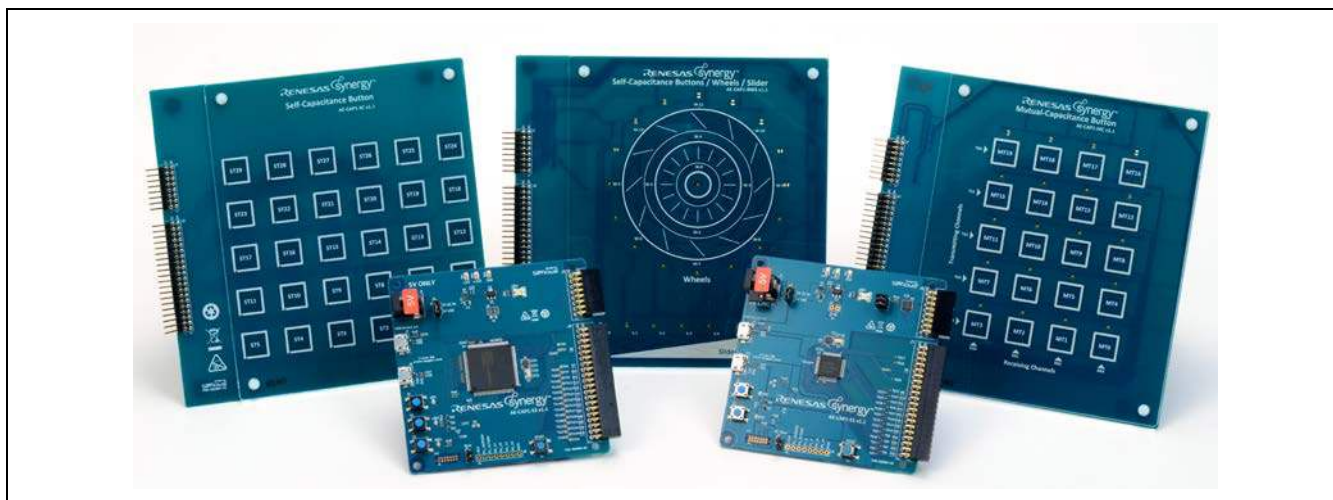

Figure 6 AE-CAP1

2.1 Powering the AE-CAP1

Prior to providing power to the selected Target Board using one of the two power options, the power jumper J2 in the “5V ONLY” labeled region of the AE-CAP1-S1 or S3 Target Board must be properly installed. For operation from the USB Device 2.0 cable power, the lower two pins should be shorted together. For operation from the Barrel connector input, the upper two pins should be shorted together.

The AE-CAP1 can be powered via two different methods:

- Installation of a 5-V power source at the 5-V external power connection, J1, on the AE-CAP1-S1 or S3 Target Board. Note that the outer sleeve of the barrel connector must be negative, and the center of the connector must be positive.
- Connection of an external USB host to the USB Device 2.0 connector adjacent to the barrel jack on the AE-CAP1-S1 or S3 Target Board.

If power is available, a green LED located upper center on the Target Board should be lit, making that LED green. If the J-Link MCU is active, it may light the red LED in the same package intermittently or solidly, making that LED appear orange.

If the jumper is improperly positioned, connection of the USB Device 2.0 jack to a USB host does not power the Target Board. Similarly, the 5-V barrel jack receives and uses power only if the jumper is appropriately positioned.



There is limited voltage protection on the 5-V direct power input: using a reverse-polarity barrel plug power source may permanently damage the unit.

2.2 Tools installation overview

The development tools e² studio and IAR EW for Synergy together with the installation guide can be downloaded from:

<https://synergygallery.renesas.com>

Specific to capacitive touch, there is another Windows PC program, Capacitive Touch Workbench for Synergy™ (CTW for Synergy), which can also be downloaded from the above website. See *Capacitive Touch Workbench for Renesas Synergy User's Manual* for installation and usage.

2.3 See the demo

A demo (pre-installed on the AE-CAP1 Target Boards) starts up when the unit is first powered. If during the course of software development this demo is erased from the flash memory, you can reload this demo from the DVD or renesas.com website and re-install it using the e² studio software development tools, the USB Type A to USB Micro-B cable, and the Segger J-Link OB (On-Board) debugger USB interface.

2.4 On-board Debugger

A Segger J-Link OB debugger microcontroller is installed on the bottom side of the AE-CAP1-S1 and AE-CAP1-S3 boards for use with the J-Link OB USB Micro-B connector interface on the Target Board adjacent to the USB Device 2.0 Micro-B connector. The Target Board must be powered from either the J1 barrel jack or the USB Device 2.0 Micro-B jack, as power is not received from the J-Link OB connector.

3. Board Layout

3.1 Component placement

The following figures show placement of individual components on side of PCBs with installed components. Component types and values can be found on the board schematics.

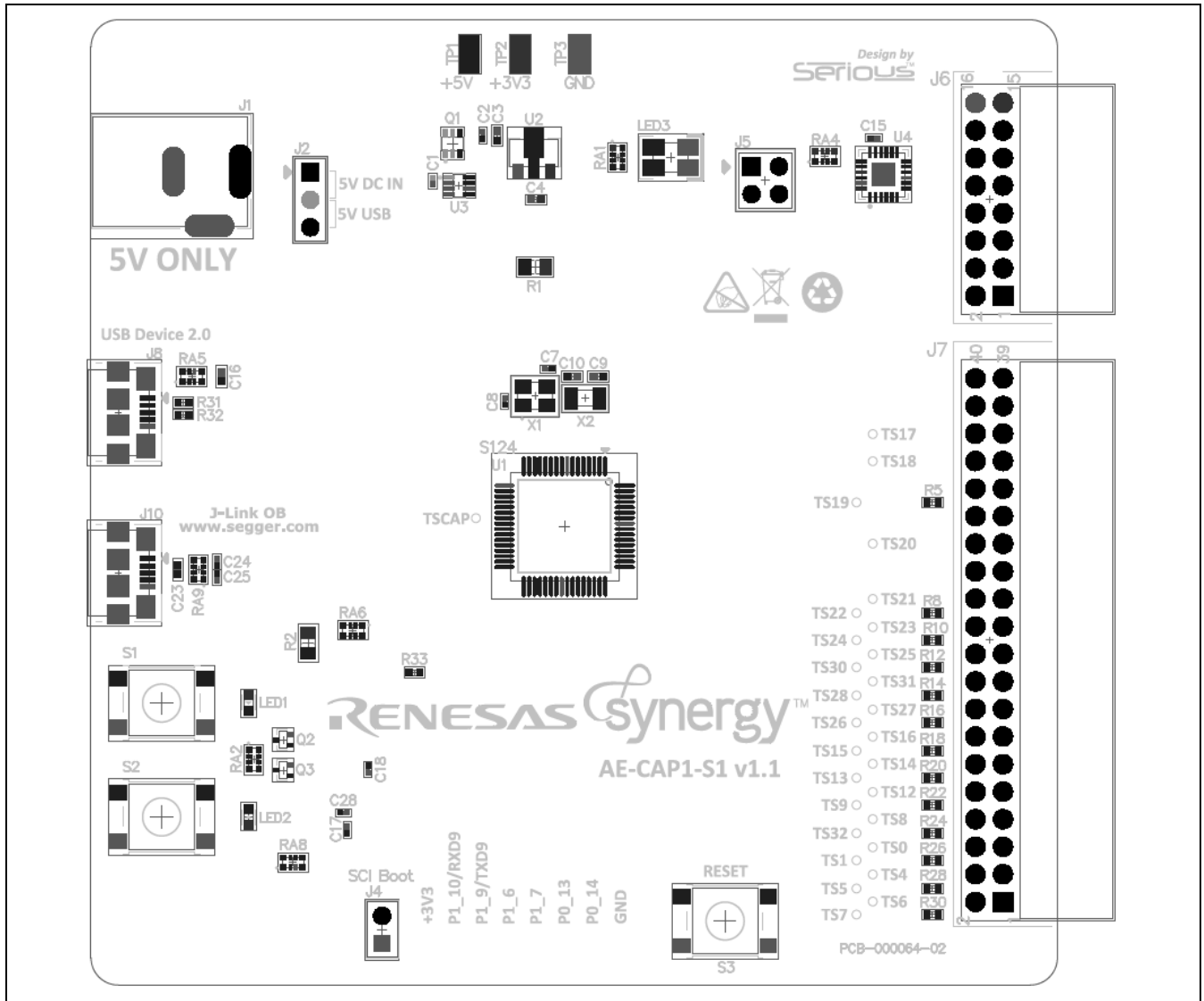

Figure 7 AE-CAP1-S1 Target Board Overall Component Placement, Top

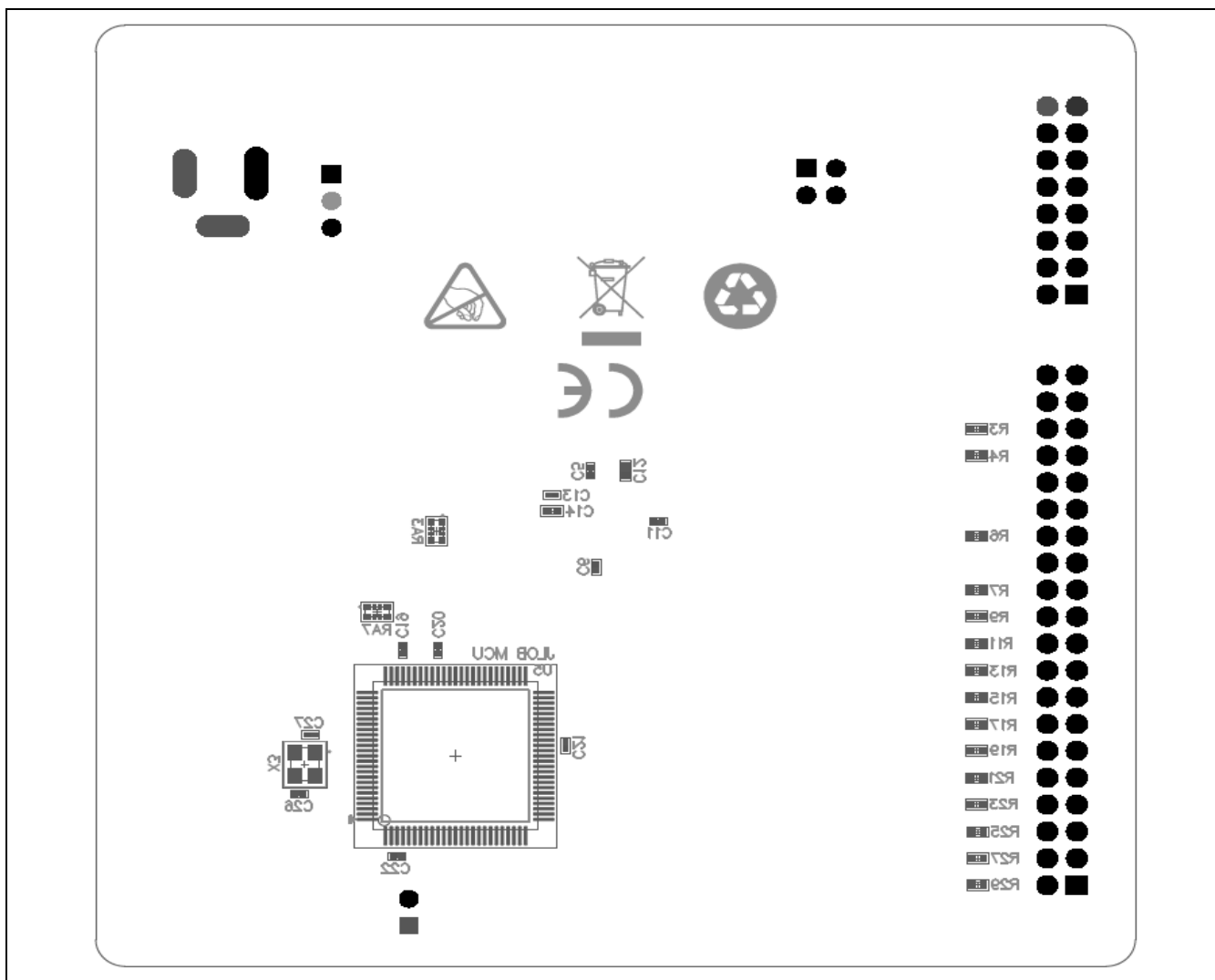

Figure 8 AE-CAP1-S1 Target Board Component Placement, Bottom

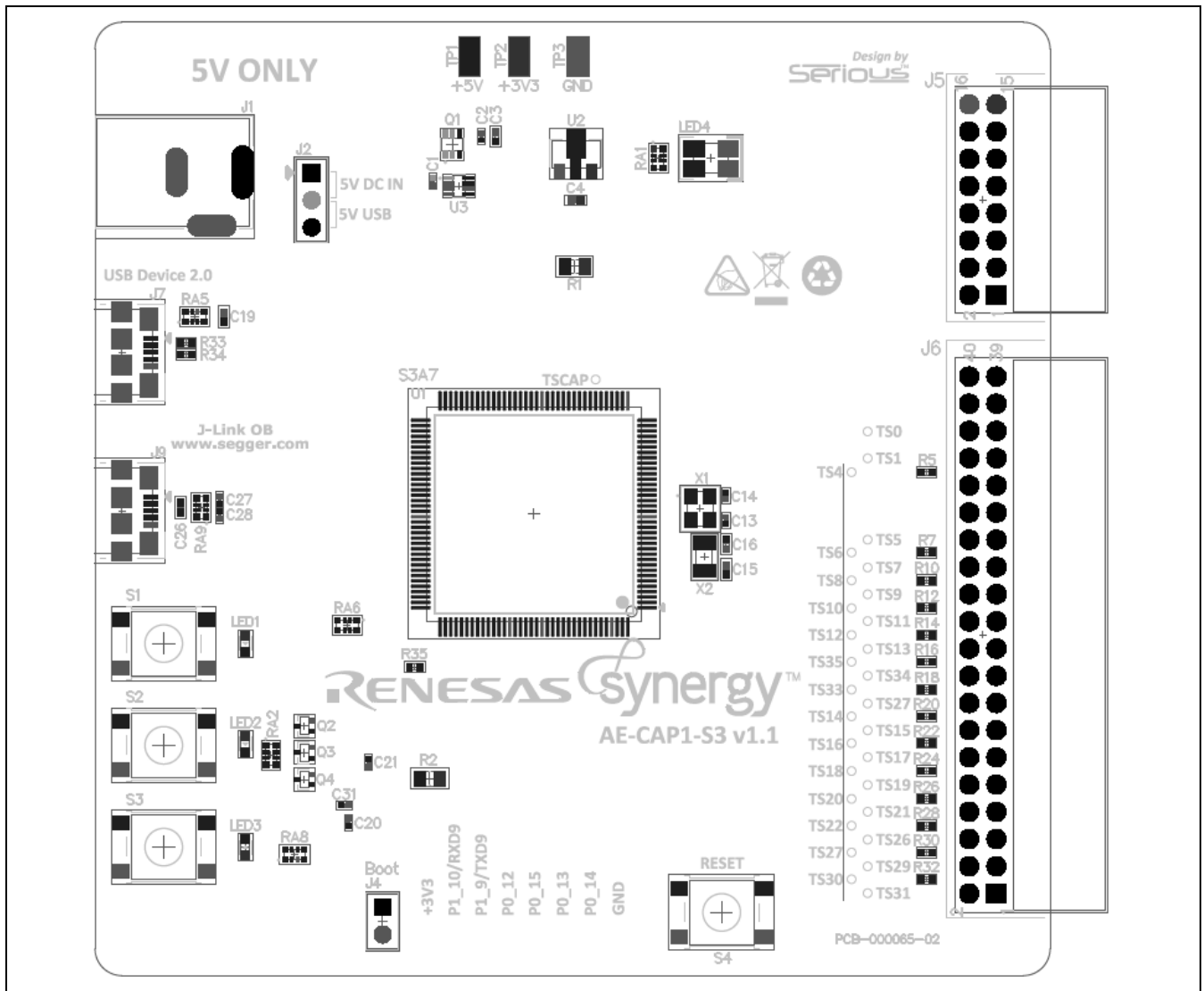

Figure 9 AE-CAP1-S3 Target Board Component Placement, Top

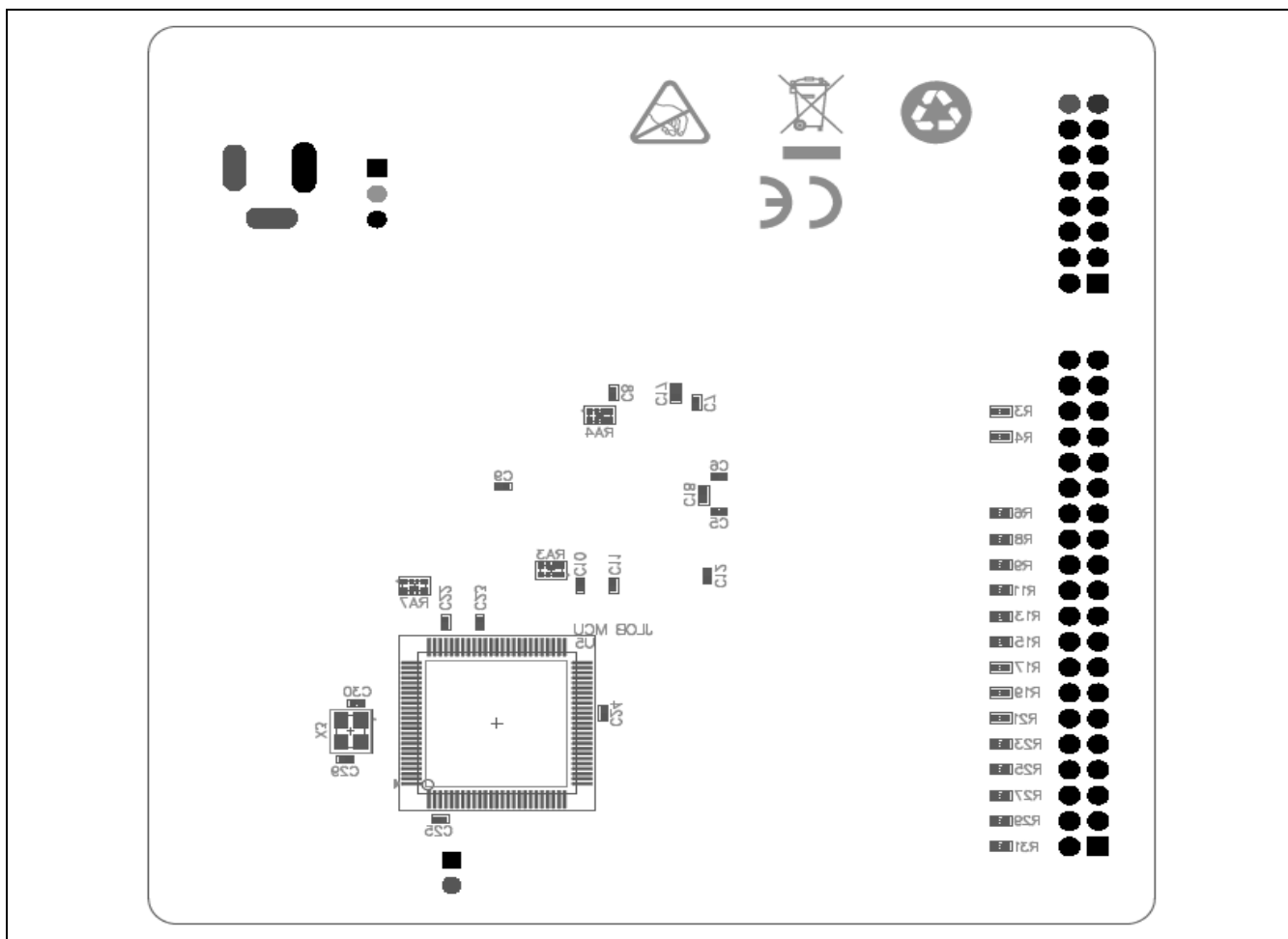

Figure 10 AE-CAP1-S3 Target Board Component Placement, Bottom

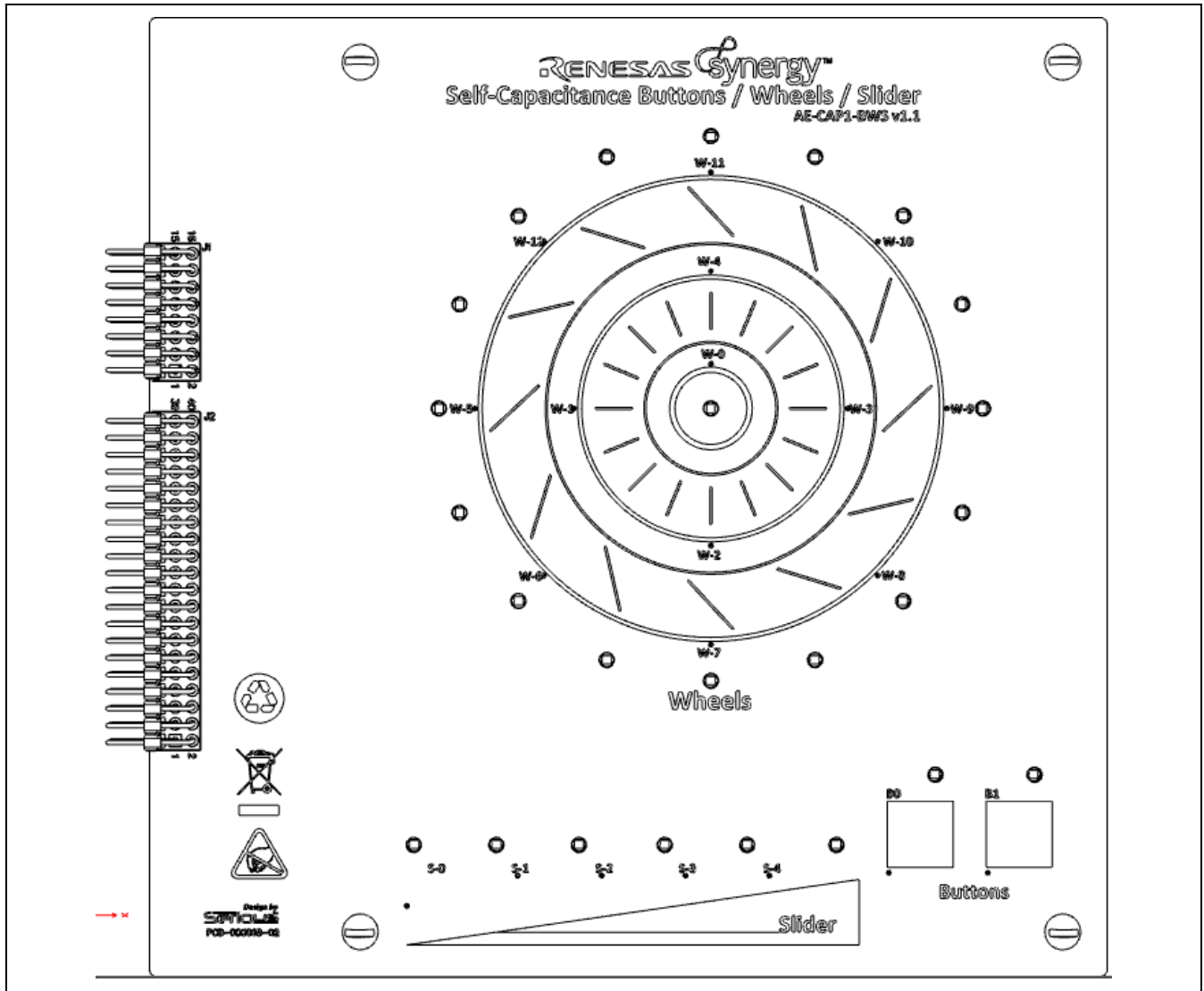

Figure 11 AE-CAP1-BWS Touch Application Board Overall Component Placement, Top

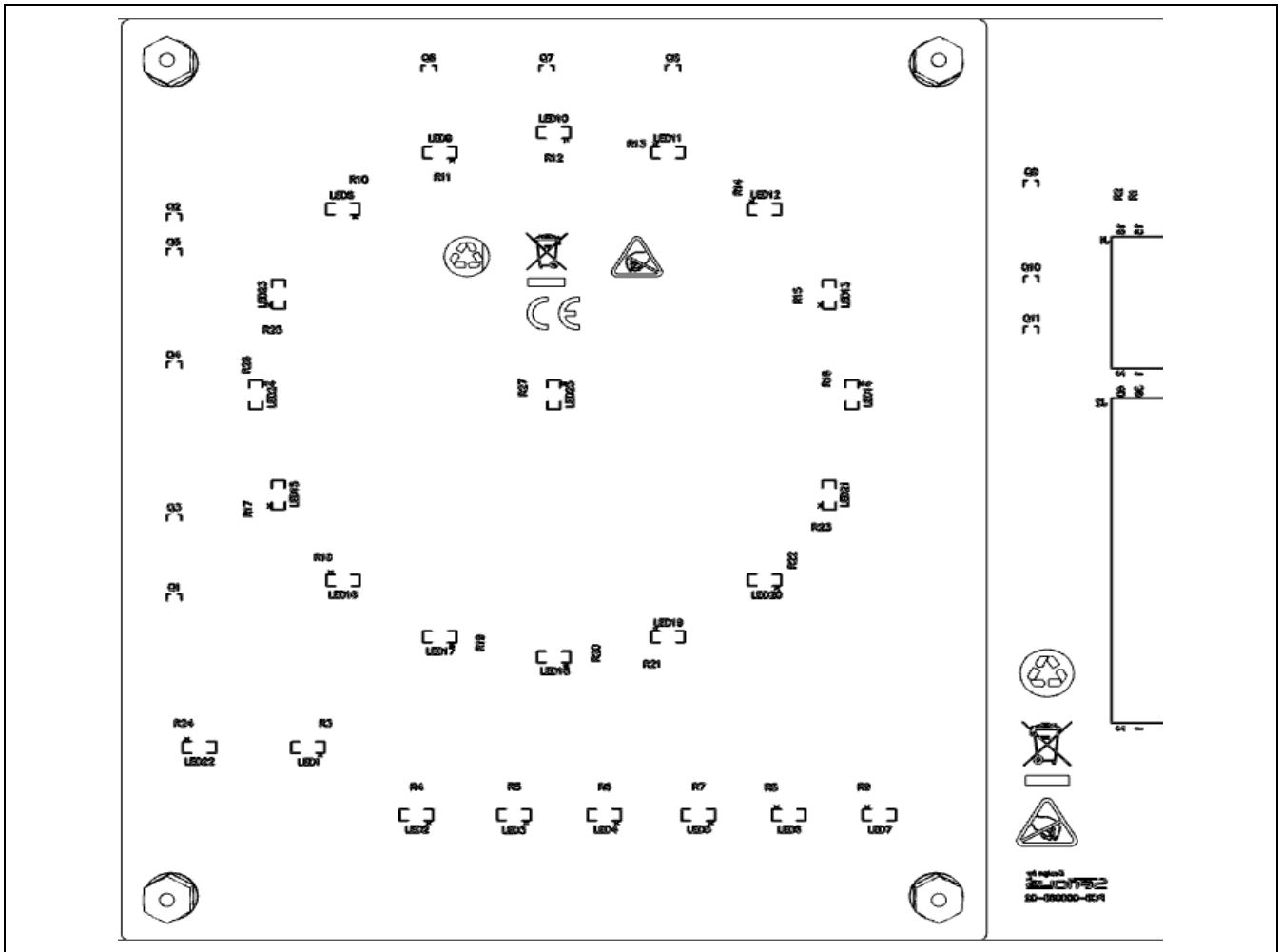

Figure 12 AE-CAP1-BWS Touch Application Board Overall Component Placement, Bottom

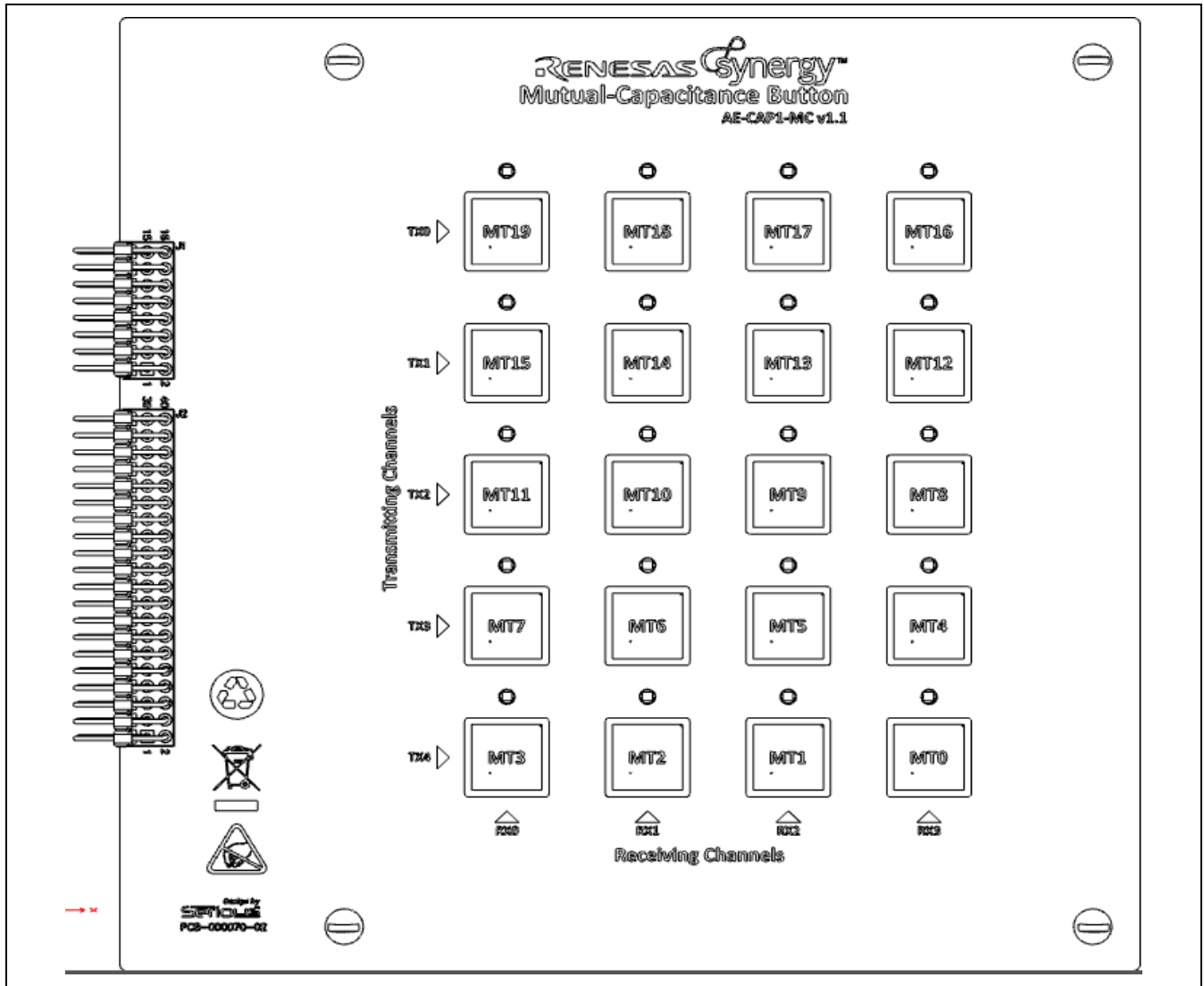

Figure 13 AE-CAP1-MC Touch Application Board Overall Component Placement, Top

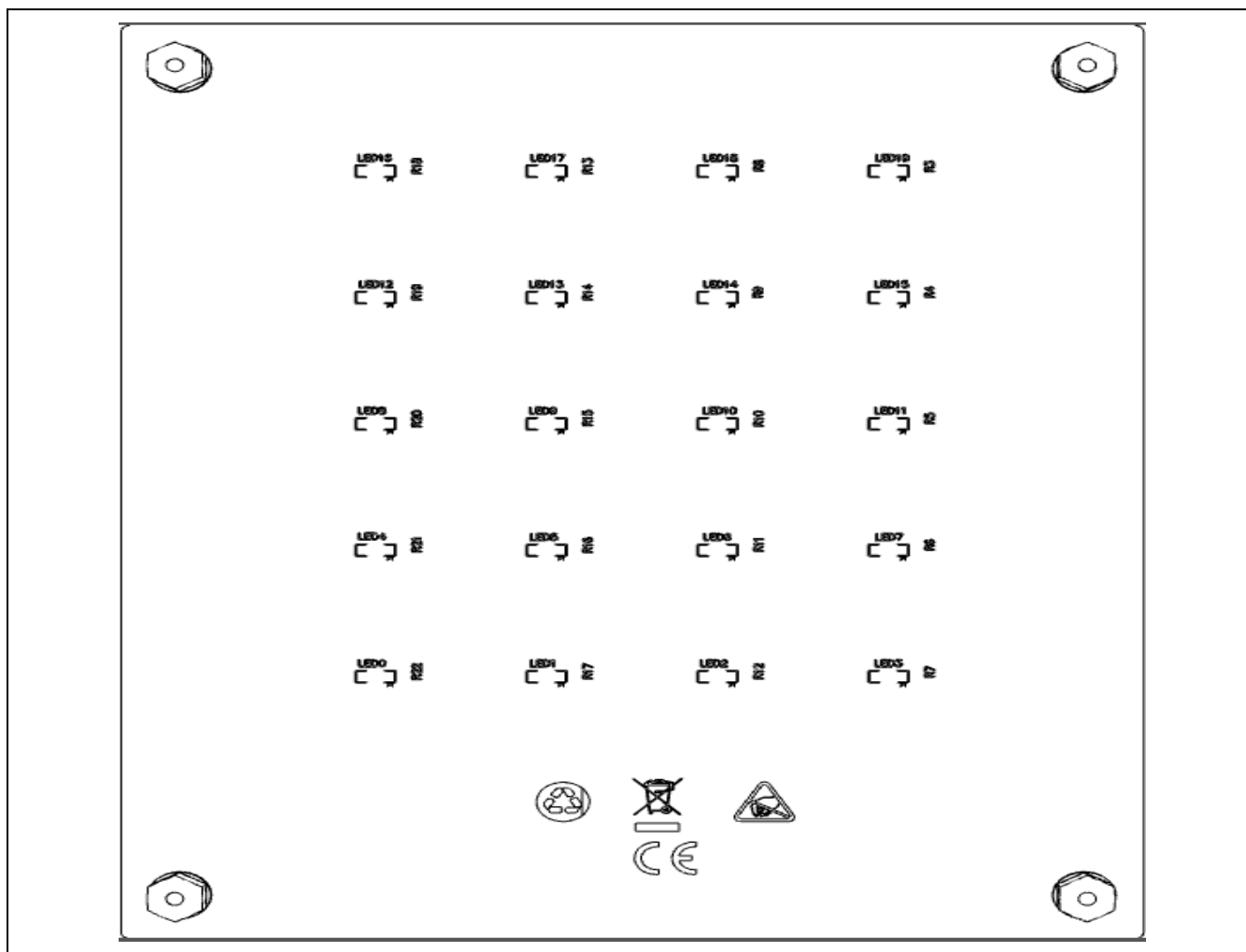

Figure 14 AE-CAP1-MC Touch Application Board Overall Component Placement, Bottom

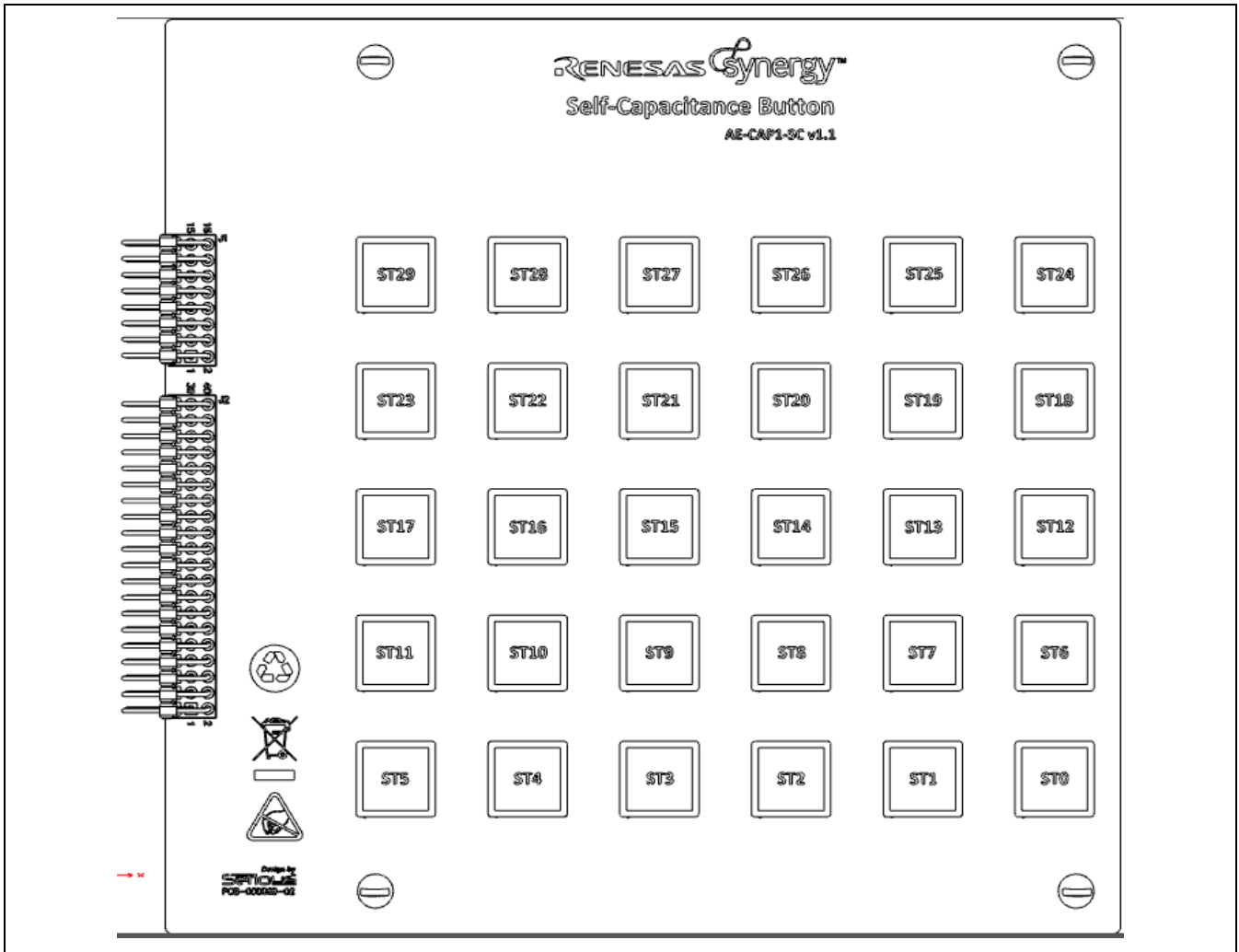

Figure 15 AE-CAP1-SC Touch Application Board Overall Component Placement, Top

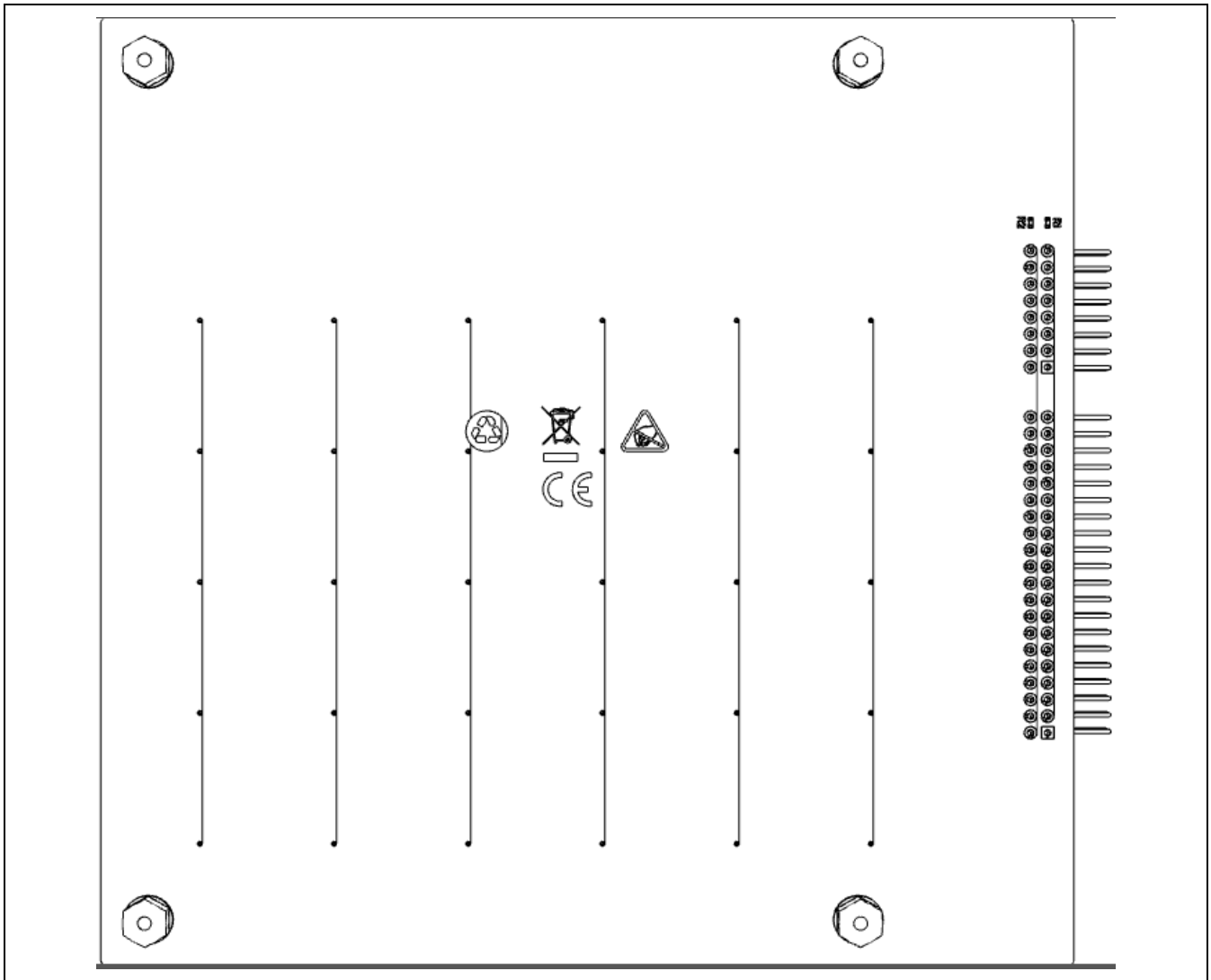

Figure 16 AE-CAP1-SC Touch Application Board Overall Component Placement, Bottom

3.2 Overlay layout

A single overlay design is used for all three touch application boards. The overlay nominal thickness is 0.120 inches. In Figure 17, all dimensions are in inches.

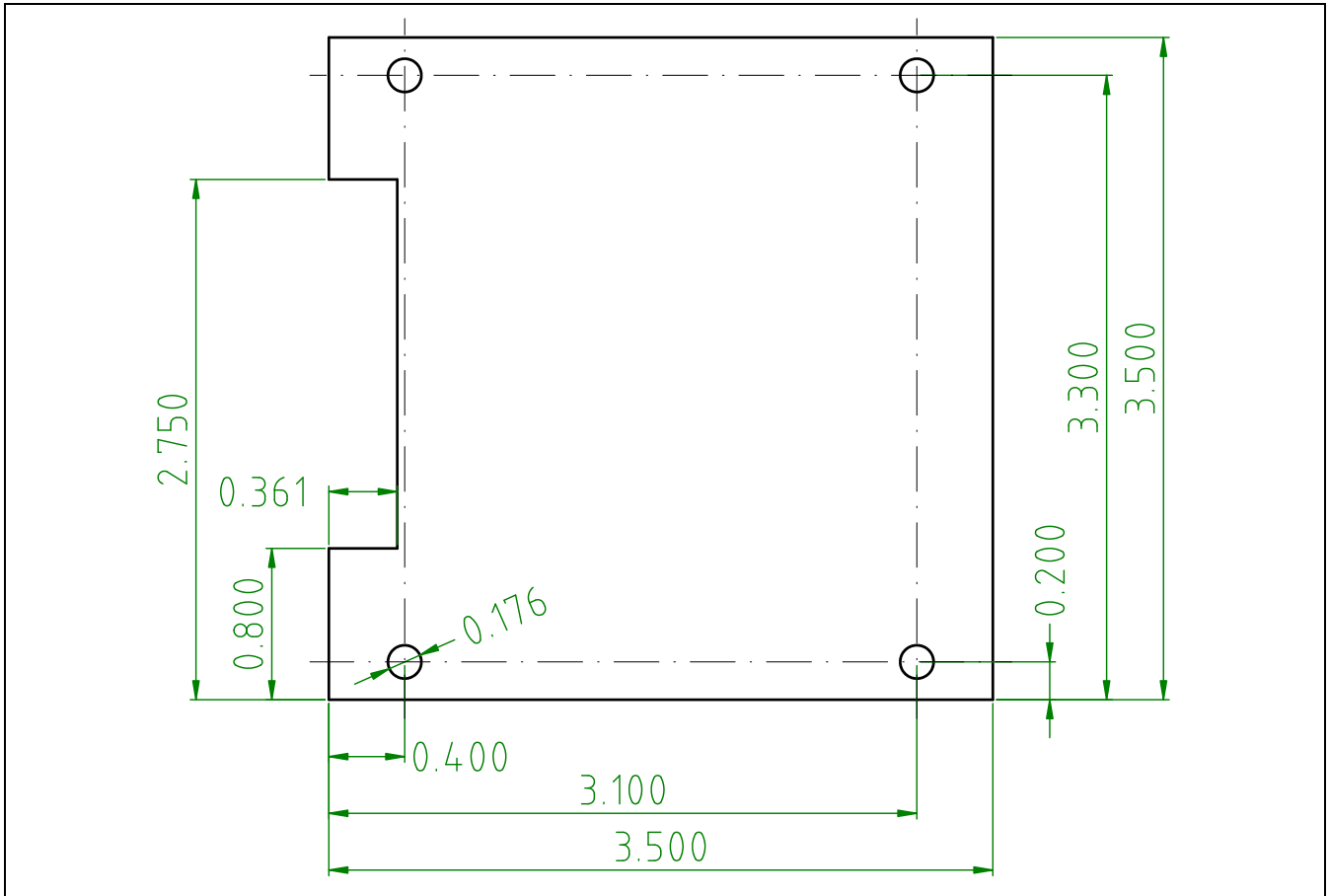

Figure 17 AE-CAP1 Touch Application Boards Overlay Layout

4. Block Diagrams

4.1 Block diagram, S1 Target Board

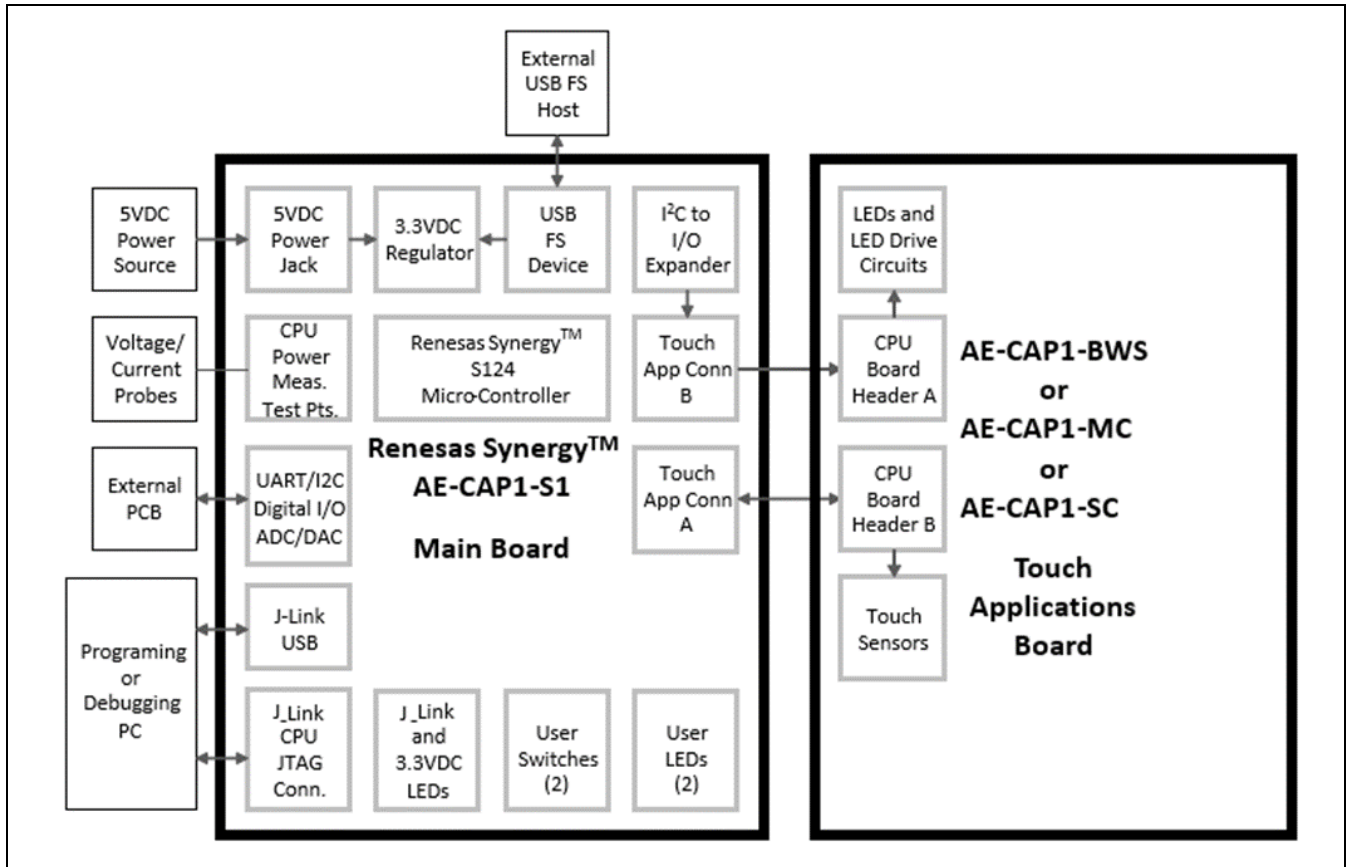

Figure 18 S1 Target Board plus application board

4.2 Block diagram, S3 Target Board

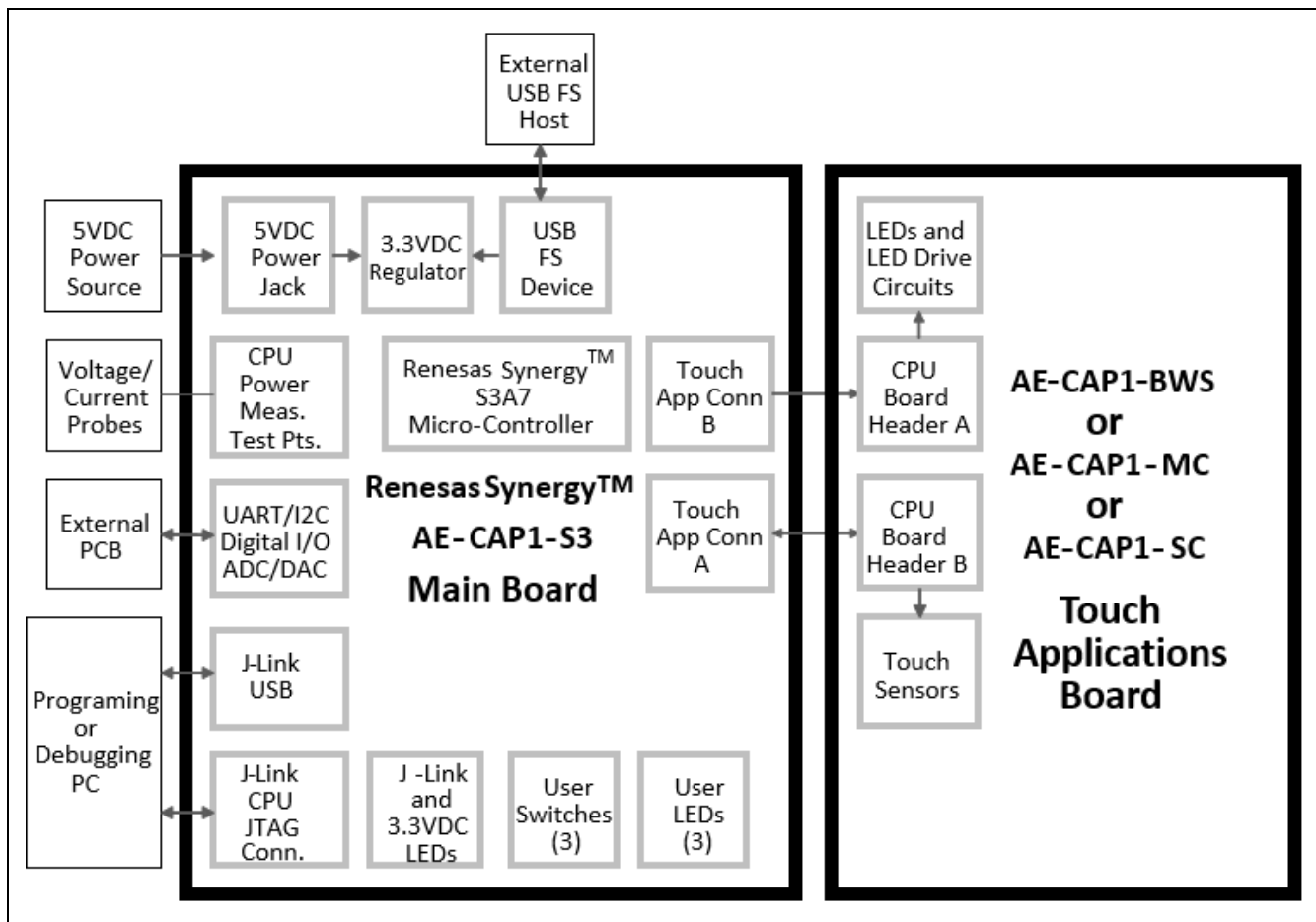

Figure 19 S3 Target Board plus application board

4.3 Touch application board variations

Three pluggable touch application boards are provided in the AE-CAP1 for attachment to the provided Target Boards. These application boards demonstrate some of the concepts and design approaches available to designers of capacitive-touch human-machine-interfaces.

4.3.1 AE-CAP1-BWS

The AE-CAP1-BWS, Button/Wheel/Slider, board provides several pattern examples for different uses of capacitive touch sensors, with all sensors of the self-capacitance type:

- Wheel having a larger outer wheel, a smaller inner wheel, and a central button
 - 8-capacitive-touch-sensor-element larger wheel, surrounded by 16 green LEDs
 - 4-capacitive -touch-sensor-element smaller wheel central to the larger wheel
 - Central capacitive-touch-sensor element button central to the two wheels, having a single green LED at its center
- Touch slider having 5 capacitive-touch-sensor elements with 6 green LEDs adjacent to the sensor elements
- Two single-capacitive-touch-sensor-element buttons, each having a single green LED adjacent to the button

See Figure 3.

4.3.2 AE-CAP1-MC

The AE-CAP1-MC, Mutual Capacitance, board provides a 4-column by 5-row array of capacitive touch sensor buttons, each having a single green LED adjacent to the button. The buttons are mutual-capacitance type for better noise performance, and an ability to directly multiplex the sensor array. In this case, 9 touch sense lines are used to interface 20 buttons.

See Figure 4.

4.3.3 AE-CAP1-SC

The AE-CAP1-SC, Self-Capacitance, board provides a 5-column by 6-row array of capacitive touch sensor buttons, with no LEDs on the board. The buttons are self-capacitance type for simplicity, but require a total of 30 touch sense lines. The AE-CAP-S1 Target Board cannot provide support for all 30 touch sense lines due to package pin count limitations and port pin allocations, so two buttons (ST24, ST25) in the top row of the AE-CAP1-SC does not respond to touch actions with this Target Board.

See Figure 5.

5. Circuitry

5.1 Power Supply

Power may be supplied to the AE-CAP1 from two sources:

- The barrel jack J1 in the upper left corner of the circuit board, with +5V to the center of the mating plug and 0V to the outer sleeve of the mating plug
- The USB Micro-B connector labeled **USB Device 2.0** adjacent to the barrel jack

As **Figure 20** shows, when power to the AE-CAP1-S1 or S3 is supplied from the barrel jack, short the upper two pins in jumper J2 (J2-1 and J2-2); otherwise, short the lower two pins in to jumper J2 (J2-2 and J2-3).

5.2 Power-up behavior

The AE-CAP1 Target Boards are delivered preloaded with a demonstration program. The demonstration program shows several features of the Target Board, and source code is available as a programming example for developers. See the QSG delivered with the AE-CAP1 for installation of the appropriate Application Board, details of use, and expected board behavior when running the demonstration program.

When powered, the green LED to the right of the barrel jack lights up. The red LED in the same LED package is controlled by the J-Link microcontroller in accordance with J-Link specifications. When both internal LEDs are lit, the LED lens appears orange.

5.3 +5-V source selection

Jumper J2 selects which power source to use with the regulator supplying circuitry on the AE-CAP1-S1 or S3 Target Board and its connected Application Board.

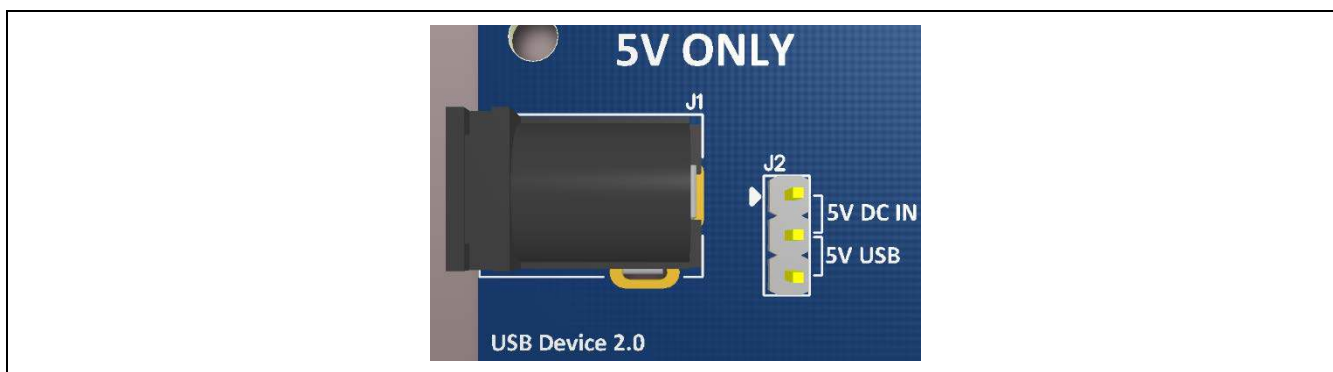

Figure 20 Jumper J2 on Target Board

5.4 3.3-V main power subsystem

Almost all the circuits on the board require 3.3 Volts, including MCU, LEDs, Application Board interface, 8-pin auxiliary interface header, and J-Link OB. The +5 V power from Jumper J2 is supplied to a 3.3-V Low Dropout Regulator that supplies 3.3 V to the Target and Application boards.

5.5 AE-CAP1-S1 programming jumper

The AE-CAP1-S1 Target Board uses an I²C port expander. The expander increases the available digital I/O capability to support Application Board LED control, while retaining as many touch sense ports as possible.

The port expander may interfere with SCI boot mode of the S124 MCU. The two horizontal jumpers installed on AE-CAP1-S1 J5 may be removed to allow SCI boot mode of the S124 MCU; however, removal of these jumpers disables LED control pins on J6.

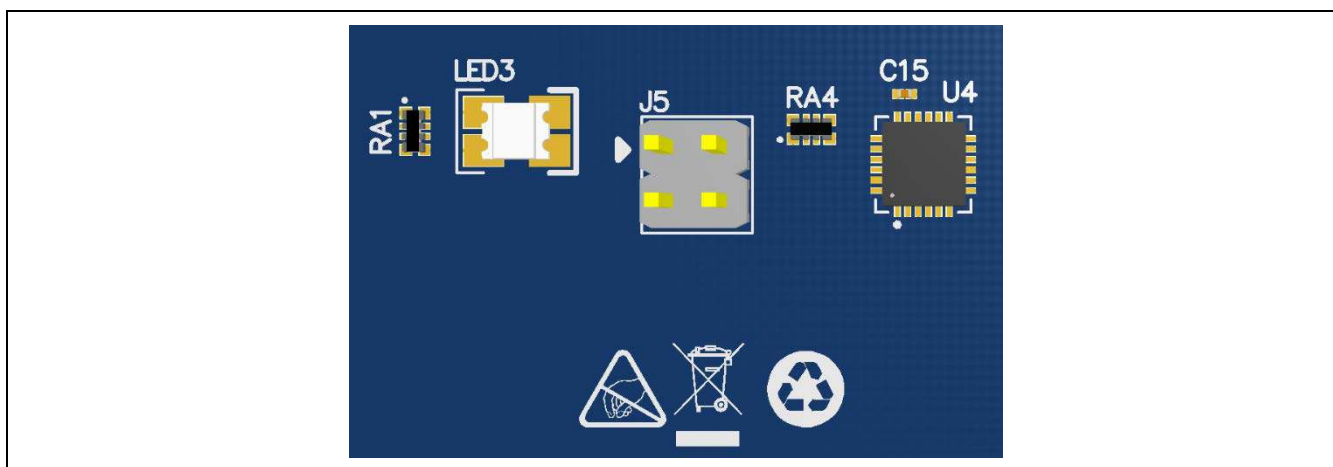

Figure 21 Jumper J5 on AE-CAP1-S1

5.6 LEDs

5.6.1 Target board LEDs

In the following table, AE-CAP1-S1 has four LEDs and AE-CAP1-S3 has five LEDs.

Table 2 Target Board LEDs

Designator		Color	Function	MCU control port		MCU pin	
S1	S3			S1	S3	S1	S3
LED1	LED1	Red	User LED	P5_1-LED1	P9_0-LED1	U1-50	U1-50
N.A.	LED2	Yellow	User LED	N.A.	P9_1-LED2	N.A.	U1-51
LED2	LED3	Green	User LED	P5_2-LED2	P9_2-LED3	U1-51	U1-52
LED3	LED4	Red	J-Link Indicator	JLED (P47)	JLED (P47)	U5-87	U5-87
LED3	LED4	Green	3.3V Power Available	+3V3	+3V3	N.A.	N.A.

5.6.2 AE-CAP1-BWS LEDs

AE-CAP1-BWS has 25 LEDs to indicate the status of touch, under the microcontroller's command. All LEDs on this board are green. All LED control signals and power are supplied through J1, CPU Board Header A, a 16-pin right-angle header connector. Positions descriptions for LEDs around the Wheel pattern are given by compass degrees on a map (0=North=top, 90=East=right, 180=South=bottom, 270=West=left).

Table 3 AE-CAP1-BWS LEDs

Designator	Row		Column		Location
	Signal	Pin	Signal	Pin	
LED1	LED_LOW0	1	LED_COL0	9	Adjacent B0 (left button)
LED2	LED_LOW1	2	LED_COL0	9	Slider rightmost end
LED3	LED_LOW2	3	LED_COL0	9	Slider between rightmost two sensors
LED4	LED_LOW3	4	LED_COL0	9	Slider between center and right-center sensors
LED5	LED_LOW4	5	LED_COL0	9	Slider between center and left-center sensors
LED6	LED_LOW5	6	LED_COL0	9	Slider between leftmost two sensors
LED7	LED_LOW6	7	LED_COL0	9	Slider leftmost end
LED8	LED_LOW0	1	LED_COL1	10	Wheel 45°
LED9	LED_LOW1	2	LED_COL1	10	Wheel 22.5°
LED10	LED_LOW2	3	LED_COL1	10	Wheel 0°
LED11	LED_LOW3	4	LED_COL1	10	Wheel 337.5°
LED12	LED_LOW4	5	LED_COL1	10	Wheel 315°
LED13	LED_LOW5	6	LED_COL1	10	Wheel 292.5°
LED14	LED_LOW6	7	LED_COL1	10	Wheel 270°
LED15	LED_LOW0	1	LED_COL2	11	Wheel 112.5°
LED16	LED_LOW1	2	LED_COL2	11	Wheel 135°
LED17	LED_LOW2	3	LED_COL2	11	Wheel 157.5°
LED18	LED_LOW3	4	LED_COL2	11	Wheel 180°
LED19	LED_LOW4	5	LED_COL2	11	Wheel 202.5°
LED20	LED_LOW5	6	LED_COL2	11	Wheel 225°
LED21	LED_LOW6	7	LED_COL2	11	Wheel 247.5°
LED22	LED_LOW0	1	LED_COL3	12	Adjacent B1 (right button)
LED23	LED_LOW1	2	LED_COL3	12	Wheel 67.5°
LED24	LED_LOW2	3	LED_COL3	12	Wheel 90°
LED25	LED_LOW3	4	LED_COL3	12	Wheel center

5.6.3 AE-CAP1-MC LEDs

AE-CAP1-MC has 20 LEDs to indicate status of touch, under microcontroller command. All LEDs on this board are green. All LED control signals and power are supplied through J1, CPU Board Header A, a 16-pin right-angle header connector. Each LED is positioned adjacent and above its intended indicating touch button.

Table 4 AE-CAP1-MC LEDs

Designator	Row		Column		Indicating Button
	Signal	Pin	Signal	Pin	
LED0	LEDR0	7	LEDC0	1	MT0
LED1	LEDR1	8	LEDC0	1	MT1
LED2	LEDR2	9	LEDC0	1	MT2
LED3	LEDR3	10	LEDC0	1	MT3
LED4	LEDR4	11	LEDC0	1	MT4
LED5	LEDR0	7	LEDC1	2	MT5
LED6	LEDR1	8	LEDC1	2	MT6
LED7	LEDR2	9	LEDC1	2	MT7
LED8	LEDR3	10	LEDC1	2	MT8
LED9	LEDR4	11	LEDC1	2	MT9
LED10	LEDR0	7	LEDC2	3	MT10
LED11	LEDR1	8	LEDC2	3	MT11
LED12	LEDR2	9	LEDC2	3	MT12
LED13	LEDR3	10	LEDC2	3	MT13
LED14	LEDR4	11	LEDC2	3	MT14
LED15	LEDR0	7	LEDC3	4	MT15
LED16	LEDR1	8	LEDC3	4	MT16
LED17	LEDR2	9	LEDC3	4	MT17
LED18	LEDR3	10	LEDC3	4	MT18
LED19	LEDR4	11	LEDC3	4	MT19

5.7 Switches

5.7.1 Target board switches

All switches are the miniature, momentary, mechanical push-button type mounted on the PCB. Pressing the MCU Reset Switch generates a reset signal to restart the Target Board MCU.

Table 5 Target Board switches

Designator		Function	MCU Control Port		MCU Pin	
S124	S3A7		S124	S3A7	S124	S3A7
S1	S1	User Switch	P1_5/IRQ0	P5_1/IRQ11	U1-43	U1-114
S2	S2	User Switch	P2_0/NMI	P5_2/IRQ12	U1-27	U1-115
N.A.	S3	User Switch	N.A.	P5_5/IRQ14	N.A.	U1-118
S3	S4	MCU Reset Switch	RESET#	RESET#	U1-25	U1-55

5.7.2 Application board switches

5.7.2.1 AE-CAP1-BWS switches

Table 6 lists the 20 switches on AE-CAP1-BWS used to sense the status of touch. Each switch is separately interfaced to MCU touch sense channels. All AE-CAP1-BWS switches use self-capacitance sensing circuitry. Eighteen switches are integrated into special-purpose patterns on the board. Eight (8) switches are located on the outer ring of the wheel, each covering about 45 degrees, but patterned so two adjacent switches are likely to be activated simultaneously to allow touch position interpolation. Four (4) switches are on the outer ring of the wheel, each covering about 90 degrees, but patterned so that two adjacent switches are likely to be activated simultaneously to allow touch position interpolation. One (1) switch is located at the center of the wheel.

The slider sensor provides five touch switches; patterned to allow multiple switch interaction for interpolation of touch position. Lastly, there are two square 10mm x 10mm switches to the lower right of the board. LEDs on this board have only a direct switch to the LED single-device correlation in three of the 20 switches. For LED location details, see Section 5.6.2. Wheel switch angular coverage arcs are shown as a range of compass degrees on a map (0=North=top, 90=East=right, 180=South=bottom, 270=West=left). For example, 270-315 is the arc from left to 45 degrees clockwise past left.

Table 6 AE-CAP1-BWS switches

App. Board marking	Schematic designator	Location	Signal name	J2 pin
B0	B0	Left Button	B0	2
B1	B1	Right Button	B1	1
S-0	S-0	Slider Left Segment	S-0	3
S-1	S-1	Slider Left-Center Segment	S-1	4
S-2	S-2	Slider Center Segment	S-2	5
S-3	S-3	Slider Right-Center Segment	S-3	6
S-4	S-4	Slider Right Segment	S-4	7
W-0	W-0	Wheel Center Button	W-0	22
W-1	W-1	Wheel Smaller, 270-360	W-1	21
W-2	W-2	Wheel Smaller, 180-270	W-2	19
W-3	W-3	Wheel Smaller, 0-90	W-3	28
W-4	W-4	Wheel Smaller, 90-180	W-4	16
W-5	W-5	Wheel Larger, 270-315	W-5	23
W-6	W-6	Wheel Larger, 225-270	W-6	20
W-7	W-7	Wheel Larger, 180-225	W-7	18
W-8	W-8	Wheel Larger, 135-180	W-8	17
W-9	W-9	Wheel Larger, 90-135	W-9	8
W-10	W-10	Wheel Larger, 45-90	W-10	36
W-11	W-11	Wheel Larger, 0-45	W-11	34
W-12	W-12	Wheel Larger, 315-360	W-12	31

5.7.2.2 AE-CAP1-MC switches

Table 7 lists the 20 switches on the AE-CAP1-MC used to sense the status of touch, with rows/columns scanned under the MCU's command. All switches on this board are associated with a green LED. All switch sense signals are routed through connector J2, CPU Board Header B, a 40-pin right-angle header connector. Switches are approximately 10mm by 10mm in size and located on 20mm by 20mm array centers. In **Table 7**, the switch location is recorded in the form "R2C3" where the digit following 'R' indicates the horizontal row, with 0 at the top and 4 at the bottom, and the digit following 'C' indicates the vertical column, with 0 at the left and 3 at the right.

Table 7 AE-CAP1-MC switches

Board and schematic designator	Switch location	Row		Column		Indicating LED
		Signal	Pin	Signal	Pin	
MT0	R4C3	TXR4	10	RXC3	36	LED0
MT1	R4C2	TXR4	10	RXC2	34	LED1
MT2	R4C1	TXR4	10	RXC1	31	LED2
MT3	R4C0	TXR4	10	RXC0	28	LED3
MT4	R3C3	TXR3	9	RXC3	36	LED4
MT5	R3C2	TXR3	9	RXC2	34	LED5
MT6	R3C1	TXR3	9	RXC1	31	LED6
MT7	R3C0	TXR3	9	RXC0	28	LED7
MT8	R2C3	TXR2	8	RXC3	36	LED8
MT9	R2C2	TXR2	8	RXC2	34	LED9
MT10	R2C1	TXR2	8	RXC1	31	LED10
MT11	R2C0	TXR2	8	RXC0	28	LED11
MT12	R1C3	TXR1	7	RXC3	36	LED12
MT13	R1C2	TXR1	7	RXC2	34	LED13
MT14	R1C1	TXR1	7	RXC1	31	LED14
MT15	R1C0	TXR1	7	RXC0	28	LED15
MT16	R0C3	TXR0	6	RXC3	36	LED16
MT17	R0C2	TXR0	6	RXC2	34	LED17
MT18	R0C1	TXR0	6	RXC1	31	LED18
MT19	R0C0	TXR0	6	RXC0	28	LED19

5.7.2.3 AE-CAP1-SC switches

Table 8 lists the 30 switches on the AE-CAP1-SC to sense status of touch; each switch separately interfaced to the MCU's touch sense channels. All AE-CAP1-SC switches use self-capacitance sensing circuitry. Switch location is recorded in the form "R2C4" where the digit following 'R' indicates the horizontal row, with 0 at the bottom and 4 at the top, and the digit following 'C' indicates the vertical column, with 0 at the right and 5 at the left. The AE-CAP1-S1 Target Board does not provide sufficient signals to operate all keys on the AE-CAP-SC Application Board. The rightmost columns indicate availability of the self-capacitance sense line from the microcontroller for these boards.

Table 8 AE-CAP1-SC switches

Board and schematic designator	Switch location	Signal	J2 pin	S124 avail?	S3A7 avail?
ST0	R0C0	ST0	1	Yes	Yes
ST1	R0C1	ST1	2	Yes	Yes
ST2	R0C2	ST2	3	Yes	Yes
ST3	R0C3	ST3	4	Yes	Yes
ST4	R0C4	ST4	5	Yes	Yes
ST5	R0C5	ST5	6	Yes	Yes
ST6	R1C0	ST6	7	Yes	Yes
ST7	R1C1	ST7	8	Yes	Yes
ST8	R1C2	ST8	9	Yes	Yes
ST9	R1C3	ST9	10	Yes	Yes
ST10	R1C4	ST10	11	Yes	Yes
ST11	R1C5	ST11	12	Yes	Yes
ST12	R2C0	ST12	13	Yes	Yes
ST13	R2C1	ST13	14	Yes	Yes
ST14	R2C2	ST14	15	Yes	Yes
ST15	R2C3	ST15	16	Yes	Yes
ST16	R2C4	ST16	17	Yes	Yes
ST17	R2C5	ST17	18	Yes	Yes
ST18	R3C0	ST18	19	Yes	Yes
ST19	R3C1	ST19	20	Yes	Yes
ST20	R3C2	ST20	21	Yes	Yes
ST21	R3C3	ST21	22	Yes	Yes
ST22	R3C4	ST22	23	Yes	Yes
ST23	R3C5	ST23	24	Yes	Yes
ST24	R4C0	ST24	25	No	Yes
ST25	R4C1	ST25	26	No	Yes
ST26	R4C2	ST26	27	Yes	Yes
ST27	R4C3	ST27	28	Yes	Yes
ST28	R4C4	ST28	29	Yes	Yes
ST29	R4C5	ST29	30	Yes	Yes

5.8 Button to MCU sense map

Table 9 through Table 12 lists the mapping of self-capacitance buttons in a form designed for code development. Data has been extracted from **Table 14** and, in the case of the AE-CAP-MC, also from **Table 7**.

Table 9 AE-CAP1-S1 Target Board to AE-CAP1-BWS Application Board

		W-11/TS18			
	W-12/TS19	W-4/TS20	W-10/TS17		
W-5/TS22	W-1/TS24	W-0/TS23	W-3/TS27	W-9/TS8	
	W-6/TS25	W-2/TS30	W-8/TS28		
		W-7/TS31			
				B0/TS6	B1/TS7
S-0/TS5	S-1/TS4	S-2/TS1	S-3/TS0	S-4/TS2	

- Notes:** 1. Pattern of table is pattern of buttons on Application Board.
2. B#, S#, W-# are AE-CAP1-BWS board button designators, TS# is AE-CAP1-S1 MCU touch sense signal line.

Table 10 AE-CAP1-S3 Target Board to AE-CAP1-BWS Application Board

		W-11/TS1			
	W-12/TS4	W-4/TS5	W-10/TS0		
W-5/TS28	W-1/TS10	W-0/TS11	W-3/TS32	W-9/TS21	
	W-6/TS13	W-2/TS12	W-8/TS35		
		W-7/TS34			
				B0/TS31	B1/TS30
S-0/TS27	S-1/TS29	S-2/TS22	S-3/TS26	S-4/TS20	

- Notes:** 1. Pattern of table is pattern of buttons on Application Board.
2. B#, S#, W-# are AE-CAP1-BWS board button designators, TS# is AE-CAP1-S3 MCU touch sense signal line.

Table 11 AE-CAP1-S1 Target Board to AE-CAP1-MC Application Board

MT19/TS0/TS20	MT18/TS0/TS19	MT17/TS0/TS18	MT16/TS0/TS17
MT15/TS2/TS20	MT14/TS2/TS19	MT13/TS2/TS18	MT12/TS2/TS17
MT11/TS8/TS20	MT10/TS8/TS19	MT9/TS8/TS18	MT8/TS8/TS17
MT7/TS9/TS20	MT6/TS9/TS19	MT5/TS9/TS18	MT4/TS9/TS17
MT3/TS12/TS20	MT2/TS12/TS19	MT1/TS12/TS18	MT0/TS12/TS17

- Notes:** 1. Pattern of table is pattern of buttons on Application Board.
2. MT# is AE-CAP1-MC board button designator, next two TS# entries are the transmit row and receive column touch sense channels respectively for the AE-CAP1-S1 Target Board.

Table 12 AE-CAP1-S3 Target Board to AE-CAP1-MC Application Board

MT19/TS26/TS5	MT18/TS26/TS4	MT17/TS26/TS1	MT16/TS26/TS0
MT15/TS20/TS5	MT14/TS20/TS4	MT13/TS20/TS1	MT12/TS20/TS0
MT11/TS21/TS5	MT10/TS21/TS4	MT9/TS21/TS1	MT8/TS21/TS0
MT7/TS18/TS5	MT6/TS18/TS4	MT5/TS18/TS1	MT4/TS18/TS0
MT3/TS19/TS5	MT2/TS19/TS4	MT1/TS19/TS1	MT0/TS19/TS0

Notes: 1. Pattern of table is pattern of buttons on the Application Board
 2. MT# is AE-CAP1-MC board button designator, next two TS# entries are the transmit row and receive column touch sense channels respectively for the AE-CAP1-S1 Target Board.

5.9 Target to app board connectors

The Target Boards, AE-CAP1-S1 and AE-CAP-S3, each have two right-angle female header connectors on their right edge. The Target Board connectors connect to the touch Application Boards: AE-CAP1-BWS, AE-CAP1-MC, or AE-CAP1-SC. The Application Boards have two right-angle male-header connectors on their left edge. The Target Board connectors mate to provide mechanical support, power, and signals to operate the touch Application Board. Connect only a Target Board to a touch Application Board.

5.9.1 Connector A

- On the Target Board schematic, connector A is labeled “Touch APP Connector A” to designate its destination.
- On the touch Application Board, connector A is labeled “Target Board Header A”, to designate its source.
- Connector A carries LED and identifier power, LED digital level control signals from the MCU, and an analog identifier voltage from a resistive divider network to the MCU.

Table 13 Connector A pin assignment

Pin	S1 board connection	S3 board connection	BWS board connection	MC board connection	SC board connection
1	XP0_7	P1_7	LED_LOW0	LEDC0	N.C.
2	XP0_6	P1_6	LED_LOW1	LEDC1	N.C.
3	XP0_5	P1_5	LED_LOW2	LEDC2	N.C.
4	XP0_4	P1_4	LED_LOW3	LEDC3	N.C.
5	XP0_3	P1_3	LED_LOW4	N.C.	N.C.
6	XP0_2	P1_2	LED_LOW5	N.C.	N.C.
7	XP0_1	P1_1	LED_LOW6	LEDR0	N.C.
8	XP0_0	P1_0	N.C.	LEDR1	N.C.
9	XP0_11	P3_7	LED_COL0	LEDR2	N.C.
10	XP0_10	P3_6	LED_COL1	LEDR3	N.C.
11	XP0_9	P3_5	LED_COL2	LEDR4	N.C.
12	XP0_8	P3_4	LED_COL3	N.C.	N.C.
13	N.C.	N.C.	N.C.	N.C.	N.C.
14	P0_12/AN007	P0_9/AN009	ADC	ADC	ADC
15	+3V3	+3V3	VCC_LED	VCC_LED	VCC_LED
16	GND	GND	VSS_LED	VSS_LED	VSS_LED

Notes: 1. S1 Target Board interface to connector B is through an I²C port expander, nominally an NXP PCAL9535A. S1 Board Connection designators correlate to data sheet designators such that XP0_0 is part P0_0, sequentially through XP0_7 matching XP0_7, then XP0_8 matches P1_0, sequentially through XP0_11 matching P1_3. The I²C 7-bit address will be 0100101b.

2. BWS LED_LOW# entries are pull-low-row transistor controls for LEDs, LED_COL# entries are pull-high-column transistor controls for LEDs. ADC value for BWS is 5/8 of the voltage VCC_LED, reference VSS_LED.
3. MC LEDR# entries are pull-high-row transistor controls for LEDs, LEDC# entries are pull-low-column transistor controls for LEDs. ADC value for MC is 3/8 of the voltage VCC_LED, reference VSS_LED.
4. SC Application Board has no LEDs. ADC value for SC is 1/8 of the voltage VCC_LED, reference VSS_LED.

5.9.2 Connector B

- On the Target Board schematic, connector B is labeled “Touch APP Connector B” to designate its destination.
- On the touch Application Board, connector B is labeled “Target Board Header B”, to designate its source.

Table 14 Connector B pin assignment

Pin	S1 Board Connection	S3 Board Connection	BWS Board Connection	MC Board Connection	SC Board Connection
1	P4_11/TS7	P0_10/TS30	B1	N.C.	ST0
2	P4_10/TS6	P0_11/TS31	B0	N.C.	ST1
3	P4_9/TS5	P0_6/TS27	S-0	N.C.	ST2
4	P4_8/TS4	P0_8/TS29	S-1	N.C.	ST3
5	P2_6/TS1	P0_1/TS22	S-2	N.C.	ST4
6	P2_4/TS0	P0_5/TS26	S-3	TxR0	ST5
7	P3_3/TS2	P4_0/TS20	S-4	TxR1	ST6
8	P3_2/TS8	P0_0/TS21	W-9	TxR2	ST7
9	P3_1/TS9	P4_2/TS18	N.C.	TxR3	ST8
10	P1_11/TS12	P4_1/TS19	N.C.	TxR4	ST9
11	P1_4/TS13	P4_4/TS16	N.C.	N.C.	ST10
12	P1_3/TS14	P4_3/TS17	N.C.	N.C.	ST11
13	P1_2/TS15	P4_6/TS14	N.C.	N.C.	ST12
14	P1_1/TS16	P4_5/TS15	N.C.	N.C.	ST13
15	P1_0/TS26	P7_1/TS33	N.C.	N.C.	ST14
16	P5_0/TS27	P7_0/TS32	W-3	N.C.	ST15
17	P0_15/TS28	P7_10/TS35	W-8	N.C.	ST16
18	P0_11/TS31	P7_2/TS34	W-7	N.C.	ST17
19	P0_10/TS30	P7_8/TS12	W-2	N.C.	ST18
20	P0_4/TS25	P7_9/TS13	W-6	N.C.	ST19
21	P0_3/TS24	P4_14/TS10	W-1	N.C.	ST20
22	P0_2/TS23	P4_15/TS11	W-0	N.C.	ST21
23	P0_1/TS22	P4_12/TS8	W-5	N.C.	ST22
24	P0_0/TS21	P4_13/TS9	N.C.	N.C.	ST23
25	N.C.	P4_10/TS6	N.C.	N.C.	ST24
26	N.C.	P4_11/TS7	N.C.	N.C.	ST25
27	N.C.	N.C.	N.C.	N.C.	N.C.
28	P4_0/TS20	P4_9/TS5	W-4	RxC0	ST26
29	N.C.	N.C.	N.C.	N.C.	N.C.
30	N.C.	N.C.	N.C.	N.C.	N.C.
31	P4_1/TS19	P4_8/TS4	W-12	RxC1	ST27
32	N.C.	N.C.	N.C.	N.C.	N.C.
33	N.C.	N.C.	N.C.	N.C.	N.C.

Pin	S1 Board Connection	S3 Board Connection	BWS Board Connection	MC Board Connection	SC Board Connection
34	P4_2/TS18	P2_6/TS1	W-11	RxC2	ST28
35	N.C.	N.C.	N.C.	N.C.	N.C.
36	P4_3/TS17	P2_4/TS0	W-10	RxC3	ST29
37	N.C.	N.C.	N.C.	N.C.	N.C.
38	N.C.	N.C.	N.C.	N.C.	N.C.
39	N.C.	N.C.	N.C.	N.C.	N.C.
40	N.C.	N.C.	N.C.	N.C.	N.C.

- Notes:**
1. BWS Application Board B# are buttons, S-# are slider pads, W-# are wheel pattern pads.
 2. MC Application Board TxR# are excitation signals from the Target Board to couple into # button row, RxC# are the coupled signal from each column through the excited buttons for detection by the Target Board.
 3. SC Application Board – note that when the S1 Target Board is in use, there are two inoperable buttons at the top right corner of the button array, due to touch-sense signal count limitations, buttons ST24 and ST25.

5.10 USB device

The USB Micro-B connection jack connects the MCU to an external USB Host, FS capable, and receives power from the host PC.

Table 15 USB device connector

USB device connector		AE-CAP1-S1	AE-CAP1-S3
Pin	Description	Signal/Bus	Signal/Bus
1	+5VDC, connected to +5VUSB, also includes a sense voltage 2/3 divider to allow MCU sensing	+5VUSB P4_7/USB_VBUS = 2/3 VUSB	+5VUSB P4_7/USB_VBUS = 2/3 VUSB
2	Data-	USB_DM	USB_DM
3	Data+	USB_DP	USB_DP
4	USB ID, jack internal switch, cable inserted	N.C.	N.C.
5	Ground	GND	VSS

5.11 J-Link OB USB

The USB Micro-B connection jack connects the J-Link MCU to an external USB Host, FS capable, allowing re-programming and debugging of the target MCU firmware. Power for the Target Boards is not received from this connector.



Table 16 J-Link USB connector (J14)

J-Link OB USB Connector		AE-CAP1-S1	AE-CAP1-S3
Pin	Description	Signal/Bus	Signal/Bus
1	+5VDC	N.C.	N.C.
2	Data-	J-Link MCU USB0_DM	J-Link MCU USB0_DM
3	Data+	J-Link MCU USB0_DP	J-Link MCU USB0_DP
4	USB ID, jack internal switch, cable inserted	N.C.	N.C.
5	Ground	GND	GND

5.12 USB cables

AE-CAP1 provides two three-foot USB cables. The connector on one end is Type A for insertion into a PC or other USB Host jack. The connector on the second is Micro-B for insertion into either the USB Device 2.0 or the J-Link OB jack on the Target Board. Connecting both cables allows powering the board from the USB Device 2.0 connection while debugging the board from the J-Link OB connection.



5.13 External power supply

The AE-CAP1 is intended to be used with the USB cable providing power, but a barrel jack is also provided on the main board for an external 5V source. An AC to DC power converter, wall mounted may be used with the AE-CAP1, plugged into J1 near the upper left corner of the main board. A suitable converter may be Triad part number WSU050-1500, or a CUI Inc. SWI6-5-N-P5, both available from several distributors.

5.14 Port numbering

The Renesas Data Sheets for the MCUs generally refer to ports with numbers like “P001”, “P110”, and similar. This document generally refers to these ports as “P0_1” and “P1_10” respectively to add clarity. Port 5 bit 15 would be referred to in the data sheet as “P515”, in this manual as “P5_15”. The two forms should be considered identical in meaning.

6. Glossary

6.1 Abbreviations and acronyms

AC	Alternating Current	KB	Kilo Byte (1024 bytes = 1 KB)
ADC	Analog to Digital Converter	kHz	103 Hertz
API	Application Programming Interface	LDO	Low Drop Out (voltage regulator)
App	Application	LED	Light Emitting Diode
ARM	Advanced RISC Machine	Max	Maximum
Avail?	Availability for specified board	MCU	Micro Controller Unit
CE	EU conformity marking for products	MHz	106 Hertz
cm	centimeter	mm	millimeter
ctr	center	mV	milli Volt
DAC	Digital to Analog Converter	mW	milli Watt
DC	Direct Current	N.A.	Not Applicable
DVD	digital video disc	N.C.	Not Connected
EMC	Electromagnetic Compatibility	NXP	Company name, previously Phillips Electronics
ESD	Electrostatic Discharge	OB	On Board
EU	European Union	OD	outside diameter
FCC	U.S. Federal Communications Commission	OEM	Original Equipment Manufacturer
FS	Full Speed (USB communications)	OVP	Over Voltage Protection
GPIO	General Purpose Input Output	PC	Personal Computer
HMI	Human Machine Interface	PCB	Printed Circuit Board
I/O	Input / Output	QSG	Quick Start Guide
I ² C	Inter Integrated Circuit Serial Comms Bus	RH	Relative Humidity in percent
ID	inside diameter	RoHS	Restriction of Hazardous Substances in Electronic Equipment Directive
IoT	Internet of Things	RTCC	Real Time Clock Calendar
I _q	quiescent current draw	SRAM	Static Random Access Memory
ISDE	Integrated Solution Development Environment	std	standard
JLOB	Segger J-Link On Board interface	SWD	Serial Wire Debug
k	kilo (1000)		

Typ	Typical	Vcc	Positive supply voltage for some circuits
UART	Universal Asynchronous Receiver Transmitter	VDC	Volts DC
UL	Underwriters Laboratories	W	Watt
USB	Universal Serial Bus	WEEE	EC Waste Electrical and Electronic Equipment Directive
UVP	Under Voltage Protection	ZIP	compressed file ending in “.zip”
V	Volt		

Revision History

Rev.	Date	Description	
		Page	Summary
1.00	May 8, 2017	-	First release

Application Example for Capacitive Touch (AE-CAP1) User's Manual

Publication Date: Rev.1.00 May 8, 2017

Published by: Renesas Electronics Corporation

**SALES OFFICES****Renesas Electronics Corporation**<http://www.renesas.com>Refer to "<http://www.renesas.com/>" for the latest and detailed information.**Renesas Electronics America Inc.**2801 Scott Boulevard Santa Clara, CA 95050-2549, U.S.A.
Tel: +1-408-588-6000, Fax: +1-408-588-6130**Renesas Electronics Canada Limited**9251 Yonge Street, Suite 8309 Richmond Hill, Ontario Canada L4C 9T3
Tel: +1-905-237-2004**Renesas Electronics Europe Limited**Dukes Meadow, Millboard Road, Bourne End, Buckinghamshire, SL8 5FH, U.K
Tel: +44-1628-585-100, Fax: +44-1628-585-900**Renesas Electronics Europe GmbH**Arcadiastrasse 10, 40472 Düsseldorf, Germany
Tel: +49-211-6503-0, Fax: +49-211-6503-1327**Renesas Electronics (China) Co., Ltd.**Room 1709, Quantum Plaza, No.27 ZhiChunLu Haidian District, Beijing 100191, P.R.China
Tel: +86-10-8235-1155, Fax: +86-10-8235-7679**Renesas Electronics (Shanghai) Co., Ltd.**Unit 301, Tower A, Central Towers, 555 Langao Road, Putuo District, Shanghai, P. R. China 200333
Tel: +86-21-2226-0888, Fax: +86-21-2226-0999**Renesas Electronics Hong Kong Limited**Unit 1601-1611, 16/F., Tower 2, Grand Century Place, 193 Prince Edward Road West, Mongkok, Kowloon, Hong Kong
Tel: +852-2265-6688, Fax: +852 2886-9022**Renesas Electronics Taiwan Co., Ltd.**13F, No. 363, Fu Shing North Road, Taipei 10543, Taiwan
Tel: +886-2-8175-9600, Fax: +886 2-8175-9670**Renesas Electronics Singapore Pte. Ltd.**80 Bendemeer Road, Unit #06-02 Hyflux Innovation Centre, Singapore 339949
Tel: +65-6213-0200, Fax: +65-6213-0300**Renesas Electronics Malaysia Sdn.Bhd.**Unit 1207, Block B, Menara Amcorp, Amcorp Trade Centre, No. 18, Jln Persiaran Barat, 46050 Petaling Jaya, Selangor Darul Ehsan, Malaysia
Tel: +60-3-7955-9390, Fax: +60-3-7955-9510**Renesas Electronics India Pvt. Ltd.**No.777C, 100 Feet Road, HAL II Stage, Indiranagar, Bangalore, India
Tel: +91-80-67208700, Fax: +91-80-67208777**Renesas Electronics Korea Co., Ltd.**12F., 234 Teheran-ro, Gangnam-Gu, Seoul, 135-080, Korea
Tel: +82-2-558-3737, Fax: +82-2-558-5141

Renesas Synergy™ Platform
Application Example for Capacitive Touch
(AE-CAP1)

