

REVISIONS			
REV.	DESCRIPTION	DATE	APPROVED
A	INITIAL RELEASE	10/28/09	A.D.M.

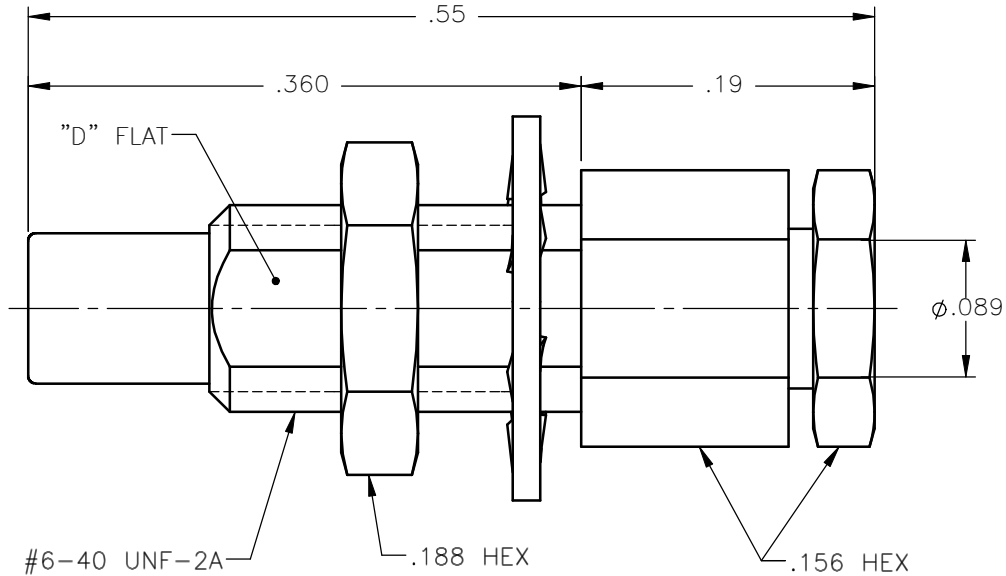
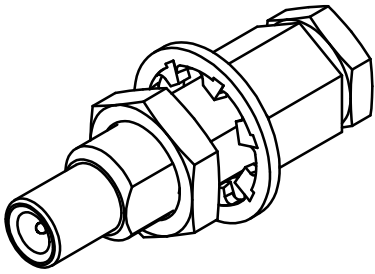

NOTES:

MATERIALS:

1. BODY & CONTACT = BERYLLIUM COPPER PER ASTM B196, ALLOY C17300, TEMPER TD04.
2. INSULATORS = VIRGIN WHITE TEFLON PER ASTM D1710, GRADE 1, TYPE I, CLASS "B".
3. BACK NUT & NUT = BRASS PER ASTM B16, ALLOY C36000, TEMPER H02.
4. LOCKWASHER = PHOSPHOR BRONZE PER ASTM B139, COPPER ALLOY C53400, TEMPER H04.

FINISHES:

1. CONTACT = GOLD PLATE PER MIL-G-45204, TYPE II, CLASS 1, GRADE C, OVER .00010 TO .00020 STRESS FREE SULFAMATE NICKEL PER QQ-N-290.
2. ALL OTHER METAL PARTS = GOLD PLATE PER MIL-G-45204, TYPE II, CLASS 0, GRADE C, OVER .00010 TO .00020 COPPER STRIKE PER MIL-C-14550.

Property of Radiall Incorporated
This document cannot be reproduced or communicated to a third party without prior written permission of RADIALL Incorporated.

UNLESS OTHERWISE SPECIFIED DIMENSIONS ARE IN INCHES TOLERANCES ON	DWN: A.D.M.	DATE: 10/28/09	 APPLIED ENGINEERING PRODUCTS 104 John W. Murphy Dr. New Haven, CT 06513 a RADIALL company		
	CHKD: D.N.	DATE: 10/28/09			
DECIMAL	ANGLE	APVD: J.M.	DATE: 10/28/09	SSMC STRAIGHT JACK BULKHEAD REAR MOUNT SOLDER CLAMP TYPE FOR .085 S/R & SIMILAR CABLES	
REFERENCE:	MATERIALS & FINISHES:	SEE NOTES			
ORIGINATED: A.D.M. DATE: 10/28/09		SIZE: A	FSCM NO.: 19505	DWG NO.: 7003-1542-010	REV: A
		SCALE: 8:1	THIRD ANGLE PROJECTION		SHEET 1 OF 1

7003-1542-010