

Features:

- Precision tolerances to $\pm 0.01\%$
- TCR down to $\pm 2 \text{ ppm}/^\circ\text{C}$
- Wide R-value range
- Lower values may be available
- Contact Stackpole for tighter tolerances
- Qualified to AEC-Q200
- 100% RoHS compliant and lead free without exemption
- Halogen free
- REACH compliant



Electrical Specifications – Precision Thin Film Chip Resistor											
Type/Code	Power Rating ⁽²⁾ (W) @ 70°C	Maximum Working Voltage (V) ⁽¹⁾	Maximum Overload Voltage (V)	TCR (ppm/°C)	Ohmic Range (Ω) and Tolerance						
					0.01%	0.05%	0.1%	0.25%	0.5%	1%	
RNCF0201	0.05	15	30	± 10	-		22 - 5K*				
				± 15			22 - 75K				
				± 25							
				± 50							
RNCF0402	0.063	50	100	± 10	12.1K - 20K		-				
				± 15			4.02 - 4.64, 261K - 511K				
				± 25			-				
				± 50			-				
	0.1	50	100	± 10	49.9 - 12K		49.9 - 100K				
				± 15			-				
				± 25			-	49.9 - 12K	4.7 - 255K		
				± 50			-				
RNCF0603	0.1	75	150	± 10	24.9 - 100K	4.7 - 332K	4.7 - 511K				
				± 15	24.9 - 100K	4.7 - 9.88	1 - 9.76, 336K - 1M				
				± 25	-		10 - 332K				
				± 50	-		-				
	0.166	100	150	± 25	-		10 - 332K				
				± 50	-		-				
				± 10	-	517K - 1M	-				
				± 15	-	505K - 1M	1.02M - 2M				
RNCF0805	0.125	150	300	± 10	24.9 - 200K	4.7 - 511K	4.7 - 1M				
				± 15	24.9 - 200K	4.7 - 9.88	505K - 1M				
				± 25	-		10 - 499K				
				± 50	-		-				
	0.25	150	300	± 25	-		10 - 499K				
				± 50	-		-				
				± 10	-		1.02M - 1.5M				
				± 15	-		1.02M - 2.5M				
RNCF1206	0.125	150	300	± 25	-		1.02M - 1.5M				
				± 50	-		1.02M - 2.5M				
				± 10	24.9 - 499K	4.7 - 1M					
				± 15	24.9 - 499K	1 - 9.76					
	0.25	200	400	± 25	-		10 - 1M				
				± 50	-		-				
				± 10	-		1.02M - 1.5M				
				± 15	-		1.02M - 2.5M				

* Subject to higher MOQ.

(1) Lesser of $\sqrt{P \cdot R}$ or maximum working voltage.

(2) For lower power ratings, contact Stackpole.

Electrical Specifications – Precision Thin Film Chip Resistor (cont.)

Type/Code	Power Rating ⁽²⁾ (W) @ 70°C	Maximum Working Voltage (V) ⁽¹⁾	Maximum Overload Voltage (V)	TCR (ppm/°C)	Ohmic Range (Ω) and Tolerance										
					0.01%	0.05%	0.1%	0.25%	0.5%	1%					
RNCF1210	0.25	150	300	± 25	-		1.02M - 2.5M								
				± 50											
	0.33	200	400	± 10	24.9 - 499K	4.7 - 1M									
				± 15	24.9 - 499K					1 - 1M					
			± 25												
			± 50												
RNCF2010	0.25	150	300	± 25	-		1.02M - 3M								
				± 50											
	0.33	200	400	± 10	24.9 - 499K	4.7 - 1M									
				± 15	24.9 - 499K					1 - 1M					
			± 25												
			± 50												
RNCF2512	0.5	150	300	± 10	2.05K - 499K		2.05K - 1M								
				± 15											
				± 25							-	2.05K - 1M	2.05K - 3M		
				± 50											
	0.75	200	400	± 10	24.9 - 2K	4.7 - 2K	4.7 - 2K	1 - 2K							
				± 15	24.9 - 2K	4.7 - 2K	101 - 2K			101 - 2K					
							± 25								
							± 50								
1	200	400	± 25	-		4.7 - 100		1 - 100							
			± 50												

(1) Lesser of $\sqrt{P \cdot R}$ or maximum working voltage.

(2) For lower power ratings, contact Stackpole.

Electrical Specifications – Ultra-Precision Thin Film Chip Resistor

Type/Code	Power Rating ⁽²⁾ (W) @ 70°C	Maximum Working Voltage (V) ⁽¹⁾	Maximum Overload Voltage (V)	TCR (ppm/°C)	Ohmic Range (Ω) and Tolerance					
					0.01%	0.05%	0.1%	0.25%	0.5%	1%
RNCF0402	0.1	50	100	± 2	49.9 - 4.99K		-			
				± 5	49.9 - 20K					
RNCF0603	0.1	75	150	± 2	24.9 - 15K		-			
				± 5	24.9 - 59K					
RNCF0805	0.125	150	300	± 2	24.9 - 30K		-			
				± 5	24.9 - 150K					
RNCF1206	0.25	200	400	± 2	24.9 - 49.9K		-			
				± 5	24.9 - 300K					
RNCF1210	0.33	200	400	± 2	24.9 - 49.9K		-			
				± 5	24.9 - 300K					
RNCF2010	0.25	150	300	± 2	51K - 100K		-			
				± 2	24.9 - 49.9K		-			
				± 5	24.9 - 300K					
RNCF2512	0.5	150	300	± 2	24.9 - 100K		-			
				± 5	24.9 - 300K					

(1) Lesser of $\sqrt{P \cdot R}$ or maximum working voltage.

(2) For lower power ratings, contact Stackpole.

Mechanical Specifications

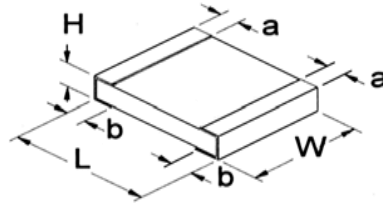

Type/Code	Weight (g) (1000 pc.)	L Body Length	W Body Width	H Body Height	a Top Termination	b Bottom Termination	Unit
RNCF0201	0.14	0.023 ± 0.003	0.011 ± 0.002	0.009 ± 0.002	0.005 ± 0.002	0.006 ± 0.002	inches
		0.58 ± 0.07	0.29 ± 0.06	0.23 ± 0.05	0.12 ± 0.05	0.15 ± 0.05	mm
RNCF0402	0.54	0.039 ± 0.002	0.020 ± 0.002	0.012 ± 0.002	0.008 ± 0.004	0.008 ± 0.004	inches
		1.00 ± 0.05	0.50 ± 0.05	0.30 ± 0.05	0.20 ± 0.10	0.20 ± 0.10	mm
RNCF0603	1.83	0.061 ± 0.004	0.031 ± 0.004	0.018 ± 0.004	0.012 ± 0.008	0.012 ± 0.008	inches
		1.55 ± 0.10	0.80 ± 0.10	0.45 ± 0.10	0.30 ± 0.20	0.30 ± 0.20	mm
RNCF0805	4.71	0.079 ± 0.006	0.049 ± 0.006	0.022 ± 0.004	0.012 ± 0.008	0.016 ± 0.008	inches
		2.00 ± 0.15	1.25 ± 0.15	0.55 ± 0.10	0.30 ± 0.20	0.40 ± 0.20	mm
RNCF1206	9.02	0.120 ± 0.006	0.061 ± 0.006	0.022 ± 0.004	0.017 ± 0.008	0.014 ± 0.010	inches
		3.05 ± 0.15	1.55 ± 0.15	0.55 ± 0.10	0.42 ± 0.20	0.35 ± 0.25	mm
RNCF1210	10	0.122 ± 0.006	0.094 ± 0.006	0.022 ± 0.004	0.016 ± 0.008	0.022 ± 0.010	inches
		3.10 ± 0.15	2.40 ± 0.15	0.55 ± 0.10	0.40 ± 0.20	0.55 ± 0.25	mm
RNCF2010	23.61	0.193 ± 0.006	0.094 ± 0.006	0.022 ± 0.004	0.024 ± 0.012	0.020 ± 0.010	inches
		4.90 ± 0.15	2.40 ± 0.15	0.55 ± 0.10	0.60 ± 0.30	0.50 ± 0.25	mm
RNCF2512	38.6	0.248 ± 0.006	0.122 ± 0.006	0.022 ± 0.004	0.024 ± 0.012	0.020 ± 0.010	inches
		6.30 ± 0.15	3.10 ± 0.15	0.55 ± 0.10	0.60 ± 0.30	0.50 ± 0.25	mm

Performance Characteristics

Test	Test Method	Test Specification		Test Condition
		Tol. ≤ 0.05%	Tol. > 0.05%	
Temperature coefficient of Resistance (T.C.R.)	MIL-STD-202 Method 304	As specified.		+25 / -55 / +25 / +125 / +25°C
Short Time Overload	JIS-C-5201-1 4.13	Δ R ± 0.05%	Δ R ± 0.2%	RCWV * 2.5 or Max. overload voltage whichever is lower for 5 seconds
Insulation Resistance	MIL-STD-202 Method 302	> 9999M Ω		
Endurance	MIL-STD-202 Method 108A	Δ R ± 0.05%	Δ R ± 0.2%	70 ± 2°C, RCWV for 1000 hours with 1.5 hours "ON" and 0.5 hour "OFF"
		Δ R ± 0.5% for high power rating		
		0201 ≤ 7K Ω: Δ R ± 0.2% 0201 > 7K Ω: Δ R ± 0.5%		
Damp Heat with Load	MIL-STD-202 Method 103B	Δ R ± 0.05%	Δ R ± 0.3%	40 ± 2°C, 90 ~ 95% R.H. RCWV for 1000 hours with 1.5 hours "ON" and 0.5 hour "OFF"
		Δ R ± 0.5% for high power rating		
Bending Strength	JIS-C-5201-1 4.33	Δ R ± 0.05%	Δ R ± 0.1%	Bending amplitude for 10 seconds. 2010 and 2512 sizes: 2 mm Other sizes: 3 mm
Solderability	MIL-STD-202 Method 208H	95% min. coverage		245 ± 5°C for 3 seconds
Resistance to Soldering Heat	MIL-STD-202 Method 210E	Δ R ± 0.05%	Δ R ± 0.1%	260 ± 5°C for 10 seconds
Dielectric Withstand Voltage	MIL-STD-202 Method 301	by type		Max. overload voltage for 1 minute
Low Temperature Operation	JIS-C-5201-1 4.36	Δ R ± 0.05%	Δ R ± 0.2%	1 hour, - 65°C, followed by 45 minutes of RCWV
		Δ R ± 0.5% for high power rating		
High Temperature Exposure	MIL-STD-202 Method 108	Δ R ± 0.5%		+155°C for 1000 hours

RCWV (Rated Continuous Working Voltage) = $\sqrt{P \cdot R}$ or Max. Operating Voltage, whichever is lower.

Storage Temperature: 60 ~ 82°F. Humidity < 80% R.H.

Operating temperature range is -55°C to + 155°C

Power Derating Curve:

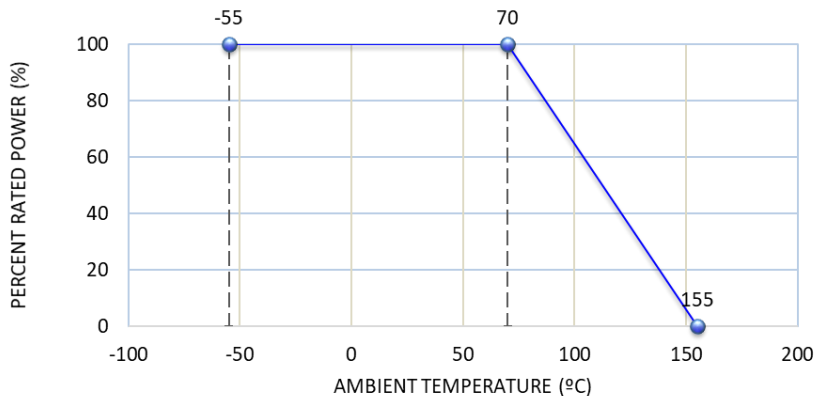

Soldering Condition:

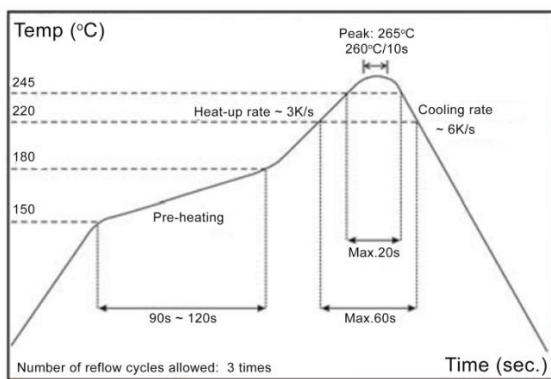

IR Reflow Soldering

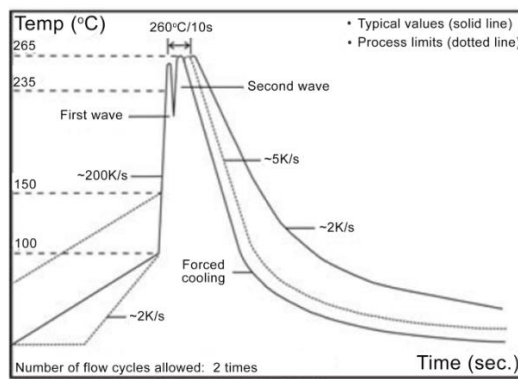

Wave Soldering (Flow Soldering)

- (1) Time of IR reflow soldering at maximum temperature point 260°C: 10 seconds
- (2) Time of wave soldering at maximum temperature point 260°C: 10 seconds
- (3) Time of soldering iron at maximum temperature point 410°C: 5 seconds

Reel Specifications

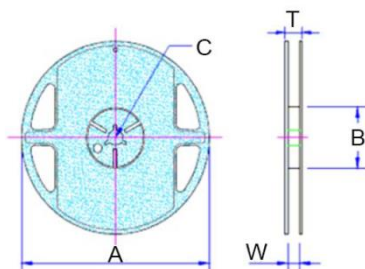

Type/Code	A	B	C	W	T	Unit
RNCF0201	7.008 ± 0.039	2.362 ± 0.039	0.531 ± 0.028	0.374 ± 0.039	0.453 ± 0.039	inches
	178.00 ± 1.00	60.00 ± 1.00	13.50 ± 0.70	9.50 ± 1.00	11.50 ± 1.00	mm
RNCF0402	7.008 ± 0.039	2.362 ± 0.039	0.531 ± 0.028	0.374 ± 0.039	0.453 ± 0.039	inches
	178.00 ± 1.00	60.00 ± 1.00	13.50 ± 0.70	9.50 ± 1.00	11.50 ± 1.00	mm
RNCF0603	7.008 ± 0.039	2.362 ± 0.039	0.531 ± 0.028	0.374 ± 0.039	0.453 ± 0.039	inches
	178.00 ± 1.00	60.00 ± 1.00	13.50 ± 0.70	9.50 ± 1.00	11.50 ± 1.00	mm
RNCF0805	7.008 ± 0.039	2.362 ± 0.039	0.531 ± 0.028	0.374 ± 0.039	0.453 ± 0.039	inches
	178.00 ± 1.00	60.00 ± 1.00	13.50 ± 0.70	9.50 ± 1.00	11.50 ± 1.00	mm

Reel Specifications (cont.)						
Type/Code	A	B	C	W	T	Unit
RNCF1206	7.008 ± 0.039	2.362 ± 0.039	0.531 ± 0.028	0.374 ± 0.039	0.453 ± 0.039	inches
	178.00 ± 1.00	60.00 ± 1.00	13.50 ± 0.70	9.50 ± 1.00	11.50 ± 1.00	mm
RNCF1210	7.008 ± 0.039	2.362 ± 0.039	0.531 ± 0.028	0.374 ± 0.039	0.453 ± 0.039	inches
	178.00 ± 1.00	60.00 ± 1.00	13.50 ± 0.70	9.50 ± 1.00	11.50 ± 1.00	mm
RNCF2010	7.008 ± 0.039	2.362 ± 0.039	0.531 ± 0.028	0.531 ± 0.039	0.610 ± 0.039	inches
	178.00 ± 1.00	60.00 ± 1.00	13.50 ± 0.70	13.50 ± 1.00	15.50 ± 1.00	mm
RNCF2512	7.008 ± 0.039	2.362 ± 0.039	0.531 ± 0.028	0.531 ± 0.039	0.610 ± 0.039	inches
	178.00 ± 1.00	60.00 ± 1.00	13.50 ± 0.70	13.50 ± 1.00	15.50 ± 1.00	mm

Packaging Specifications – Paper Tape

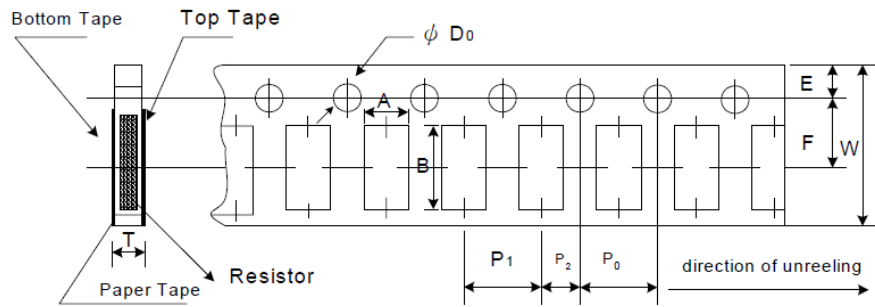

Type/Code	A	B	W	E	F	Unit
RNCF0201	0.016 ± 0.002	0.028 ± 0.002	0.315 ± 0.004	0.069 ± 0.002	0.138 ± 0.002	inches
	0.40 ± 0.05	0.70 ± 0.05	8.00 ± 0.10	1.75 ± 0.05	3.50 ± 0.05	mm
RNCF0402	0.028 ± 0.002	0.046 ± 0.002	0.315 ± 0.004	0.069 ± 0.002	0.138 ± 0.002	inches
	0.70 ± 0.05	1.16 ± 0.05	8.00 ± 0.10	1.75 ± 0.05	3.50 ± 0.05	mm
RNCF0603	0.043 ± 0.002	0.075 ± 0.002	0.315 ± 0.004	0.069 ± 0.002	0.138 ± 0.002	inches
	1.10 ± 0.05	1.90 ± 0.05	8.00 ± 0.10	1.75 ± 0.05	3.50 ± 0.05	mm
RNCF0805	0.063 ± 0.002	0.093 ± 0.002	0.315 ± 0.004	0.069 ± 0.020	0.138 ± 0.002	inches
	1.60 ± 0.05	2.37 ± 0.05	8.00 ± 0.10	1.75 ± 0.50	3.50 ± 0.05	mm
RNCF1206	0.079 ± 0.002	0.140 ± 0.002	0.315 ± 0.004	0.069 ± 0.002	0.138 ± 0.002	inches
	2.00 ± 0.05	3.55 ± 0.05	8.00 ± 0.10	1.75 ± 0.05	3.50 ± 0.05	mm
RNCF1210	0.108 ± 0.002	0.134 ± 0.002	0.315 ± 0.004	0.069 ± 0.002	0.138 ± 0.002	inches
	2.75 ± 0.05	3.40 ± 0.05	8.00 ± 0.10	1.75 ± 0.05	3.50 ± 0.05	mm
Type/Code	P0	P1	P2	D0	T	Unit
RNCF0201	0.157 ± 0.004	0.079 ± 0.002	0.079 ± 0.002	0.061 ± 0.001	0.017 ± 0.001	inches
	4.00 ± 0.10	2.00 ± 0.05	2.00 ± 0.05	1.55 ± 0.03	0.42 ± 0.02	mm
RNCF0402	0.157 ± 0.004	0.079 ± 0.002	0.079 ± 0.002	0.061 ± 0.002	0.016 ± 0.001	inches
	4.00 ± 0.10	2.00 ± 0.05	2.00 ± 0.05	1.55 ± 0.05	0.40 ± 0.03	mm
RNCF0603	0.157 ± 0.004	0.157 ± 0.004	0.079 ± 0.002	0.061 ± 0.002	0.024 ± 0.001	inches
	4.00 ± 0.10	4.00 ± 0.10	2.00 ± 0.05	1.55 ± 0.05	0.60 ± 0.03	mm
RNCF0805	0.157 ± 0.004	0.157 ± 0.004	0.079 ± 0.002	0.061 ± 0.002	0.030 ± 0.002	inches
	4.00 ± 0.10	4.00 ± 0.10	2.00 ± 0.05	1.55 ± 0.05	0.75 ± 0.05	mm
RNCF1206	0.157 ± 0.004	0.157 ± 0.004	0.079 ± 0.002	0.061 ± 0.002	0.030 ± 0.002	inches
	4.00 ± 0.10	4.00 ± 0.10	2.00 ± 0.05	1.55 ± 0.05	0.75 ± 0.05	mm
RNCF1210	0.157 ± 0.002	0.157 ± 0.004	0.079 ± 0.002	0.063 ± 0.004	0.030 ± 0.002	inches
	4.00 ± 0.05	4.00 ± 0.10	2.00 ± 0.05	1.60 ± 0.10	0.75 ± 0.05	mm

Peel Force of Top Cover Tape

The peel speed shall be about 300 mm / min \pm 5%
The peel force of top cover tape shall be between 8gf to 60gf

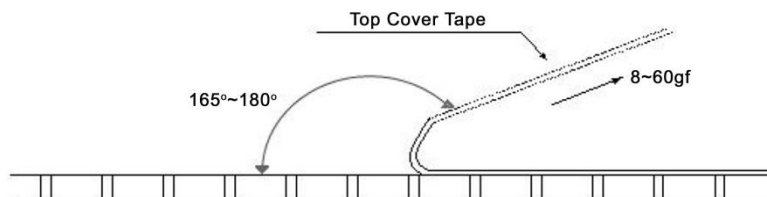

Packaging Specifications – Embossed Plastic Tape

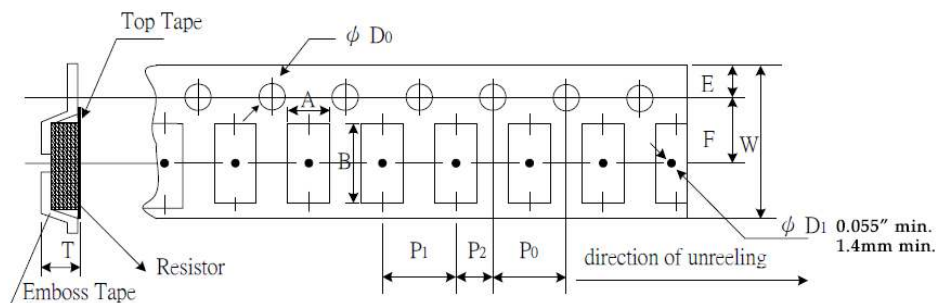

Type/Code	A	B	W	E	F	Unit
RNCF2010	0.112 \pm 0.004	0.215 \pm 0.004	0.472 \pm 0.004	0.069 \pm 0.004	0.217 \pm 0.002	inches
	2.85 \pm 0.10	5.45 \pm 0.10	12.00 \pm 0.10	1.75 \pm 0.10	5.50 \pm 0.05	mm
RNCF2512	0.134 \pm 0.004	0.262 \pm 0.004	0.472 \pm 0.004	0.069 \pm 0.004	0.217 \pm 0.002	inches
	3.40 \pm 0.10	6.65 \pm 0.10	12.00 \pm 0.10	1.75 \pm 0.10	5.50 \pm 0.05	mm
Type/Code	P0	P1	P2	D0	T	Unit
RNCF2010	0.157 \pm 0.002	0.157 \pm 0.004	0.079 \pm 0.002	0.059 \pm 0.004	0.039 \pm 0.008	inches
	4.00 \pm 0.05	4.00 \pm 0.10	2.00 \pm 0.05	1.50 \pm 0.10	1.00 \pm 0.20	mm
RNCF2512	0.157 \pm 0.002	0.157 \pm 0.004	0.079 \pm 0.002	0.059 \pm 0.004	0.039 \pm 0.008	inches
	4.00 \pm 0.05	4.00 \pm 0.10	2.00 \pm 0.05	1.50 \pm 0.10	1.00 \pm 0.20	mm

Peel Force of Top Cover Tape

The peel speed shall be about 300 mm / min \pm 5%
The peel force of top cover tape shall be between 20gf to 80gf

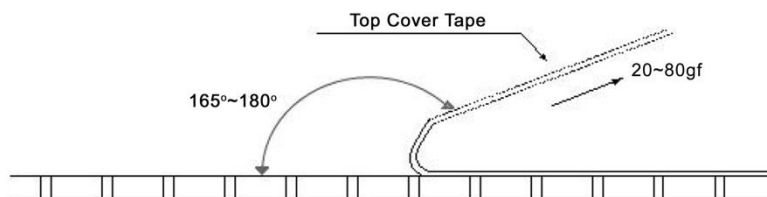

Recommended Pad Layout

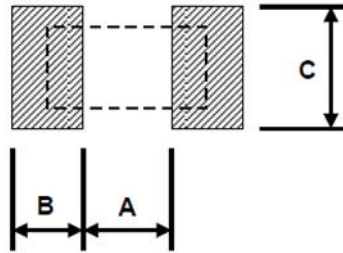

Type/Code	A	B	C	Unit
RNCF0201	0.010	0.012	0.016 ± 0.008	inches
	0.25	0.30	0.40 ± 0.20	mm
RNCF0402	0.020	0.020	0.024 ± 0.008	inches
	0.50	0.50	0.60 ± 0.20	mm
RNCF0603	0.031	0.039	0.035 ± 0.008	inches
	0.80	1.00	0.90 ± 0.20	mm
RNCF0805	0.039	0.039	0.053 ± 0.008	inches
	1.00	1.00	1.35 ± 0.20	mm
RNCF1206	0.079	0.045	0.067 ± 0.008	inches
	2.00	1.15	1.70 ± 0.20	mm
RNCF1210	0.079	0.045	0.098 ± 0.008	inches
	2.00	1.15	2.50 ± 0.20	mm
RNCF2010	0.142	0.055	0.098 ± 0.008	inches
	3.60	1.40	2.50 ± 0.20	mm
RNCF2512	0.193	0.063	0.122 ± 0.008	inches
	4.90	1.60	3.10 ± 0.20	mm

RoHS Compliance

Stackpole Electronics has joined the worldwide effort to reduce the amount of lead in electronic components and to meet the various regulatory requirements now prevalent, such as the European Union’s directive regarding “Restrictions on Hazardous Substances” (RoHS 3). As part of this ongoing program, we periodically update this document with the status regarding the availability of our compliant components. All our standard part numbers are compliant to EU Directive 2011/65/EU of the European Parliament as amended by Directive (EU) 2015/863/EU as regards the list of restricted substances.

RoHS Compliance Status

Standard Product Series	Description	Package / Termination Type	Standard Series RoHS Compliant	Lead-Free Termination Composition	Lead-Free Mfg. Effective Date (Std Product Series)	Lead-Free Effective Date Code (YY/WW)
RNCF	Precision Thin Film Surface Mount Chip Resistor	SMD	YES	100% Matte Sn over Ni	May-04	04/18

“Conflict Metals” Commitment

We at Stackpole Electronics, Inc. are joined with our industry in opposing the use of metals mined in the “conflict region” of the eastern Democratic Republic of the Congo (DRC) in our products. Recognizing that the supply chain for metals used in the electronics industry is very complex, we work closely with our own suppliers to verify to the extent possible that the materials and products we supply do not contain metals sourced from this conflict region. As such, we are in compliance with the requirements of Dodd-Frank Act regarding Conflict Minerals.

Compliance to “REACH”

We certify that all passive components supplied by Stackpole Electronics, Inc. are SVHC (Substances of Very High Concern) free and compliant with the requirements of EU Directive 1907/2006/EC, “The Registration, Evaluation, Authorization and Restriction of Chemicals”, otherwise referred to as REACH. Contact us for complete list of REACH Substance Candidate List.

Environmental Policy

It is the policy of Stackpole Electronics, Inc. (SEI) to protect the environment in all localities in which we operate. We continually strive to improve our effect on the environment. We observe all applicable laws and regulations regarding the protection of our environment and all requests related to the environment to which we have agreed. We are committed to the prevention of all forms of pollution.

How to Order

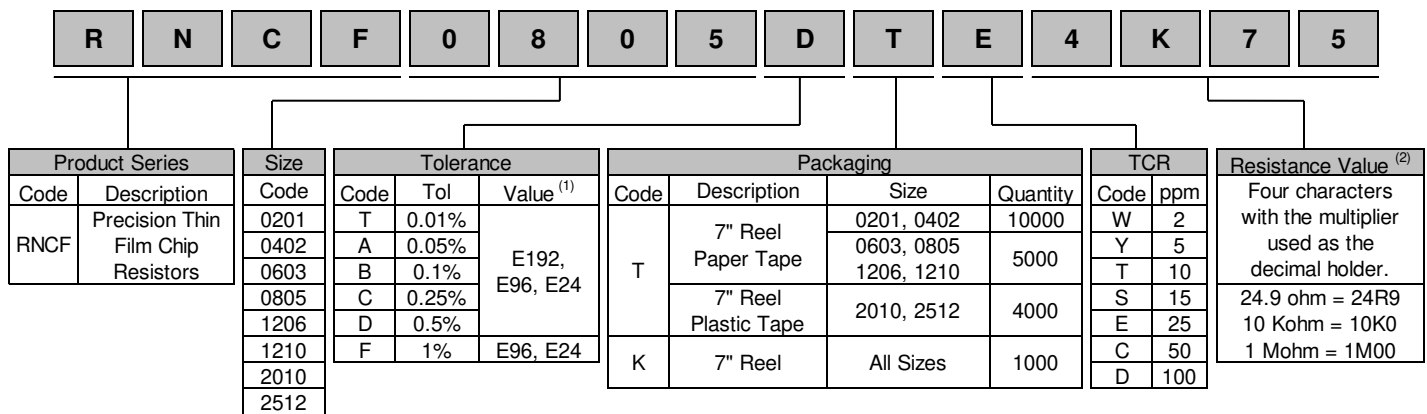

(1) E192 values are not marked, and may be subject to higher MOQ
 (2) Values below 10 ohm and above 1 Mohm may be subject to higher MOQ