

Enpirion EP5348UI 400mA Synchronous DC/DC Converter Module Evaluation Board

Introduction

Thank you for choosing Altera Enpirion power products!

You are evaluating a new class of DCDC converter product, a complete power system on silicon. This user guide is applicable to evaluation boards part number 05194 Rev A on the PCB back side. In addition to this document, you will also need the latest device datasheet.

- The EP5348UI is a complete module with integrated magnetics.
- The evaluation board is designed to offer a wide range of engineering evaluation capabilities.
- Output voltage is programmed using a resistor divider. The board comes populated with four pre-placed resistors and a jumper to choose one of four preset output voltages.
- Easy jumpers are provided for the following signals:
 - Enable
 - VOUT selection
- Numerous test points are provided as well as clip leads for input and output connections
- The board comes with input decoupling and input reverse polarity protection to protect the device from common setup mishaps.

Quick Start Guide

Figure 1 shows a top view of the evaluation board.

STEP 1: Set the “ENABLE” jumper J1 to the Disable Position, as shown here.

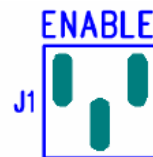

STEP 2: Set the output voltage by setting jumper J4 to one of the pre selected output voltage settings. See the Output Voltage Select section.

STEP 3: Connect Power Supply to the input clip leads, VIN (+) and GND (-).

CAUTION: Even though the evaluation board comes with reverse polarity protection diodes, be mindful of the polarity.

STEP 4: Connect the load to the output clip leads VOUT (+) and GND (-).

STEP 5: Power up the board and move the ENABLE jumper to the enabled position. The EP5348UI is now powered up.

Please note jumper J5 is not to be used on this board, and it has been left unpopulated. LLM is not offered on this product.

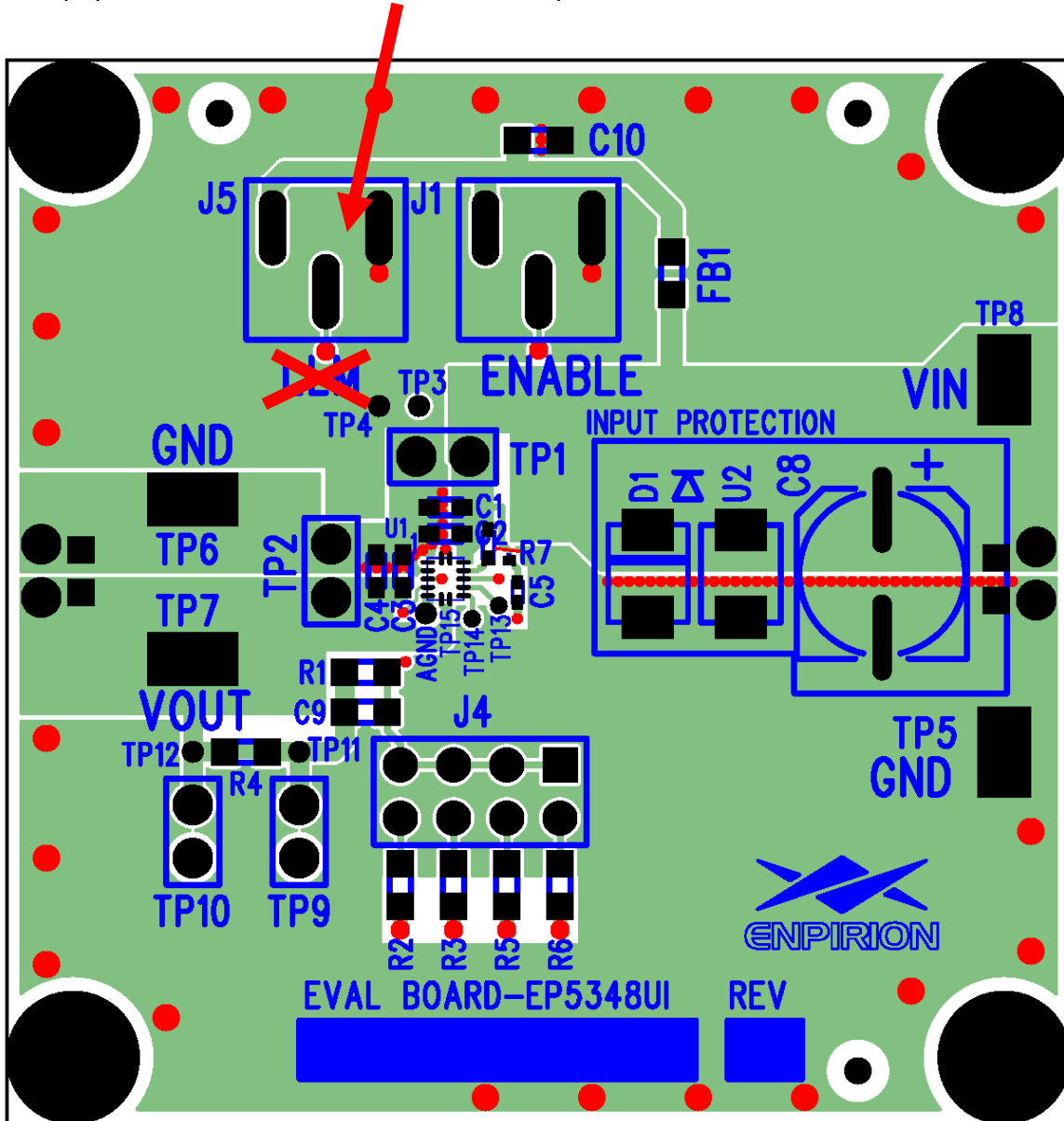

Figure 1. Evaluation Board Layout.

Output Voltage Select

The output voltage of the EP5348UI is programmed using a simple resistor divider. The evaluation board comes pre-populated with a set of four jumpers that allow the user to choose one of four preset voltages. Refer to Figure 2 for the specific settings. If no jumper is populated the default voltage setting will be 0.6V.

Higher output voltages can be programmed by populating multiple J4 jumper positions. It is also possible to remove one of the preset resistors and replace with another value to generate any desired output within the devices operating range.

Refer to the product data sheet for further information on setting the output voltage.

CAUTION: None of the J4 jumpers can be changed while the device is enabled. Doing so could damage the part.

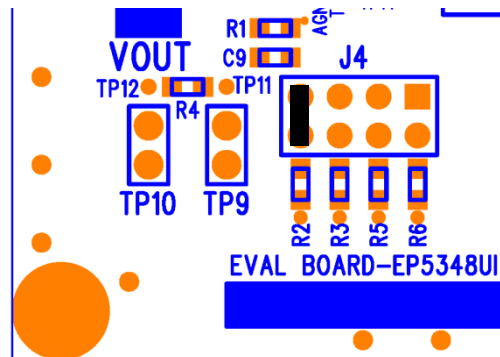

Figure 2. Close up of the V_{OUT} setting jumpers, J4. The nominal output voltage settings, from left to right are: 1.0V, 1.2V, 1.80V, and 2.5V. Jumper as shown here selects 1.0V. All voltages are subject to V_{OUT} tolerances.

Figure 4 shows the resistor values that make up the voltages mentioned above. Multiple jumpers can be populated to achieve other output voltages. Any of the resistors R2, R3, R5, or R6 can also be changed to modify the corresponding V_{OUT} setting. **Do not change R1. This value has been selected as part of the control loop compensation circuit.**

Test Recommendations

To guarantee measurement accuracy, the following precautions should be observed:

1. Make all input and output voltage measurements at the board using the test points provided. This will eliminate voltage drop across the line and load cables that can produce false readings.
2. Measure input and output current with series ammeters or accurate shunt resistors. This is especially important when measuring efficiency.
3. Use a low loop inductance scope probe across C_{OUT} to measure V_{OUT} Ripple to avoid noise coupling into the probe ground lead. The recommended probe configuration is shown in Figure 3.

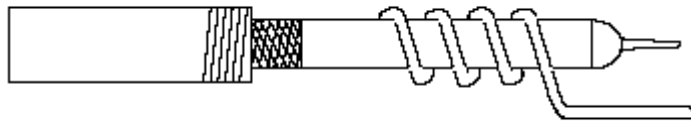

Figure 3. Recommended probe configuration.

4. The board has soldermask openings for 0805 ceramic capacitors at the input and output edges. If you are planning to do any radiated EMI testing on this board, place a 10uF, 0805, X7R or X5R capacitor at each board edge. The added capacitor at the input edge is for high-frequency decoupling of the input cables. The added capacitor at the output edge is meant to represent a typical load decoupling capacitor. Please contact Altera Power Applications support for further details regarding radiated EMI testing.

Input and Output Capacitors

The **input** capacitance on the board is a 2.2uF 0603 MLCC. There is a pre-tinned pad that allows for an additional 0603 case size MLCC to experiment with input filter performance.

The **output** capacitance on the board is a 10uF 0603 in parallel with a 1uF 0402.

NOTE: Capacitors must be X5R or X7R dielectric formulations.

Evaluation Board Schematic

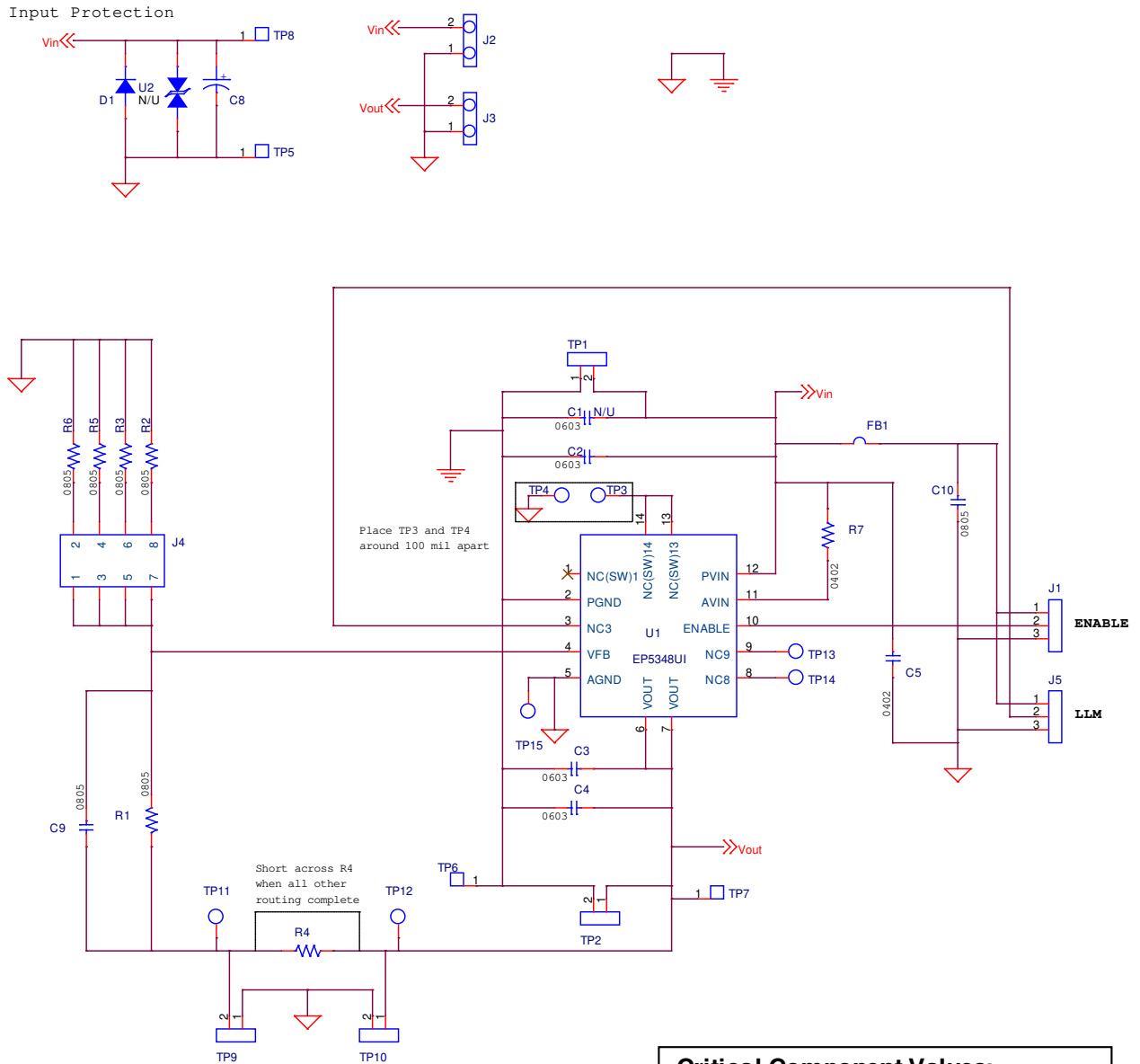

Figure 4. Evaluation Board Schematic and critical component values.

Critical Component Values:

- R1 = 100k
- R2 = 150k for 1.0V_{OUT}
- R3 = 100k for 1.2V_{OUT}
- R5 = 49.9k for 1.8V_{OUT}
- R6 = 31.6k for 2.5V_{OUT}
- C9 = 10pF
- C2 = 2.2uF X5R 0603
- C3 = 10uf X5R 0603
- C4 = 1uF X5R 0402



Contact Information

Altera Corporation
101 Innovation Drive
San Jose, CA 95134
Phone: 408-544-7000
www.altera.com/

© 2013 Altera Corporation—Confidential. All rights reserved. ALTERA, ARRIA, CYCLONE, ENPIRION, HARDCOPY, MAX, MEGACORE, NIOS, QUARTUS and STRATIX words and logos are trademarks of Altera Corporation and registered in the U.S. Patent and Trademark Office and in other countries. All other words and logos identified as trademarks or service marks are the property of their respective holders as described at www.altera.com/common/legal.html. Altera warrants performance of its semiconductor products to current specifications in accordance with Altera's standard warranty, but reserves the right to make changes to any products and services at any time without notice. Altera assumes no responsibility or liability arising out of the application or use of any information, product, or service described herein except as expressly agreed to in writing by Altera. Altera customers are advised to obtain the latest version of device specifications before relying on any published information and before placing orders for products or services.