

REVISIONS					
P	LTR	DESCRIPTION	DATE	DRN	APVD
C		REVISED PER ECN-23-223304	07AUG2023	GSK	MD

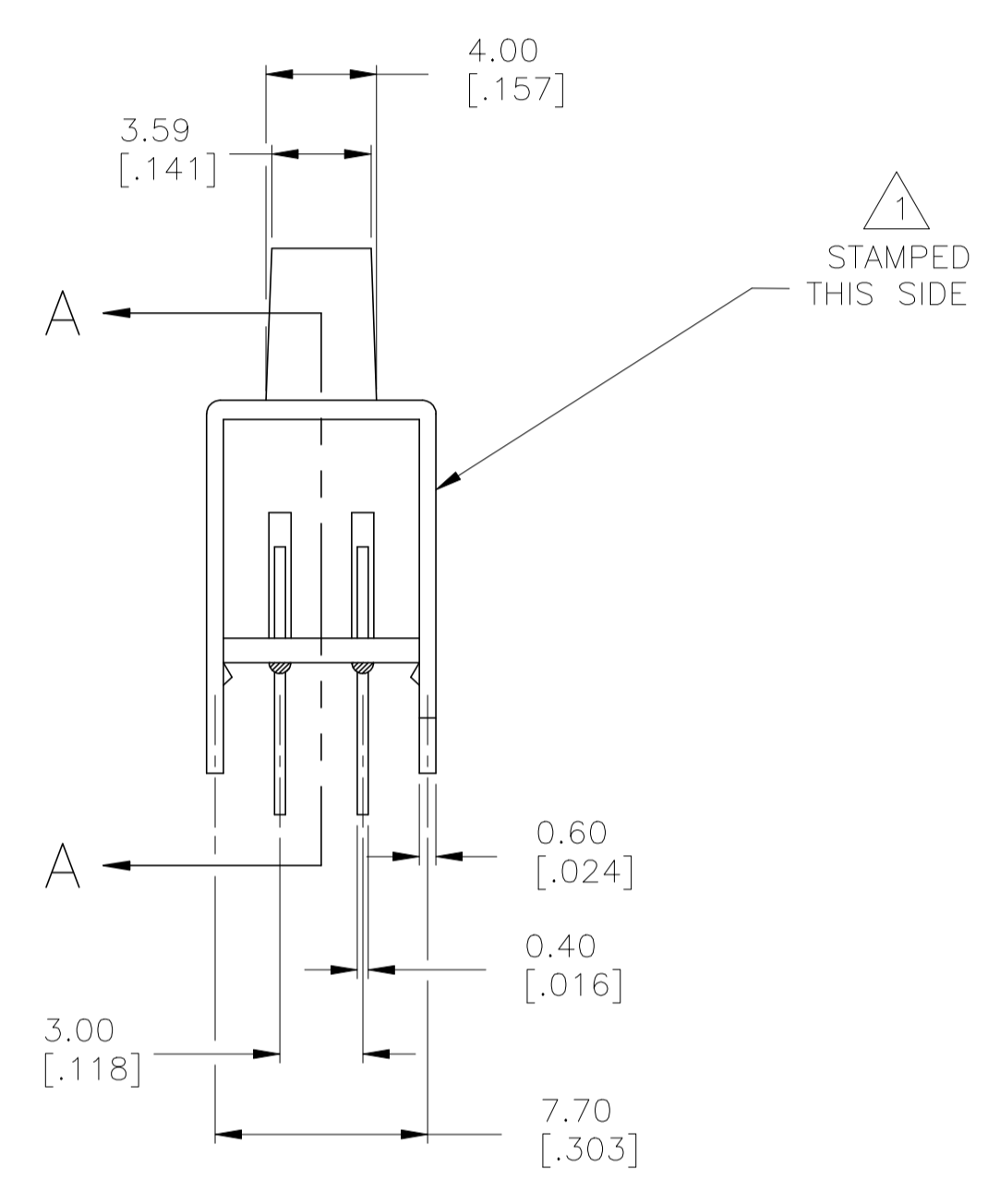
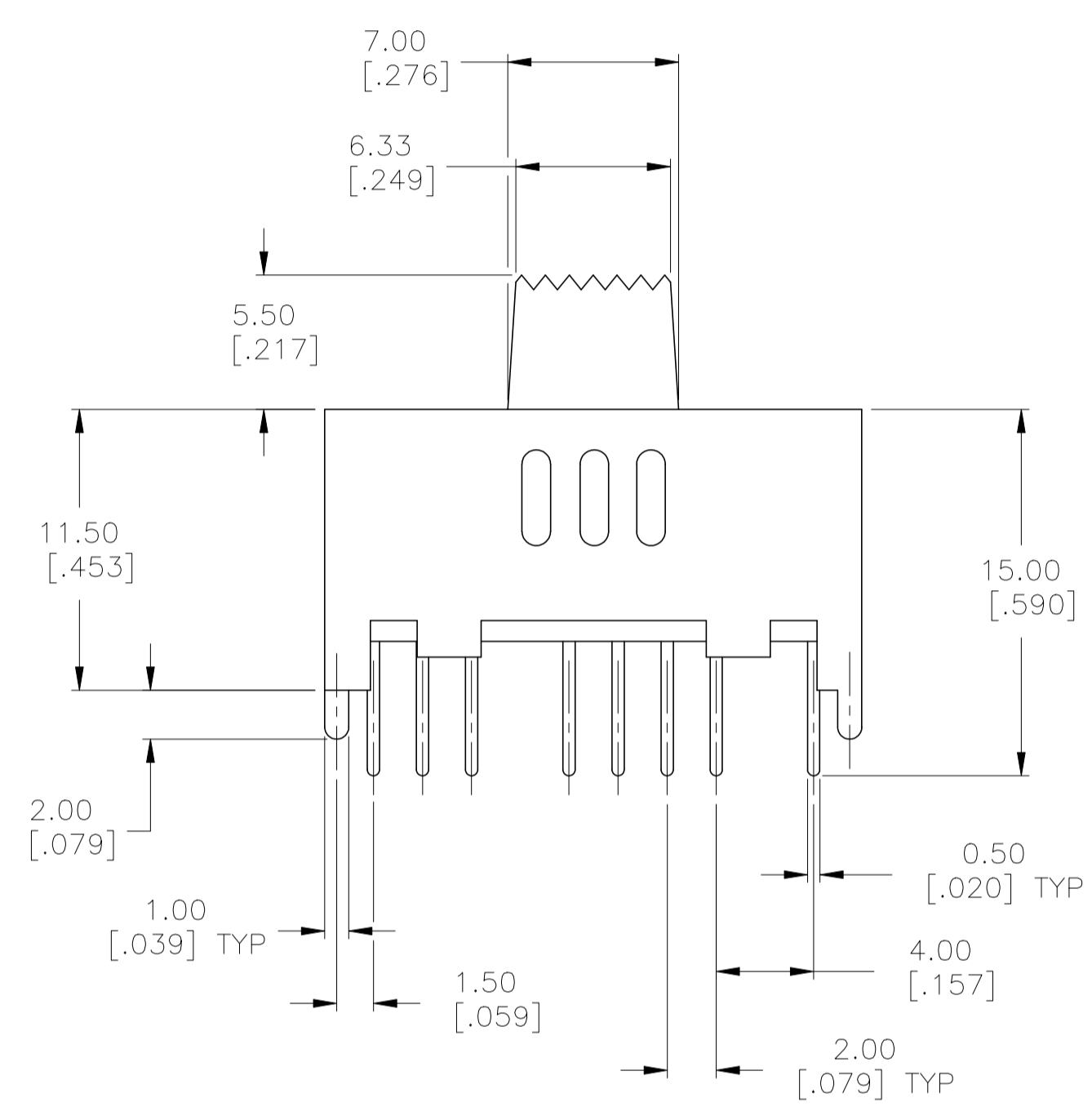
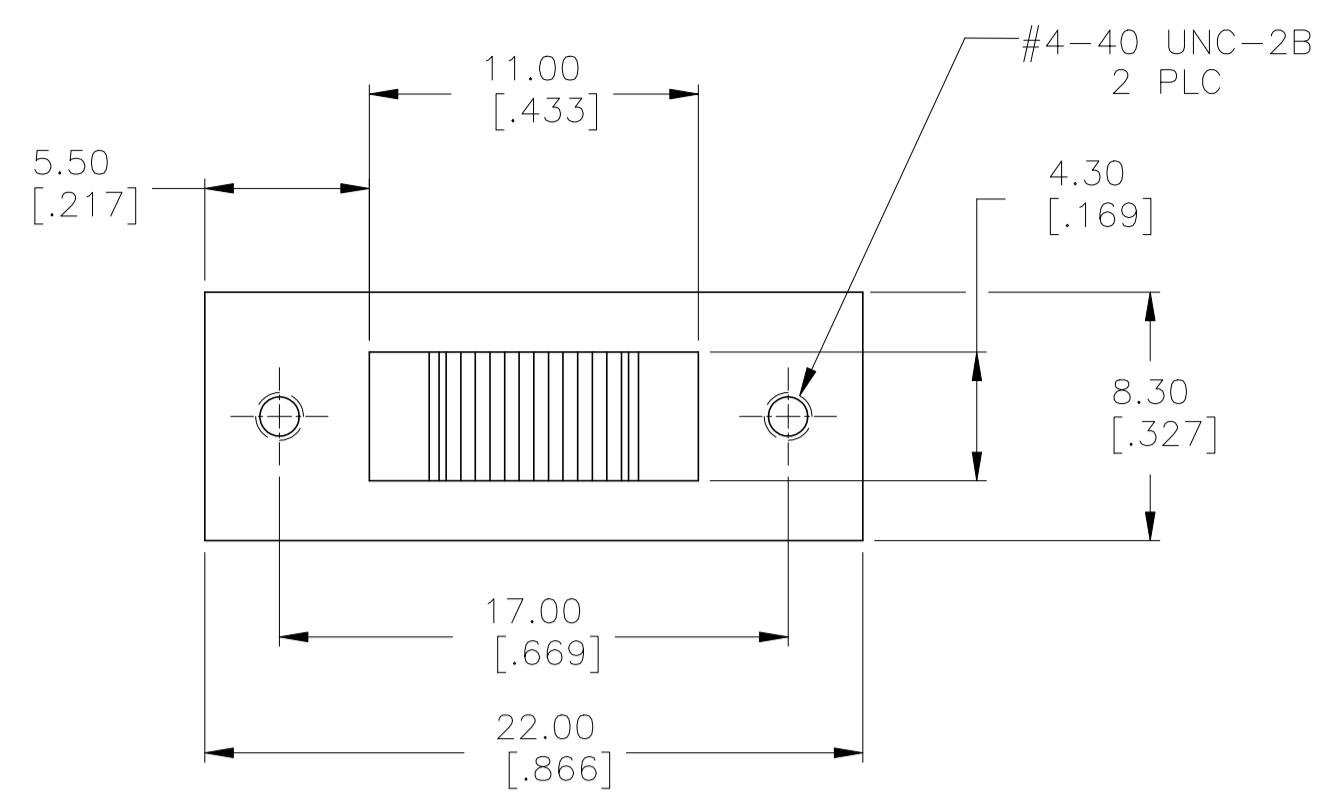

SPECIFICATIONS
MAKE-BEFORE-BREAK

MATERIALS:
ACTUATOR- POM, UL94HB BLACK
TERMINAL BOARD- PHENOLIC LAMINATED SHEET, UL94HB, NATURAL
FRAME- STEEL, NICKEL PLATE
TERMINAL/FIXED CONTACT- COPPER ALLOY, GOLD OR SILVER OVER NICKEL PLATE
MOVING CONTACT- COPPER ALLOY, GOLD OR SILVER OVER NICKEL PLATE
DETENT BALL- STEEL
COIL SPRING- GALVANIZED SPRING WIRE
SEAL- EPOXY

ELECTRICAL:
CONTACT RATING- .4VA@20VDC OR PEAK AC (GOLD); 300mA@125V AC (SILVER)
INITIAL CONTACT RESISTANCE- 30 milliohm max.
FINAL CONTACT RESISTANCE- 100 milliohm max. (AFTER TEST)
INSULATION RESISTANCE- 1,000 Megohms min.
DIELECTRIC STRENGTH- 500V RMS@SEA LEVEL
LIFE EXPECTANCY- 15,000 CYCLES MIN.

MECHANICAL:
ACTUATION FORCE- 600+/-300 GRAMS
TRAVEL- 2.0 +/-0.50 (.079 +/-0.020)

ENVIRONMENTAL:
OPERATING TEMPERATURE- -20 TO +85 DEGREES C
STORAGE TEMPERATURE- -40 TO +100 DEGREES C
RESISTANCE TO SOLDER HEAT PER 109-202, CONDITION B
SOLDERABILITY PER EIA-364-52, CLASS 2, CATEGORY 1, 95% MIN COVERAGE

NOTES:

- 1 COUNTRY OF ORIGIN AND TE CONNECTIVITY LOGO LOCATED APPROXIMATELY AS SHOWN
- 2 ALL MATERIALS AND FINISHES SHALL COMPLY WITH EU DIRECTIVE 2002/95/EC OF 27JAN2003 (ROHS).
- 3 ANTI SOLDER WICK SEAL AT TERMINAL TO BOARD INTERFACE.
- 4 ALL PERFORMANCE TESTING WAS DONE IN ACCORDANCE TO TE CONNECTIVITY SPECIFICATION 102-2469.

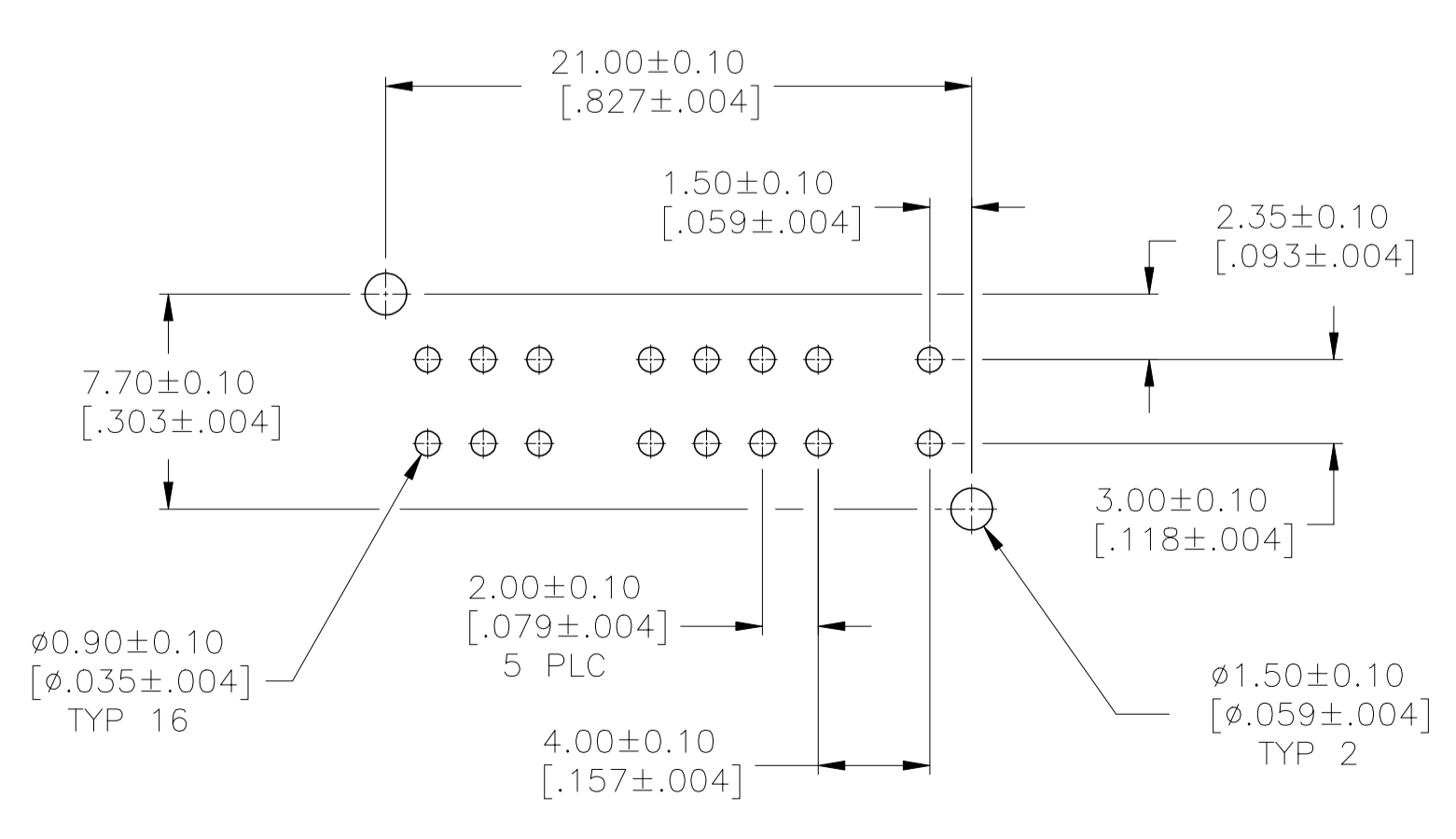
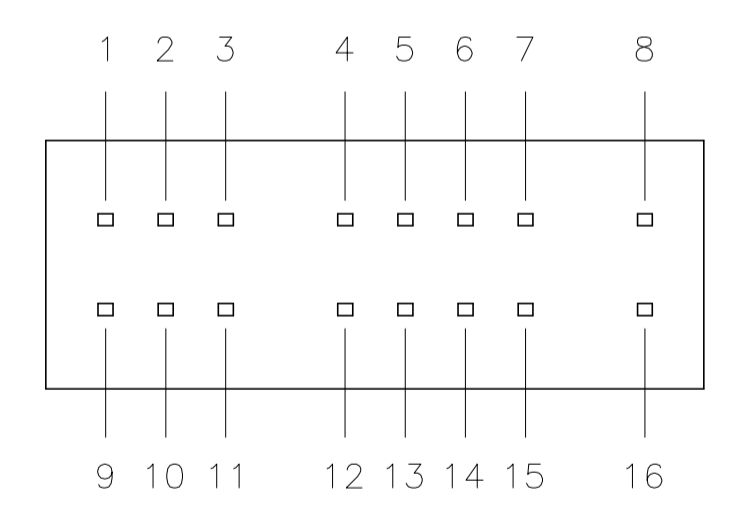

RECOMMENDED BOARD LAYOUT

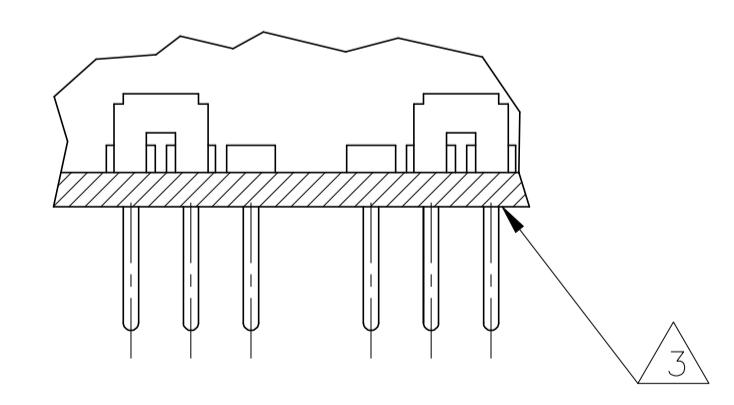

SECTION A-A

OBSELETE	1825267-2	MSS4300G04	GOLD	1 TO 3 5 TO 7 9 TO 11 13 TO 15	2 TO 3 6 TO 7 10 TO 11 14 TO 15	3 TO 4 7 TO 8 11 TO 12 15 TO 16
	1825267-1	MSS430004	SILVER	1 TO 3 5 TO 7 9 TO 11 13 TO 15	2 TO 3 6 TO 7 10 TO 11 14 TO 15	3 TO 4 7 TO 8 11 TO 12 15 TO 16
PART NO.	T&B PART NO.	PLATING				

TERMINALS CONNECTED WHEN SLIDE IS IN POSITION SHOWN.

THIS DRAWING IS A CONTROLLED DOCUMENT.		DRN	R	BROWN	21DEC05	STE		TE Connectivity	
DIMENSIONS:		DRW	M	SARVER	21DEC05	NAME		SLIDE SWITCH, MSS 4300 SERIES	
TOLERANCES UNLESS OTHERWISE SPECIFIED:		APVD	M	SARVER	21DEC05	PRODUCT SPEC		-	
0 PLC ± -		APPLICATION SPEC		-		SIZE		CAGE CODE	
1 PLC ± -		WEIGHT		-		DRAWING NO		RESTRICTED TO	
2 PLC ± 0.3[.012]		CUSTOMER DRAWING		-		A1 00779		1825267	
3 PLC ± -		SCALE		4:1		SHEET		1 OF 1	
4 PLC ± -		REV		C		REV		-	
ANGLES ± -		SCALE		4:1		SHEET		1 OF 1	
FINISH SEE SPECIFICATIONS		SCALE		4:1		SHEET		1 OF 1	