

REV.	DATE	ECR NO	DESCRIPTION
A	--	--	RELEASE TO MFG.
B	01/10/04	--	UPDATE DRAWING FORMAT/ MODIFY MOUNTING POSTS
C	02/25/10	2012	HARDWARES REMOVED

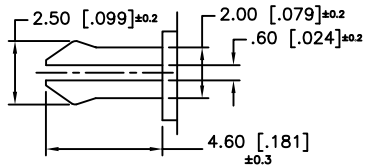

DETAIL -A-
(2X SCALE)

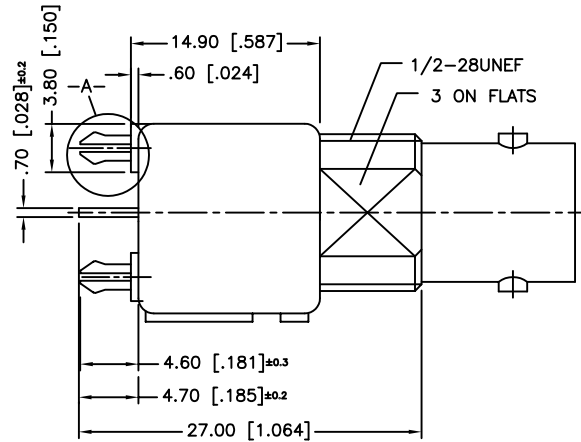
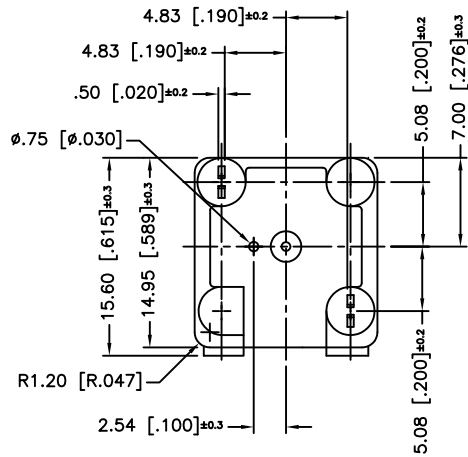
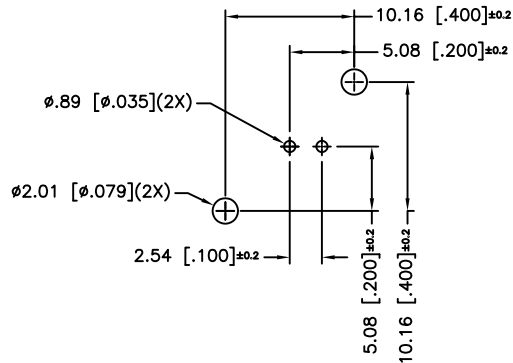

PCB MOUNTING HOLES

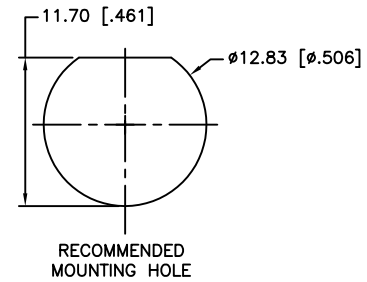

NOTE:
1. MAX. PANEL THICKNESS = 5mm

DESCRIPTION	MATERIAL	FINISH	QTY
5 MOUNTING POST	BRASS	TIN PLATING	
4 POST	COPPER	TIN PLATING	
3 CONTACT PIN	PHOS. BRONZE	GOLD	
2 INSULATOR	POLY PRO.	NATURAL	
1 BODY	ZINC DIE CAST	NICKEL	

UNLESS OTHERWISE SPECIFIED DIMENSIONS ARE IN MILLIMETERS. DIMENSIONS IN [] ARE IN INCHES AND FOR CUSTOMER REFERENCE ONLY.

UNLESS OTHERWISE SPECIFIED TOLERANCES FOR MILLIMETERS ARE:
0.5 - 8mm ± 0.20mm
8 - 30mm ± 0.40mm
30 - 120mm ± 0.50mm

UNLESS OTHERWISE SPECIFIED TOLERANCES FOR INCHES ARE:
.020 - .315 ± 0.007"
.315 - 1.180 ± 0.015"
1.180 - 4.724 ± 0.020"

DO NOT SCALE DRAWING

APPROVALS	DATE
DRAWN CLEMENT	02/25/10
CHECKED	
ISSUED	
SHEET 1 OF 1	
CAD FILE C:/112/112495.DWG	

Amphenol Connex			
PART DESCRIPTION			
BNC STRAIGHT PC MOUNT RECEPT. JACK			
PART NO.			
112495			
DWG. NO.	112495.DWG	REV. C	SCALE NA