

	AP1037
Stepper Motor Driver IC equipped with Active Decay Control	

1. General Description

The AP1037 is driver for bipolar stepper motors. It supports 35V motor power supply and 1.5A constant current operation. The AP1037 can automatically control Decay setting (slow, fast, pre-fast) in the IC inside by AKM original "Active Decay Control". The AP1037 can achieve optimal current setting, therefore will reduce current ripple and bring the motor rotation operation of the high efficiency. The input interface is clock-in method and supports from 2 Phase (full step) to 2W1-2 Phase (1/8step) excitation. In addition, the AP1037 is built-in a regulator for control circuit and capable of driving a motor only by motor power supply voltage (VM), therefore can facilitate design for the application.

It is housed in a small QFN package with good heat dissipation performance, therefore the AP1037 is suitable for the stepping motor drive in a space-saving and high current.

2. Features

<ul style="list-style-type: none">• Built-in PWM current control stepper motor driver	Active Decay Control
<ul style="list-style-type: none">• Single Power Supply Operation	Built-in Regulator for control circuit
<ul style="list-style-type: none">• Motor Operating Voltage	8.0 to 35.0V
<ul style="list-style-type: none">• Max Output Current	1.5A
<ul style="list-style-type: none">• On-Resistance (High+Low)	0.95Ω(typ.) @Ta=25°C
<ul style="list-style-type: none">• Input Interface	Clock-in method
<ul style="list-style-type: none">• Excitation Mode	2 Phase (Full step) 1-2 Phase (1/2 step) W1-2 Phase (1/4 step) 2W1-2 Phase (1/8 step)
<ul style="list-style-type: none">• Selectable PWM chopper frequency	39kHz/77kHz
<ul style="list-style-type: none">• Spike Noise Blanking Function	Without an external noise filter
<ul style="list-style-type: none">• Power Saving Function	VM Power Consumption is less than 10μA (Ta=25°C)
<ul style="list-style-type: none">• Selectable Motor Rotation Direction	Forward/Reverse
<ul style="list-style-type: none">• Corresponding to 3.3V/5V input signal	
<ul style="list-style-type: none">• Built-in Charge Pump Circuit	
<ul style="list-style-type: none">• Under Voltage Lockout Circuit(UVLO)	
<ul style="list-style-type: none">• Thermal Shutdown Circuit (TSD)	
<ul style="list-style-type: none">• Over Current Protection Circuit (OCP)	
<ul style="list-style-type: none">• Operating Temperature Range	-30 °C to +85°C
<ul style="list-style-type: none">• Package	AP1037AER: 24-pin QFN (4.0mm□) AP1037AEN: 32-pin QFN (5.0mm□)
<ul style="list-style-type: none">• Pin Compatible Lineups	AP1037AER, AP1037AEN : 1.5A AP1034AER, AP1034AEN : 2.0A
<ul style="list-style-type: none">• Applications	MFP/LBP, Scanner, Robotics ATM, Vending machines, Ticket machines, Moneychangers, Point of Sales System (POS) devices and etc.

3. Table of Contents

1. General Description	1
2. Features	1
3. Table of Contents	2
4. Block Diagram	3
5. Ordering Guide	3
6. Pin Configurations and Function	4
■ Pin Configurations	4
■ Functions.....	5
7. Absolute Maximum Ratings	6
8. Recommended Operating Conditions	7
9. Electrical Characteristics	7
10. Functional Descriptions	9
10.1 Input and Output of Terminal	9
■ Truth Table	9
■ ENABLEB : Output Enable Terminal	9
■ SLEEPB : Sleep Mode Setting Terminal.....	9
■ RESETB : Home Position Setting Terminal.....	10
■ MODE1,MODE2 : Motor Excitation Mode Setting Terminal	11
■ STEP : Step Input Terminal.....	11
■ DIR : Motor Rotation Direction Setting Terminal	12
■ FS : PWM Chopper Frequency Select Terminal	12
10.2 PWM Constant Current Control	13
■ Setting of the Output Current	13
■ Active Decay Mode Current Waveform	14
■ Blanking Time	14
■ Output Transistor Operating Mode.....	14
10.3 Micro-Step Function	15
■ Step Sequence	15
■ Example of Current Waveforms in Each Excitation Mode	16
10.4 Protection Functions	18
■ Thermal Shutdown Circuit (TSD)	18
■ Under Voltage Lock Output Circuit (UVLO).....	18
■ Over Current Protection Circuit (OCP)	19
11. Recommended External Circuit.....	20
■ Recommended External Circuit.....	20
■ Recommended Layout	21
12. Package	22
■ Outline Dimensions	22
■ Recommended Land Pattern	23
■ Marking.....	24
13. Revise History.....	25
IMPORTANT NOTICE	26

4. Block Diagram

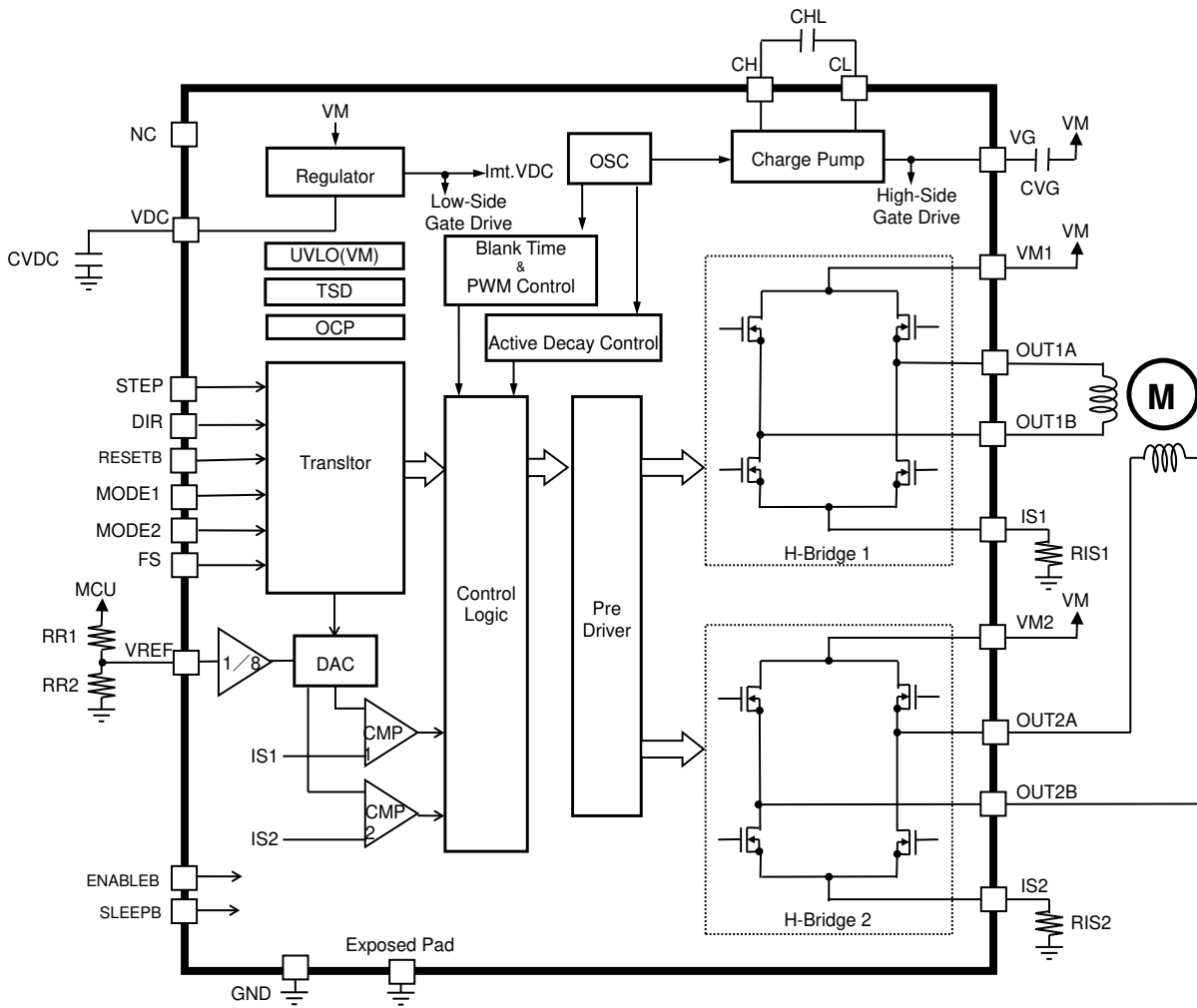

Figure 1. Block Diagram

5. Ordering Guide

AP1037AER	-30°C to +85°C	24-pin QFN
AP1037AEN	-30°C to +85°C	32-pin QFN

6. Pin Configurations and Function

■ Pin Configurations

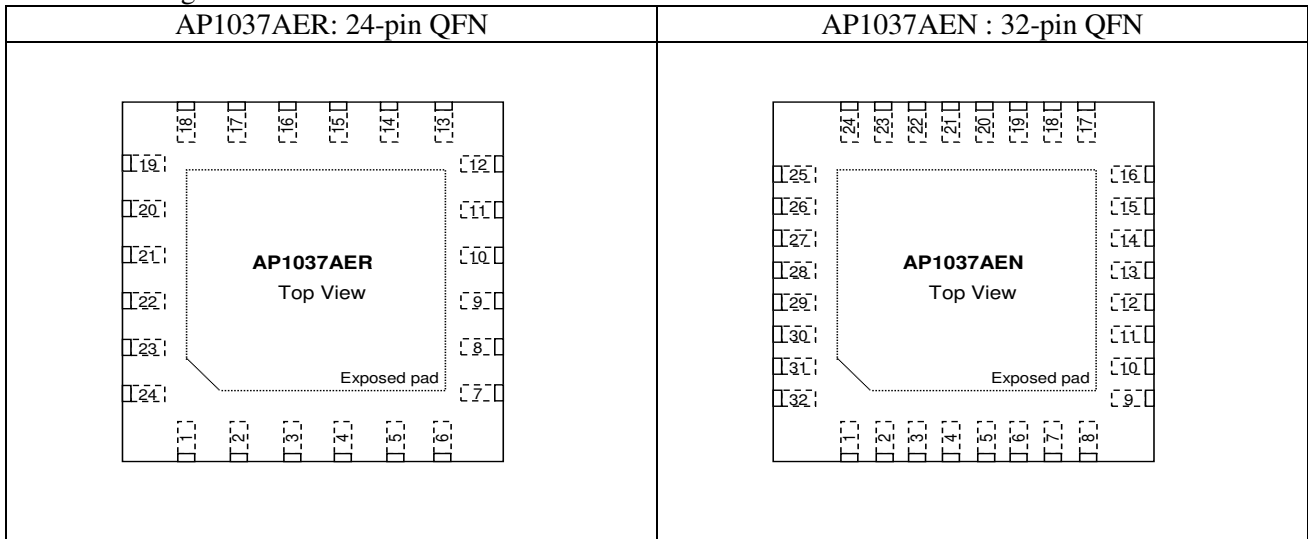

■ Functions

Pin Name	I/O	Pin Number		Function	Note
		24QFN	32QFN		
OUT2B	O	1	1	H-bridge 2 Output Terminal	
ENABLEB	I	2	5	Output Enable Terminal Please refer to Section10.1.	
GND	P	3,16	6,19	Ground Terminal	
CL	I	4	7	Connect Terminal for Charge Pump Capacitor	
CH	I	5	8	Connect Terminal for Charge Pump Capacitor	
VG	O	6	9	Connect Terminal for Stabilizing Capacitor	
VDC	O	7	10	Internal Regulator Output Terminal	Not connect external node
MODE1	I	8	11	Motor Excitation Mode Setting Terminal Please refer to Section10.1.	150kΩ pull-down
MODE2	I	9	12	Motor Excitation Mode Setting Terminal Please refer to Section10.1.	50kΩ pull-down
RESETB	I	10	13	Reset Input Terminal Please refer to Section10.1.	100kΩ pull-down
FS	I	11	14	Chopper Frequency Select Terminal Please refer to Section10.1.	100kΩ pull-down
SLEEPB	I	12	15	Sleep Mode Input Terminal Please refer to Section10.1.	100kΩ pull-down
STEP	I	14	17	Step Input Terminal Please refer to Section10.1.	
VREF	I	15	18	Input Terminal of Reference Voltage of PWM Constant Current Control	
DIR	I	17	20	Motor Rotate Direction Setting Terminal Please refer to Section10.1.	
OUT1B	O	18	24	H-bridge1 Output Terminal	
VM1	P	19	22	H-bridge1 Power Supply Terminal Please connect VM2 terminal in the system board.	
IS1	I	20	25	H-bridge1 Current Sense Terminal	
OUT1A	O	21	27	H-bridge1 Output Terminal	
OUT2A	O	22	30	H-bridge2 Output Terminal	
IS2	I	23	32	H-bridge2 Current Sense Terminal	
VM2	P	24	3	H-bridge2 Power Supply Terminal Please connect VM1 terminal in the system board.	
NC	-	13	2,4,16,21,23,26,28,29,31	No Connection Terminal	
Exposed Pad	-	-	-	Ground Terminal Please connect GND terminal in the system board.	For heat dissipation

Note 1. I (Input terminal), O (Output terminal), P (Power terminal)

7. Absolute Maximum Ratings

Parameter	Symbol	min	max	Unit	Condition	
Motor Power Supply Voltage	VM	-0.5	35	V		
Digital Input/Output Terminal Voltage (STEP, DIR, RESETB, MODE1, MODE2, ENABLEB, SLEEPB, FS)	Vterm1	-0.5	5.5	V		
VM Level Terminal Voltage (OUT1A,OUT1B, OUT2A,OUT2B)	Vterm2	-0.5	VM	V		
VG,CH Terminal Voltage	Vterm3	VM -0.5	VM +5.5	V	The Min value must not exceed -0.5V.	
VDC Terminal Voltage	VDC	-0.4	5.5	V		
V _{REF} Input Voltage	VREF	-0.5	VDC	V		
CL Terminal Voltage	VCL	-0.5	VDC	V		
IS1,IS2 Terminal Voltage	ISn	-0.5	1.5	V		
Output Current	Iload	-	2.0	A	(Note 3,Note 4)	
Power Dissipation	32QFN	PD1	-	3.9	W	Ta=25°C (Note 4, Note 5)
			-	2.0	W	Ta=85°C (Note 4, Note 5)
	24QFN	PD2	-	3.1	W	Ta=25°C (Note 4, Note 5)
			-	1.6	W	Ta=85°C (Note 4, Note 5)
Junction Temperature	Tj	-	150	°C		
Storage Temperature	Tstg	-40	150	°C		

Note 2. All above voltages are with respect to GND. The each power supply of VC and VM is sequence-free.

Note 3. For Power Dissipation, the output current rating may be limited by duty cycle, Ta, and PCB board heat sinking design.

Note 4. Exposed Pad must be connected to GND.

Note 5. A 4-layer JEDEC51 compliant board is used.

If the temperature exceeds 25°C, be sure to derate at [Figure 2](#).

24-pin QFN: $\theta_{JA} = 40^\circ\text{C/W}$

32-pin QFN: $\theta_{JA} = 32^\circ\text{C/W}$

WARNING: Operation at or beyond these limits may result in permanent damage to the device. Normal operation is not guaranteed at these extremes.

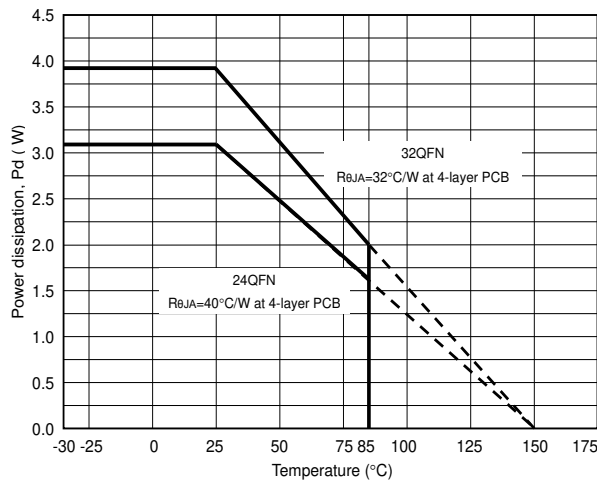

Figure 2. Maximum Power Dissipation

8. Recommended Operating Conditions

Parameter	Symbol	min	typ	max	Unit	Note
Motor Power Supply Voltage	VM	8.0	24.0	35.0	V	
Maximum Output Current (Continuous)	Iload	-	-	1.5	A	(Note 6)
Reference Voltage of PWM Constant Current Control	V _{REF}	0.0	-	3.6	V	Iload(100%)[A]=(V _{REF} /8)/RISn
Operating Temperature Range	Ta	-30	-	85	°C	

Note 6. Please have a thermal design so as not exceed T_j = 150 degrees and Power Dissipation.

Note 7. All voltages are with respect defined to GND (Exposed-Pad).

9. Electrical Characteristics

(Ta = 25°C, VM=24V, unless otherwise specified.)

Parameter	Symbol	Condition	min	typ	max	Unit
Quiescent Current						
VM Quiescent Current	I _{VM}	ENABLEB="L" SLEEPB="H"	-	-	12.0	mA
	I _{VMOFF}	ENABLEB="H" SLEEPB="H"	-	-	7.0	mA
	I _{VMPSV}	SLEEPB="L" SLEEP MODE	-	10	30	μA
H-bridge Circuit						
Driver On Resistance	R _{ON}	Iload = 1.12A	-	0.95	1.28	Ω
Body Diode Forward Voltage	V _F	I _F = 0.1A	-	0.8	1.2	V
Interface						
Input High Level Voltage	V _{IH}		2.0	-	-	V
Input Low Level Voltage	V _{IL}		-	-	0.8	V
Input Hysteresis (Note 9)	V _{hys}	STEP, DIR, RESETB, MODE1,MODE2,ENABLEB	0.2	0.4		V
Input Pulse Rise Time	t _R		-	-	1.0	μs
Input Pulse Fall Time	t _F		-	-	1.0	μs
Input High Level Current	I _{IH}	STEP,DIR, ENABLEB 5.5V applying	-1.0	-	1.0	μA
Input Low Level Current	I _{IL}	0V applying	-1.0	-	1.0	μA
Reference Voltage						
VREF Input Voltage Range	V _{REF}		0	-	3.6	V
VREF Input Current	I _{VREF}	V _{REF} =2V	-3	-	3	μA

(Ta = 25°C, VM=24V, unless otherwise specified.)

Parameter	Symbol	Condition	min	typ	max	Unit
Current Operation						
Blanking Time	t_B	FS="L"	1.3	2.6	5.2	μs
PWM Chopper Frequency	f_{CP1}	FS="L"	20	39	60	kHz
	f_{CP2}	FS="H"	40	77	120	kHz
Output Current Accuracy	$errI_{load}$	$V_{REF}=2V, \%I_{loadMAX}=38\%$	-15	-	+15	%
		$V_{REF}=2V, \%I_{loadMAX}=71\%$	-5	-	+5	%
		$V_{REF}=2V, \%I_{loadMAX}=100\%$	-5	-	+5	%
Protection Circuit						
Overcurrent protection trip level (High-side)	$I_{OCPTRIP_H}$		2.0	3.9	7.5	A
Overcurrent protection trip level (Low-side)	$I_{OCPTRIP_L}$	Ris=0.20 Ω ~0.30 Ω	1.6		7.5	A
Overcurrent protection deglitch time	t_{OCPDET}		3.0	6.8	23.3	μs
Under Voltage Detect Voltage (UVLO)	V_{MUVLO}		5.7	6.35	7.0	V
Thermal Shut Down Temperature	T_{TSD}	(Note 9)	150	175	200	$^{\circ}C$
Temperature Hysteresis	T_{TSDHYS}	(Note 9)	20	30	40	$^{\circ}C$

Note 8. All above voltages are with respect to GND.

Note 9. Not tested in production.

(Ta = 25°C, VM=24V, unless otherwise specified.)

Parameter	Symbol	min	typ	max	Unit
STEP Signal "H" Level Time	$t_{WH(STEP)}$	1.0	-	-	μs
STEP Signal "L" Level Time	$t_{WL(STEP)}$	1.0	-	-	μs
DIR, MODEx Signal Setup Time	$t_{S(STEP)}$	200	-	-	ns
DIR, MODEx Signal Hold Time	$t_{H(STEP)}$	200	-	-	ns

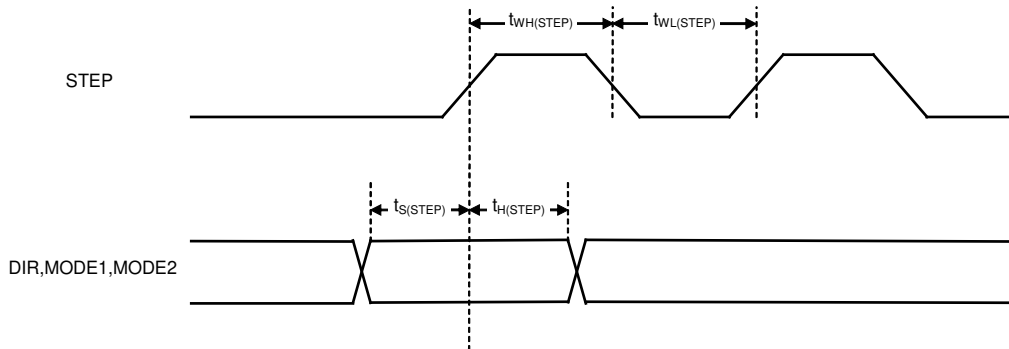

Figure 3. Timing Chart

10. Functional Descriptions

10.1 Input and Output of Terminal

■ Truth Table

Table 1. Output state against SLEEPB, RESETB and ENABLEB settings

SLEEPB	RESETB	ENABLEB	OUT1A OUT2A	OUT1B OUT2B	Condition
L	X	X	Output OFF (Hi-Z)	Output OFF (Hi-Z)	Sleep mode Internal control circuit : OFF
H	L	X	Output OFF (Hi-Z)	Output OFF (Hi-Z)	Home Position Setting Internal control circuit : ON
H	H	H	Output OFF (Hi-Z)	Output OFF (Hi-Z)	Disable mode Internal control circuit : ON
H	H	L	Output On	Output On	Enable mode DIR="H" : CW DIR="L" : CCW

Note 10. X : Don't Care

■ ENABLEB : Output Enable Terminal

When the input is "H", this pin turns off all the H-bridge outputs (motor output becomes Hi-Z). When the input is "L", all H-bridge outputs become enable. At that time, the input of sequencer (STEP,DIR,MODE1,MODE2) is independent of the logic of enable. ENABLEB input is the function of making H-Bridge output off. During output is off, the input of sequencer (STEP,DIR,MODE1,MODE2) is hold. Refer to [Figure 4](#).

Table 2. Settings of output enable terminal

ENABLEB	Condition
L	Operating mode
H	Output Hi-Z (Electrical angle hold)

■ SLEEPB : Sleep Mode Setting Terminal

When the input is "L", this pin sets the IC in sleep mode, and turns off all the H-bridge outputs, internal regulator, and charge pump circuit (motor output becomes Hi-Z). Control circuit is reset. If the "H" is input, the sleep mode is canceled. After the sleep mode is canceled, it restarts from the home position ([Table 9](#)). STEP input cannot be input during 3msec(max) after the sleep mode is canceled, to wait for the stable operation of internal charge pump. Refer to [Figure 5](#).

Table 3. Settings of sleep mode terminal

SLEEPB	Condition
L	SLEEP mode (Output : Hi-Z)
H	Operating mode

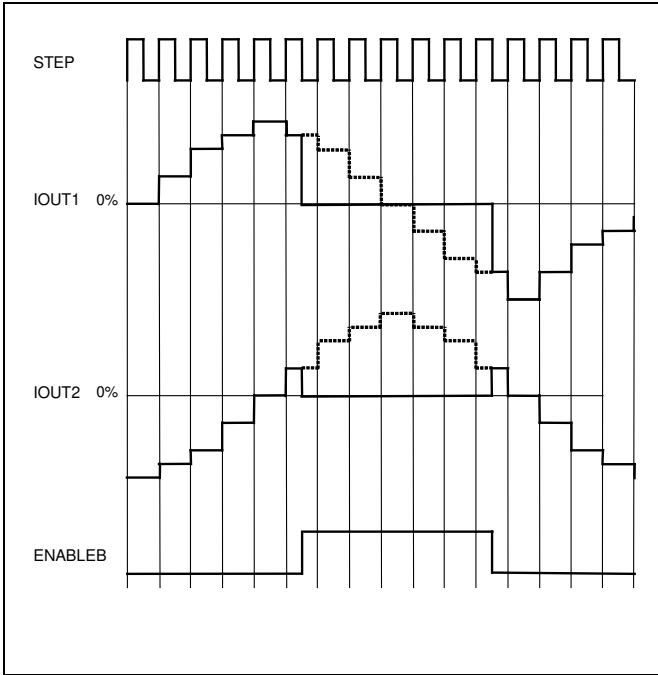

Figure 4. ENABLEB signal Timing Chart (W1-2 phase)

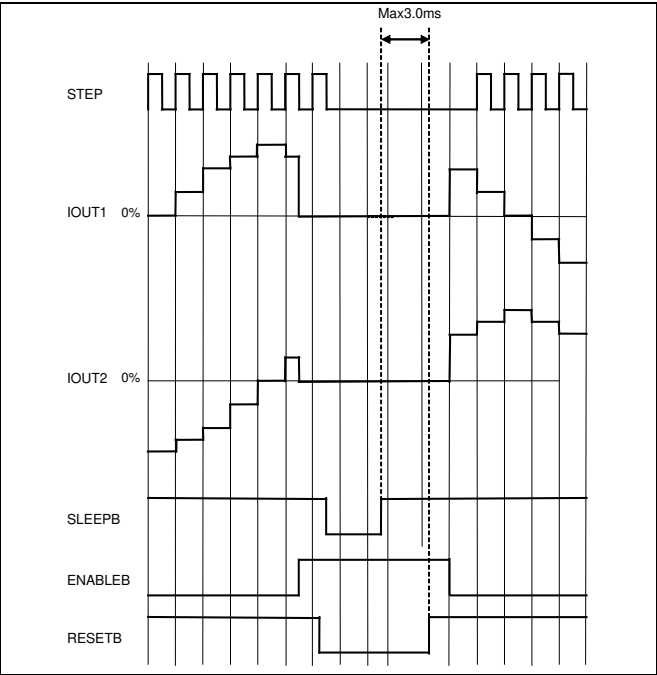

Figure 5. Sleep Mode Cancel Timing Chart (W1-2 phase)

■ RESETB : Home Position Setting Terminal

When the RESETB input is “H”, the sequencer is set at home position, and all the H-bridge outputs become off (motor output becomes Hi-Z). In this case, STEP input is ignored until “H” is input to the RESETB terminal. The internal circuits are in enable state. Refer to [Figure 6](#).

Table 4. Settings of home position terminal

RESETB	Condition
L	Output : Hi-Z (Home Position)
H	Operating mode

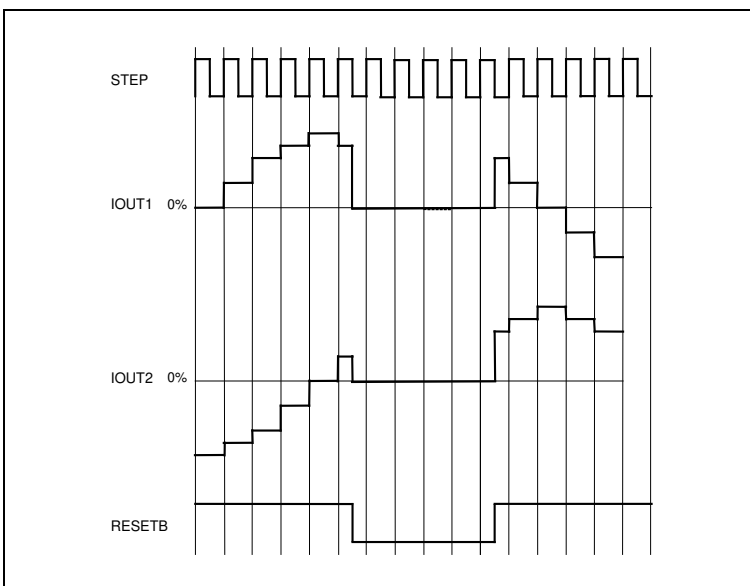

Figure 6. RESETB signal Timing Chart (W1-2 phase)

■ MODE1,MODE2 : Motor Excitation Mode Setting Terminal

The MODE1 and MODE2 terminals are used to configure stepping format as shown below.

Table 5. Settings of MODE terminals that excite motor

MODE1	MODE2	Excitation mode
L	L	2 phase (Full step)
H	L	1-2 phase (1/2step)
L	H	W1-2 phase (1/4step)
H	H	2W1-2phase (1/8step)

■ STEP : Step Input Terminal

The sequencer operates at the rising edge of the STEP input, electrical angle will proceed one at each step. Please design the pattern such that there is no jump of noise in STEP input terminal.

Table 6. Step excitation state against STEP input

STEP	Condition
Rising Edge	Sends excitation step
Falling Edge	Hold excitation step

■ DIR : Motor Rotation Direction Setting Terminal

This pin sets the direction of motor rotation. When changing the direction, a new setting is reflected on a rising edge of the CLK pin. Refer to Figure 7.

- CCW : H-bridge2 current is output by shifting 90degree ahead against the H-bridge1 current.
- CW : H-bridge2 current is output by shifting 90degree behind against the H-bridge1 current.

Table 7. Settings of rotate direction of motor

DIR	Condition
L	CCW (Reverse)
H	CW (Forward)

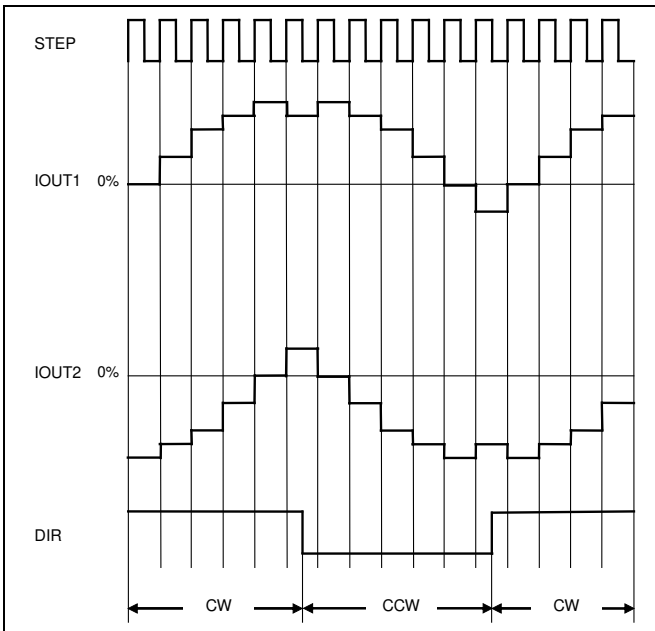

Figure 7. DIR signal Timing Chart (W1-2 phase)

■ FS : PWM Chopper Frequency Select Terminal

By inputting “H” to the FS input, it is possible to drive the PWM chopper frequency in 77kHz (typ). By inputting “L” or connecting GND, PWM chopper frequency becomes 39kHz (typ).

Please decide the setting of the FS input “50us” before than the ENABLEB input is set to "L".

Table 8. Settings of PWM chopper frequency select terminal

FS	Condition
L	$f_{CP}=39kHz(yp)$
H	$f_{CP}=77kHz(yp)$

10.2 PWM Constant Current Control

■ Setting of the Output Current

The frequency of the internal OSC circuit is used to drive a stepper motor in PWM constant current controlling. The maximum current value (Setting Current = Trip Current) is determined by a sense resistance (R_{IS}) for sensing current and the input voltage to the VREF pin (V_{REF}).

$$I_{load} (100\%) [A] = (V_{REF} / 8) / R_{IS}$$

VREF : PWM constant current setting voltage

RIS : H-Bridge sense resistor

VREF damping ratio : 1/8

Calculation example1 : $V_{REF}=2.4V$, $R_{IS}=0.24ohm$

$$I_{load} (100\%) [A] = (2.4 / 8) / 0.24ohm = 1.25A$$

Please use the resistance that is smaller than a resistance value to show in below for current sense resistance.

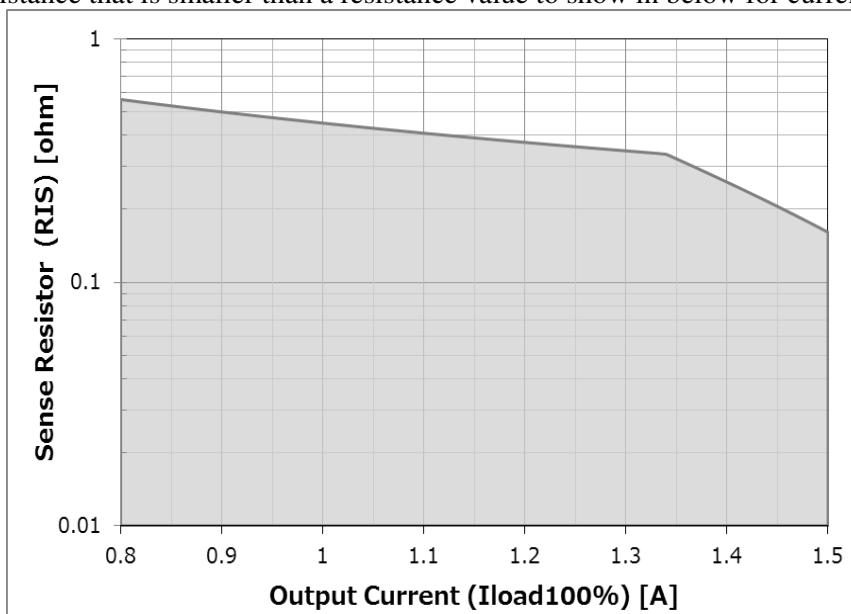

Figure 8. Recommended Sense Resistor

■ Active Decay Mode Current Waveform

The AP1037 selects the decay mode automatically for better current follower performance. Usually, it operates in slow decay mode but changes to fast decay mode when switching the step during current decreasing period.

Also there is Pre fast decay before Charge mode. Therefore if in the low target current, it is possible to reduce the current distortion.

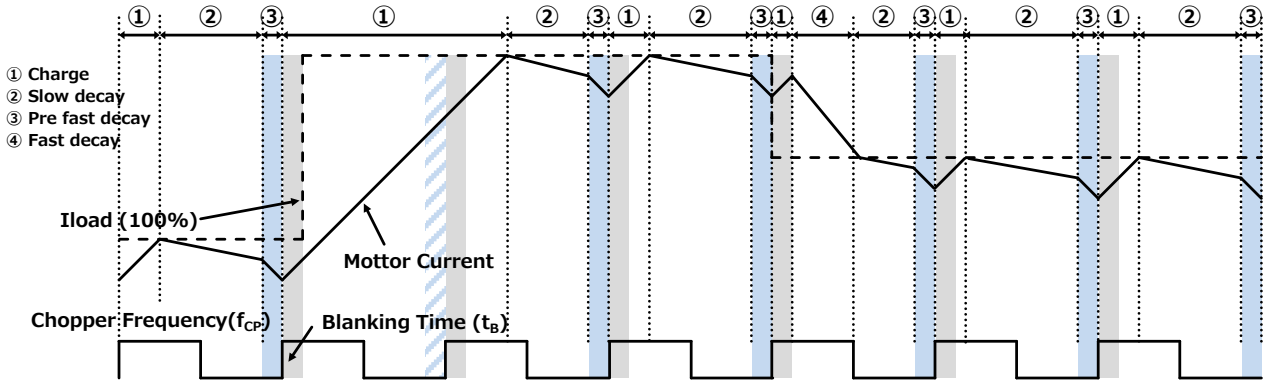

Figure 9. Active Decay Mode Current Waveform

■ Blanking Time

Recovery current of parasitic diode arises when the decay mode changes charge mode during PWM constant current operation. It can flow into current sense resistor, and the noise of current sense terminal (IS1,IS2) cause the malfunction of internal comparator (CMP1,CMP2). To prevent malfunction, the detection of current sense comparator is blanking during Charge mode. The blanking time of the IC is 2.6us fixed at FS=L, 1.3us fixed at FS=H.

■ Output Transistor Operating Mode

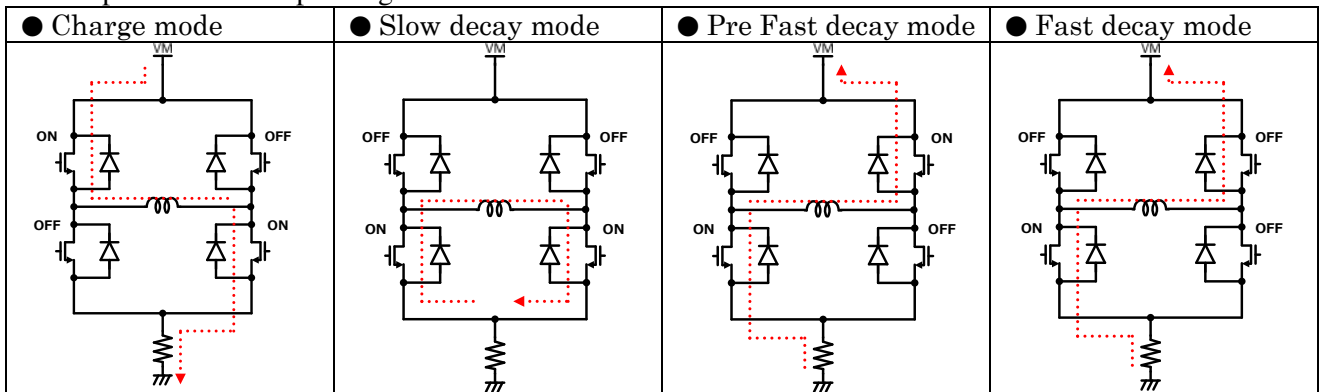

Figure 10. Current Flow of Mixed Decay Mode

10.3 Micro-Step Function

■ Step Sequence

Table 9. Setting Current Comparison of Excitation Modes

2 phase (Full step)	1-2 phase (1/2step)	W1-2 phase (1/4step)	2W1-2 phase (1/8step)	Phase1 Current [%I _{loadmax}]	Phase2 Current [%I _{loadmax}]	Step Angle [°]
	1	1	1	100	0	0.00
			2	98	20	11.25
		2	3	92	38	22.50
			4	83	56	33.75
1	2	3	5	71	71	45.00
			6	56	83	56.25
		4	7	38	92	67.50
			8	20	98	78.75
	3	5	9	0	100	90.00
			10	-20	98	101.25
		6	11	-38	92	112.50
			12	-56	83	123.75
2	4	7	13	-71	71	135.00
			14	-83	56	146.25
		8	15	-92	38	157.50
			16	-98	20	168.75
	5	9	17	-100	0	180.00
			18	-98	-20	191.25
		10	19	-92	-38	202.50
			20	-83	-56	213.75
3	6	11	21	-71	-71	225.00
			22	-56	-83	236.25
		12	23	-38	-92	247.50
			24	-20	-98	258.75
	7	13	25	0	-100	270.00
			26	20	-98	281.25
		14	27	38	-92	292.50
			28	56	-83	303.75
4	8	15	29	71	-71	315.00
			30	83	-56	326.25
		16	31	92	-38	337.50
			32	98	-20	348.75

 : Home micro-step position at Step Angle 45°

Note 11. When the excitation mode is changed to a coarser mode, it is set to the closest position in the rotate direction set by DIR signal. However, the motor could step-out or misstep depends on the operation state of motor during switching time. The changing sequence of the excitation mode should be determined by adequate evaluation.

Table 10. When changing to 2phase excitation mode at eighth position from 2W1-2phase excitation mode

DIR	Before	After
	2W1-2	2phase(4step)
H	8step position	2step position
L	8step position	1step position

■ Example of Current Waveforms in Each Excitation Mode

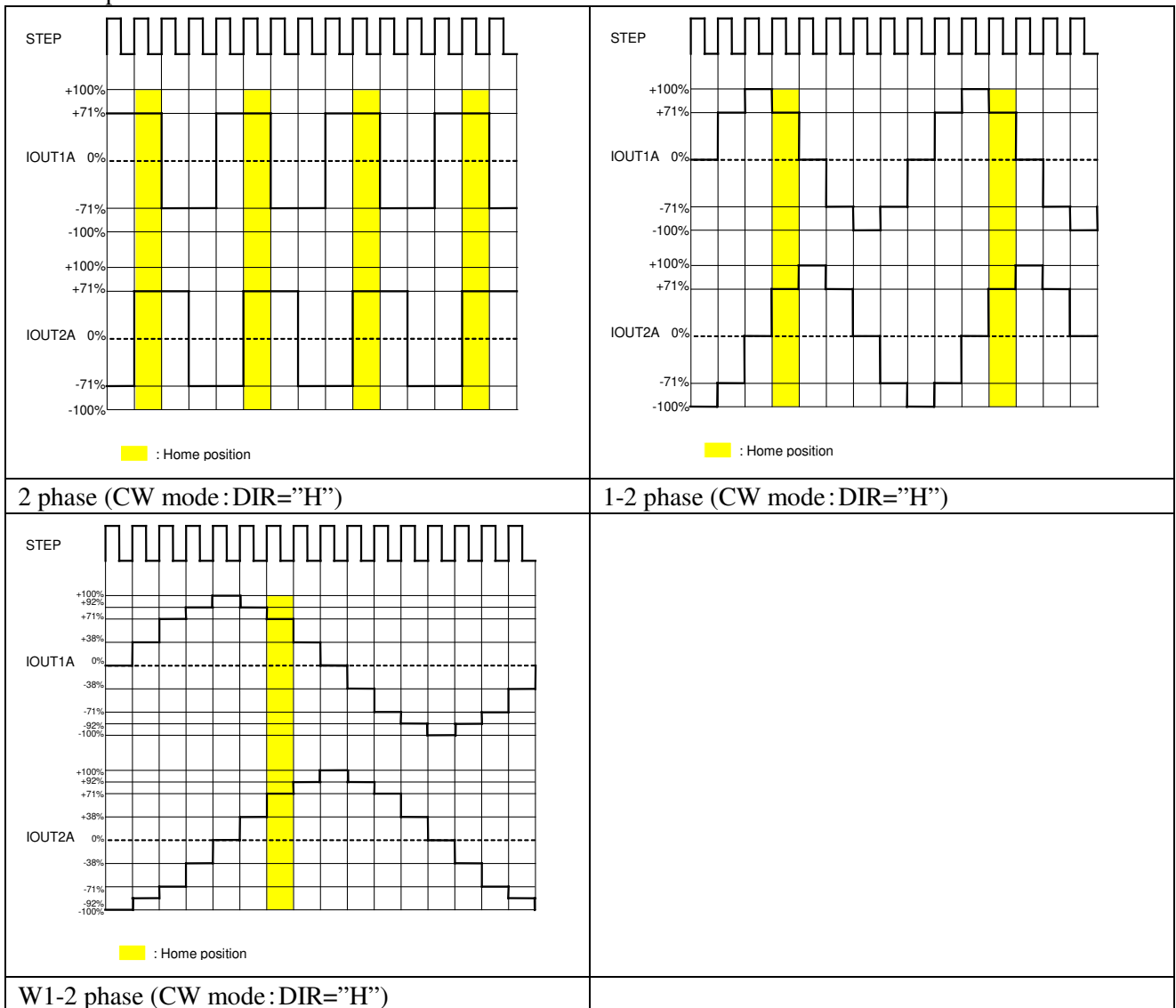

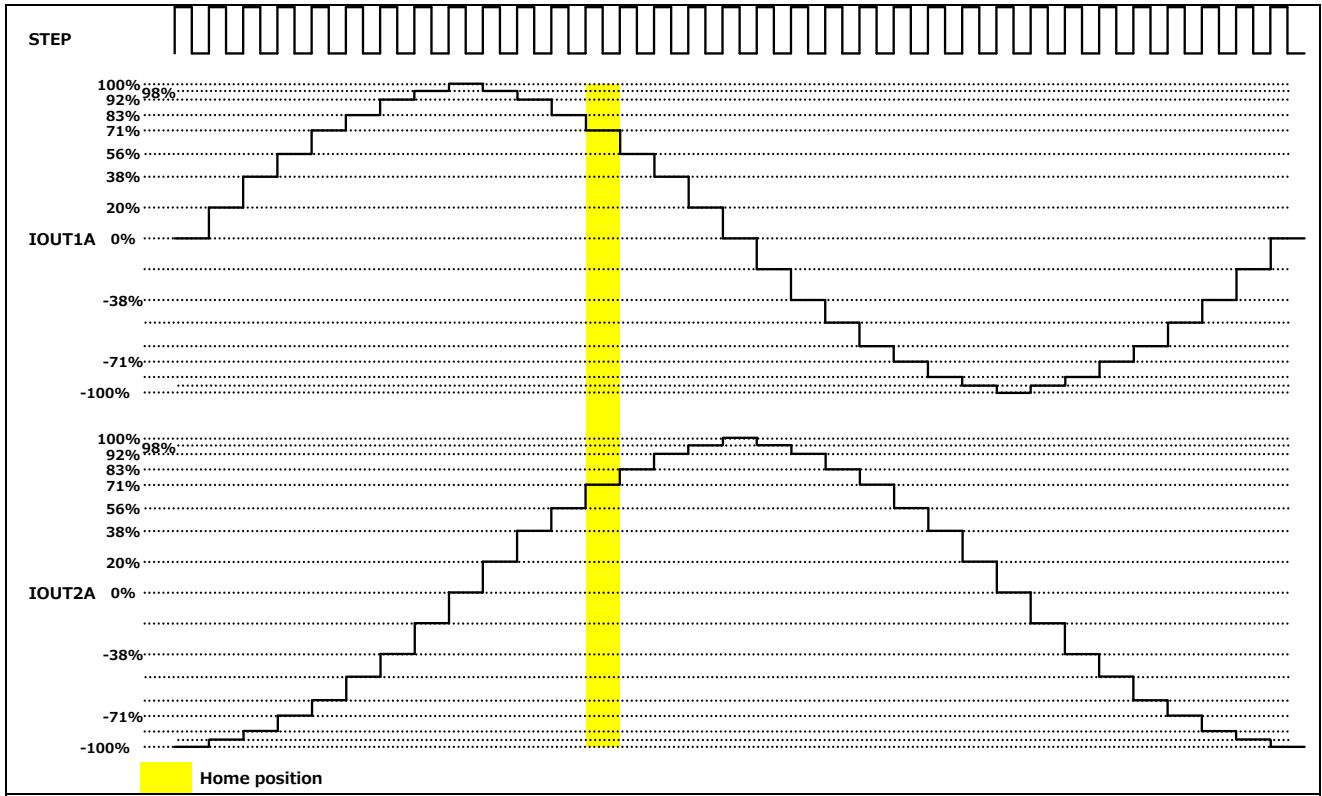

2W1-2 phase (CW mode: DIR="H")

Note 12. "+" means the current is flowing through the OUT1B from OUT1A and the OUT2B from OUT2A.

10.4 Protection Functions

Table 11. Recovery type and the output state of the protection circuit

Protection Circuit		H-Bridge Outputs	Recovery type
Thermal Shutdown (TSD)		Hi-Z	Automatic
Under Voltage Lockout (UVLO)		Hi-Z	Automatic
Over Current Protection (OCP)	Shorted-Load	Hi-Z	Latch off
	Shorted-to-Ground		
	Shorted-to-Power		

■ Thermal Shutdown Circuit (TSD)

If the internal temperature of the IC (T_j) reaches 175 °C (typ), the H-Bridge outputs Hi-Z. In addition, it will automatically return to the normal operation when it becomes less than 145 °C (typ).

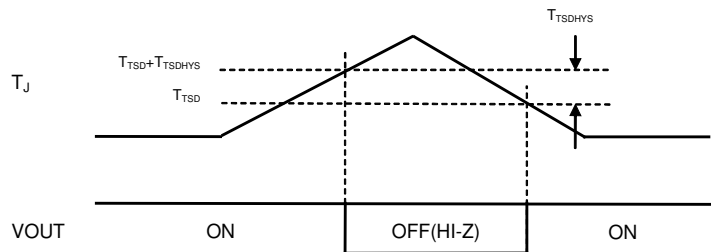

Figure 11. TSD Timing Chart

■ Under Voltage Lock Output Circuit (UVLO)

When VM voltage is lower than 6.35V (typ), the H-Bridge output is the Hi-Z. Please note that this circuit does not operate during sleep mode. When UVLO operates, internal circuits which includes H-Bridge output, internal regulator, charge pump circuit become disable, and also the control circuit is reset (initialize). If VM voltage goes up than the specified voltage, UVLO is released. After the UVLO released, it restarts from the home position. STEP input cannot be input during 3msec after the UVLO is canceled, to wait for the stable operation of internal charge pump.

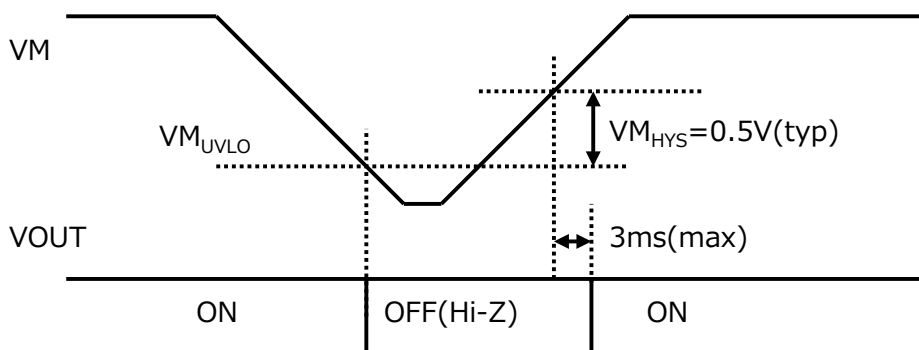

Figure 12. UVLO Timing Chart

■ Over Current Protection Circuit (OCP)

The IC has over current protection circuit to prevent breakdown of H-Bridge drivers. If the specified current flows, H-Bridge outputs of all channel becomes latch off. It recovers by re-input of the motor power supply voltage (VM) or input of SLEEPB or RESETB.

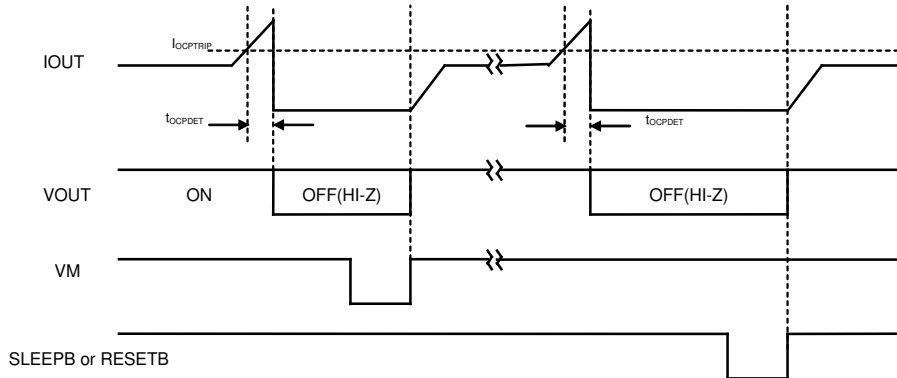

Figure 13. OCP Timing Chart

Note13. If latch is released under the abnormal condition after OCP operation, the IC may repeat the operation(latch → return → latch) . This will be the cause of heat generation and deterioration of the IC. In addition, please do not make chattering noise for SLEEPB or RESETB signal because it causes the malfunction of the OCP circuit and may let an IC damage.

Note14. When the Shorted-Load or the Shorted-to-Power occurs, the current comparison comparator works. After the blanking time, the IC becomes slow decay mode and repeats normal operation every chopper cycle.

Note15. If the current sense resistors(R_{IS}) are shorted, the OCP operates before the current comparator comparison works in all conditions, so that the output of all channels will be Hi-Z.

Note16. Low side OCP detects overcurrent by comparing the voltage drop across a current sense resistor (R_{IS}) corresponding to the load current with the reference voltage. It should be noted that the overcurrent threshold will be increased using a low value sense resistor.

11. Recommended External Circuit

■ Recommended External Circuit

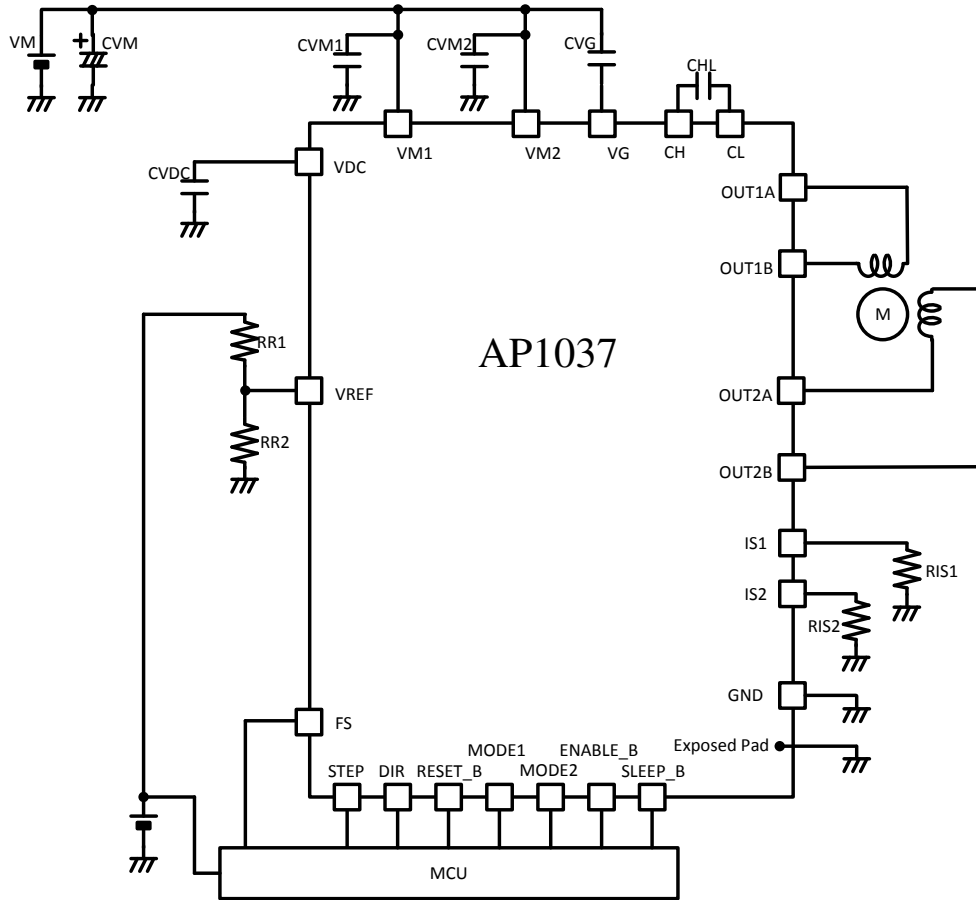

Figure 14. Recommended External Circuit

Table 12. Recommended External Components

Items	typ	Unit	備考
CVM	100	μF	Electrolytic Capacitor
CVM1	0.22	μF	Ceramic Capacitor
CVM2	0.22	μF	Ceramic Capacitor
CHL	0.01	μF	Ceramic Capacitor
CVG	0.1	μF	Ceramic Capacitor
CVDC	0.22	μF	Ceramic Capacitor
RIS1	0.24	Ω	At 1.25[A]setting (@VREF=2.38V)
RIS2	0.24	Ω	At 1.25[A]setting (@VREF=2.38V)
RR1	33	kΩ	At VREF=2.38V setting (@VC=5.0V)
RR2	30	kΩ	At VREF=2.38V setting (@VC=5.0V)

Note 17. Above values are examples. Please choose appropriate external components for your system board.
 Note 18. Capacitance of CVM and CVC should be determined in consideration of the load current profile, the load capacitance, the line resistance and etc. of the actual system board.

■ Recommended Layout

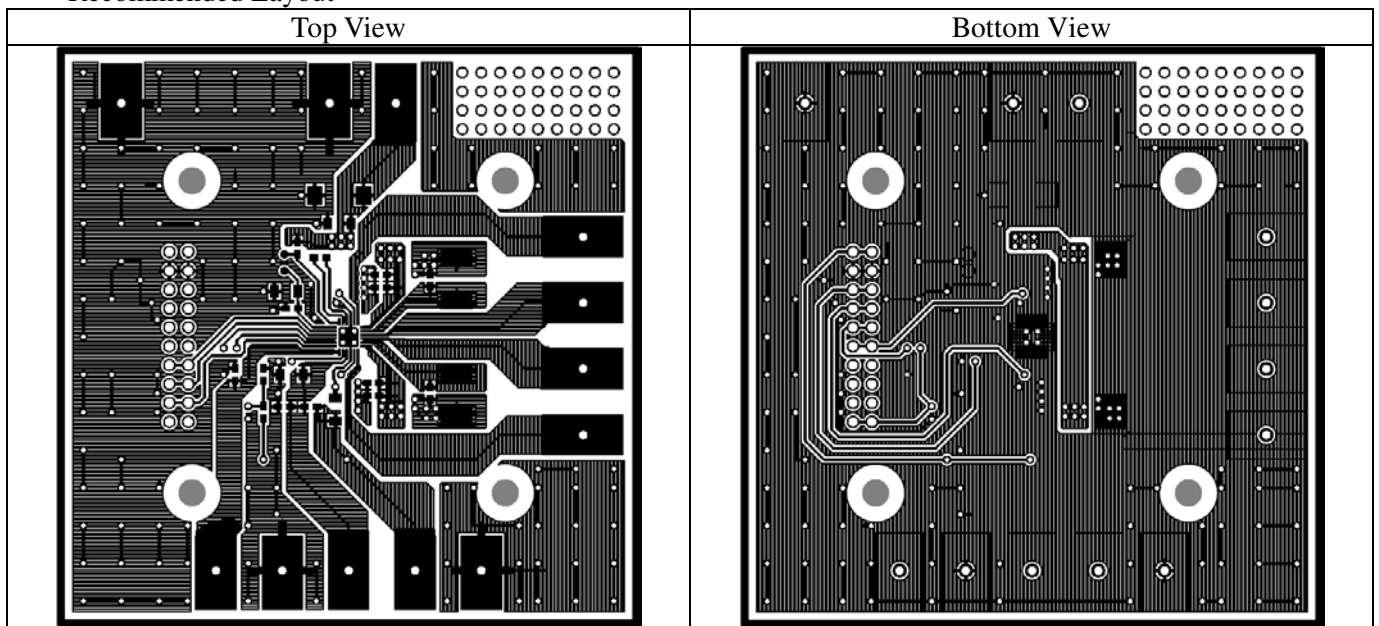

Figure 15. Recommended Layout Pattern

Note 19. Please layout the large ground plane on the PCB.

Note 20. Exposed Pad (heat sink) is common to the ground terminal. Please connect it to the ground of the PCB.

Note 21. The ground via of the PCB back side under IC mounted area is effective for heat radiation to each layer of the PCB.

12. Package

■ Outline Dimensions

● AP1037AER : 24-pin QFN Package

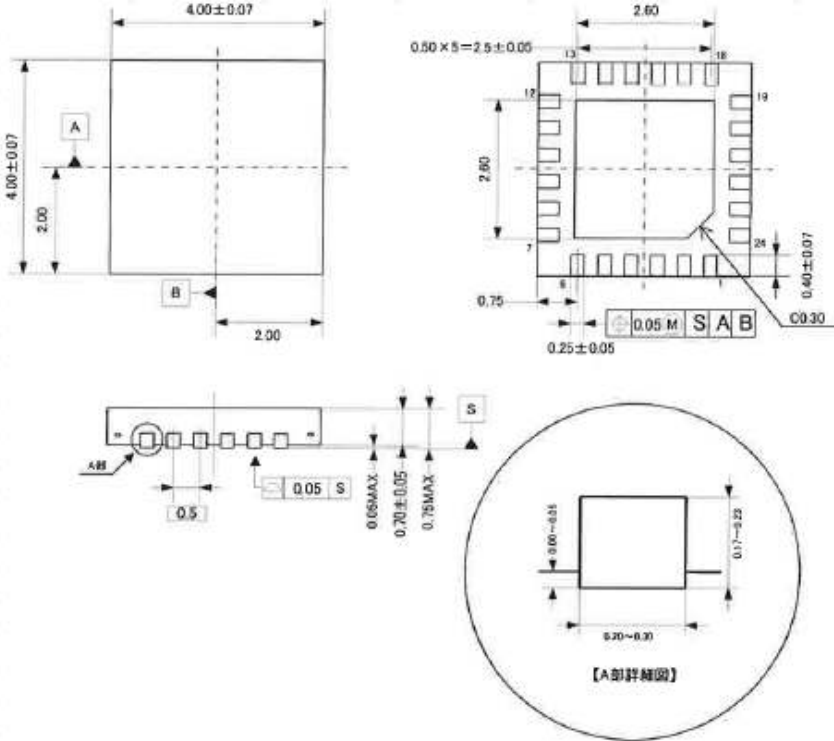

Unit : mm

● AP1037AEN : 32-pin QFN Package

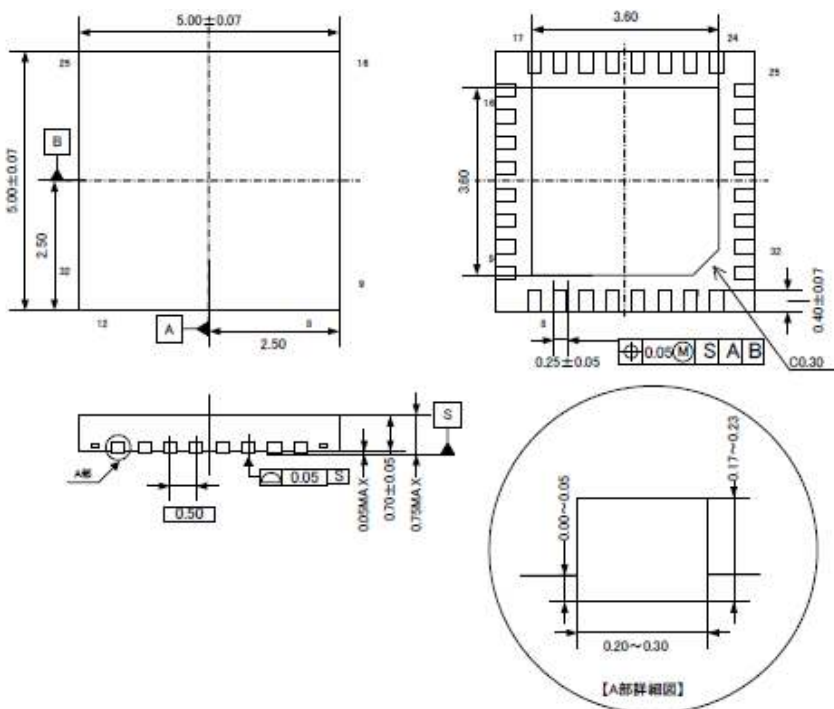

Unit : mm

■ Recommended Land Pattern

- AP1037AER : 24-pin QFN Package

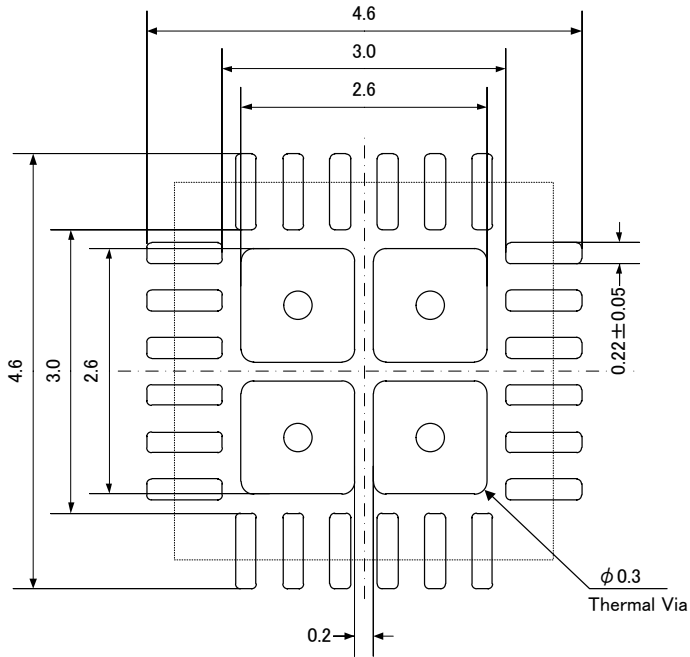

【unit: mm】

- AP1037AEN : 32-pin QFN Package

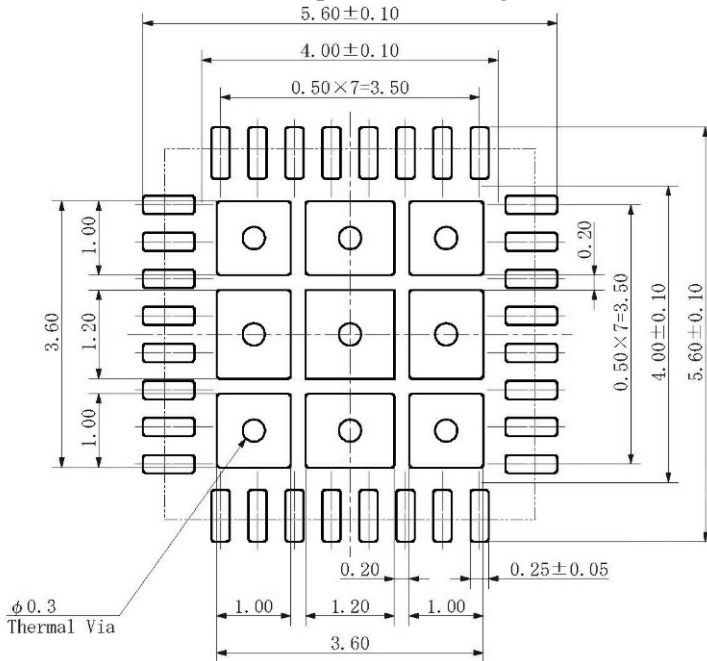

【unit: mm】

*The most suitable dimensions of the mount pad change by a substrate material, solder paste materials, a soldering method, device precision. It is therefore recommended that customers contact the actual design should be optimized according to the situation.

- Marking
- AP1037AER

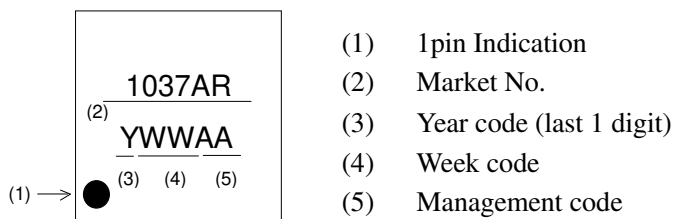

- (1) 1pin Indication
- (2) Market No.
- (3) Year code (last 1 digit)
- (4) Week code
- (5) Management code

- AP1037AEN

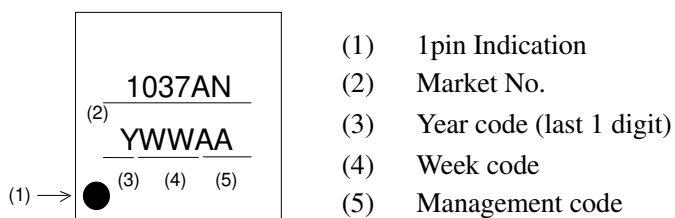

- (1) 1pin Indication
- (2) Market No.
- (3) Year code (last 1 digit)
- (4) Week code
- (5) Management code

13. Revise History

Date (YY/MM/DD)	Revision	Page	Contents
17/02/02	00	-	First Edition

IMPORTANT NOTICE

0. Asahi Kasei Microdevices Corporation (“AKM”) reserves the right to make changes to the information contained in this document without notice. When you consider any use or application of AKM product stipulated in this document (“Product”), please make inquiries the sales office of AKM or authorized distributors as to current status of the Products.
1. All information included in this document are provided only to illustrate the operation and application examples of AKM Products. AKM neither makes warranties or representations with respect to the accuracy or completeness of the information contained in this document nor grants any license to any intellectual property rights or any other rights of AKM or any third party with respect to the information in this document. You are fully responsible for use of such information contained in this document in your product design or applications. **AKM ASSUMES NO LIABILITY FOR ANY LOSSES INCURRED BY YOU OR THIRD PARTIES ARISING FROM THE USE OF SUCH INFORMATION IN YOUR PRODUCT DESIGN OR APPLICATIONS.**
2. The Product is neither intended nor warranted for use in equipment or systems that require extraordinarily high levels of quality and/or reliability and/or a malfunction or failure of which may cause loss of human life, bodily injury, serious property damage or serious public impact, including but not limited to, equipment used in nuclear facilities, equipment used in the aerospace industry, medical equipment, equipment used for automobiles, trains, ships and other transportation, traffic signaling equipment, equipment used to control combustions or explosions, safety devices, elevators and escalators, devices related to electric power, and equipment used in finance-related fields. Do not use Product for the above use unless specifically agreed by AKM in writing.
3. Though AKM works continually to improve the Product’s quality and reliability, you are responsible for complying with safety standards and for providing adequate designs and safeguards for your hardware, software and systems which minimize risk and avoid situations in which a malfunction or failure of the Product could cause loss of human life, bodily injury or damage to property, including data loss or corruption.
4. Do not use or otherwise make available the Product or related technology or any information contained in this document for any military purposes, including without limitation, for the design, development, use, stockpiling or manufacturing of nuclear, chemical, or biological weapons or missile technology products (mass destruction weapons). When exporting the Products or related technology or any information contained in this document, you should comply with the applicable export control laws and regulations and follow the procedures required by such laws and regulations. The Products and related technology may not be used for or incorporated into any products or systems whose manufacture, use, or sale is prohibited under any applicable domestic or foreign laws or regulations.
5. Please contact AKM sales representative for details as to environmental matters such as the RoHS compatibility of the Product. Please use the Product in compliance with all applicable laws and regulations that regulate the inclusion or use of controlled substances, including without limitation, the EU RoHS Directive. AKM assumes no liability for damages or losses occurring as a result of noncompliance with applicable laws and regulations.
6. Resale of the Product with provisions different from the statement and/or technical features set forth in this document shall immediately void any warranty granted by AKM for the Product and shall not create or extend in any manner whatsoever, any liability of AKM.
7. This document may not be reproduced or duplicated, in any form, in whole or in part, without prior written consent of AKM.