

REVISIONS					
P	LTR	DESCRIPTION	DATE	DWN	APVD
G		REVISED PER ECN-21-125525	12NOV2021	AK	SZ

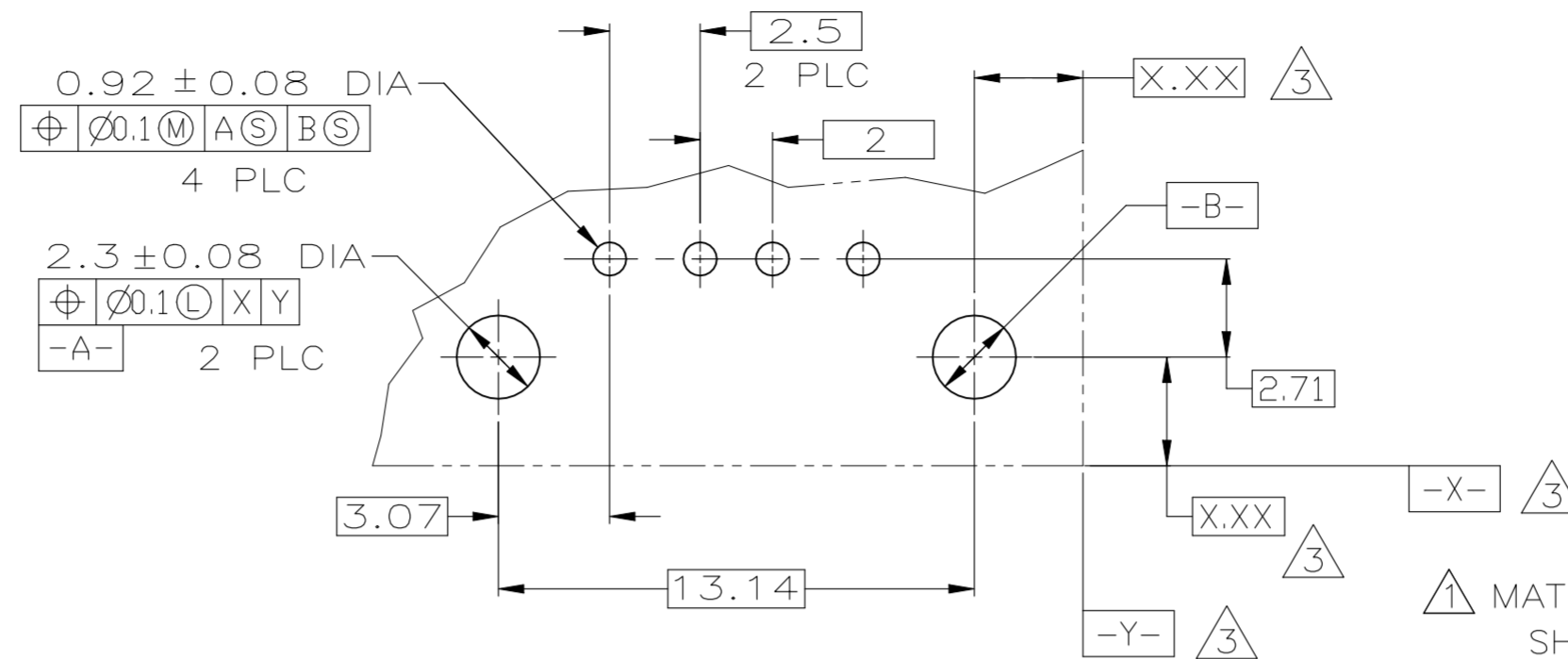

PC BOARD MOUNTING DIMENSIONS ④

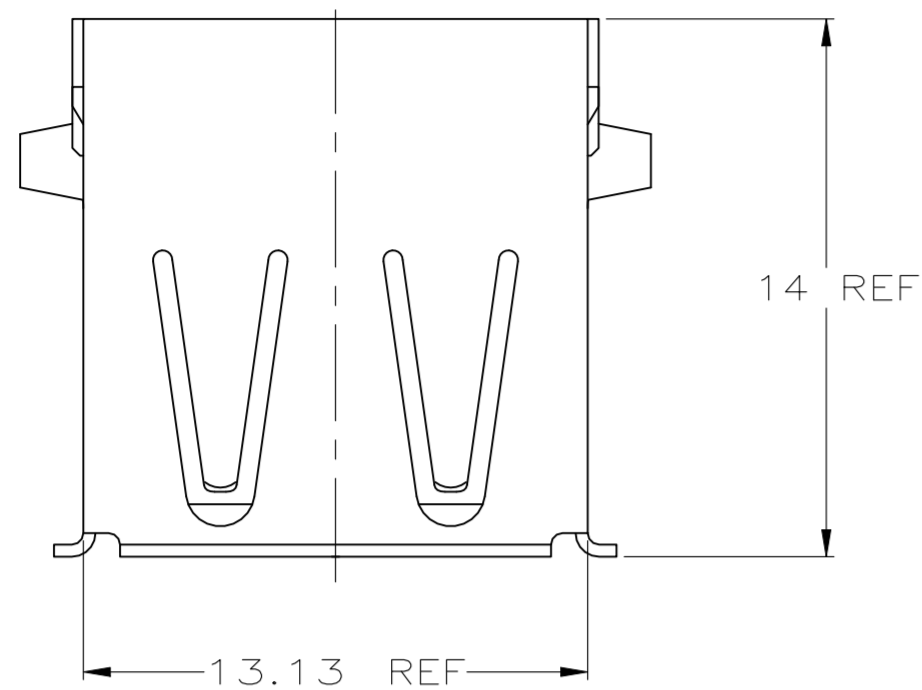
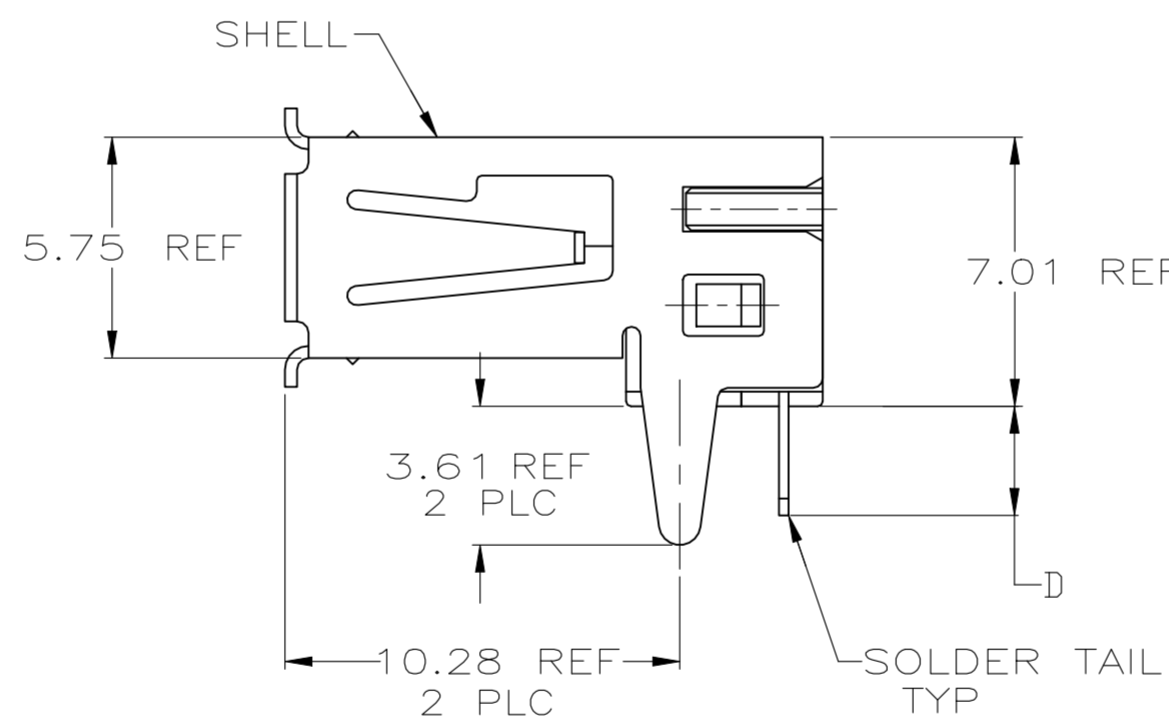
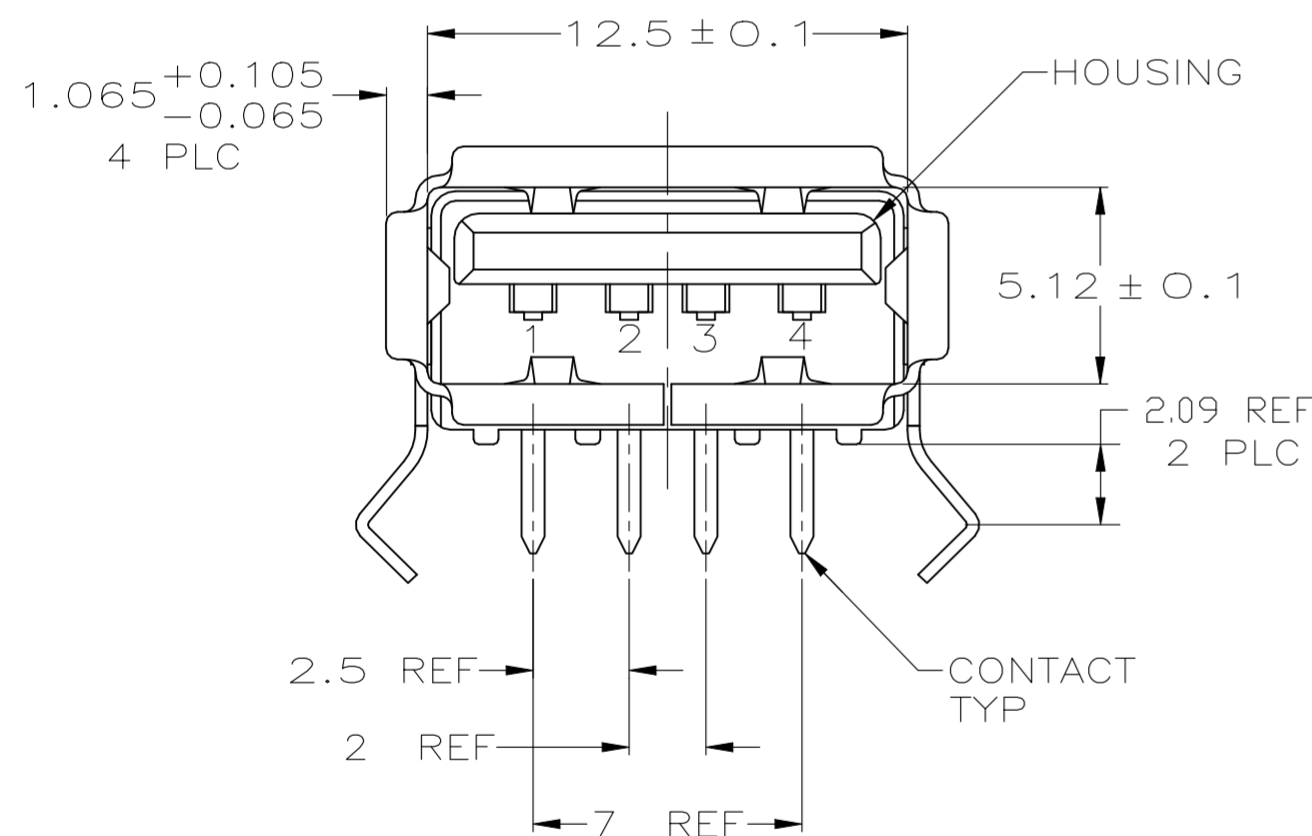

- ① MATERIAL:
SHELL: STAINLESS STEEL & CONTACTS- COPPER ALLOY.
HOUSING: UL 94V-0 RATED, THERMOPLASTIC, COLOR SEE TABLE.
- ② PLATING:
CONTACTS: 0.076μm MINIMUM GOLD OVER 0.76μm MINIMUM PALLADIUM-NICKEL ON MATING AREA.
3.8μm MINIMUM MATTE TIN ON SOLDER TAILS.
BOTH OVER 1.27μm MINIMUM NICKEL.
CONTACT ALTERNATE PLATING: 0.76μm MIN GOLD ON MATING AREA, 3.80μm MIN MATTE TIN ON SOLDER TAILS, BOTH OVER 1.27μm MIN NICKEL.
SHELL: 2~5μm MINIMUM BRIGHT TIN
- ③ DATUM AND BASIC DIMENSIONS ESTABLISHED BY CUSTOMER.
- ④ RECOMMENDED PC BOARD THICKNESS OF 1.57 mm.
- ⑤ PLATING:
CONTACTS: 0.76μm MINIMUM PALLADIUM-NICKEL ON MATING AREA.
3.8μm MINIMUM MATTE TIN ON SOLDER TAILS.
BOTH OVER 1.27μm MINIMUM NICKEL.
SHELL: 2~5μm MINIMUM BRIGHT TIN

⑤	YES	2.84	BLACK	2-292303-0 ⑨
②	YES	2.29	BLACK	1-292303-9 ⑧
②	NO	3.81	BLACK	1-292303-5
②	NO	3.56	BLACK	1-292303-4
②	NO	3.20	BLACK	1-292303-3
②	YES	3.30	BLACK	1-292303-2
②	YES	2.29	BLACK	292303-6
②	YES	2.84	NATURAL	292303-5
②	YES	2.84	BLACK	292303-4
②	NO	2.84	NATURAL	292303-3
②	NO	2.29	BLACK	292303-2
②	NO	2.84	BLACK	292303-1
CONTACT PLATING	HIGH TEMPERATURE COMPATIBLE	D	HOUSING COLOR	PART NUMBER

THIS DRAWING IS A CONTROLLED DOCUMENT.

DWN	J.JIANG	19FEB04
CHK	S.YAO	19FEB04
APVD	T.SASAKI	19FEB04

TE Connectivity Ltd.

RECEPTACLE ASSEMBLY RIGHT
ANGLE, 4 POSITION, T/H & SMT
USB, LEAD FREE VERSION

108-60034

SIZE: A2 CAGE CODE: 00779 DRAWING NO: C=292303

SCALE: 5:1 SHEET: 1 of 5 REV: G

DIMENSIONS:	TOLERANCES UNLESS OTHERWISE SPECIFIED:
mm	
0 PLC	± -
1 PLC	± -
2 PLC	± 0.25
3 PLC	± -
4 PLC	± -
ANGLES	± -
MATERIAL	FINISH
①	SEE TABLE

REVISIONS					
P	LTR	DESCRIPTION	DATE	DWN	APVD
-	-	SEE SHEET 1	-	-	-

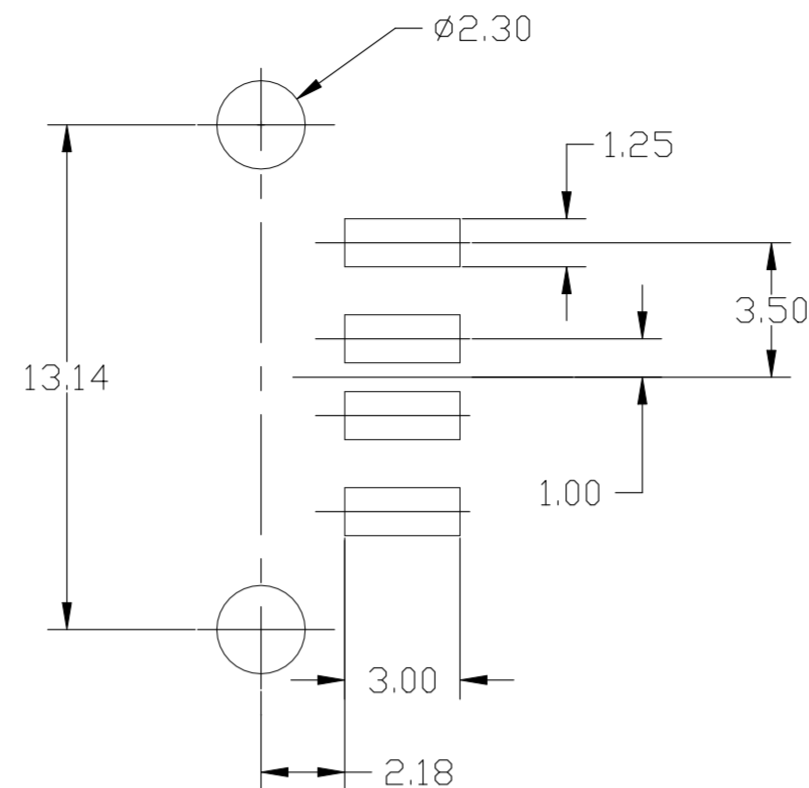
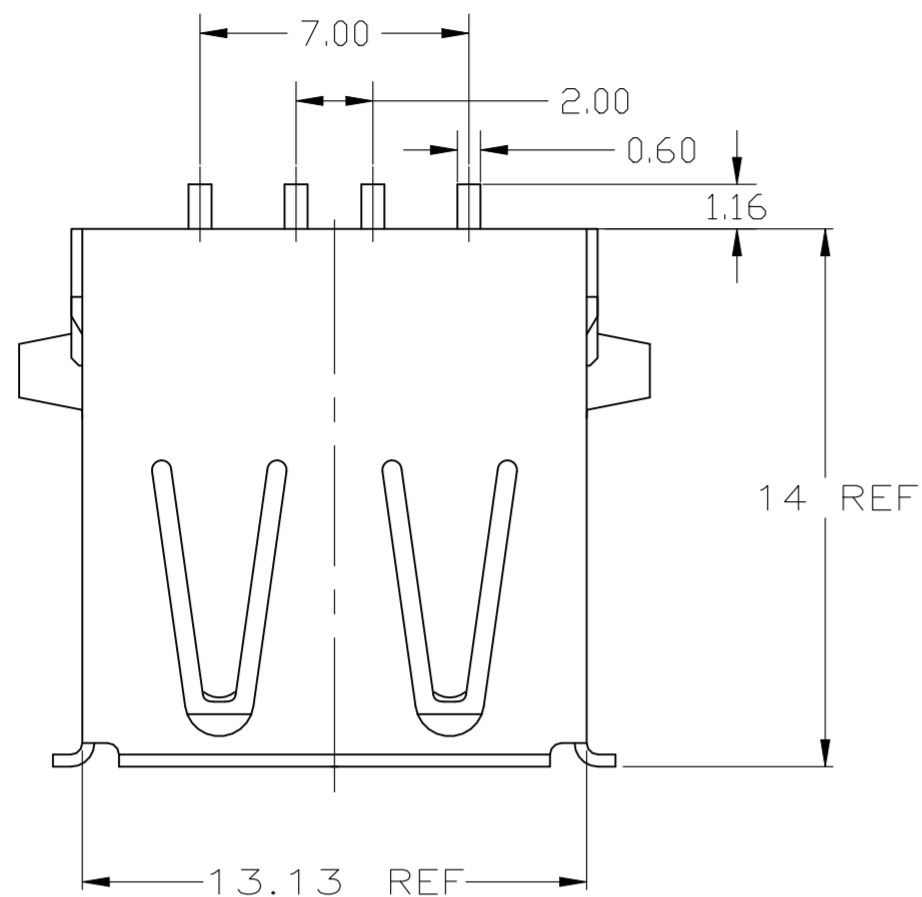

- ⚠ MATERIAL:
SHELL:- STAINLESS STEEL & CONTACTS- COPPER ALLOY.
HOUSING: UL 94V-0 RATED, THERMOPLASTIC, COLOR SEE TABLE.
- ⚠ PLATING:
CONTACTS: 0.076 μm MINIMUM GOLD OVER 0.76 μm MINIMUM PALLADIUM-NICKEL ON MATING AREA.
3.8 μm MINIMUM MATTE TIN ON SOLDER TAILS.
BOTH OVER 1.27 μm MINIMUM NICKEL.
CONTACT ALTERNATE PLATING: 0.76μm MIN GOLD ON MATING AREA, 3.80 μm MIN MATTE TIN ON SOLDER TAILS, BOTH OVER 1.27 μm MIN NICKEL.
SHELL: 2~5 μm MINIMUM BRIGHT TIN
- ⚠ RECOMMENDED PC BOARD THICKNESS OF 1.42.

RECOMMENDED PC BOARD MOUNTING LAYOUT ⚠
(TOLERANCE=±0.05)

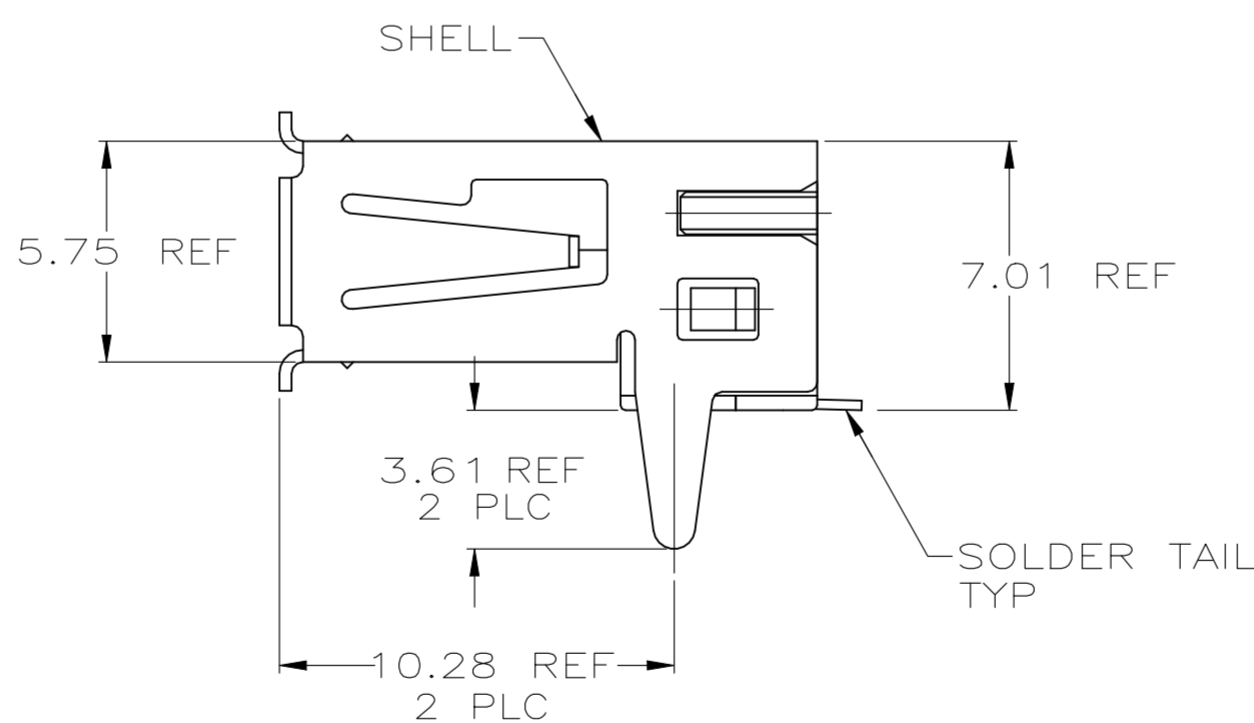
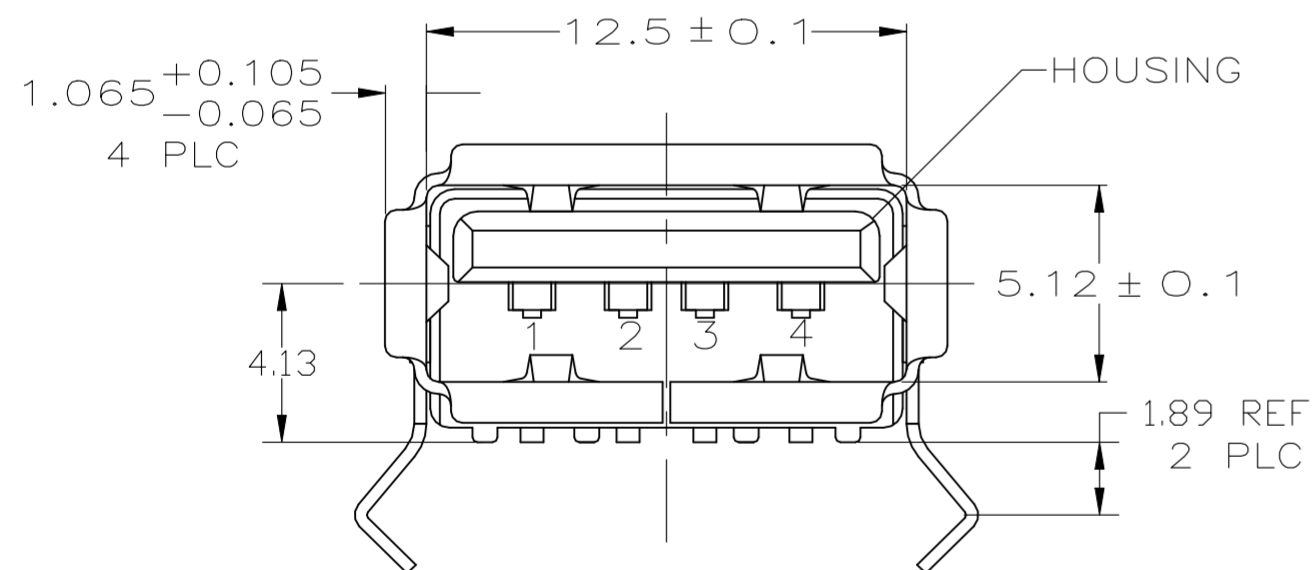

OBSELETE	YES	BLACK	3-292303-1 E10
	YES	BLACK	1-292303-1
	YES	NATURAL	292303-7
	HIGH TEMPERATURE COMPATIBLE	HOUSING COLOR	PART NUMBER

THIS DRAWING IS A CONTROLLED DOCUMENT.		DWN J.JIANG 19FEB04	TE TE Connectivity Ltd.	
DIMENSIONS: mm		CHK S.YAO 19FEB04		
TOLERANCES UNLESS OTHERWISE SPECIFIED:		APVD T.SASAKI 19FEB04	NAME	
0 PLC ± -		PRODUCT SPEC	RECEPTACLE ASSEMBLY RIGHT	
1 PLC ± -		APPLICATION SPEC	ANGLE, 4 POSITION, T/H & SMT	
2 PLC ± 0.25			USB, LEAD FREE VERSION	
3 PLC ± -			SIZE	CAGE CODE
4 PLC ± -			A2	00779
ANGLES ± -			DRAWING NO	RESTRICTED TO
FINISH		WEIGHT	C=292303	-
⚠ 1		CUSTOMER DRAWING	SCALE	SHEET
⚠ 2			5:1	2 of 5
			REV	G

REVISIONS					
P	LTR	DESCRIPTION	DATE	DWN	APVD
-	-	SEE SHEET 1	-	-	-

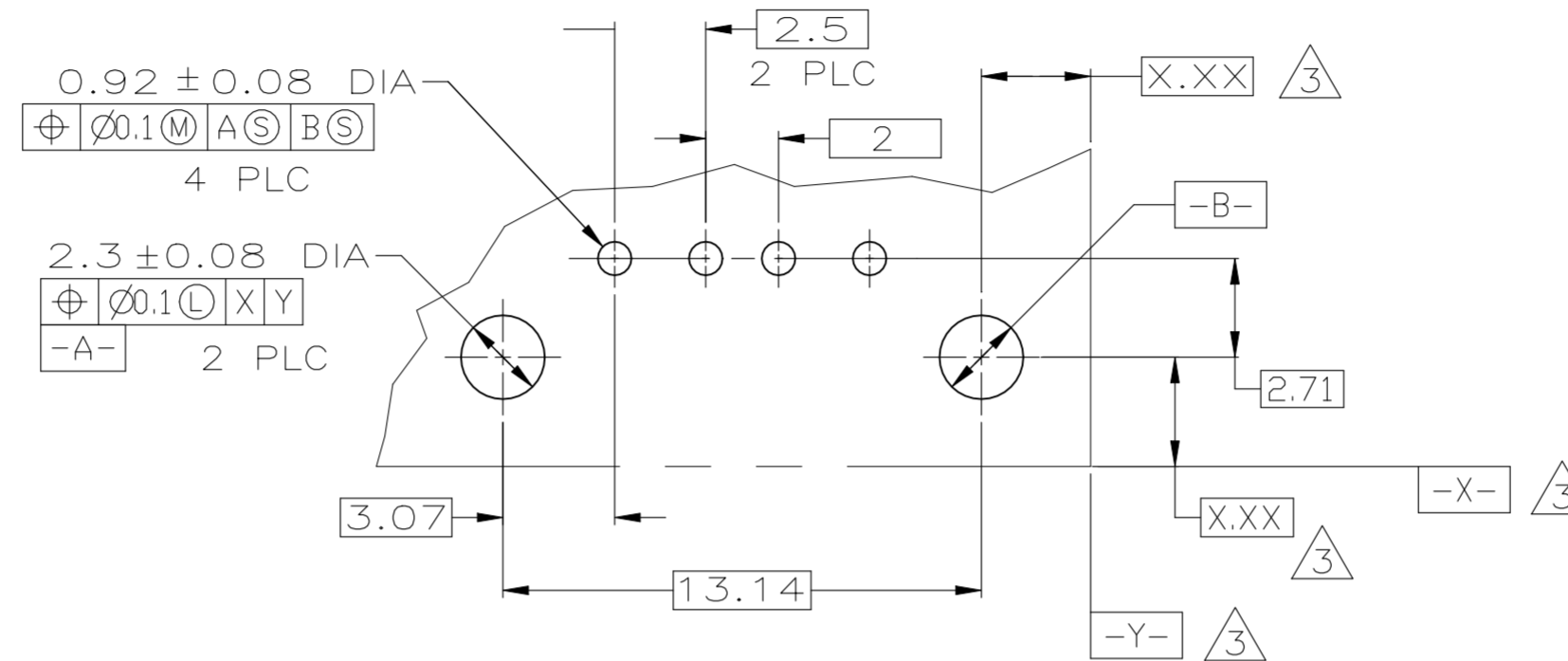
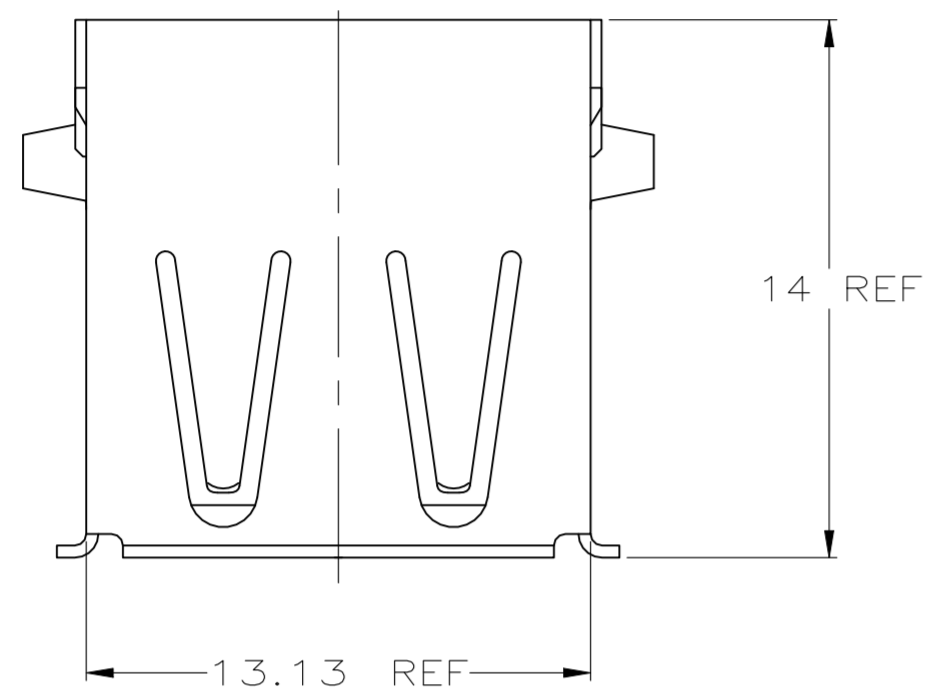

PC BOARD MOUNTING DIMENSIONS 4

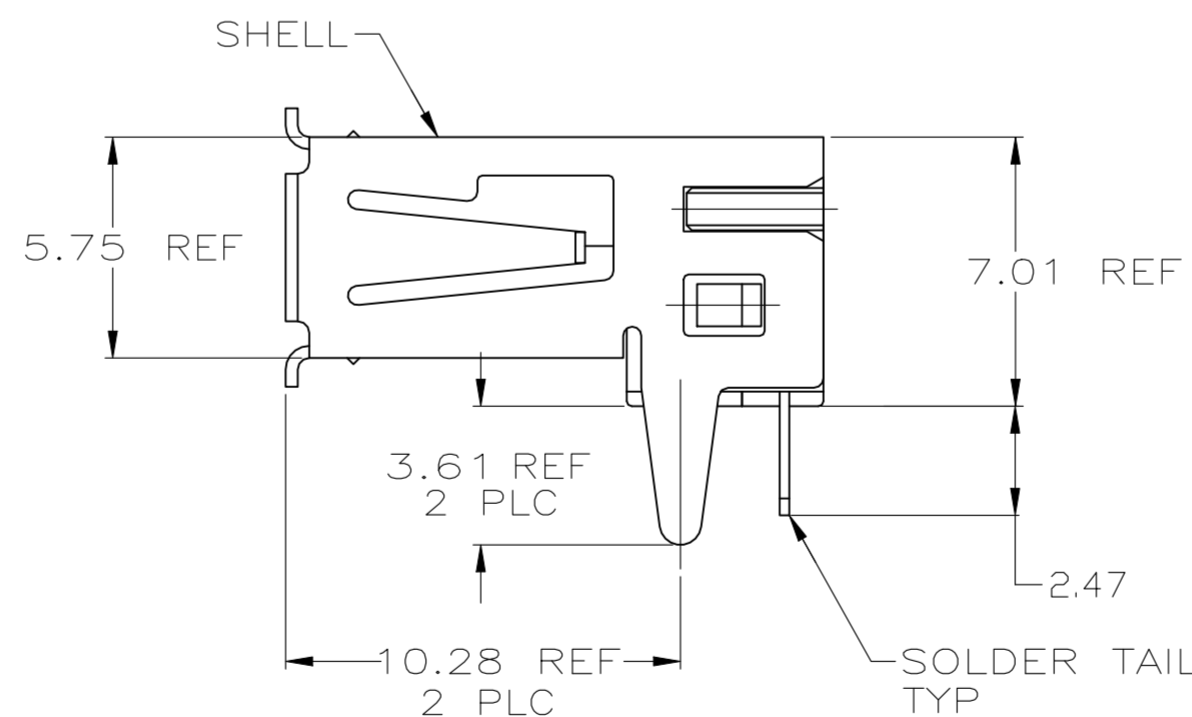
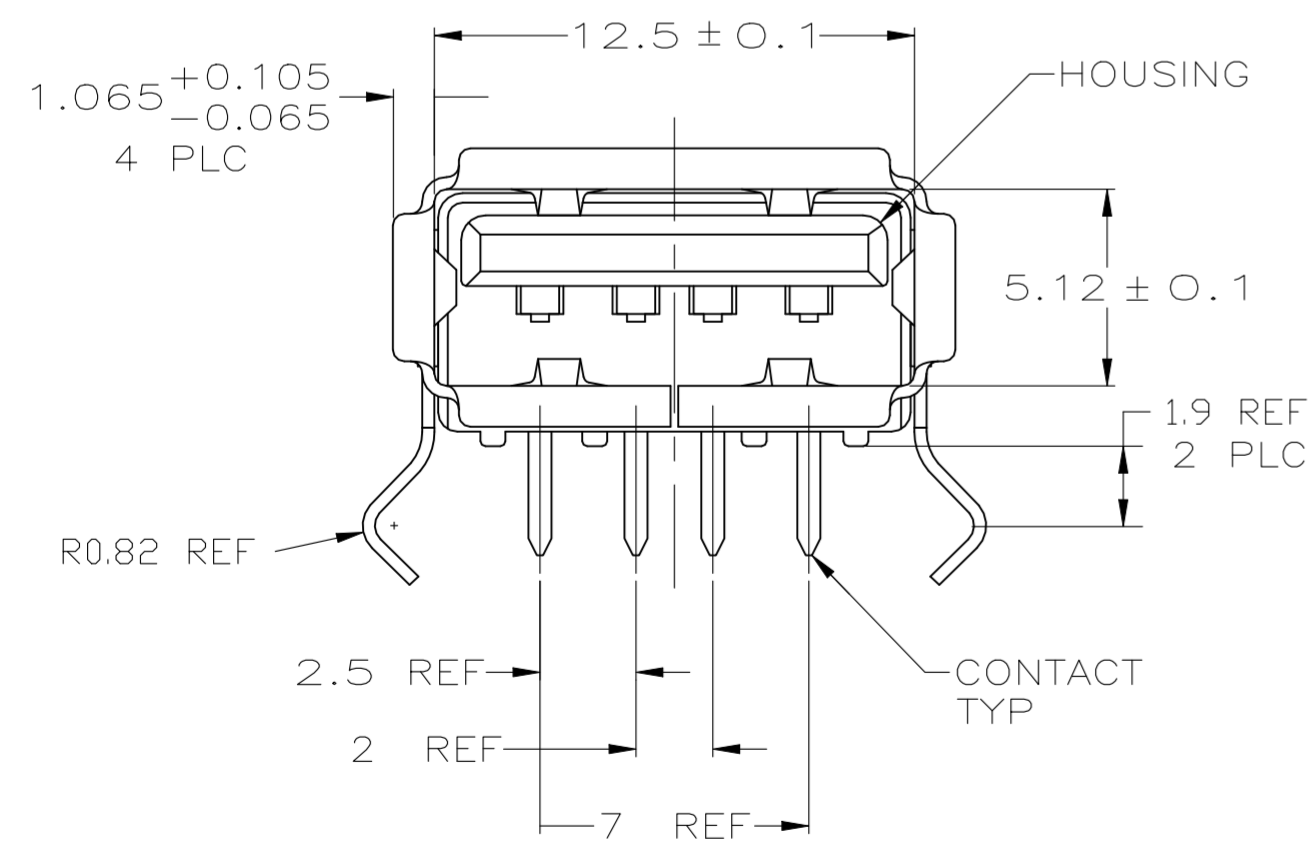

- 1 MATERIAL:
SHELL:- STAINLESS STEEL & CONTACTS- COPPER ALLOY.
HOUSING: UL 94V-0 RATED, THERMOPLASTIC, COLOR SEE TABLE.
- 2 PLATING:
CONTACTS: 0.076 μm MINIMUM GOLD OVER 0.76 μm MINIMUM PALLADIUM-NICKEL ON MATING AREA.
3.8 μm MINIMUM MATTE TIN ON SOLDER TAILS.
BOTH OVER 1.27 μm MINIMUM NICKEL.
CONTACT ALTERNATE PLATING: 0.76 μm MIN GOLD ON MATING AREA, 3.80 μm MIN MATTE TIN ON SOLDER TAILS, BOTH OVER 1.27 μm MIN NICKEL.
SHELL: 2~5 μm MINIMUM BRIGHT TIN
- 3 DATUM AND BASIC DIMENSIONS ESTABLISHED BY CUSTOMER.
- 4 RECOMMENDED PC BOARD THICKNESS OF 1.2.

NO	NATURAL	292303-8
HIGH TEMPERATURE COMPATIBLE	HOUSING COLOR	PART NUMBER
DWN J.JIANG 19FEB04 CHK S.YAO 19FEB04 APVD T.SASAKI 19FEB04 PRODUCT SPEC 108-60034 APPLICATION SPEC -		TE TE Connectivity Ltd. RECEPTACLE ASSEMBLY RIGHT ANGLE, 4 POSITION, T/H & SMT USB, LEAD FREE VERSION
SIZE	CAGE CODE	DRAWING NO
A2	00779	C=292303
CUSTOMER DRAWING		RESTRICTED TO -
SCALE	SHEET	REV
5:1	3 of 5	G

THIS DRAWING IS A CONTROLLED DOCUMENT.	
DIMENSIONS:	TOLERANCES UNLESS OTHERWISE SPECIFIED:
mm	
	0 PLC ± -
	1 PLC ± -
	2 PLC ± 0.25
	3 PLC ± -
	4 PLC ± -
	ANGLES ± -
MATERIAL	FINISH
1	2

REVISIONS					
P	LTR	DESCRIPTION	DATE	DWN	APVD
-	-	SEE SHEET 1	-	-	-

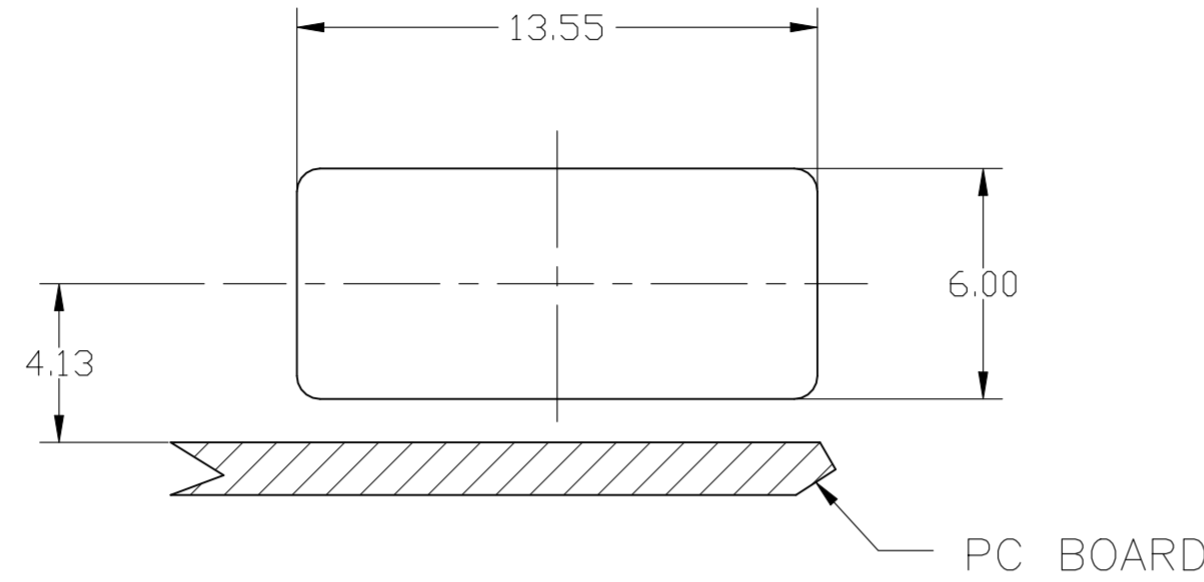
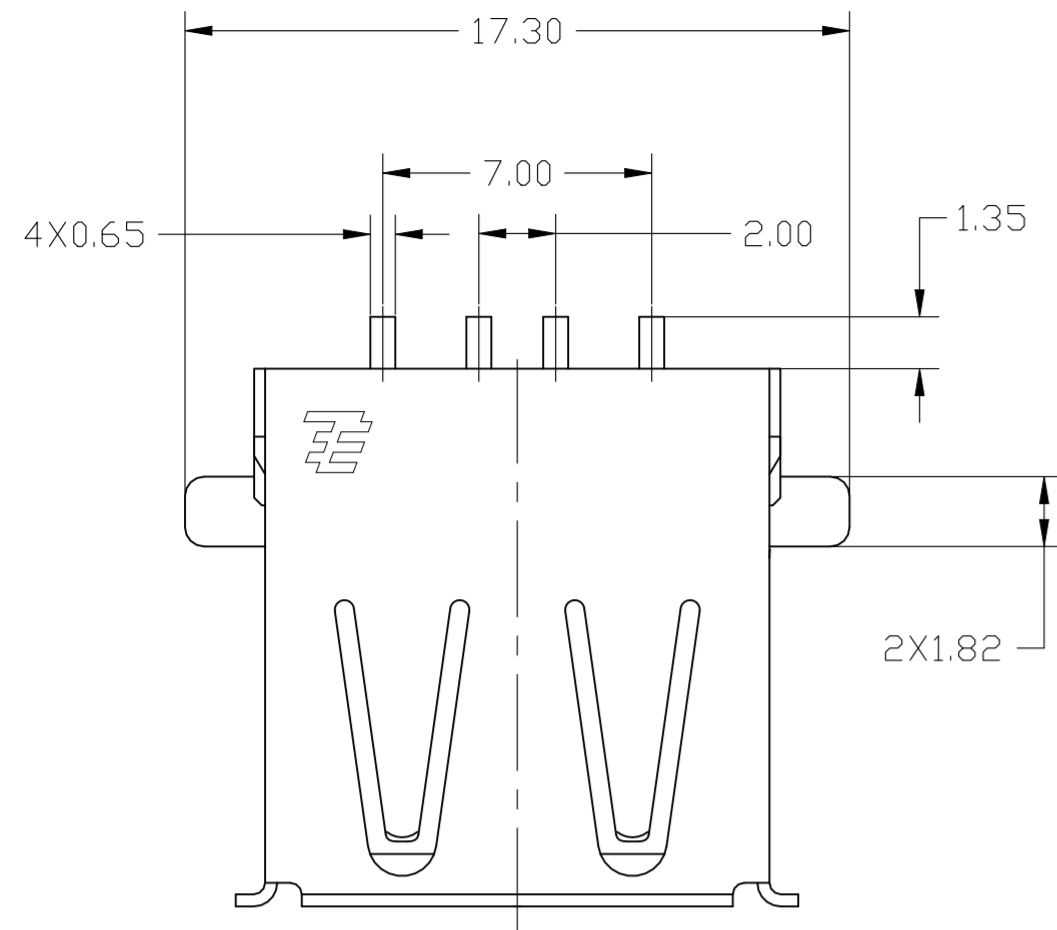

RECOMMENDED MOUNTING PANEL CUTOUT

- ⚠ MATERIAL:
SHELL:- STAINLESS STEEL & CONTACTS- COPPER ALLOY.
HOUSING: UL 94V-0 RATED, THERMOPLASTIC, COLOR SEE TABLE.
- ⚠ PLATING:
CONTACTS: 0.076 μm MINIMUM GOLD OVER 0.76 μm MINIMUM PALLADIUM-NICKEL ON MATING AREA.
3.8 μm MINIMUM MATTE TIN ON SOLDER TAILS.
BOTH OVER 1.27 μm MINIMUM NICKEL.
CONTACT ALTERNATE PLATING: 0.76 μm MIN GOLD ON MATING AREA, 3.80 μm MIN MATTE TIN ON SOLDER TAILS, BOTH OVER 1.27 μm MIN NICKEL.
SHELL: 2~5 μm MINIMUM BRIGHT TIN
- ⚠ PANEL IS NEEDED FOR CUSTOMER.

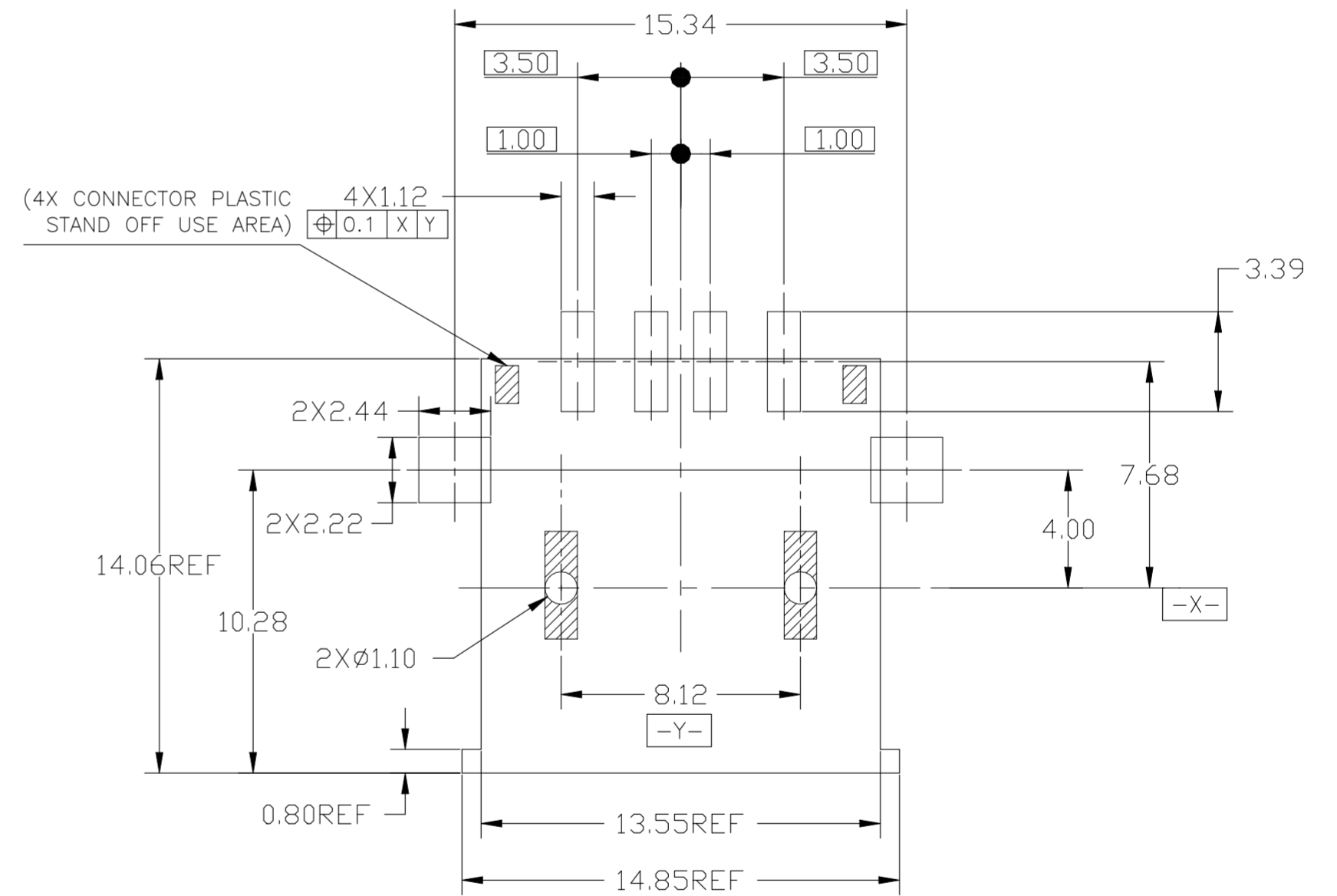
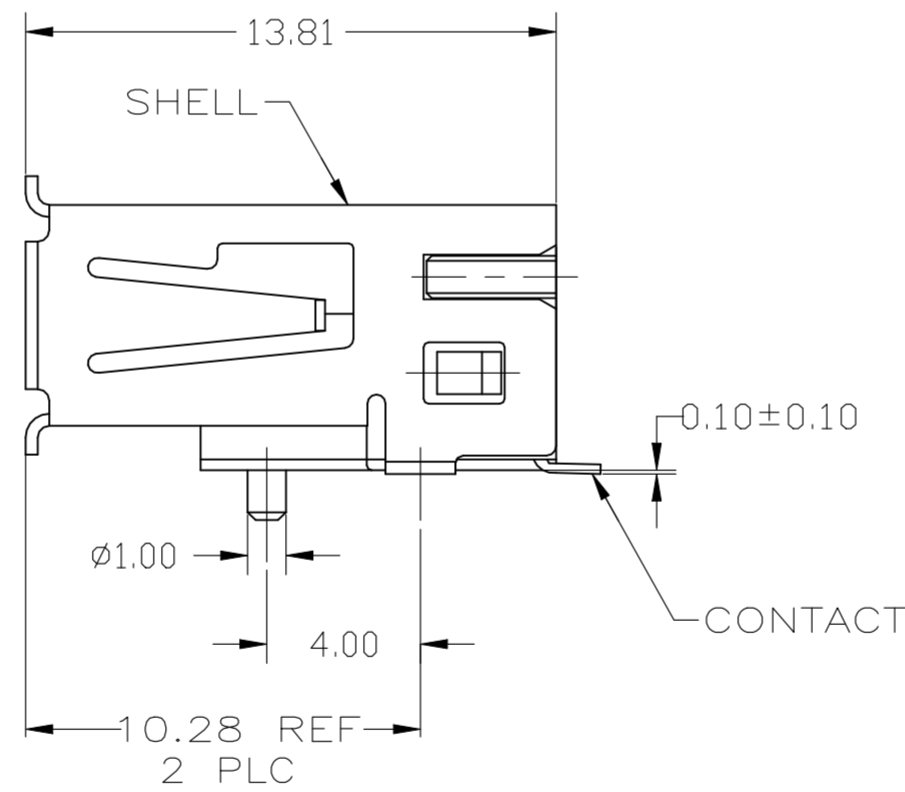
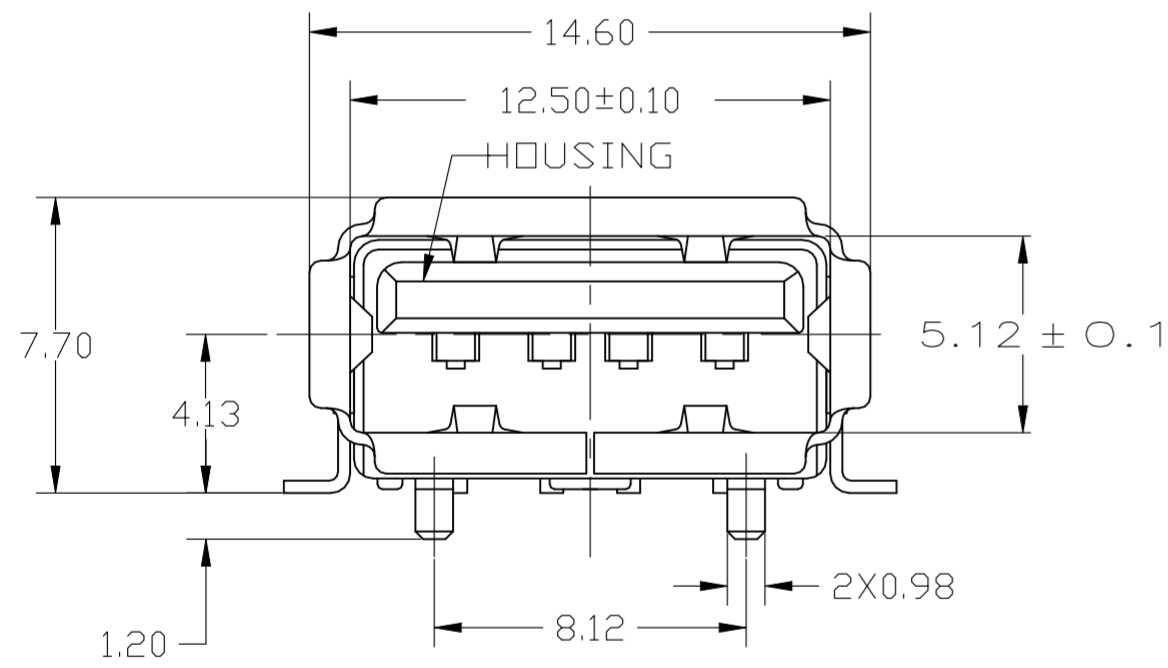

RECOMMENDED PC BOARD MOUNTING LAYOUT (TOLERANCE=±0.05)

THIS DRAWING IS A CONTROLLED DOCUMENT.		DWN J.JIANG 19FEB04	TE Connectivity Ltd.	
		CHK S.YAO 19FEB04		
DIMENSIONS: mm		APVD T.SASAKI 19FEB04	NAME RECEPTACLE ASSEMBLY RIGHT ANGLE, 4 POSITION, T/H & SMT USB, LEAD FREE VERSION	
TOLERANCES UNLESS OTHERWISE SPECIFIED:		PRODUCT SPEC 108-60034	SIZE A2	
0 PLC ± -		APPLICATION SPEC	CAGE CODE 00779	DRAWING NO C=292303
1 PLC ± -			RESTRICTED TO	
2 PLC ± 0.25				
3 PLC ± -				
4 PLC ± -				
ANGLES ± -				
MATERIAL ⚠	FINISH ⚠	WEIGHT -	SCALE 5:1	
HIGH TEMPERATURE COMPATIBLE		CUSTOMER DRAWING		SHEET 4 of 5
BLACK 1-292303-6				REV G
NATURAL 292303-9				
HOUSING COLOR				
PART NUMBER				

YES	BLACK	1-292303-6
YES	NATURAL	292303-9
HIGH TEMPERATURE COMPATIBLE	HOUSING COLOR	PART NUMBER

4 3 2 1

© - TE Connectivity. All Rights Reserved.

REVISIONS					
P	LTR	DESCRIPTION	DATE	DWN	APVD
-	-	SEE SHEET 1	-	-	-

1 MATERIAL:
SHELL: STAINLESS STEEL & CONTACTS- COPPER ALLOY.
HOUSING: UL 94V-0 RATED, THERMOPLASTIC, COLOR SEE TABLE.

2 PLATING:
CONTACTS: 0.076μm MINIMUM GOLD OVER 0.76μm MINIMUM PALLADIUM-NICKEL ON MATING AREA.
3.8μm MINIMUM MATTE TIN ON SOLDER TAILS.
BOTH OVER 1.27μm MINIMUM NICKEL.
CONTACT ALTERNATE PLATING: 0.76μm MIN GOLD ON MATING AREA, 3.80μm MIN MATTE TIN ON SOLDER TAILS, BOTH OVER 1.27μm MIN NICKEL.
SHELL: MINIMUM BRIGHT TIN OVER MIN NICKEL.

3 DATUM AND BASIC DIMENSIONS ESTABLISHED BY CUSTOMER.

4 RECOMMENDED PC BOARD THICKNESS OF 1.57 mm.

PC BOARD MOUNTING DIMENSIONS 4

OBSOLETE

OB	YES	BLACK	2-292303-1
	HIGH TEMPERATURE COMPATIBLE	HOUSING COLOR	PART NUMBER

THIS DRAWING IS A CONTROLLED DOCUMENT.		DWN J.JIANG 19FEB04	TE Connectivity Ltd.	
DIMENSIONS: mm		CHK S.YAO 19FEB04		
TOLERANCES UNLESS OTHERWISE SPECIFIED:		APVD T.SASAKI 19FEB04	NAME	
0 PLC ± -		PRODUCT SPEC	RECEPTACLE ASSEMBLY RIGHT	
1 PLC ± -		APPLICATION SPEC	ANGLE, 4 POSITION, T/H & SMT	
2 PLC ± 0.25		108-60034	USB, LEAD FREE VERSION	
3 PLC ± -			SIZE	CAGE CODE
4 PLC ± -			A2	00779
ANGLES ± -			DRAWING NO	RESTRICTED TO
FINISH		WEIGHT	C=292303	-
MATERIAL		CUSTOMER DRAWING	SCALE 5:1	SHEET 5 of 5
			REV G	

1471-9 (1/15)