

Silicon Standard Recovery Diode

$V_{RRM} = 1600\text{ V} - 2000\text{ V}$
 $I_F = 300\text{ A}$

Features

- High Surge Capability
- Types from 1600 V to 2000 V V_{RRM}
- Not ESD Sensitive

Note:

1. Standard polarity: Stud is cathode.
2. Reverse polarity (R): Stud is anode.
3. Stud is base.

DO-9 Package

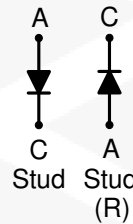

Maximum ratings, at $T_j = 25\text{ }^\circ\text{C}$, unless otherwise specified ("R" devices have leads reversed)

Parameter	Symbol	Conditions	S300Y (R)	S300Z (R)	Unit
Repetitive peak reverse voltage	V_{RRM}		1600	2000	V
RMS reverse voltage	V_{RMS}		1131	1414	V
DC blocking voltage	V_{DC}		1600	2000	V
Continuous forward current	I_F	$T_C \leq 130\text{ }^\circ\text{C}$	300	300	A
Surge non-repetitive forward current, Half Sine Wave	$I_{F,SM}$	$T_C = 25\text{ }^\circ\text{C}$, $t_p = 8.3\text{ ms}$	6850	6850	A
Operating temperature	T_j		-55 to 150	-55 to 150	$^\circ\text{C}$
Storage temperature	T_{stg}		-55 to 150	-55 to 150	$^\circ\text{C}$

Electrical characteristics, at $T_j = 25\text{ }^\circ\text{C}$, unless otherwise specified

Parameter	Symbol	Conditions	S300Y (R)	S300Z (R)	Unit
Diode forward voltage	V_F	$I_F = 300\text{ A}$, $T_j = 25\text{ }^\circ\text{C}$	1.2	1.2	V
Reverse current	I_R	$V_R = 1600\text{ V}$, $T_j = 25\text{ }^\circ\text{C}$	10	10	μA
		$V_R = 1600\text{ V}$, $T_j = 175\text{ }^\circ\text{C}$	12	12	mA

Thermal characteristics

Thermal resistance, junction - case	R_{thJC}		0.16	0.16	$^\circ\text{C/W}$
-------------------------------------	------------	--	------	------	--------------------

Figure.1-Typical Forward Characteristics

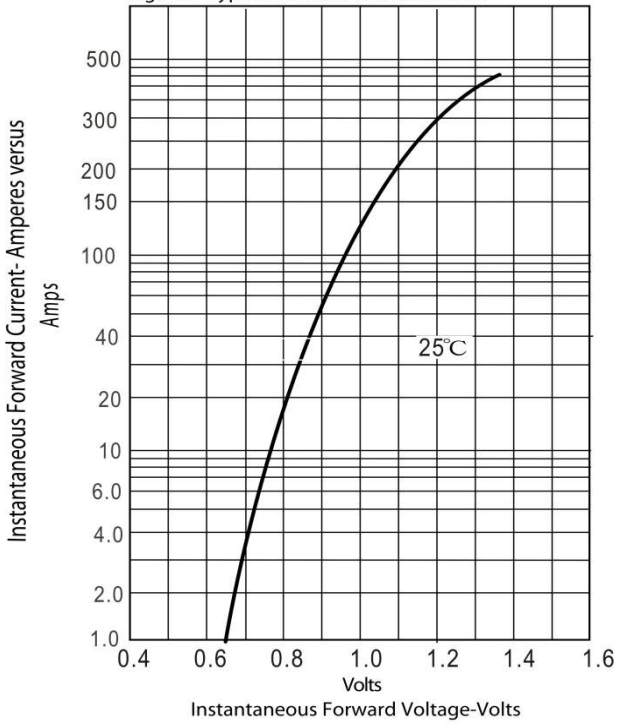

Figur.2-Forward Derating Curve

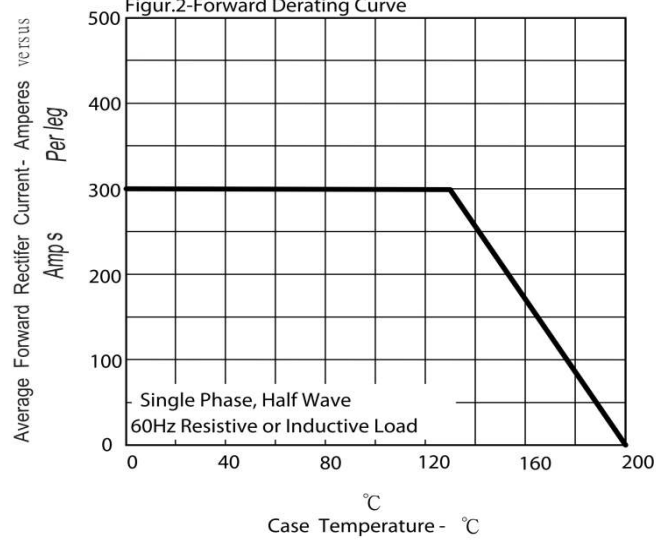
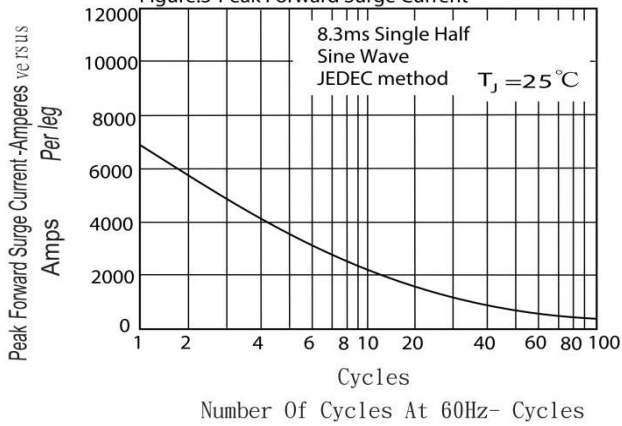
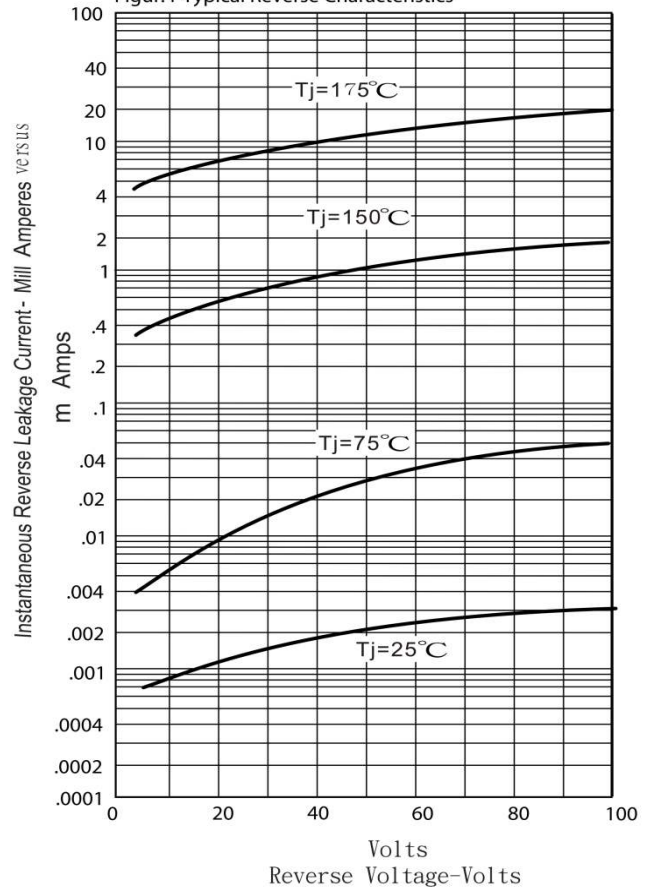

Figure.3-Peak Forward Surge Current



Figur.4-Typical Reverse Characteristics



Package dimensions and terminal configuration

Product is marked with part number and terminal configuration.

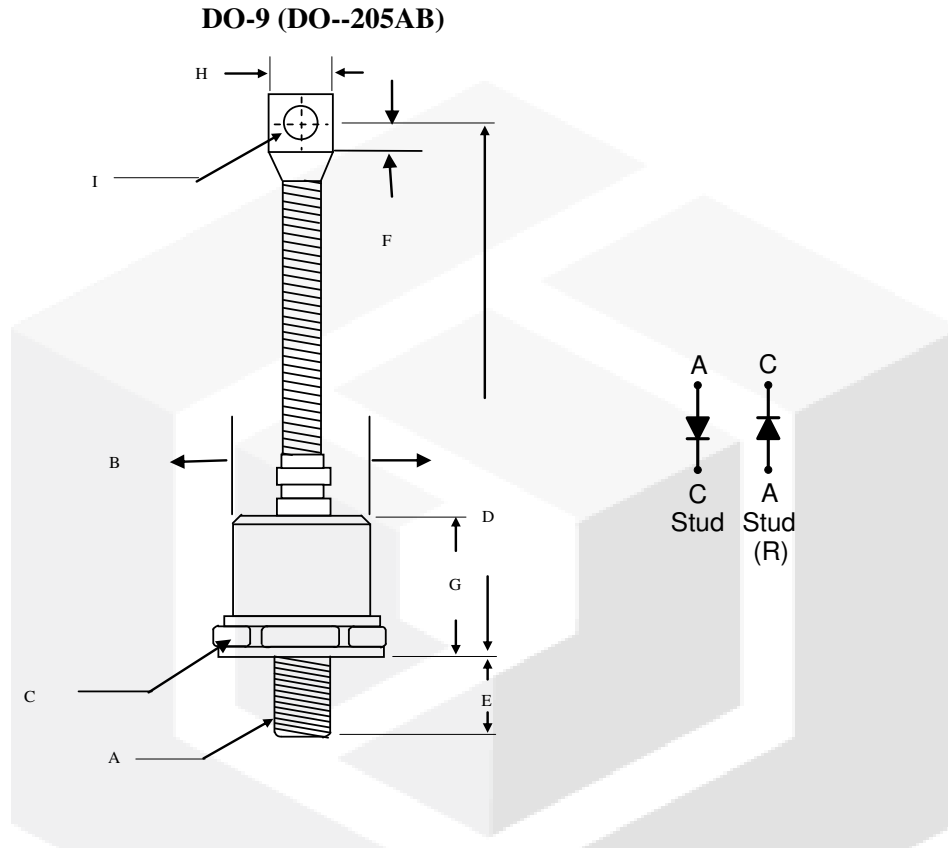

	Inches		Millimeters	
	Min	Max	Min	Max
A	3/4 - 16 UNF			
B	----	1.10	----	27.94
C	1.24	1.25	31.5	31.90
D	----	7.48	----	190.0
E	0.78	0.828	19.60	21.03
F	0.470	0.530	11.94	13.46
G	----	1.122	----	28.5
H	----	0.787	----	20.0
I	0.330	0.350	8.38	8.89