

POSITIONS/ CONTACTS	A		B	
	INCH	MM	INCH	MM
02/04	0.100	2.54	0.220	5.58
03/06	0.200	5.08	0.320	8.12
04/08	0.300	7.62	0.420	10.66
05/10	0.400	10.16	0.520	13.20
06/12	0.500	12.70	0.620	15.74
07/14	0.600	15.24	0.720	18.28
08/16	0.700	17.78	0.820	20.82
09/18	0.800	20.32	0.920	23.36
10/20	0.900	22.86	1.020	25.90
11/22	1.000	25.40	1.120	28.44
12/24	1.100	27.94	1.220	30.98
13/26	1.200	30.48	1.320	33.52
14/28	1.300	33.02	1.420	36.06
15/30	1.400	35.56	1.520	38.60
16/32	1.500	38.10	1.620	41.14
17/34	1.600	40.64	1.720	43.68
18/36	1.700	43.18	1.820	46.22
19/38	1.800	45.72	1.920	48.76
20/40	1.900	48.26	2.020	51.30
21/42	2.000	50.80	2.120	53.84
22/44	2.100	53.34	2.220	56.38
23/46	2.200	55.88	2.320	58.92
24/48	2.300	58.42	2.420	61.46
25/50	2.400	60.96	2.520	64.00
26/52	2.500	63.50	2.620	66.54
27/54	2.600	66.04	2.720	69.08
28/56	2.700	68.58	2.820	71.62
29/58	2.800	71.12	2.920	74.16
30/60	2.900	73.66	3.020	76.70
31/62	3.000	76.20	3.120	79.24
32/64	3.100	78.74	3.220	81.78
33/66	3.200	81.28	3.320	84.32
34/68	3.300	83.82	3.420	86.86
35/70	3.400	86.36	3.520	89.40
36/72	3.500	88.90	3.620	91.94
37/74	3.600	91.44	3.720	94.48
38/76	3.700	93.98	3.820	97.02
39/78	3.800	96.52	3.920	99.56
40/80	3.900	99.06	4.020	102.10

PART NUMBER CODING

xPxCxx2LJBN-RC

- NUMBER OF POSITIONS**
(CONTACTS PER ROW, 02 THRU 40)
- PLATING**
(.000030"~.000050" NICKEL UNDERPLATED)
P = GOLD FLASH OVERALL
T = TIN OVERALL
- INSULATOR MATERIAL**
P = POLYESTER, UL 94V-0.
PROCESSING TEMP. = WAVE / MANUAL SOLDERING ONLY
N = NYLON 9T, UL 94V-0.
PROCESSING TEMP. = 260°C MAX FOR 10 SECONDS

REVISIONS				
REV.	ECO. NO	DESCRIPTION	DATE	BY
J	3900	UPDATE RAB TAIL-TO-RAB TAIL DIM TOLERANCE FOR POSI 35 TO POSI 40 (WAS ±.008), ADD DIM A ON MATING SIDE, UPDATE TOL FOR TAIL LENGTH, 1ST RAB DISTANCE (±.010 WAS ±.008) & PITCH DIM TOL	8/22/2018	JH/LH
K	3963	UPDATE GENERAL TOL IN TITLE BOX, NOTE 8 & WARP TOL, UPGRADE NYLON MTL (FROM 6T TO 9T), UPDATE TAIL-TO-TAIL, TAIL PITCH & TAIL ROW SPACING DIM TO REF	1/3/2019	JH

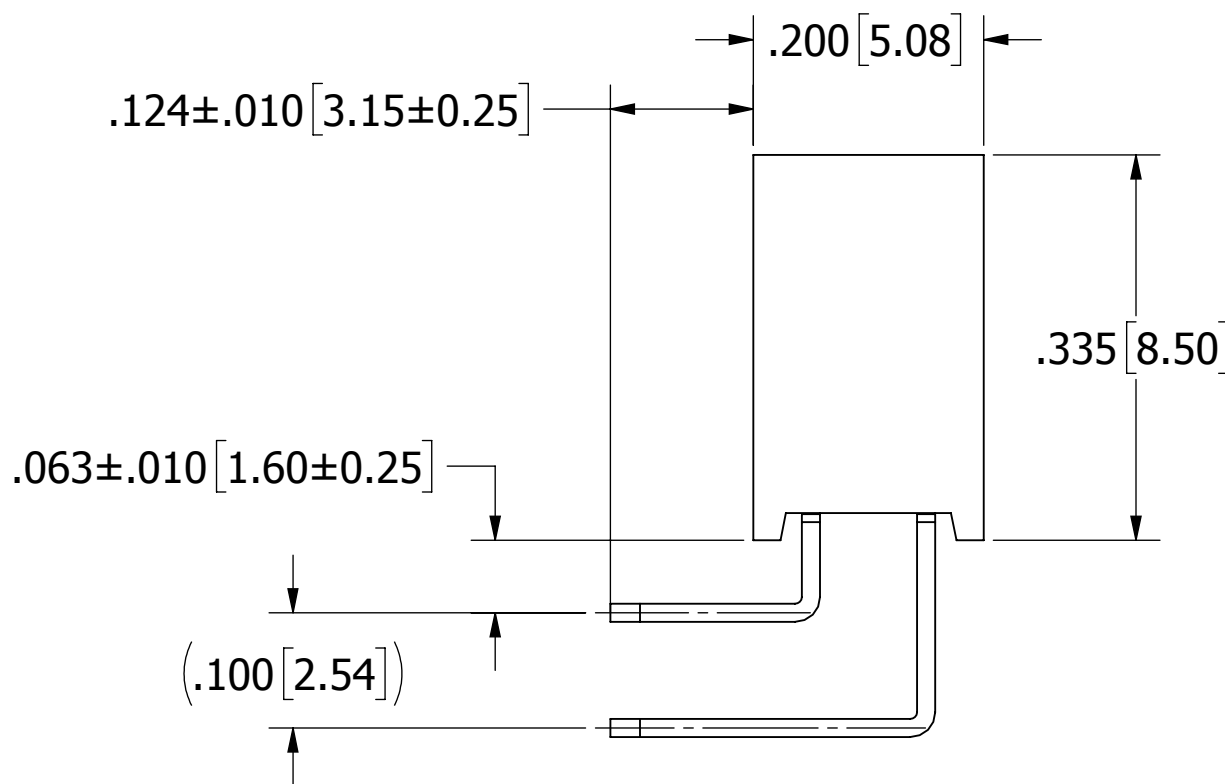
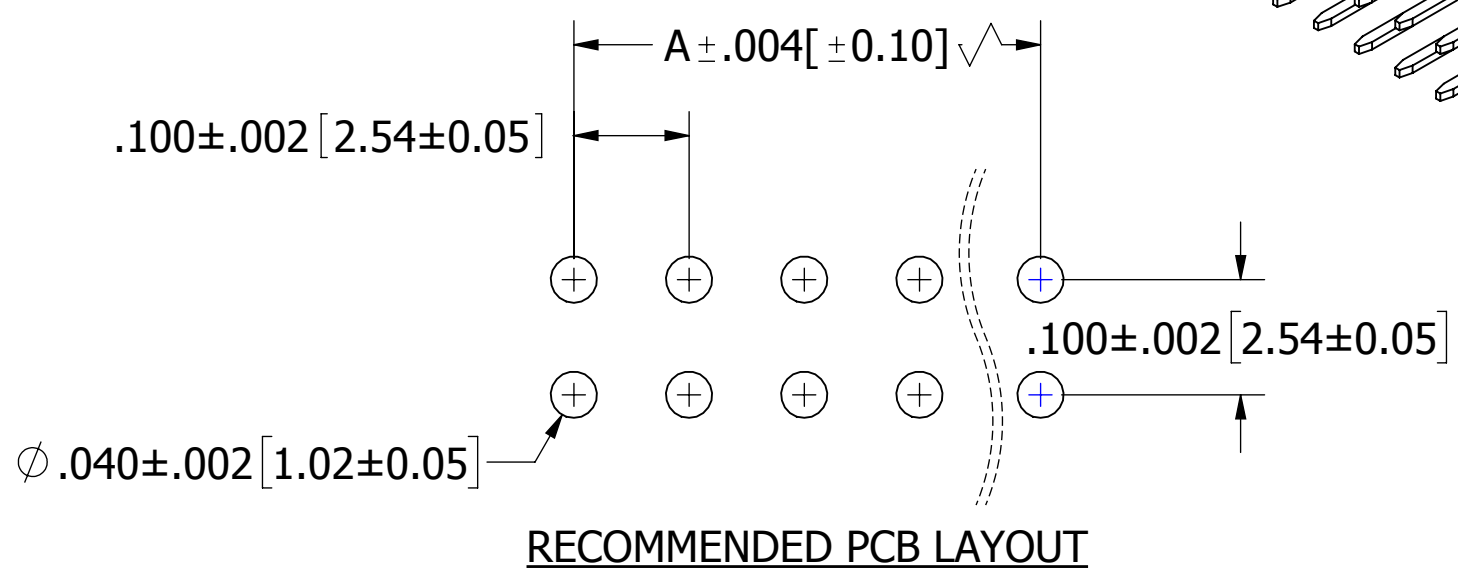
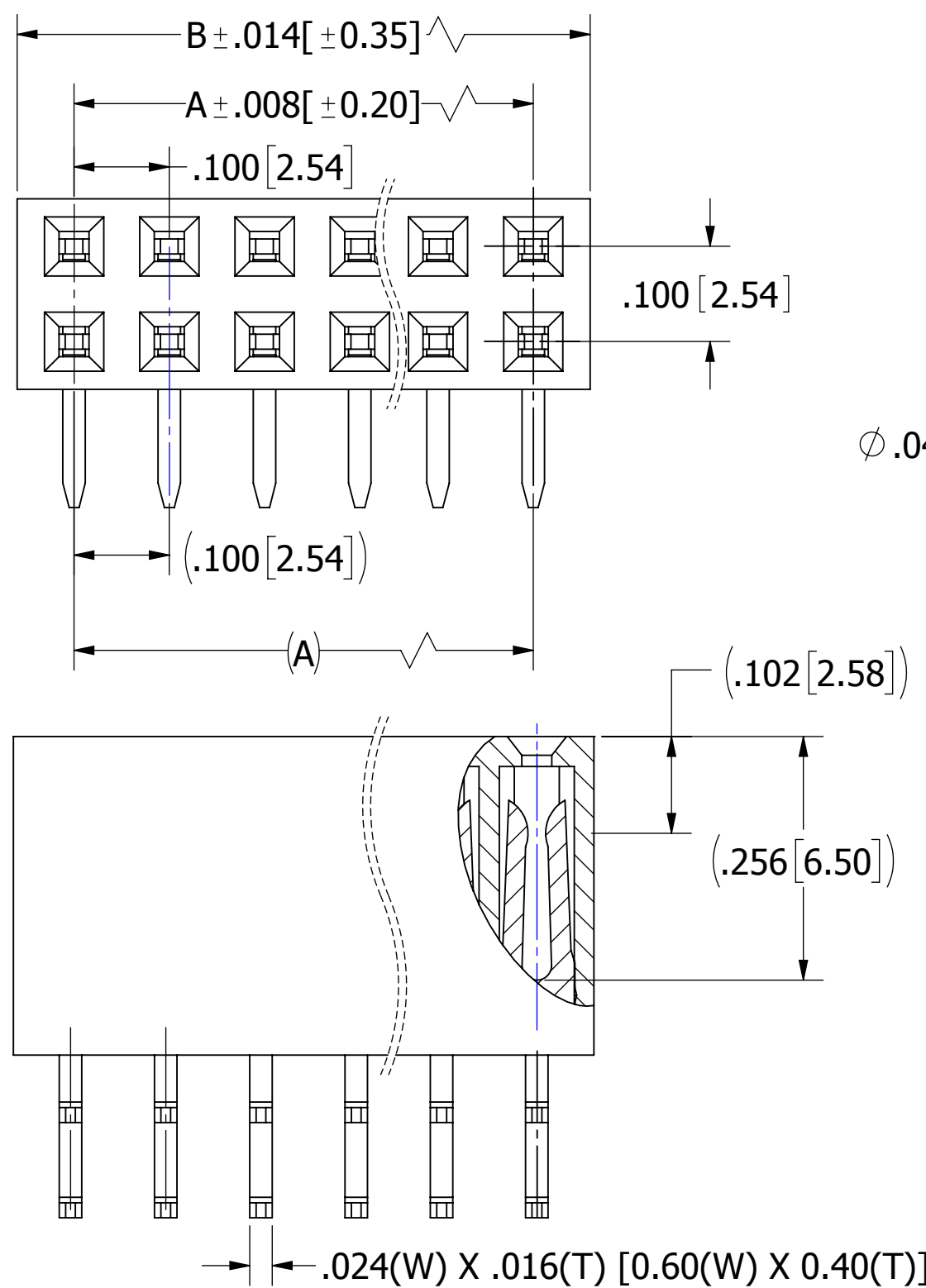
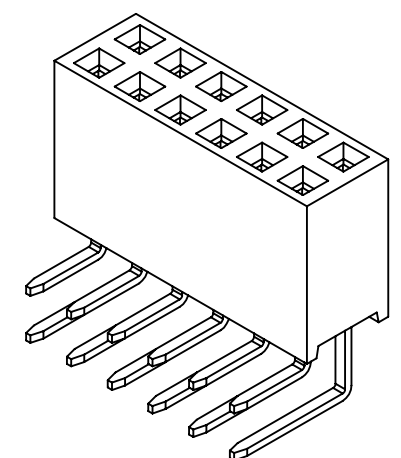

02-15, .008[0.20] MAX.
16-30, .012[0.30] MAX.
31-40, .016[0.40] MAX.

- NOTES:**
- INSULATOR MATERIAL: SEE PART NUMBER CODING.
 - CONTACT MATERIAL: PHOSPHOR BRONZE.
 - CONTACT PLATING: SEE PART NUMBER CODING.
 - CURRENT RATING: 3 AMPS
 - VOLTAGE RATING: 250 VAC
 - INSULATOR RESISTANCE: 5000 MEGOHMS MIN.
 - CONTACT RESISTANCE: 20 MILLIOHMS MAX.
 - DIELECTRIC WITHSTANDING: 1000 VAC.
 - OPERATING TEMPERATURE: -40° C TO +105° C.
 - MATES WITH SULLINS .100 [2.54] CONTACT CENTER MALE HEADER SERIES. (.025 [0.64] SQUARE POSTS)



UNLESS OTHERWISE SPECIFIED: DIMENSIONS ARE IN INCHES [MM]		DRAWN	DATE	NAME	
			2/15/2008	JH	
TOLERANCES: ANGULAR: ± 5° DECIMALS .XX = ± .012 [.3] .XXX = ± .008 [.20] .XXXX = ± .0039 [.100]					<small>THE INFORMATION HEREIN CONTAINS PROPRIETARY INFORMATION OF SULLINS ELECTRONICS AND IS NOT TO BE REPRODUCED, USED OR DISCLOSED TO OTHERS FOR ANY PURPOSE EXCEPT AS SPECIFICALLY AUTHORIZED IN WRITING BY AN OFFICER OF SULLINS ELECTRONICS.</small>
TITLE					HEADER FEMALE, .100" [2.54mm] CC, 2 ROW, RA
PART NUMBER					xPxCxx2LJBN-RC
SIZE	CAGE CODE	DWG. NO.	REV		
C	54453	10494	K		
SCALE: 6:1		SHEET 1 OF 1			