

Verpackt im Gurt in Anlehnung an DIN IEC 60286-3
 Tape on Reel Packaging according to DIN IEC 60286-3
 Verpackungseinheit: 500 Stück
 Packaging unit: 500 pcs

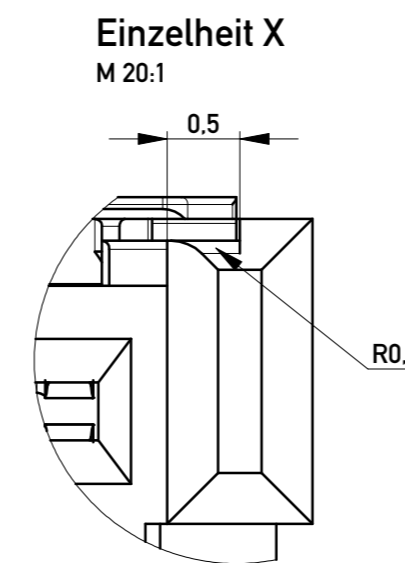

Abspulrichtung - Reel off Direction

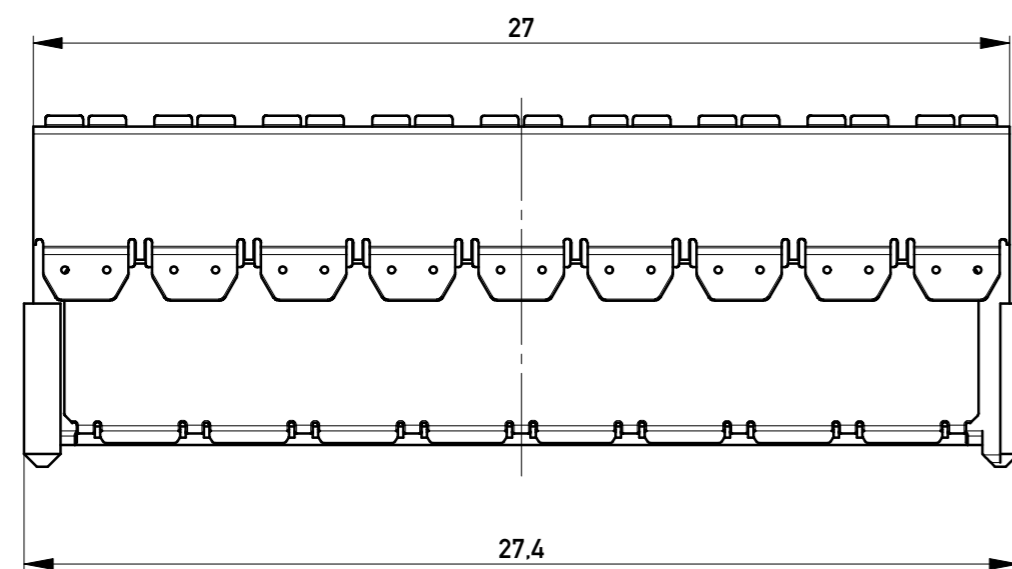
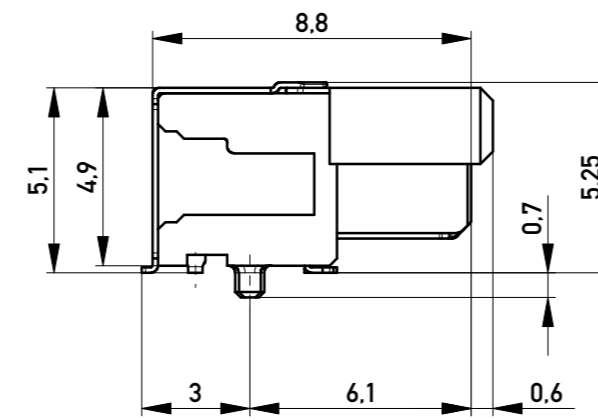
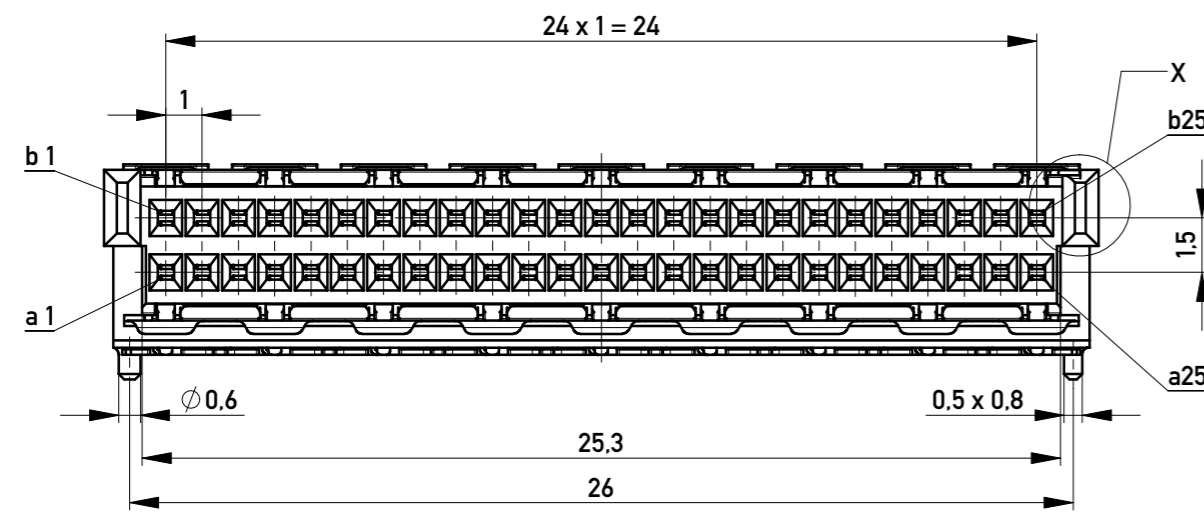
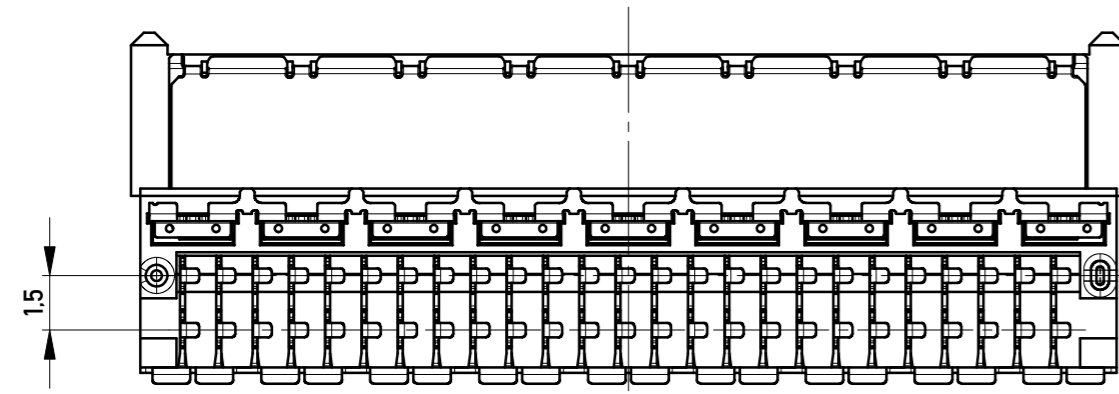
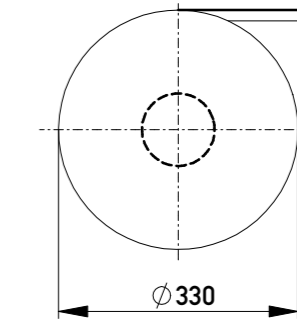
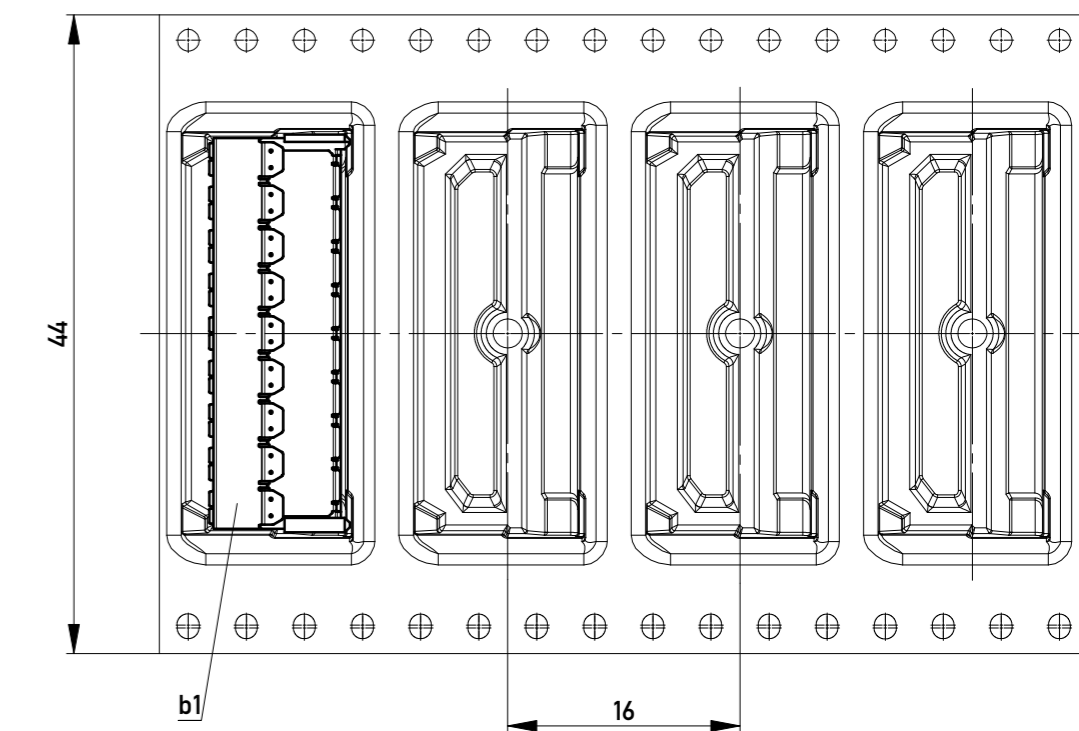

Leiterplatten-Layout Vorschlag / PCB-Layout Proposal

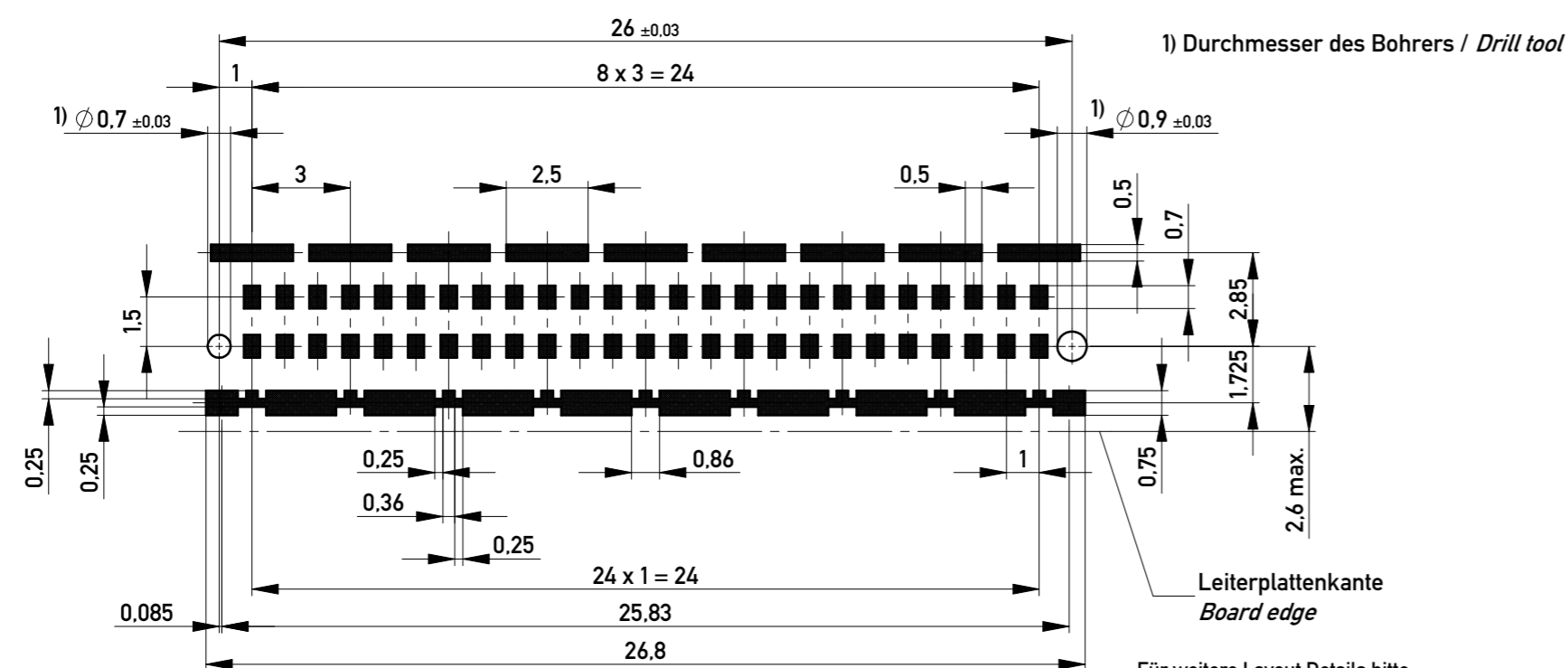

Leiterplattenkante
Board edge

Für weitere Layout Details bitte
 Applikations Schrift MicroSpeed beachten.
 For further layout details please consider
 MicroSpeed application note.

Anforderungsstufe 1
Performance Level 1

Kontaktbereich vergoldet
Mating Area gold plating

Anschlussbereich verzinkt 4-6 µm
Terminal Area 4-6 µm tin plating

Koplanarität der Anschlüsse ≤ 0.1 mm
Coplanarity Area of Termination ≤ 0.1 mm

Information:	Tolerances	Scale 5:1	
All rights reserved. Only for Information. To ensure that this is the latest version of this drawing, please contact one of the ERNI companies before using.	Subject to modification without prior notice. Drawing will not be updated.	All Dimensions in mm	Designation
			Federl. 90° 50p. BM SMD EMV Female 90° 50 c. BM SMD EMV
h	06.09.2016	www.ERNI.com	284310
Index	Date	Class	MSPEED

Copyright by ERNI Production GmbH & Co. KG
 Proprietary notice pursuant to ISO 10012 to be observed.