

REVISIONS					
REV	DESCRIPTION	ECO	DATE	DWN	APVD
A1	Corrected material spec		8/10/2011	BB	AR

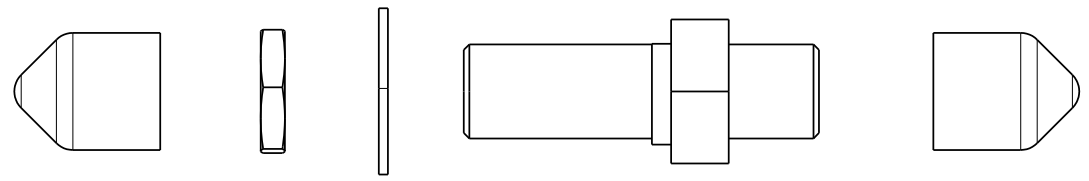
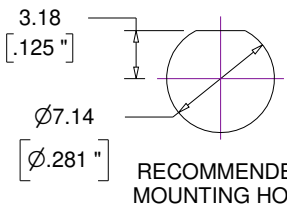
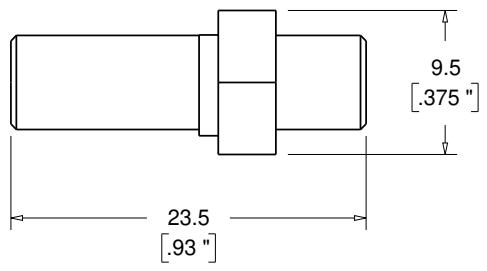
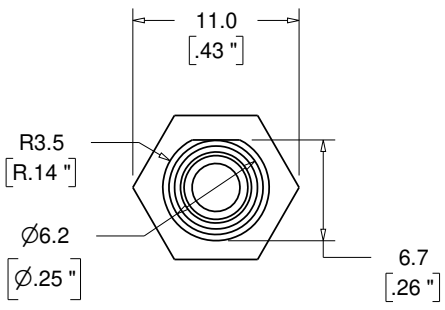

INCLUDES 8mm HEX NUT, LOCK WASHER AND TWO (2) DUST CAPS

UNLESS OTHERWISE SPECIFIED	
DIMENSIONS MILLIMETERS [IN.]	
TOLERANCES	SURFACE TEXTURE: 3.2 ✓
0 PLC: ± 1	
1 PLC: ± .25	
2 PLC: ± .127	
3 PLC: ± .025	
4 PLC: ± .013	
ANGLE: ± 1/2°	
REMOVE BURRS AND SHARP EDGES	
FLATNESS .005mm PER mm	
ALL DIMENSIONS AFTER FINISH	

PRODUCT	IF 820064
MATERIAL	Brass
FINISH	Nickel Plated
DRAWN BY	B. Bidwell
DATE	1/6/2010
CHECKED BY	A. Reyes
DATE	1/6/2010

Industrial Fiber Optics TEMPE, AZ 85281			
NAME SMA Mating Sleeve			
SIZE A	SCALE 2:1	PART NUMBER 820064	REV A1
DO NOT SCALE DRAWING		Sheet 1 of 1	

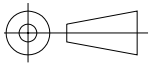

METRIC

