

12	11	10	9	8	7	6	5	4	3	2	1					
UNPLATED MATERIAL NUMBER	UNPLATED ENG. NUMBER	UNPLATED MAT'L NO. ON TAPE	UNPLATED ENG. NO. ON TAPE	PLATED MATERIAL NUMBER	PLATED ENGINEERING NUMBER	PLATED MAT. NO. ON TAPE	PLATED ENG. NO ON TAPE	SEE DETAIL	STUD SIZE	WIRE RANGE	"S" ±.015/0.38	"L" ±.050/1.27	"W" ±.035/0.89	"C" ±.050/1.27	"B" ±.020/0.51	"T" ±.030/0.76
192210451	BCL-410	190820044	BCL-410T	192210452	BCL-410-PL	190820048	BCL-410-PLT	D	10/4.8mm	4 AWG/25mm ²	.214/5.45	1.500/38.10	.531/13.49	.429/10.90	.286/7.26	.080/2.03
192210404	BCL-414	190820045	BCL-414T	192210230	BCL-414-PL	190820049	BCL-414-PLT	D	1/4"/M6	4 AWG/25mm ²	.278/7.06	1.500/38.10	.531/13.49	.429/10.90	.286/7.26	.080/2.03
192210405	BCL-4516	190820046	BCL-4516T	192210231	BCL-4516-PL	190820025	BCL-4516-PLT	D	5/16"/M8	4 AWG/25mm ²	.340/8.64	1.500/38.10	.531/13.49	.429/10.90	.286/7.26	.080/2.03
192210461	BCL-4516-WP	190820050	BCL-4516-WPT	192210460	BCL-4516-WP-PL	190820052	BCL-4516-WP-PLT	D	5/16"/M8	4 AWG/25mm ²	.340/8.64	1.531/38.89	.625/15.88	.397/10.08	.286/7.26	.080/2.03
192210383	BCL-438	190820047	BCL-438T	192210232	BCL-438-PL	190820026	BCL-438-PLT	D	3/8"/M9	4 AWG/25mm ²	.400/10.16	1.500/38.10	.531/13.49	.429/10.90	.286/7.26	.080/2.03
192210458	BCL-438-WP	190820051	BCL-438-WPT	192210456	BCL-438-WP-PL	190820027	BCL-438-WP-PLT	D	3/8"/M9	4 AWG/25mm ²	.400/10.16	1.531/38.89	.625/15.88	.397/10.08	.286/7.26	.080/2.03
192210459	BCL-438-XWP	D-----	-----	192210457	BCL-438-XWP-PL	D-----	-----	---	3/8"/M9	4 AWG/25mm ²	.400/10.16	1.688/42.88	.766/19.46	.444/11.28	.286/7.26	.100/2.54
192210453	BCL-412-XWP	D-----	-----	192210454	BCL-412-XWP-PL	D-----	-----	---	1/2"/M12	4 AWG/25mm ²	.520/13.21	1.688/42.88	.766/19.46	.444/11.28	.286/7.26	.100/2.54
192210419	BCL-214	190820057	BCL-214T	192210418	BCL-214-PL	190820001	BCL-214-PLT	C	1/4"/M6	2 AWG/35mm ²	.278/7.06	1.625/41.28	.625/15.88	.437/11.10	.336/8.53	.095/2.41
192210400	BCL-2516	190820058	BCL-2516T	192210233	BCL-2516-PL	190820002	BCL-2516-PLT	C	5/16"/M8	2 AWG/35mm ²	.340/8.64	1.625/41.28	.625/15.88	.437/11.10	.336/8.53	.095/2.41
192210380	BCL-238	190820059	BCL-238T	192210235	BCL-238-PL	190820030	BCL-238-PLT	C	3/8"/M9	2 AWG/35mm ²	.400/10.16	1.625/41.28	.625/15.88	.437/11.10	.336/8.53	.095/2.41
192210564	BCL-238-WP	D-----	-----	192210565	BCL-238-WP-PL	D-----	-----	---	3/8"/M9	2 AWG/35mm ²	.400/10.16	1.750/44.45	.750/19.05	.474/12.04	.336/8.53	.095/2.41
192210399	BCL-212-WP	D-----	-----	192210236	BCL-212-WP-PL	D-----	-----	---	1/2"/M12	2 AWG/35mm ²	.520/13.21	1.750/44.45	.750/19.05	.474/12.04	.336/8.53	.095/2.41
192210594	BCL-110	-----	-----	192210595	BCL-110-PL	-----	-----	---	10/4.8mm	1 AWG/50mm ²	.214/5.45	1.718/43.64	.656/16.66	.446/11.33	.360/9.14	.100/2.54
192210421	BCL-114	-----	-----	192210420	BCL-114-PL	-----	-----	---	1/4"/M6	1 AWG/50mm ²	.278/7.06	1.718/43.64	.656/16.66	.446/11.33	.360/9.14	.100/2.54
192210396	BCL-1516	-----	-----	192210237	BCL-1516-PL	-----	-----	---	5/16"/M8	1 AWG/50mm ²	.340/8.64	1.718/43.64	.656/16.66	.446/11.33	.360/9.14	.100/2.54
192210378	BCL-138	-----	-----	192210238	BCL-138-PL	-----	-----	---	3/8"/M9	1 AWG/50mm ²	.400/10.16	1.718/43.64	.656/16.66	.446/11.33	.360/9.14	.100/2.54
192210580	BCL-138-WP	-----	-----	192210581	BCL-138-WP-PL	-----	-----	---	3/8"/M9	1 AWG/50mm ²	.400/10.16	1.844/46.84	.750/19.05	.474/12.04	.360/9.14	.100/2.54
192210395	BCL-112	-----	-----	192210239	BCL-112-PL	-----	-----	---	1/2"/M12	1 AWG/50mm ²	.520/13.21	1.844/46.84	.750/19.05	.474/12.04	.360/9.14	.100/2.54

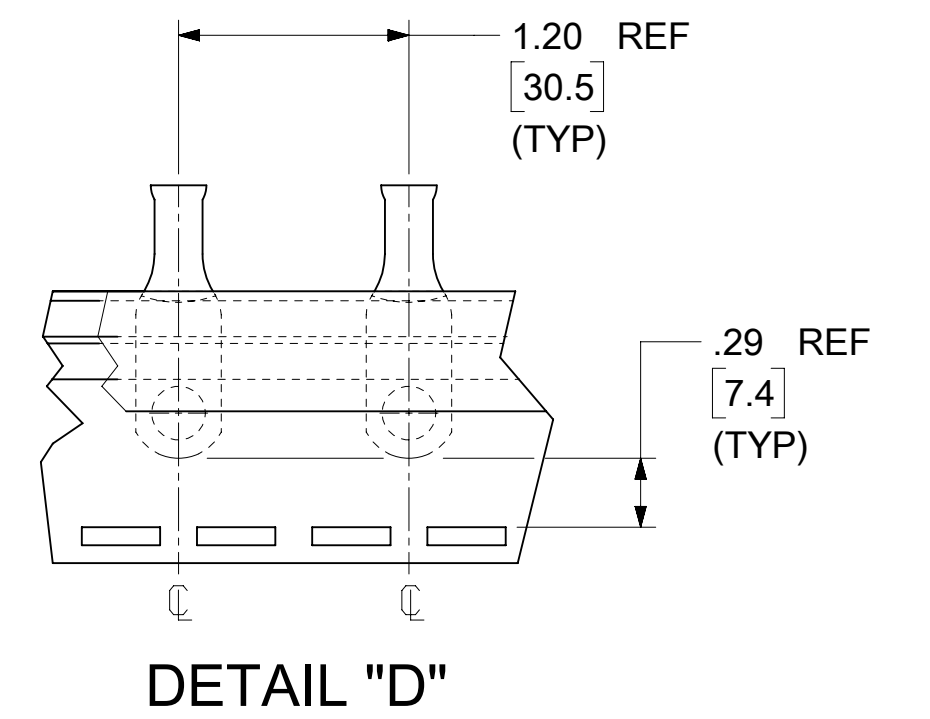
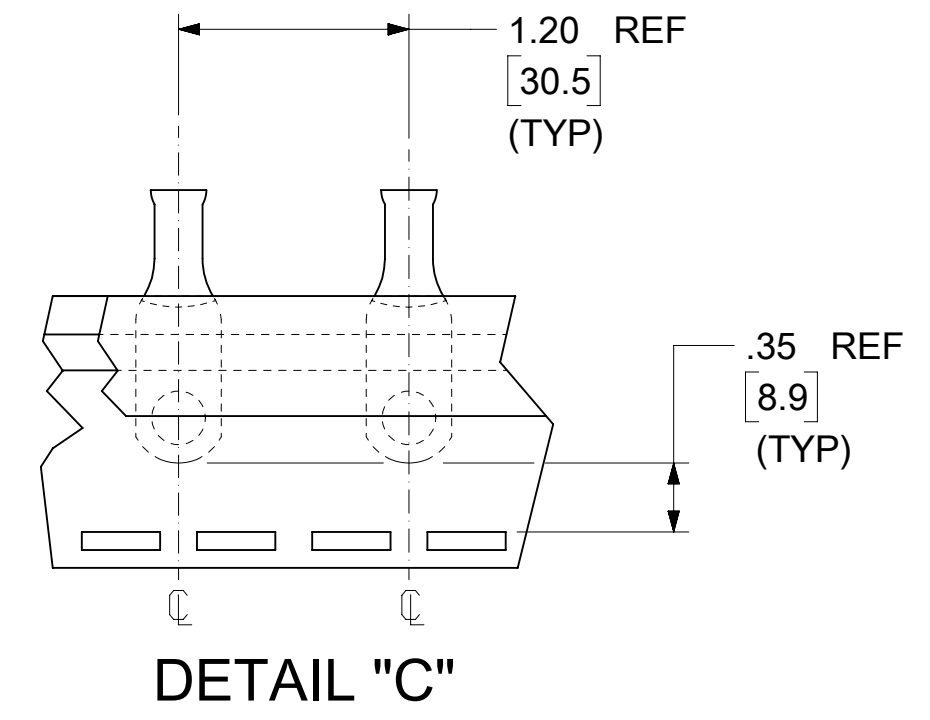
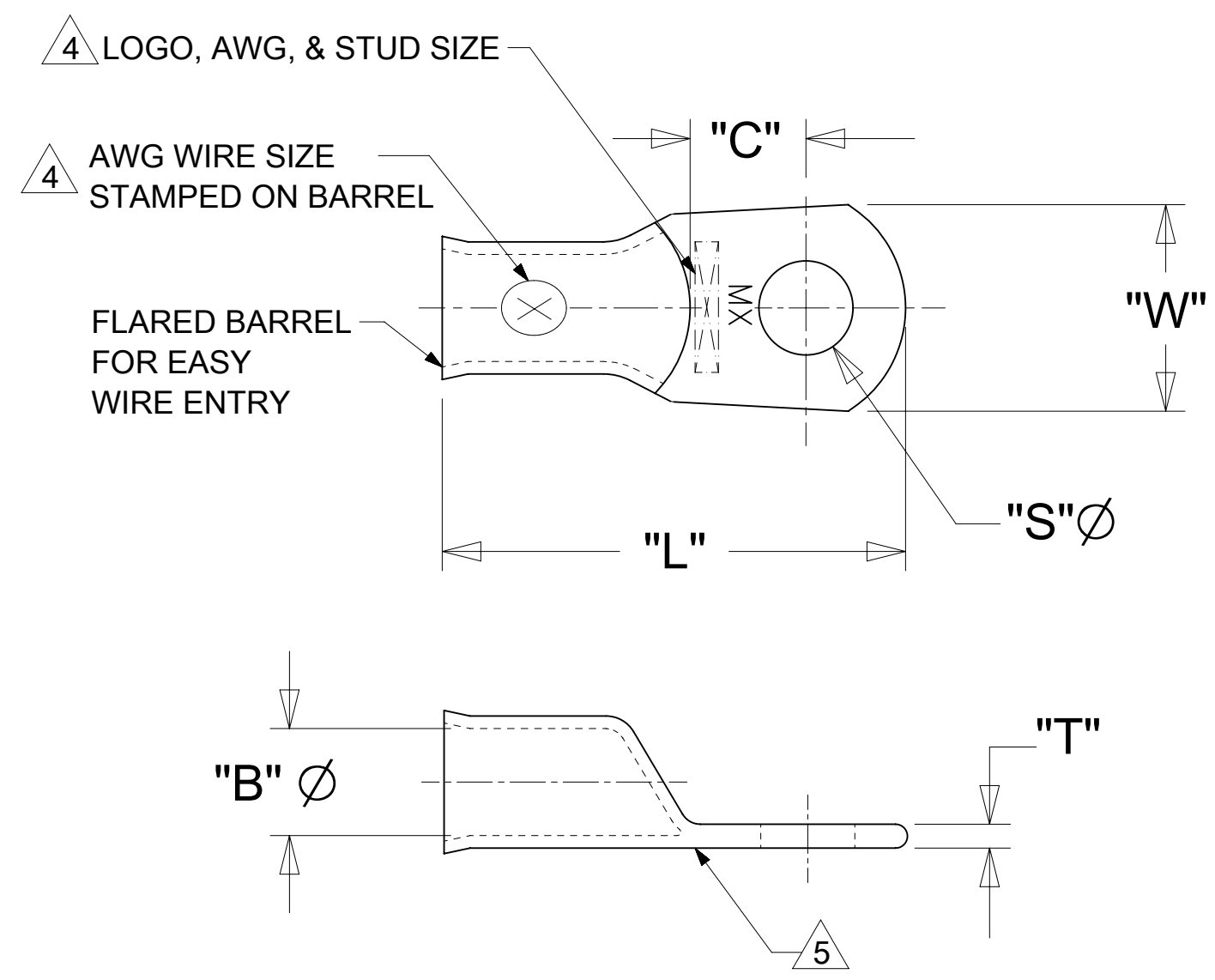

- NOTE(S):
- FOR INSPECTION SIGHT HOLE, PLEASE CONSULT WITH FACTORY.
 - OTHER STUD SIZES MAY BE AVAILABLE, PLEASE CONSULT WITH FACTORY.
 - MATERIAL: COPPER
PLATING: TIN
 - MARKINGS CAN BE AT EITHER LOCATION SHOWN.
 - IF TONGUE IS TO BE BENT AT ANY ANGLE, IT MUST BE BENT AROUND A RADIUS ONE-HALF THE TONGUE THICKNESS.
 - ALL PARTS ARE RoHS COMPLIANT.

THIS DRAWING CONTAINS INFORMATION THAT IS PROPRIETARY TO MOLEX ELECTRONIC TECHNOLOGIES, LLC AND SHOULD NOT BE USED WITHOUT WRITTEN PERMISSION											
DIMENSION UNITS		SCALE		CURRENT REV DESC: REMOVED INACTIVE PN'S							
IN/MM		NTS		<p>molex</p> <p>EYELET STYLE COPPER TERMINALS 4, 2, & 1 AWG LUGS</p> <p>PRODUCT CUSTOMER DRAWING</p> <p>DOCUMENT NUMBER: SD-19221-010 DOC TYPE: PSD DOC PART: 001 REVISION: D</p> <p>MATERIAL NUMBER: SEE CHART CUSTOMER: GENERAL MARKET SHEET NUMBER: 1 OF 1</p>							
GENERAL TOLERANCES (UNLESS SPECIFIED)											
	MM	INCH									
4 PLACES	±	±									
3 PLACES	±	±									
2 PLACES	±	±									
1 PLACE	±	±									
0 PLACES	±	±									
ANGULAR TOL ± °				EC NO: 739834				2023/02/17			
DRAFT WHERE APPLICABLE MUST REMAIN WITHIN DIMENSIONS				DRWN: DEANM1				2023/02/23			
THIRD ANGLE PROJECTION				CHK'D: JMACNEIL				2023/02/23			
DRAWING: C-SIZE				APPR: JMACNEIL				INITIAL REVISION:			
SERIES: 19221				DRWN: BE				2002/06/26			
				APPR: RD				2002/06/26			