

PFE Series

AC-DC Single Output Power Module



**Changing the Paradigm of Complex
Power Supply System**

PFE Series

PFHC (AC-DC Conversion) and DC-DC Conversion Integrated in One Package.

2-in-1 Design Concept

One module now contains the functions previously only obtainable by combining a front-end module with a high voltage input DC-DC converter. The product is made using a wide range input AC-DC front end function (harmonic current control and power factor correction) and DC-DC back-end (voltage conversion and isolation) in 1 package).

【Huge reduction in space】

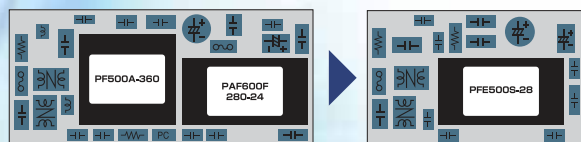

(old product)

(PFE Series)

Enhanced Surge Immunity Level

It is possible to clear 6kV surge voltage in normal and common mode (absorber is installed in the input filter).

Full Function (F type)

- By utilizing output current balancing function, parallel operation up to 6 units is possible.
- ON/OFF Control. ON/OFF control is possible even there is no ON/OFF in input circuit. ON/OFF control circuit is in between primary & secondary isolation.
- Inverter Operation Good signal
- Auxiliary Supply available

High Power Density:0.95/
High Efficiency:89%/
Input Voltage:85 ~ 265VAC

PFHC is provided, primary and secondary isolation for better safety and wide input range. High efficiency with up to 100°C base plate temperatures. (PFE500S-12, PFE500F-12: Up to 85°C)

Solution to Serve Different Kinds of Market Demands

PFE series features offer many reliable solutions. Thanks to its compact size and reduction in cost, power distribution is easier to construct than before. More over, high power density and N+1 redundant parallel operation increase the reliability. High base plate temperature and 6kV surge immunity level makes PFE series suitable to be used in harsh outdoor environment. After all, new functions are added to each models to give reliable solution to many market demands.

PFE Series



【Application Example】

PFE-F SERIES AC-DC Single Output Power Module



■ Features

- PFHC & DC-DC conversion integrated in one package
- Wide input voltage range: 85-265VAC
- High power factor: 0.95, meet PFHC standard (EN-61000-3-2)
- High efficiency: max. 86%
- Wide base plate temperatures: -40°C to +100°C
- Full function model
 - N+1 Redundant parallel operation
 - Current sharing (load current balancing)
 - IOG (Inverter Operation Good signal)
 - Auxiliary supply available
 - ON/OFF control
 - Power ON signal
- Built-in capacitor: ceramic capacitors only (high reliability)

■ Applications

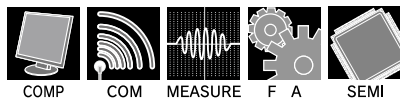

■ Product Line up

PFE-F.(AC85-265Vin)

Output Voltage	500W		1000W	
	Output Current	Model	Output Current	Model
12V	42A	PFE500F-12	60A	PFE1000F-12
28V	18A	PFE500F-28	36A	PFE1000F-28
48V	10.5A	PFE500F-48	21A	PFE1000F-48

■ Model naming method

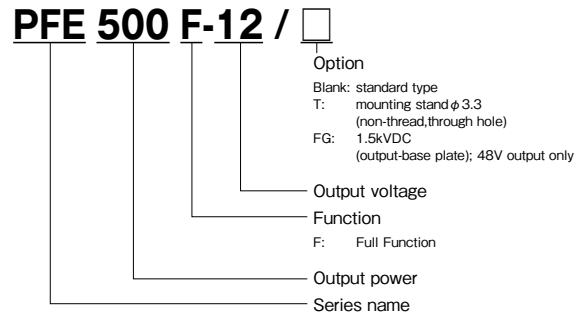

■ Conformity to RoHS Directive

This means that, in conformity with EU Directive 2002/95/EC, lead, cadmium, mercury, hexavalent chromium, and specific bromine-based flame retardants, PBB and PBDE, have not been used, except for exempted applications.

PFE500F Specifications

ITEMS/UNITS		MODEL	PFE500F-12	PFE500F-28	PFE500F-48
Input	Voltage Range	(*2) (*5) V	85 - 265 VAC		
	Frequency	(*2) Hz	47 - 63		
	Power Factor	(*1)(*5)	0.95		
	Efficiency (Typ)	(*1) %	81 / 83	84 / 86	
	Current	(*1) A	6.8 / 3.4	6.4 / 3.2	
	Inrush Current (Typ)	(*1)(*5) A	20 / 40 peak		
Output	Nominal Voltage	(*1) VDC	12	28	48
	Maximum Current	A	42	18	10.5
	Maximum Power	W	504		
	Voltage Setting Accuracy	%	+/-2		
	Maximum Line Regulation	mV	48	56	96
	Maximum Load Regulation	mV	48	56	96
	Maximum Ripple & Noise (*5)	mVp-p	120	280	480
	Voltage Adjustable Range	%	-20 / +20		
Function	Over Current Protection		105% - 140% (Automatic recovery method)		
	Over Voltage Protection (*8)		125% - 145% (Inverter shutdown method)		
	Remote Sensing (*6)		Possible		
	Remote ON/OFF Control (*6)		Possible		
	Parallel Operation (*6)		Possible		
	Series Operation (*6)		Possible		
Environment	Operating Temperature (*3)(*7)	°C	-40 - +85(Baseplate)	-40 - +100(Baseplate)	
	Storage Temperature	°C	-40 - +100		
	Operating Humidity	% RH	20 - 95 (No Dewdrop)		
	Storage Humidity	% RH	10 - 95 (No Dewdrop)		
	Vibration		At no operating, 10-55Hz (Sweep for 1min.) Amplitude 0.825mm constant (Maximum 49.0m/s ²) X,Y,Z 1 hour each		
	Shock		196.1m/s ²		
	Cooling (*4)		Conduction Cooled		
Standards	Safety Standards		Approved by UL60950-1, CSA C22.2 No.60950-1, EN60950-1		
Isolation	Withstand Voltage		Input-Baseplate : 2.5kVAC, Input-Output : 3.0kVAC for 1min. Output-Baseplate : 500VDC for 1min.		
	Isolation Resistance		Output-Baseplate 500VDC more than 100MΩ (25°C,70%RH)		
Mechanical	Weight (Typ)	g	300		
	Size (W x H x D)	mm	70 x 12.7 x 122 (Refer to Outline Drawing)		

- (*1) At 100VAC/200VAC and maximum output power. (Baseplate Temperature = +25°C.)
- (*2) For cases where conformance to various safety specs (UL, CSA, EN) are required, input voltage range will be 100 - 240VAC(50/60Hz).
- (*3) Ratings - refer to Derating Curve on the right.
- (*4) Heatsink has to be chosen according to Instruction manual.
- (*5) External components are needed for operation. (Refer to basic connection and instruction manual.)
- (*6) Refer to Instruction manual.
- (*7) Ambient Temperature min=-40°C
- (*8) OVP reset : Line off or Control off. (Refer to instruction manual.)

Derating Curve

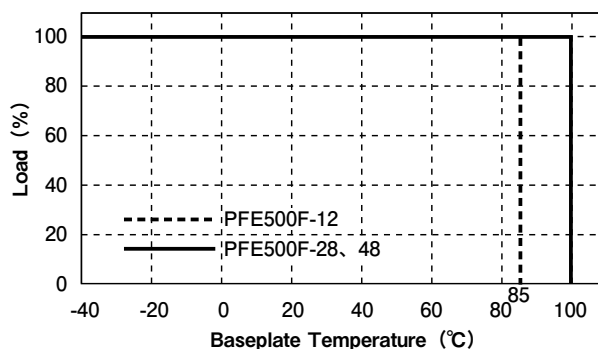

PFE500F Outline Drawing

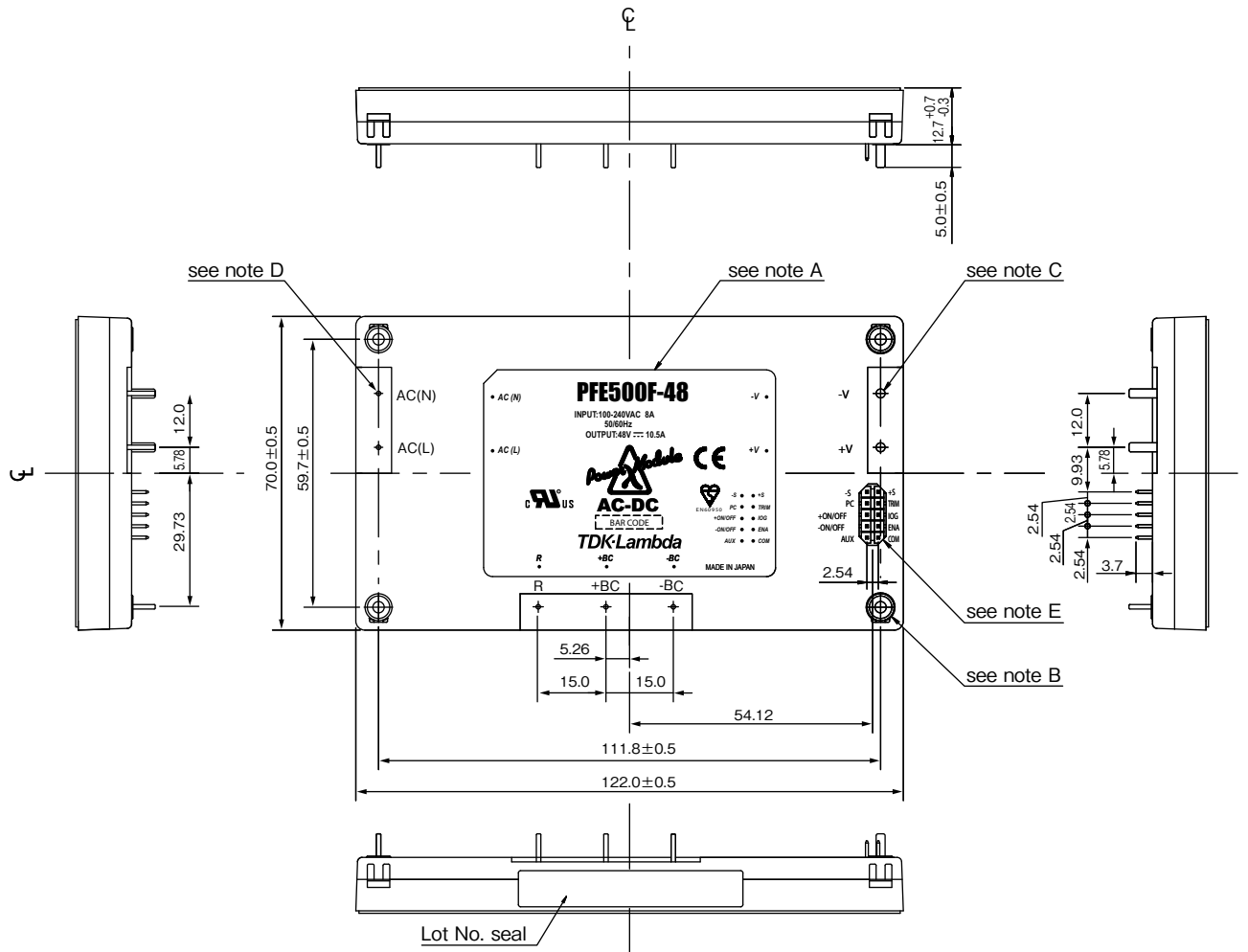

NOTES:

- A: Model name, input voltage range, Nominal output voltage, Maximum output current, country of manufacture and safety marking (C-UL-US, BSI & CE marking) are shown here in accordance with the specifications.
- B: M3 tapped holes 4 for customer chassis mounting (FG).
- C: Output terminal : 2-Φ2
- D: Input and Intermediate terminal : 5-Φ1
- E: Signal pin (+S, -S, TRIM, ENA, IOG, AUX, +ON/OFF, -ON/OFF, PC, COM) : 10-□0.64
- F: Unless otherwise specified dimensional tolerance : ±0.3

Basic Connection

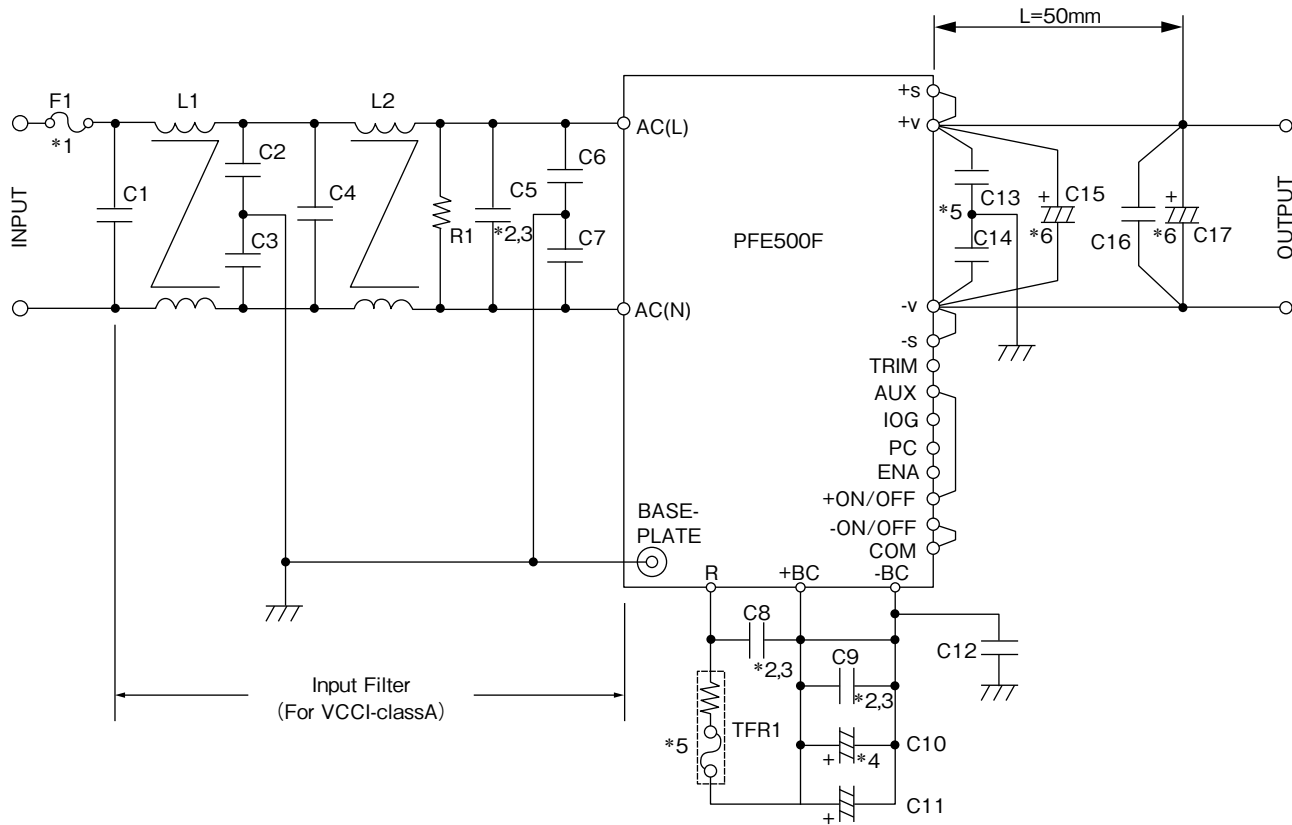

F1	AC250V 15A	C12	2200pF
R1	0.5W 470kΩ	C13	0.033uF
C1	AC250V 1uF (Film)	C14	0.033uF
C2	2200pF	C15	12V: 25V 1000uF (Elec.)
C3	2200pF		28V: 50V 470uF (Elec.)
C4	AC250V 1uF (Film)		48V: 100V 220uF (Elec.)
C5	AC250V 1uF (Film)	C16	100V 2.2uF (Ceramic)
C6	2200pF	C17	12V: 25V 1000uF (Elec.)
C7	2200pF		28V: 50V 470uF (Elec.)
C8	450V 1uF (Film)		48V: 100V 220uF (Elec.)
C9	450V 1uF (Film)	TFR1	10Ω 139°C (Res., Thermal fuse)
C10	450V 390uF (Elec.)	L1	6mH
C11	450V 390uF (Elec.)	L2	6mH

(*1) Use an external fuse of fast blow type for each unit.

(*2) The allowable ripple current of capacitor must be more than 3A(rms).

(*3) Put this capacitor near the terminal as close as possible.

(*4) The maximum capacitance that can be used is less than 1200uF(Rated capacitance).

Avoid the connection of capacitance which is more than above, else it will lead to module to damage.

(*5) The inrush current at AC throw in can be suppressed by the external Resistor (Built-in thermal fuse) connected between the R and +BC terminals.

(*6) If the ambient temperature is less than -20° C, use twice the recommended capacitor above.

(*7) Refer to instruction manual for further details.

Block Diagram

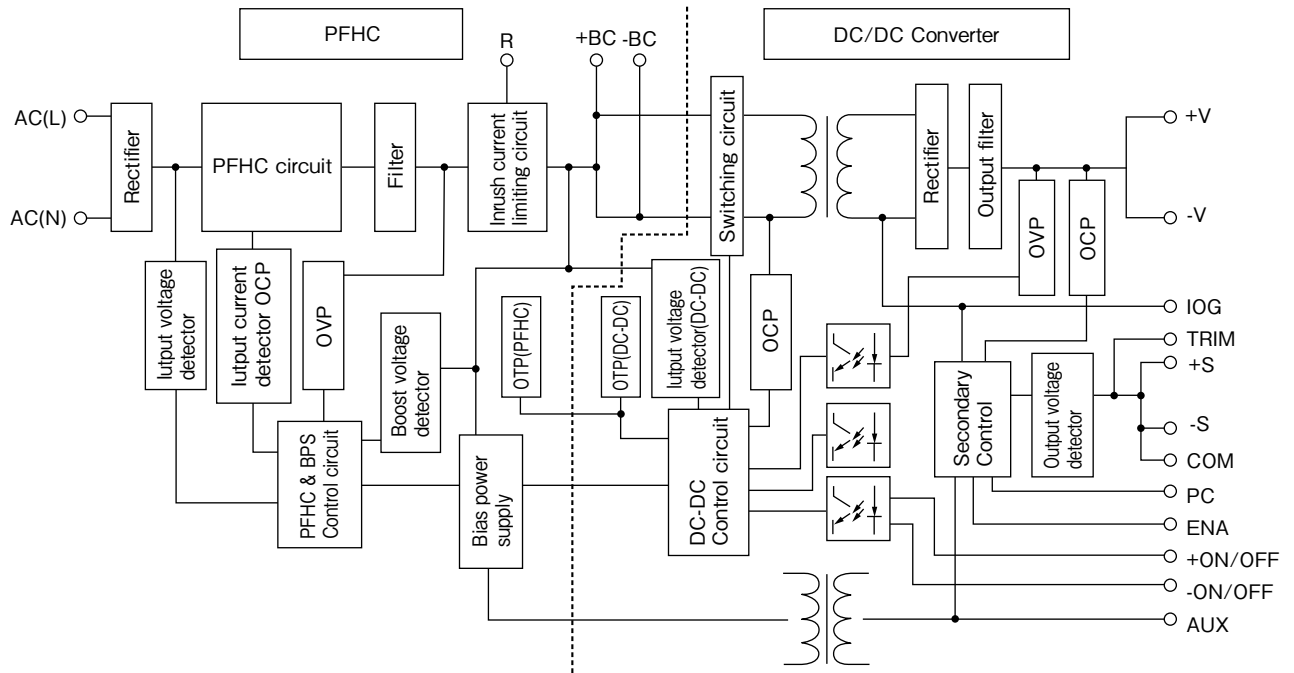

Switching Frequency

PFHC circuit (fixed) : 100kHz

DC/DC converter (fixed) : 230kHz (primary), 460kHz (secondary)

Sequence Time Chart

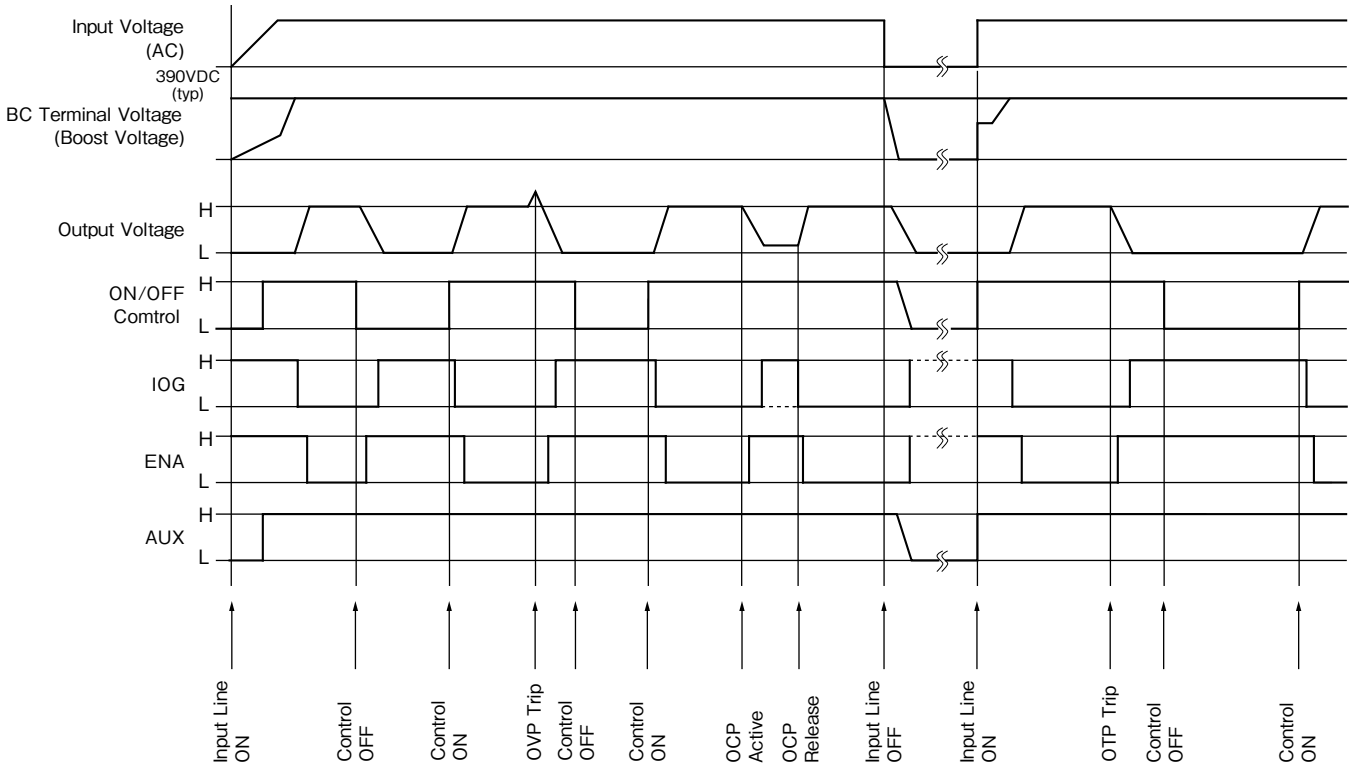

V* voltage level: Refer to Application Notes "13.Power ON Signal" section.

PFE1000F Specifications

ITEMS/UNITS		MODEL	PFE1000F-12	PFE1000F-28	PFE1000F-48
Input	Voltage Range	(*2)(*3) V	85 - 265 VAC		
	Frequency	(*2) Hz	47 - 63		
	Power Factor	(*1)(*3)	0.95		
	Efficiency (Typ)	(*1) %	80 / 82	84 / 86	
	Current	(*1) A	9.8 / 4.8	13.6 / 6.6	13.4 / 6.5
	Inrush Current (Typ)	(*1)(*3) A	20 / 40 peak		
Output	Nominal Voltage	(*1) VDC	12	28	48
	Maximum Current	A	60	36	21
	Maximum Power	W	720	1008	
	Voltage Setting Accuracy	%	+/-2		
	Maximum Line Regulation	mV	48	56	96
	Maximum Load Regulation	mV	48	56	96
	Maximum Ripple & Noise (*3)	mVp-p	120	280	480
	Voltage Adjustable Range	%	-20 / +20		
Function	Over Current Protection (*4)(*5)		105% - 140%		
	Over Voltage Protection (*5)		125% - 145% (Inverter shutdown method)		
	Remote Sensing (*6)		Possible		
	Remote ON/OFF Control (*6)		Possible		
	Parallel Operation (*6)		Possible		
	Series Operation (*6)		Possible		
Environment	Operating Temperature (*7)(*8)	°C	-40 - +100(Baseplate)		
	Storage Temperature	°C	-40 - +100		
	Operating Humidity	% RH	20 - 95 (No Dewdrop)		
	Storage Humidity	% RH	10 - 95 (No Dewdrop)		
	Vibration		At no operating, 10-55Hz (Sweep for 1min.) Amplitude 0.825mm constant (Maximum 49.0m/s ²) X,Y,Z 1 hour each		
	Shock		196.1m/s ²		
	Cooling	(*9)	Conduction Cooled		
Isolation	Withstand Voltage		Input-Baseplate : 2.5kVAC, Input-Output : 3.0kVAC for 1min. Output-Baseplate : 500VDC for 1min.		
	Isolation Resistance		Output to Baseplate 500VDC more than 100MΩ (25°C,70%RH)		
Standards	Safety Standards		Approved by UL60950-1, CSA60950-1, EN60950-1		
Mechanical	Weight (Typ)	g	500		
	Size (W x H x D)	mm	100 x 13.4 x 160 (Refer to Outline Drawing)		

- (*1) At 100VAC/200VAC and maximum output power. (Baseplate Temperature = +25°C.)
- (*2) For cases where conformance to various safety specs (UL, CSA, EN) are required, input voltage range will be 100 - 240VAC(50/60Hz).
- (*3) External components are needed for operation. (Refer to basic connection and instruction manual.)
- (*4) Constant current limiting. (The unit automatically shutdown when left in OCP condition, with the output voltageless than the LVP level. Refer to instruction manual.)
- (*5) Reset : Line off or Control off. (Refer to instruction manual.)
- (*6) Refer to Instruction manual.
- (*7) Ambient Temperature min=-40°C
- (*8) Ratings - refer to Derating Curve.
- (*9) Heatsink has to be chosen according to Instruction manual.

Derating Curve

PFE1000F-12

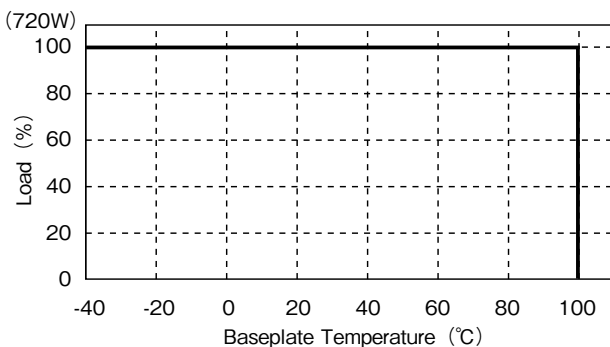

PFE1000F-28,48

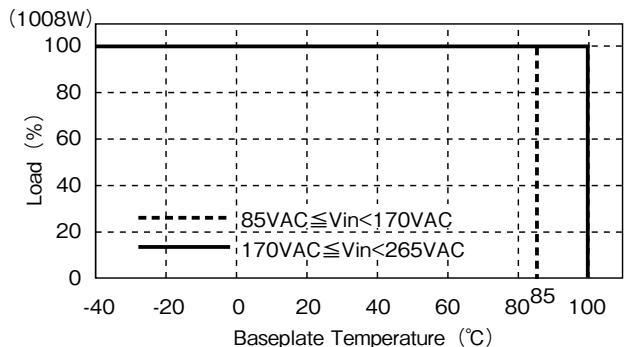

PFE1000F Outline Drawing

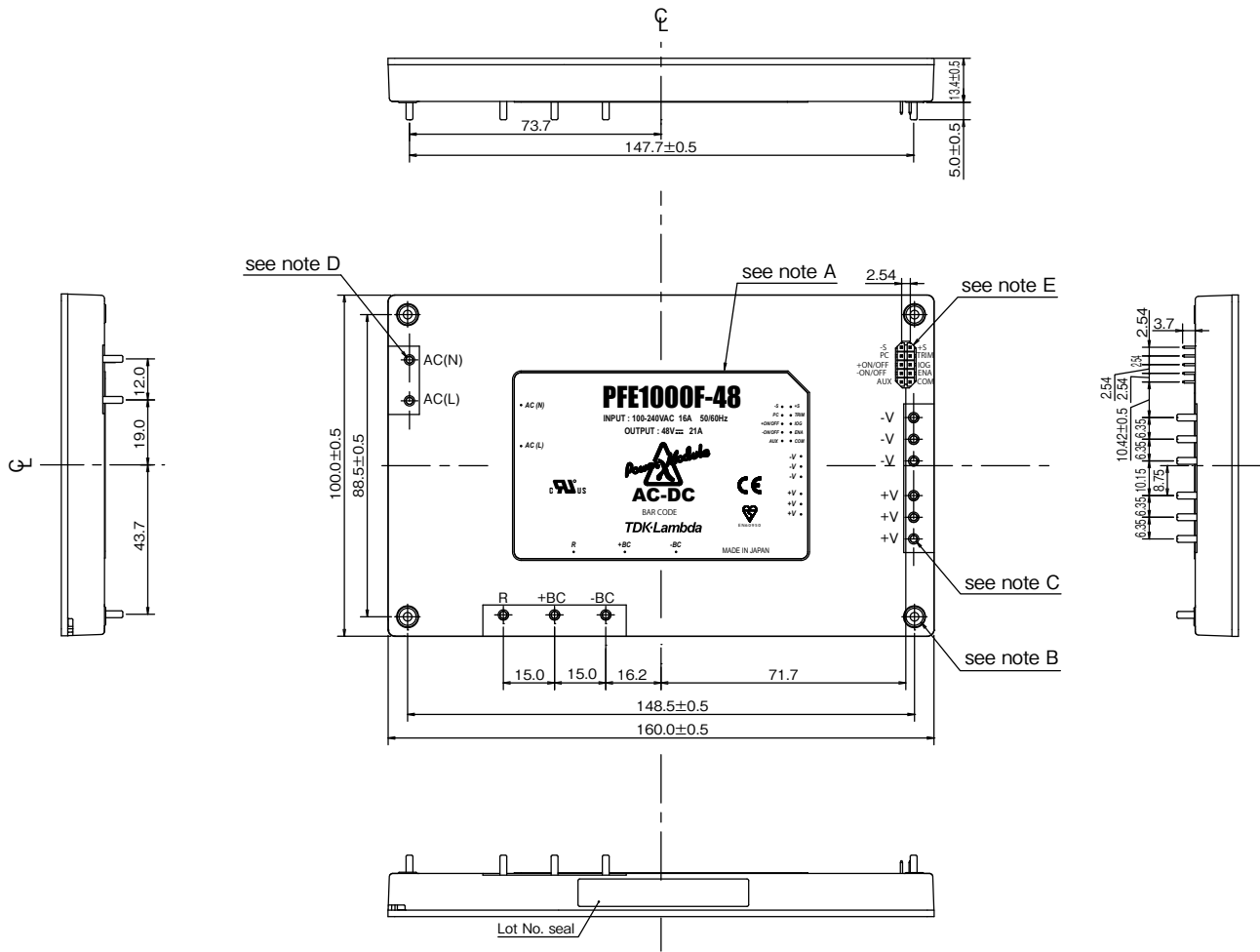

NOTES:

- A: Model name, input voltage range, Nominal output voltage, Maximum output current, country of manufacture and safety marking (C-UL-US, BSI & CE marking) are shown here in accordance with the specifications.
- B: M3 tapped holes 4 for customer chassis mounting (FG).
- C: Output terminal : 6-Φ2
- D: Input and Intermediate terminal : 5-Φ2
- E: Signal pin (+S, -S, TRIM, ENA, IOG, AUX, +ON/OFF, -ON/OFF, PC, COM) : 10-□0.64
- F: Unless otherwise specified dimensional tolerance : ±0.3

Basic Connection

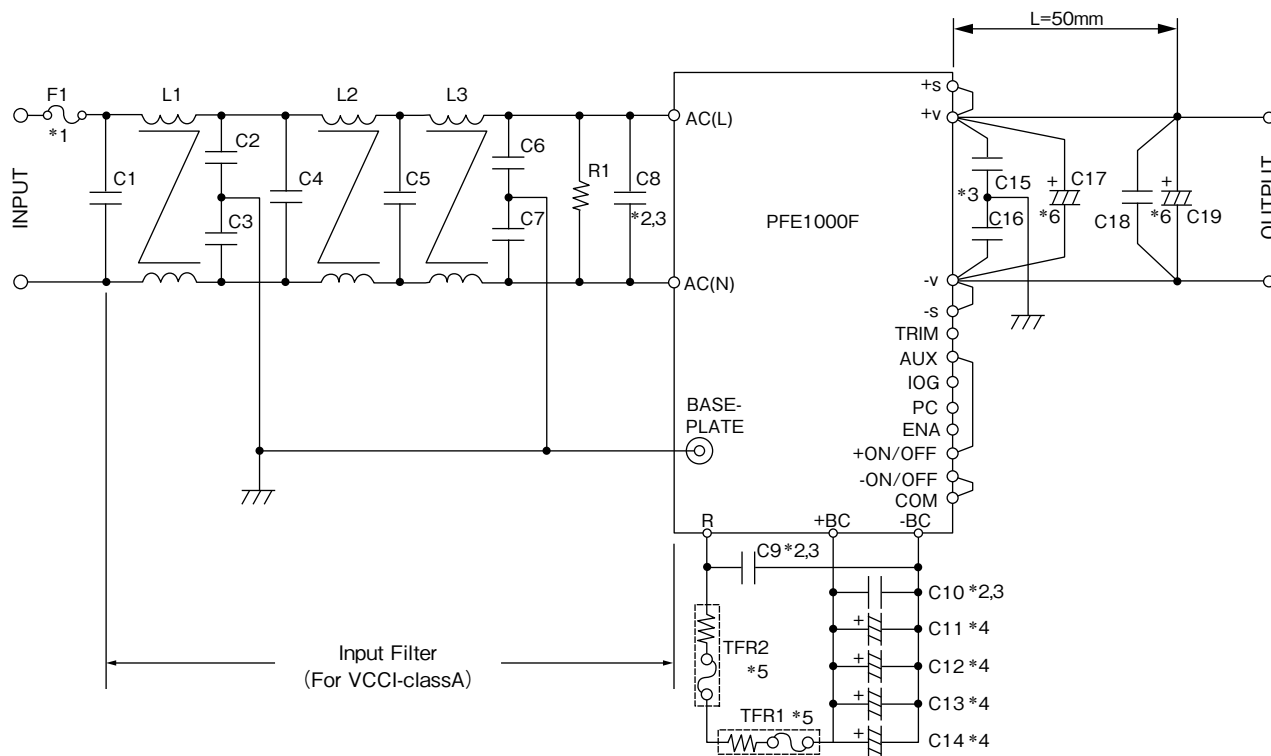

F1	F25AH250V	C15	0.033uF
C1	AC250V 1uF (Film)	C16	0.033uF
C2	470pF	C17	12V : 25V 1000uF (Elec.)
C3	470pF		28V : 50V 470uF (Elec.)
C4	AC250V 1uF (Film)		48V : 100V 220uF (Elec.)
C5	AC250V 1uF (Film)	C18	100V 2.2uF (Ceramic)
C6	4700pF	C19	12V : 25V 1000uF (Elec.)
C7	4700pF		28V : 50V 470uF (Elec.)
C8	AC250V 1uF (Film)		48V : 100V 220uF (Elec.)
C9	450V 1uF (Film)	R1	0.5W470kΩ
C10	450V 1uF (Film)	TFR1	5.1Ω139°C (Res., Thermal fuse)
C11	450V 390uF (Elec.)	TFR2	5.1Ω139°C (Res., Thermal fuse)
C12	450V 390uF (Elec.)	L1	2mH
C13	450V 390uF (Elec.)	L2	2mH
C14	450V 390uF (Elec.)	L3	2mH

(*1) Use an external fuse of fast blow type for each unit.

(*2) The allowable ripple current of capacitor must be more than 3A(rms).

(*3) Put this capacitor near the terminal as close as possible.

(*4) The maximum capacitance that can be used is less than 2300uF(Rated capacitance).

Avoid the connection of capacitance which is more than above of else it will lead to module damage.

(*5) The inrush current at AC throw in can be suppressed by the external Resistor (Built-in thermal fuse) connected between the R and +BC terminals.

(*6) If the ambient temperature is less than -20°C, use twice the recommended capacitor above.

(*7) Refer to instruction manual for further details.

Block Diagram

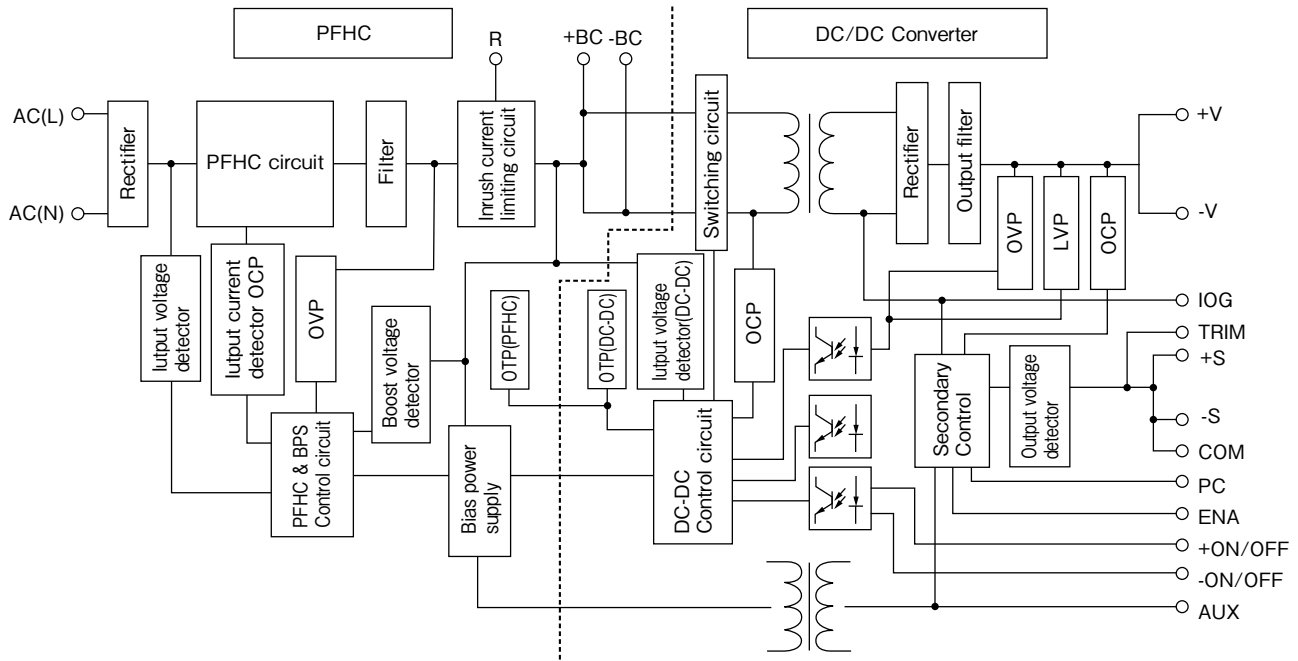

Switching Frequency

PFHC circuit (fixed) : 100kHz

DC/DC converter (fixed) : 230kHz (primary), 460kHz (secondary)

Sequence Time Chart

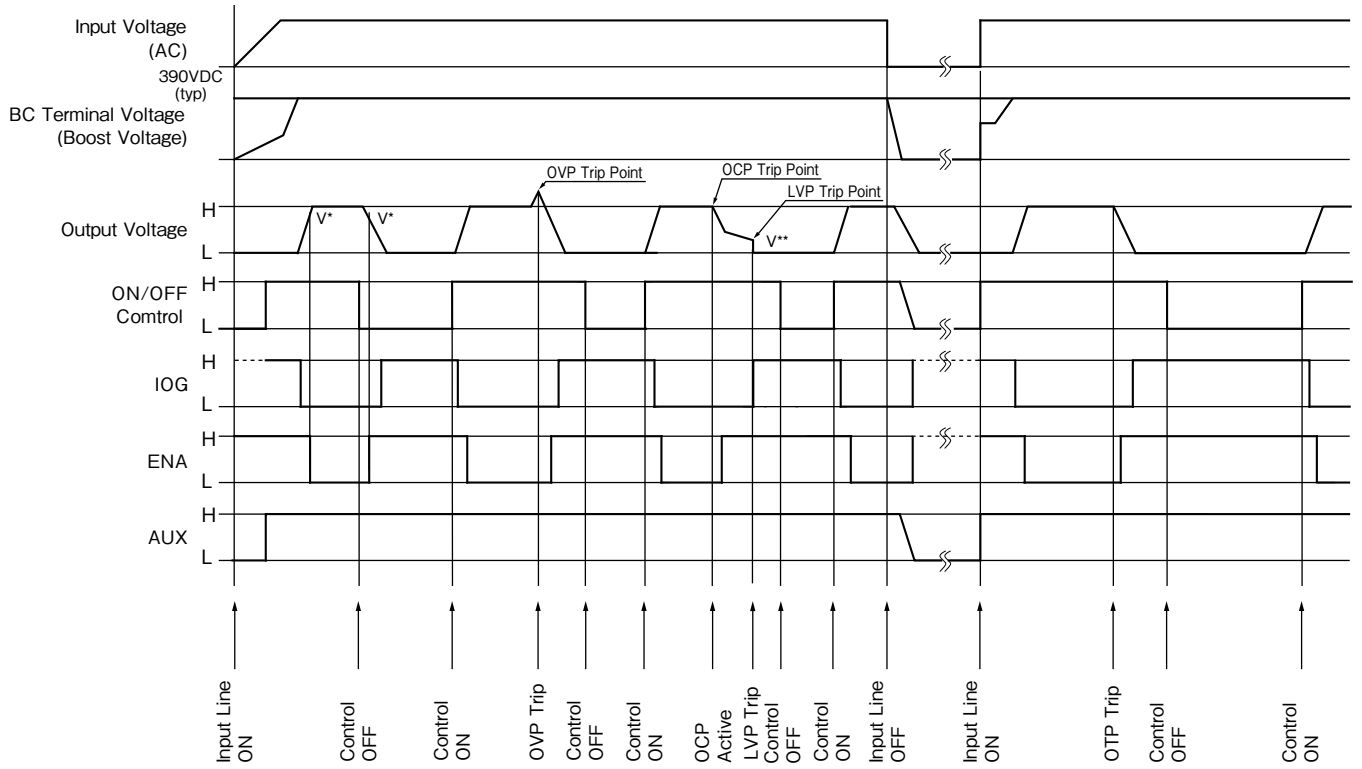

V* voltage level: Refer to Application Notes "13.Power ON Signal" section.
 V** voltage level: Refer to Application Notes "6.Over Current Protection" section.

PFE500F, 1000F SERIES Instruction Manual

BEFORE USING THE POWER SUPPLY UNIT

Be sure to read this instruction manual thoroughly before using this product. Pay attention to all cautions and warnings before using this product. Incorrect usage could lead to an electrical shock, damage to the unit or a fire hazard

DANGER

- Never use this product in locations where flammable gas or ignitable substances are present.

WARNING

- Do not make unauthorized changes to power supply unit, otherwise you might have electric shock and void your warranty.
- Do not touch this unit and the internal components in operation or shortly after shut down. They might have high voltage or high temperature and as the unit dissipates its heat so the surface of the unit is hot. You might receive electric shock or burn.
- When the unit is operating, keep your hands and face away from it; you might be injured by an accident.
- Do not use unit under unusual condition such as emission of smoke or abnormal smell and sound etc. It might cause fire and electric shock. In such case, please contact us; do not repair by yourself, as it is dangerous for the user.
- Do not drop or insert anything into unit. It might cause failure and fire.
- Do not operate these units under condensation condition. It might cause fire and electric shock.

CAUTION

- As a component part, compliance with the standard will be based upon installation in the final application. This product must be installed in a restricted access location, accessible to authorized competent personnel only. These AC to DC converters have reinforced insulation between the input and the output. The outputs of these products are energy hazards. All models with an output greater than 48V model are considered to be non-SELV. As such, the instructions for use must refer to these energy hazardous outputs and Non-SELV outputs in that the outputs must not be accessible to the operator. The installer must also provide protection against inadvertent contact by a service engineer.
- The equipment has been evaluated for use in a Pollution Degree 2 environment.
- This power supply is primarily designed and manufactured to be used and enclosed in other equipment.
- Confirm connections to input/output terminals and signal terminals are correct as indicated in the instruction manual.
- Attach a fast acting external fuse to each module to ensure safety operation and compliance to each safety standard approval. The recommended input fuse rating within the instructions manual. The breaking capacity and voltage rating of this fuse might be subject to the end use application.

- Input voltage, Output current, Output power, ambient temperature and ambient humidity should be used within specifications, otherwise the unit will be damaged.
- For application equipment, which requires very high reliability (Nuclear related equipment, traffic control equipment, medical equipment, etc.), please provide fail safety function in the equipment.
- Do not use the product in environment with strong electromagnetic field, corrosive gas and conductive substance.
- Do not operate and store this unit at an environment where condensation occurs. In such case, waterproof treatment is necessary
- Never operate the unit under over current or shorted conditions for 30 seconds or more and out of Input Voltage Range as specification. Insulation failure, smoking, burning or other damage might occur to the unit.
- The output voltage of this power supply unit is considered to be a hazardous energy level (The voltage is 2V or more and the electric power is 240VA or more). Prevention from direct contact with output terminal is highly necessary. While installing or servicing this power supply unit, avoid dropping tools by mistake or direct contact with output terminal. This might cause an electrical shock. While repairing this power supply unit, the AC input power must be switched off and the input and output voltage should be level.
- To maintain the SELV output for outputs less than 28VDC, under fault conditions, the output must be connected to earth in the final application.
- The application circuits and their parameter are for reference only. Be sure to verify effectiveness of application circuits and their parameters before finalizing circuit design.
- Do not inject abnormal voltage to output terminal and signal terminal from the outside. The injection of reverse voltage or over voltage exceeding nominal output voltage to output terminals might cause damage to internal components.
- This information in this document is subject to change without prior notice. For actual design-in, please refer to the latest publications of data sheet, etc., for the most up-to date specifications of the unit.
- Design the board of an application circuit implementing this product in consideration of components layout, pattern layout and pattern width.
- No part of this document might be copied or reproduced in any form without prior written consent of TDK-Lambda.

Note : CE MARKING

CE Marking when applied to a product covered by this handbook indicates compliance with the low voltage directive (2006/95/EC) in that it complies with EN60950-1.

1. Terminal Explanation

■ PFE500F Series

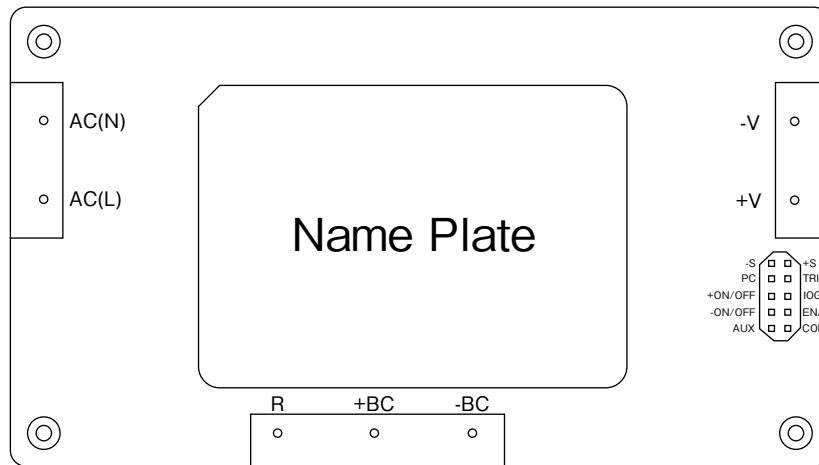

[Input side terminals]

AC(L) : Input terminal live line
 AC(N) : Input terminal neutral line

+BC : +Boost voltage terminal
 -BC : -Boost voltage terminal
 R : External inrush current limiting resistor terminal

[Output side terminals]

+V : +Output terminal
 -V : -Output terminal
 +S : +Remote sensing terminal
 -S : -Remote sensing terminal
 PC : Output current balance terminal
 TRIM : Output voltage trimming terminal
 IOG : Inverter operation good terminal
 ENA : Power on signal terminal
 +ON/OFF : +ON/OFF control terminal
 -ON/OFF : -ON/OFF control terminal
 AUX : Auxiliary power supply terminal for external circuits
 COM : Common ground terminal

- Baseplate can be connected to FG through M3 mounting tapped holes.
- Consider contact resistance when connecting AC (L), AC (N), R, +BC, -BC, +V, -V.
- Note that +BC and -BC terminals is a primary voltage with high voltage (390VDC). Do not connect load to these terminals. It might result in power module damage.

■PFE1000F Series

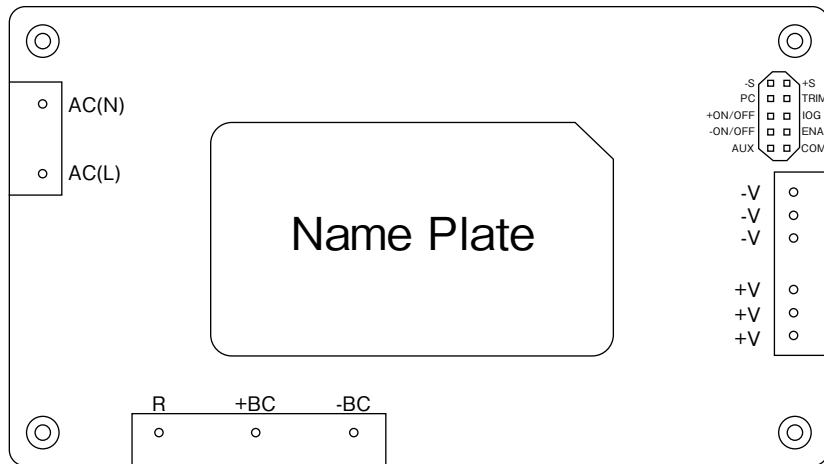

[Input side terminals]

AC(L) : Input terminal live line
 AC(N) : Input terminal neutral line

+BC : +Boost voltage terminal
 -BC : -Boost voltage terminal
 R : External inrush current limiting terminal

[Output side terminals]

+V : +Output terminal
 -V : -Output terminal

+S : +Remote sensing terminal
 -S : -Remote sensing terminal
 PC : Output current balance terminal
 TRIM : Output voltage trimming terminal
 IOG : Inverter operation good terminal
 ENA : Power on signal terminal
 +ON/OFF : +ON/OFF control terminal
 -ON/OFF : -ON/OFF control terminal
 AUX : Auxiliary power supply terminal for external circuits
 COM : Common ground terminal

- Baseplate can be connected to FG through M3 mounting tapped holes.
- Consider contact resistance when connecting AC (L), AC (N), R, +BC, -BC, +V, -V.
- Note that +BC and -BC terminals is a primary voltage with high voltage (390VDC). Do not connect load to these terminals. It might result in power module damage.

2. Explanations on Specifications

1 Input Voltage Range

Input voltage range is indicated below. Take care not to apply input voltage which is above this specified range or under this specified range for more than 30 seconds. Nor

● Basic Connection

should a DC input voltage be applied as this would result into power module damage.

Input Voltage Range : Single Phase 85 to 265VAC
Line Frequency Range : 47 to 63Hz

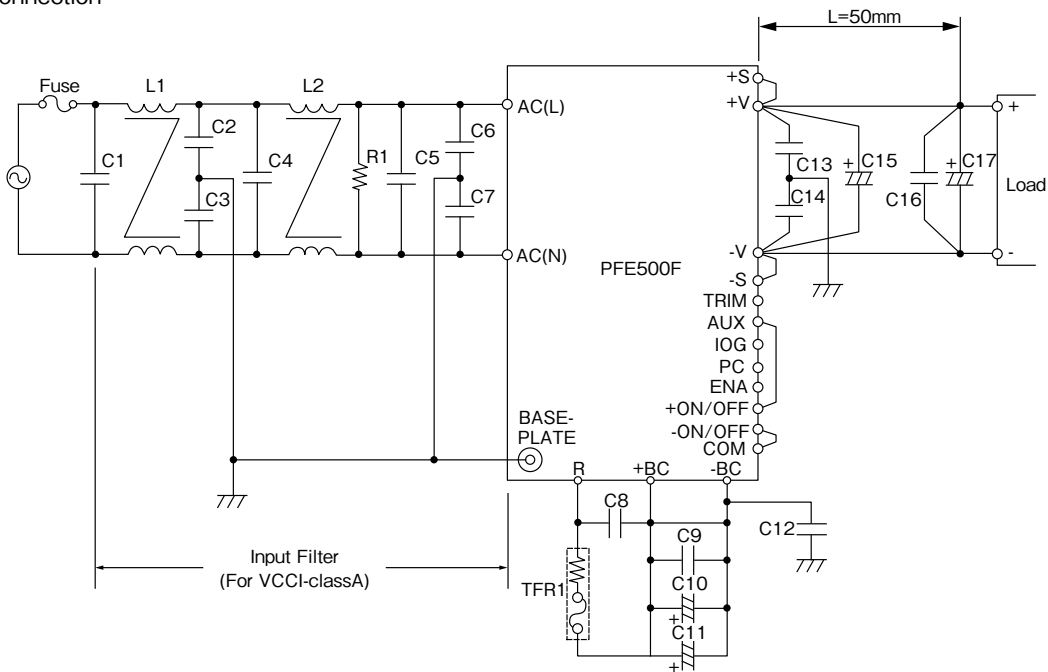

Fig. 1-1-(1) Basic Connection for PFE500F Series

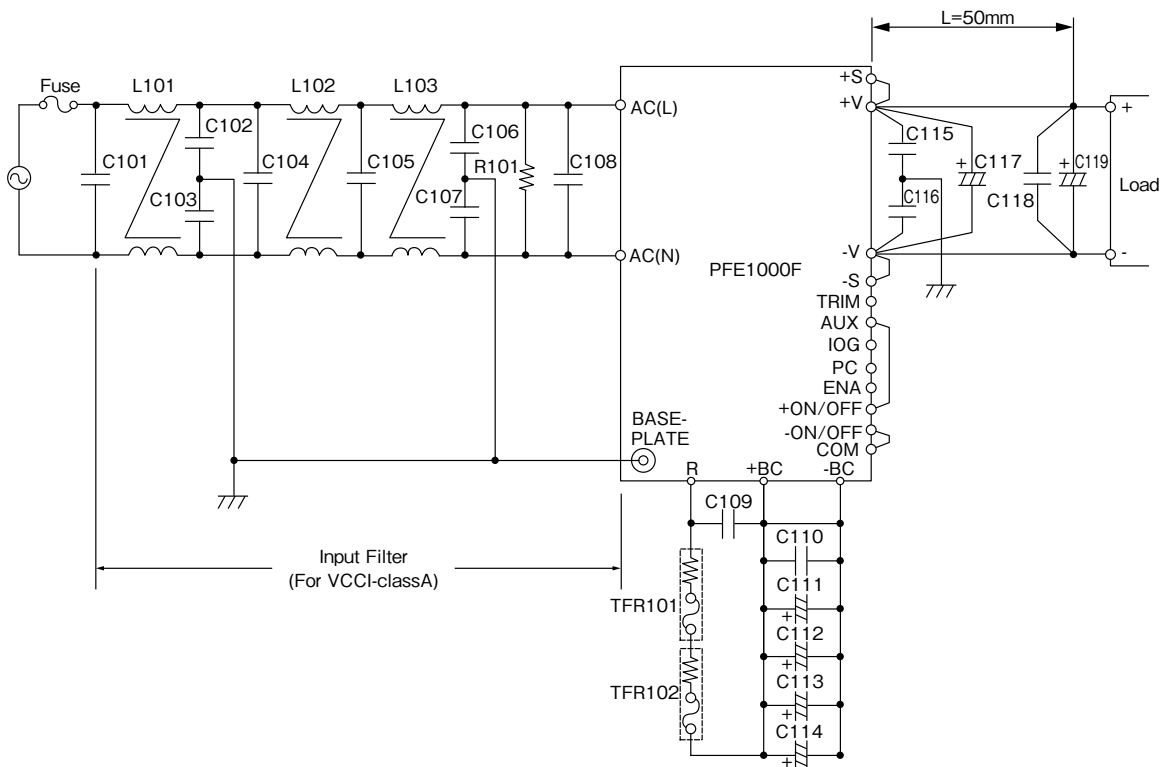

Fig. 1-1-(2) Basic Connection for PFE1000F Series

Note) To meet the surge immunity, evaluate the addition of the surge protection components.
Refer to separate document "PFE500F Series IEC Data" and "PFE1000F Series IEC Data".

F1 : External Input Fuse

This power module has no internal fuse. Use external fuse to acquire each Safety Standard and to further improve safety. Further, Fast-Blow type fuse must be used per one module. Also, in-rush surge current flows during line throw-in. Be sure to check I²t capability of external switch and fuse.

Recommended External Fuse
 PFE500F : F15AH, 250V
 PFE1000F : F25AH, 250V

Note) Select fuse based on rated voltage, rated current and breaking capacity.

(1) Voltage Ratings

100VAC line : AC125V
 200VAC line : AC250V

(2) Current Ratings

Rated current is selected by the maximum input current based on operating conditions and can be calculated by the following formula.

$$I_{in}(\max) = \frac{P_{out}}{V_{in} \times \text{Eff} \times \text{PF}} \text{ (Arms)} \quad \text{(Formula 1-1)}$$

I_{in} (max) : Maximum Input Current

P_{out} : Maximum Output Power

V_{in} : Minimum Input Voltage

Eff : Efficiency

PF : Power Factor

(3) Breaking Capacity

The breaking capacity may be subject to the end use application. Please select a suitably rated breaking capacity fuse for end use application.

For Efficiency and Power Factor values, refer to separate document "PFE500F Series Evaluation Data" and "PFE1000F Series Evaluation Data" .

C1, C4, C5 : 1uF (Film Capacitor)

C101, C104, C105, C108 : 1uF (Film Capacitor)

Ripple current flows through this capacitor. When selecting capacitor, be sure to check the allowable maximum ripple current rating of this capacitor. Verify the actual ripple current flowing through this capacitor by doing actual measurement.

Recommended Voltage Rating : 250VAC

Note) Connect C5, C108 as near as possible towards the input terminals of this power module.

Audible noise may occur depending on type of film capacitor.

L1, L2 : 6mH

L101, L102, L103 : 2mH

Add common mode choke coil to conform to EMI/EMS standard. When using multiple modules, connect coil to each module.

Note) Depending on the input filter used, noise might increase or power module might malfunction due to filter resonance.

C2, C3, C6, C7, C12: 2,200pF (Ceramic Capacitor)

C102, C103 : 470pF (Ceramic Capacitor)

C106, C107 : 4,700pF (Ceramic Capacitor)

Connect ceramic capacitor to conform to EMI/EMS standard. Be sure to note the leakage current of your equipment when connecting this capacitor.

High withstand voltage are applied across this capacitor depending on the application. Select capacitors with high withstand voltage rating.

R1, R101 : 470kohm

Connect bleeder resistor across AC(L) and AC(N) terminals.

C8, C9 : 1uF (Film Capacitor)

C109, C110 : 1uF (Film Capacitor)

Ripple current flows through this capacitor. When selecting capacitor, be sure to check the allowable maximum ripple current rating of this capacitor. Verify the actual ripple current flowing through this capacitor by doing actual measurement.

Recommended Voltage Rating : 450VDC

Note) Select Capacitor with more than 3A (rms) rating. Connect C8, C9, C109, C110 as near as possible towards the terminals of this power module.

C10, C11: 390uF (Electrolytic Capacitor)

C111, C112, C113, C114 : 390uF (Electrolytic Capacitor)

Refer to "Selection Method of External Bulk Capacitor for Boost Voltage" .

Allowable External Capacitance at nominal capacitor value is shown below.

Recommended Voltage Rating : 450VDC

Recommended Total Capacitor :

390uF to 1,200uF (PFE500F Series)

780uF to 2,300uF (PFE1000F Series)

Note)1. Do not connect capacitors with more than the above capacitance value as this might result in power module damage.

2. When using module between 390uF - 600uF for PFE500F Series, 780uF - 1,200uF for PFE1000F Series total capacitor value, it is necessary to reduce output power as shown in Fig1-3.

3. When using module below -20 deg C ambient temperature, AC ripple of boost voltage, output ripple voltage and start up characteristics might be affected by ESR characteristics of the bulk capacitors.

Therefore, be sure to verify characteristics by actual evaluation.

C13, C14, C115, C116 : 0.033uF

Connect ceramic or film capacitor to conform to EMI/EMS standard and to reduce output spike noise voltage.

Note) High Voltage is applied across this capacitor during withstand voltage test depending on the application.

Connect C13, C14, C115, C116 as near as possible towards the terminals of this power module.

C15, C117 : Refer to Table 1-1

To reduce output ripple voltage and to stabilize operation, connect electrolytic capacitors across +V and -V terminals.

Note) Connect C15, C117 as near as possible to the +V and -V terminals of this power module.

Vout	C15 , C117
12V	25V 1,000uF
28V	50V 470uF
48V	100V 220uF

Table 1-1 C15, C117: Recommended external capacitance

C16, C118 : 2.2uF (Ceramic Capacitor)

Connect ceramic capacitor within 50mm from the output terminals +V and -V of the power module to reduce output spike noise voltage.

Also, note that output spike noise voltage might vary depending on the wiring pattern of the printed circuit board.

C17, C119 : Refer to Table 1-2

Connect C17, C119 within 50mm from the output terminals +V and -V of the power module to stabilize operation and to reduce output ripple noise voltage.

Note that the output ripple and line turn off characteristics of the power module might be affected by the ESR and ESL of the electrolytic capacitor.

Also, note that output ripple voltage might vary depending on the wiring pattern of the printed circuit board.

Fluctuation in output voltage due to sudden load change or sudden input voltage change can be reduced by increasing external output capacitor value.

Vout	C17 , C119
12V	25V 1,000uF
28V	50V 470uF
48V	100V 220uF

Table 1-2 C17, C119: Recommended external capacitance

Note) 1. Use low-impedance electrolytic capacitors with excellent temperature characteristics.

(Nippon Chemi-con LXY Series or equivalent)
(Nichicon PM Series or equivalent)

- For module operation at ambient temperature -20 deg C or less, output ripple voltage might be affected by ESR characteristics of the electrolytic capacitors. Increase the capacitor values shown in Table 1-1 and 1-2 according to the table below.

Vout	C15 , C17 , C117 , C119
12V	25V 1,000uF x 2 parallel
28V	50V 470uF x 2 parallel
48V	100V 220uF x 2 parallel

Table 1-3 C15, C17, C117, C119 : Recommended external capacitance (Ambient Temperature < -20 deg C)

- Take note of the allowable maximum ripple current of the electrolytic capacitor used. Especially, for sudden load current changes, verify actual ripple current and make sure that allowable maximum ripple current is not exceeded.

● Selection Method of External Bulk Capacitor for Boost Voltage

Boost voltage bulk capacitor is selected by ripple voltage, ripple current and output hold-up time.

Select capacitor value such that boost voltage ripple voltage does not exceed 15Vp-p.

Note) When ambient temperature is -20 deg C or less, ripple voltage of the boost voltage might increase due to ESR characteristics. Therefore, verify above characteristics by actual evaluation.

For output hold-up time, refer to separate document "PFE500F Series Evaluation Data" or "PFE1000F Series Evaluation Data" and use appropriate capacitor up to 1,200uF maximum for PFE500F Series, 2,300uF maximum for PFE1000F Series. (It is recommended that verification should be done through actual evaluation).

For allowable ripple current value, refer to Fig. 1-2 and select a capacitor with higher ripple current rating.

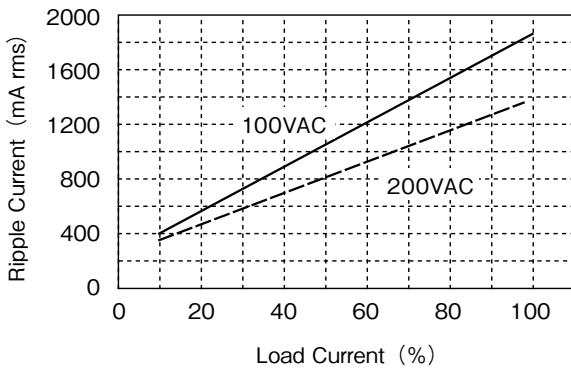

Fig. 1-2-(1) Ripple current value for PFE500F Series (A value per one of Fig. 1-1-(1) connection)

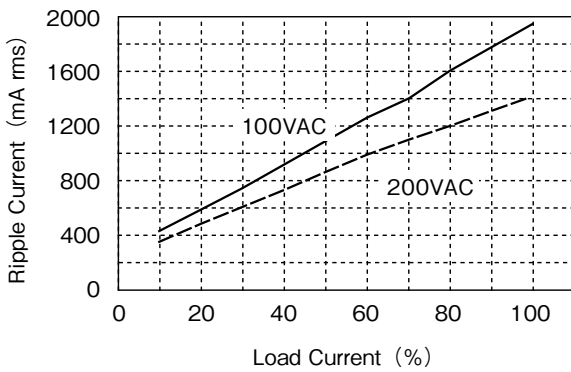

Fig. 1-2-(2) Ripple current value for PFE1000F Series (A value per one of Fig. 1-1-(2) connection)

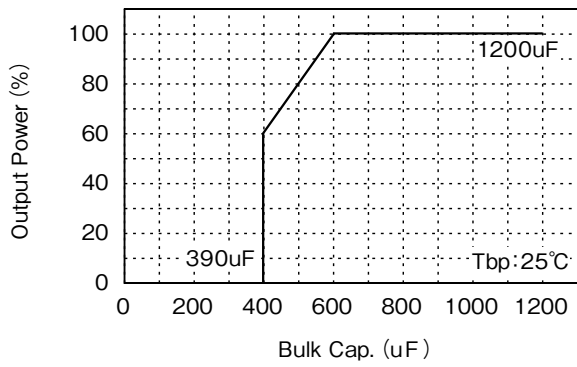

Fig. 1-3-(1) Output Power v.s. Boost Voltage Bulk Capacitance For PFE500F Series

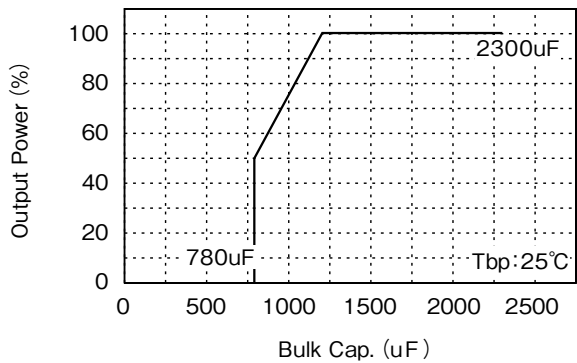

Fig. 1-3-(2) Output Power v.s. Boost Voltage Bulk Capacitance For PFE1000F Series

The recommended boost voltage bulk capacitor value range is 390uF-1,200uF for PFE500F Series, 780uF-2,300uF for PFE1000F Series.

When using with reduced the bulk capacitor value, it is necessary to reduce output power as shown in Fig1-3.

Note that reducing the bulk capacitance affects output hold-up time, dynamic line response and dynamic load response characteristics.

It is recommended that verification should be done through actual evaluation.

TFR1 : 10 to 100 ohm

TFR101, TFR102 : 10 to 50 ohm (Total value)

By connecting resistor across R and +BC terminals as shown in Fig. 1-1, in-rush current during line throw-in can be suppressed. Failures due to in-rush current such as melting of external fuse, welding of relay or switch connecting joints or shutdown of No-Fuse Breakers (NFB) might occur. Therefore, select TFR1, TFR101, TFR102 in consideration of the surge current capability of the external components. (TFR1, TFR101, TFR102 are recommended to use the Thermal Fuse Resistor.)

Note) 1. Do not connect resistors that is out of range from the values shown above as this might result in power module damage.

2. Note that this module will not operate without this external resistor.

● Selection Method of External Resistor

- (1) Calculating Resistance Value for External Resistor
Resistance can be calculated by the formula below.

$$R = \frac{V_{in}}{I_{rush}} \Omega \quad (\text{Formula 1-2})$$

R : Resistance Value for External resistor

V_{in} : Input Voltage converted to DC value
= Input Voltage (rms) × √2

I_{rush} : Input surge current value

- (2) Required Surge Current Rating

Sufficient surge current withstand capability is required for external resistor.

Required Surge Current Rating can be selected by I²t. (Current squared multiplied by time)

$$I^2t = \frac{C_o \times V_{in}^2}{2 \times R} (A^2s) \quad (\text{Formula 1-3})$$

I²t : Current-squared multiplied by time

C_o : Boost Voltage Bulk Capacitance

V_{in} : Input Voltage converted to DC value
= Input Voltage (rms) × √2

R : Resistance Value for External Resistor

2 Output Voltage Adjustment Range (TRIM terminal)

Output voltage can be adjusted within the range below by connecting fixed and variable resistors or applying external

voltage.

However, take care not to exceed the output voltage range shown below because OVP function will activate.

In the PFE1000F Series, be careful not to drop from the following range, because a Low Voltage Protection (LVP) function will be activate.

Output Voltage Adjustment Range :
+/-20% of the typical voltage rating

When increasing or decreasing output voltage, it must not exceed maximum output current and power.

Even if the output voltage is adjusted using external circuit shown in Fig. 2-1, remote sensing can be done. For details on Remote Sensing function, refer to "9. Remote Sensing".

Output Voltage Adjustment using Fixed and Variable Resistors

External resistor (R1) and variable resistor (VR) values, as well as, circuit connection is shown below.

For this case, remote programming of the output voltage can be done through the remote programming resistor VR.

Be sure to connect the remote programming resistor between +S and +V terminals

	12V	28V	48V
R1	18k	18k	18k
VR	10k	20k	50k

unit : [ohm]

External Resistor : Tolerance +/-5% or less

Variable Resistor : Total Tolerance +/-20% or less

Remain Resistance 1% or less

Table 2-1
External Resistor and Variable Resistor Value
(For +/-20% Output Adjustment)

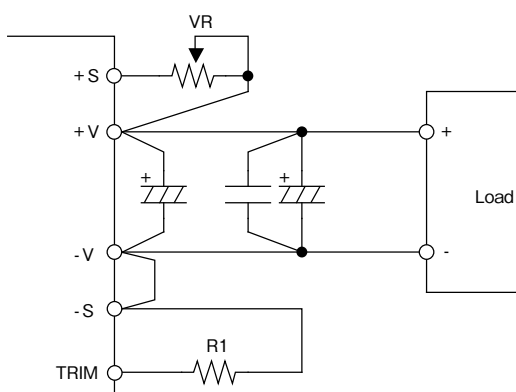

Fig. 2-1 External Resistor Connection Example

Output Voltage Adjustment by applying external voltage

By applying external voltage at the TRIM terminal, output voltage can be adjusted within the same output voltage adjustment range as the output voltage adjustment by external resistor or variable resistor. For this case, output voltage can be determined by the formula shown below.

$$\text{Output Voltage} = \text{TRIM Terminal Voltage} \times \text{Nominal Output Voltage}$$

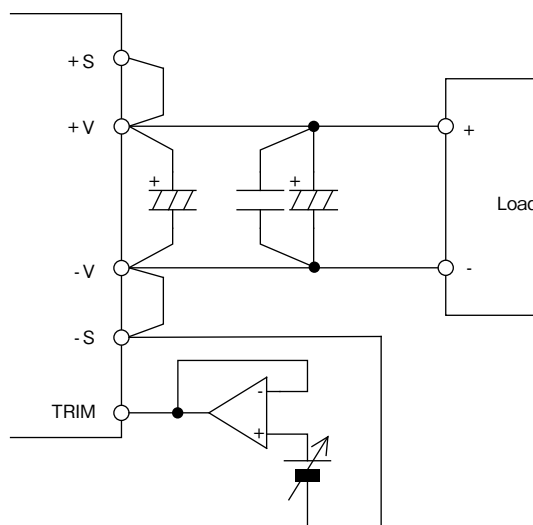

Fig. 2-2 Output Voltage Adjustment by applying external voltage

For applications other than the above, refer to the TRIM circuit as shown in fig.2-3 and determine external circuit and components values.

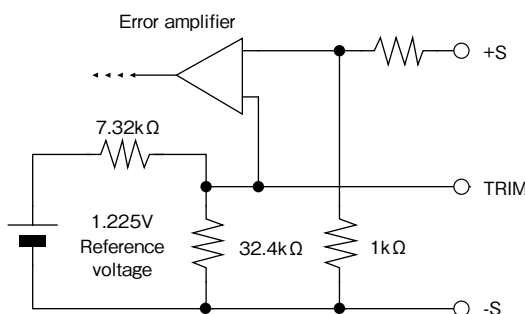

Fig.2-3 Internal TRIM Circuit (For the Reference)

3 Maximum Ripple and Noise

This value is measured according to the description below in accordance with JEITA-9131B(Section 7.16, 7.17 and 7.18).

In the basic connection shown in Fig. 1-1, additional connection shown in Fig. 3-1 is done for measurement. Capacitor (Ceramic Capacitor : 2.2μF and Electrolytic Capacitor : Refer to Table 1-2) must be connected within 50mm from the output terminals. Then, connect coaxial cable with JEITA attachment across the ceramic capacitor electrodes. Use 100MHz bandwidth oscilloscope or equivalent.

Also, note that output ripple voltage and output spike noise voltage might vary depending on the wiring pattern of the printed circuit board.

In general, output ripple voltage and output spike noise voltage can be reduced by increasing external capacitance

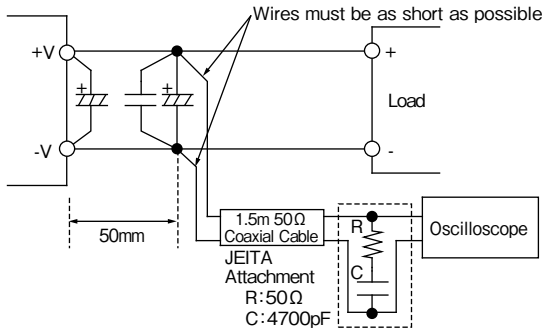

Fig. 3-1
Output Ripple Voltage (including Spike Noise)
Measurement Method

4 Maximum Line Regulation

Maximum line regulation is defined as the maximum output voltage change when input voltage is gradually changed (Steady-State) within specification range.

5 Maximum Load Regulation

Maximum load regulation is defined as the maximum output voltage change when output load current is gradually changed (Steady-State) within specification range.

When using power module in dynamic load mode, audible sound could be heard from the power module or large output voltage change might occur. Make prior evaluation thoroughly before using this power module.

6 Over Current Protection (OCP)

This module is equipped with OCP function. Constant current limiting with automatic recovery for PFE500F Series. Output will automatically recover when short circuit or overload condition is released. Constant current limiting with delay shutdown for PFE1000F Series. Output will be shutdown when output about under 70 % by short circuit or overload condition that continue about 0.5s. When the shutdown function activates, first cut off input line and verify that boost voltage has dropped down to 20V or less. Then, recover output by recycling input line. In other method, reset to ON/OFF control. OCP value is fixed and cannot be adjusted externally.

Note that continuous short circuit or overload condition more than 30s, might result in power module damage.

7 Over Voltage Protection (OVP)

This module is equipped with OVP function. This value is set between 125% to 145% of nominal output voltage. When the OVP function activates, first cut off input line and verify that boost voltage has dropped down to 20V or less. Then, recover output by recycling input line. In other method, reset to ON/OFF control. OVP value is fixed and cannot be set externally.

8 Over Temperature Protection (OTP)

This module is equipped with OTP function. This function activates and shuts down the output when ambient temperature or internal temperature abnormal rises. OTP activates at following baseplate temperature.

PFE500F-12	:	90 to 115 deg C
PFE500F-28, 48	:	105 to 130 deg C
PFE1000F-*	:	105 to 130 deg C

When OTP function operates, output can be recovered by cooling down the baseplate sufficiently and letting the boost voltage drop down to 20V or less before recycling the input line. In other method, reset to ON/OFF control.

9 Remote Sensing (+S, -S terminals)

This module has remote sensing terminals to compensate for voltage line drop from the output terminals to the output load. When remote sensing is not required, (local sensing) short +S to +V and -S to -V terminals respectively.

Note that line drop (voltage drop due to wiring) compensation voltage range must be such that the output voltage is within the output voltage adjustment range and that the voltage between -V and -S must be within 0.5V.

Consider power loss due to line drop and use power module within the maximum allowable output power. Reduce the effect of noise to the remote sensing line by using a shield line, a twist pair, or a parallel pattern, etc.

When remote sensing line is long, add the electrolytic capacitor as shown in Fig 9-1.

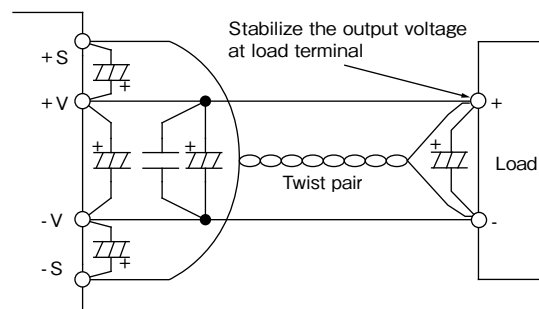

Fig. 9-1 Remote Sensing is used

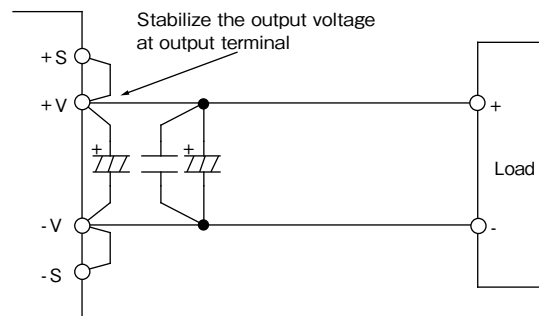

Fig. 9-2 Remote Sensing is not used (Local Sensing)

10 ON/OFF Control (+ON/OFF, -ON/OFF terminal)

This module is equipped with ON/OFF control function. Without turning the input supply on and off, the output can be enabled and disabled using this function.

The ON/OFF control circuit is isolated from input circuit of the power supply by photo-coupler.

Fig. 10-1 and Fig. 10-2 is connection example of ON/OFF control. When the ON/OFF control is not used, short +ON/OFF to AUX and -ON/OFF to COM terminals respectively.

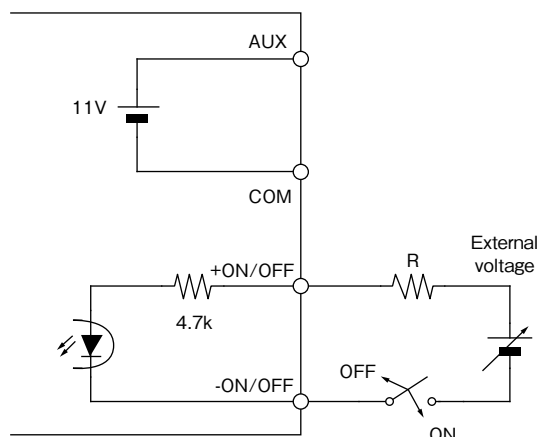

Fig. 10-1 ON/OFF Control Connection Example 1 (ON/OFF Control by External Voltage)

Select the external voltage and external resistance, as the ON/OFF terminals current is shown below.

ON/OFF terminal current	Output Voltage
2.5mA (+/-0.5mA)	ON
Less than 0.15mA	OFF

Table 10-1 Recommended ON/OFF Terminal Current

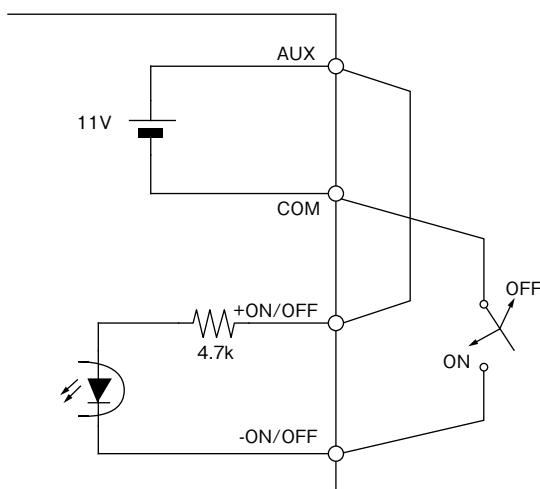

Fig. 10-2 ON/OFF Control Connection Example 2 (ON/OFF Control by Built-in AUX)

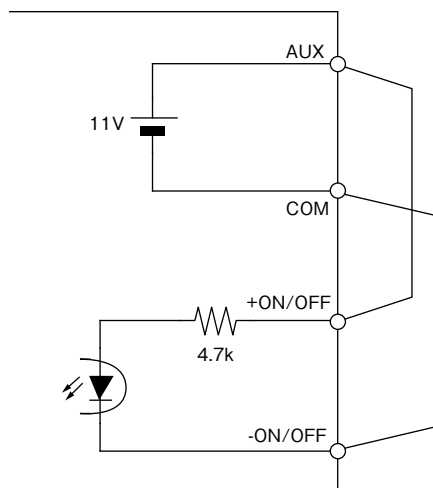

Fig. 10-3 ON/OFF Control Connection Example 3 (ON/OFF Control is not used)

11 Series Operation

Series operation is possible for PFE500F Series and PFE1000F Series. Connections shown in Fig. 11-1 and Fig. 11-2 are possible.

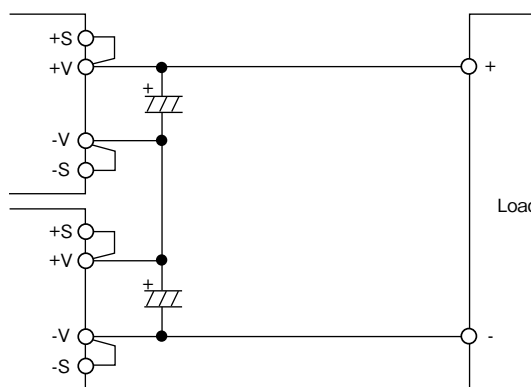

Fig. 11-1 Series Operation for High Output Voltage Applications

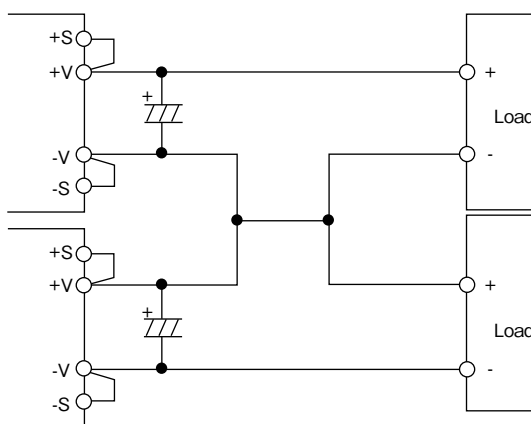

Fig. 11-2 +/- Output Series Applications

12 Parallel Operation (PC terminal)

By connecting the PC terminal of each power module, output current can be equally drawn from each module. A maximum of 6 units of the same model can be connected.

However, maximum output current is derated by parallel operation units as shown in Table 12-1.

Note that usage of power module at out-of-rated condition might result in power module temperature abnormal rise or damage.

Parallel units	Maximum output current
~ 3 units	90% of nominal output current
4 ~ 6 units	85% of nominal output current

Table 12-1 Condition for Parallel Operation

Set the accuracy of the output voltage within +/-1% when adjust the output voltage for parallel operation.

When adjust the output voltage by applying external voltage at the TRIM terminal, insert a about 10k ohm resistor between TRIM terminal and external source.

Moreover, external circuits are necessary for TRIM terminal at each individual module.

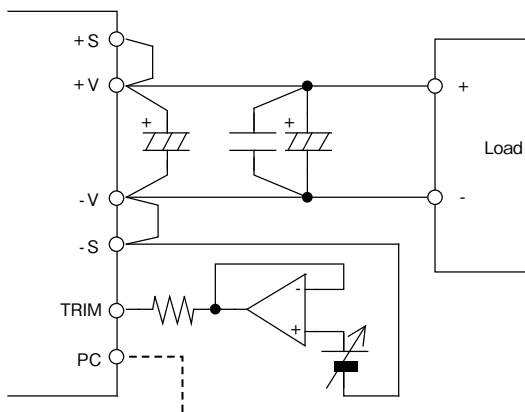

Fig. 12-1 Output Voltage Adjustment by applying external voltage (For parallel operation)

At parallel operation, +BC, -BC and R terminals must not be connected in parallel with other modules. It might result in power module damage.

Refer to "Parallel Operation" of the PH-Series Application Notes for details.

13 Power ON Signal (ENA terminal)

This signal is located at the secondary side (output side) and it is an open collector output. (Maximum sink current is 10mA and maximum applied voltage is 75V.)

Return line for ENA terminal is the COM terminal.

When output voltage goes over a specified voltage level at start up, Power ON signal is LOW.

Output voltage threshold level is as follows.

- PFE500F·1000F-12 : 8V (TYP)
- PFE500F·1000F-28 : 19V (TYP)
- PFE500F·1000F-48 : 33V (TYP)

On the other hand, output voltage threshold level for Power ON signal to turn HIGH is as follows.

- PFE500F·1000F-12 : 6V (TYP)
- PFE500F·1000F-28 : 15V (TYP)
- PFE500F·1000F-48 : 28V (TYP)

14 I.O.G signal (IOG terminal)

Normal or abnormal operation of the power module can be monitored by using the IOG terminal. Output of this signal monitor is located at secondary side (output side) and is an open collector output.

This signal is LOW when inverter is normally operating and HIGH when inverter stops or when inverter is operating abnormally. (maximum sink current is 5mA, maximum applied voltage is 35V)

Ground for the IOG terminal is the COM terminal.

Also note that IOG becomes unstable for following conditions:

- Operation of Over Current Protection (OCP)
- Light load conditions at parallel operation
- Dynamic load operation

15 Auxiliary power supply for external circuits (AUX terminal)

For AUX terminal, output voltage value is within 10 ~ 14VDC range, maximum output current is 20mA. Ground for the AUX terminal is COM terminal.

Avoid short circuit of AUX terminal with other terminals as this would lead to power module damage.

16 Operating Temperature Range

These products can be used in any mounting direction but be sure to consider enough airflow to avoid heat accumulation around the module.

Consider surrounding components layout and set the PCB mounting direction such that air can flow through the heat-sink by forced or convection cooling .

This product can operate at actual mounting condition when baseplate temperature is maintained at or below the following baseplate temperature.

- PFE500F-12 : 85°C
- PFE500F-28,48 : 100°C
- PFE1000F-12 : 100°C
- PFE1000F-28,48 : 85°C (85VAC ≤ Vin < 170VAC)
- 100°C (170VAC ≤ Vin ≤ 265VAC)

Verify baseplate temperature at worst case operating condition at the measuring point as shown in Fig. 16-1.

For Thermal Design details, refer to Power Module Application Notes "Thermal Design" section.

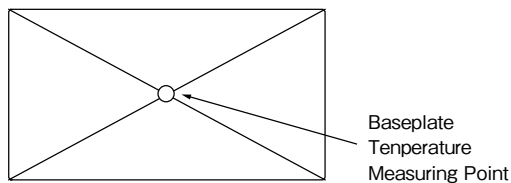

Fig. 16-1 Baseplate Measuring Point

Baseplate temperature range is limited according to Fig. 16-2.

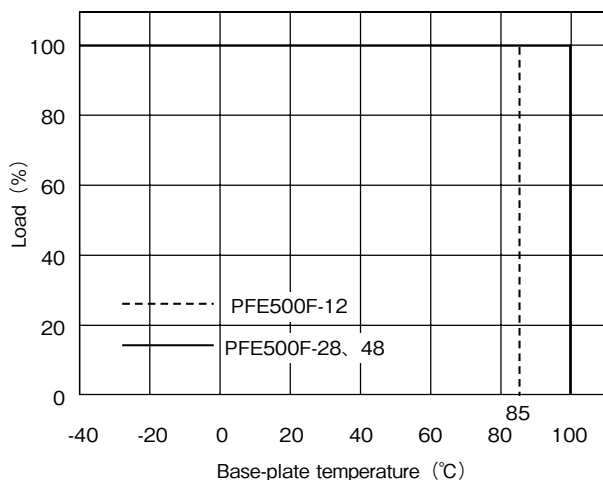

Fig. 16-2-(1) PFE500F Series Derating Curve

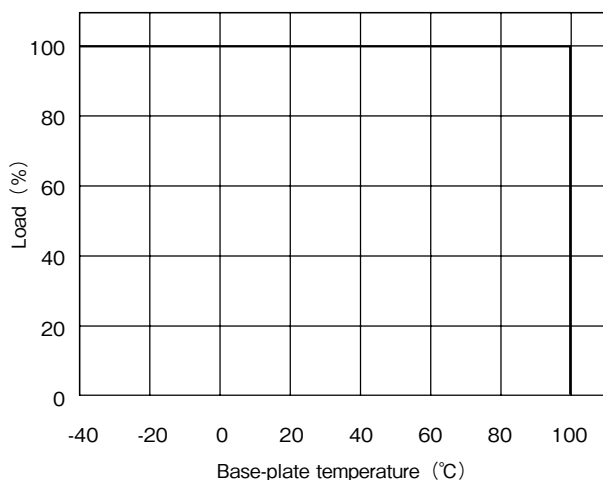

Fig. 16-2-(2) PFE1000F-12 Derating Curve

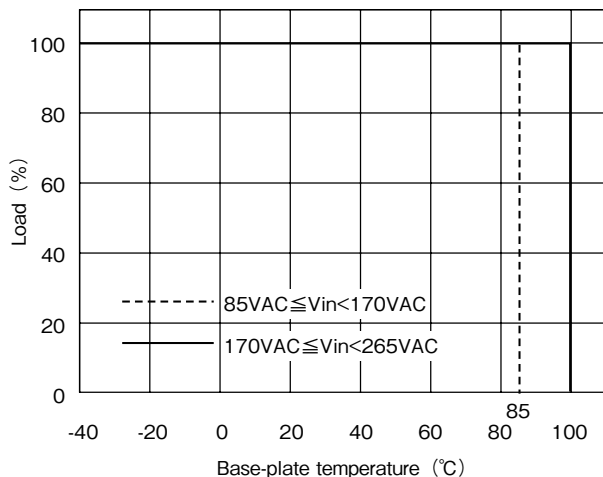

Fig. 16-2-(3) PFE1000F-28,48 Derating Curve

To further improve the reliability, it is recommended to use this module with baseplate temperature derating.

17 Operating Humidity

Note that dewdrop might cause power module abnormal operation or damage.

18 Storage Temperature

Note that rapid temperature change causes dewdrop causing harmful effect on soldering condition of the terminal pins.

19 Storage Humidity

Storage under high temperature and high humidity causes rust on terminal pins that causes deterioration of soldering conditions. Take enough caution when storing this module.

20 Cooling Method

For details of thermal design, refer to Power Module Application Notes "Thermal Design" section.

21 Withstand Voltage

This module is designed to withstand applied voltage 2.5kVAC between input and baseplate, 3kVAC between input and output for a duration of 1 minute. When doing this test during incoming inspection, set the current limit of test equipment to 20mA.

This module is designed to withstand applied voltage 500VDC between output and baseplate for 1 minute. When doing this test during incoming inspection, be sure to apply DC voltage only. Avoid applying AC voltage during this test because this will damage the module.

Refrain from injecting high test voltage suddenly. Be sure to gradually increase the applied voltage during testing and gradually reduce the voltage after the test.

Especially, when using timer switch of the test equipment, impulse voltage which is higher than the applied set voltage, is generated when the timer switch is cut off. This causes damage to the power module. Connect each terminal according to the circuit diagram shown below.

For basic connection shown in Fig. 1-1, do the same terminal connections.

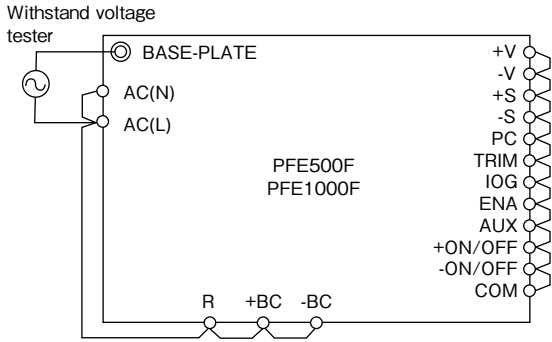

2.5kVAC 1 minute (20mA)
Fig. 21-1 Input to Baseplate Withstand Voltage Test Method

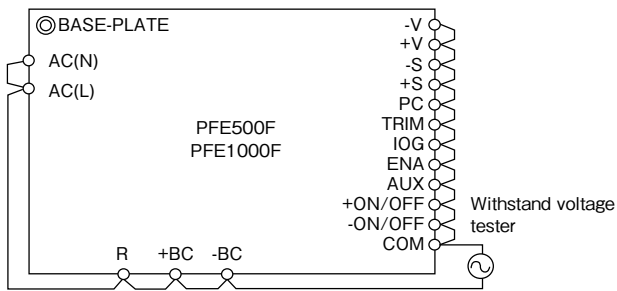

3kVAC 1 minute (20mA)
Fig.21-2 Input to Output Withstand Voltage Test Method

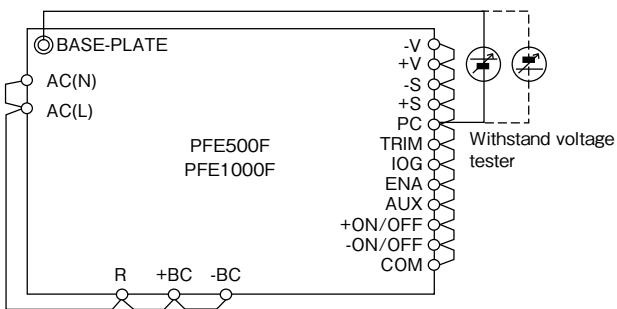

500VDC 1 minute
Fig.21-3 Output to Baseplate Withstand Voltage Test Method

22 Insulation Resistance

Use DC Insulation Resistance test equipment (MAX.500V) between output and baseplate.

Insulation Resistance must be 100Mohm or more at 500VDC. Take caution that some types of test equipment generate high pulse voltage when switching applied voltage. After test, discharge this module using resistor, etc.

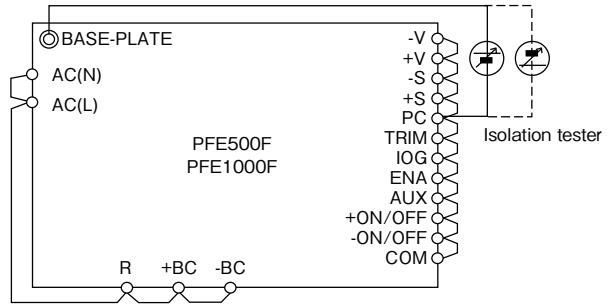

100Mohm or more at 500VDC
Fig. 22-1 Insulation Resistance Test Method

23 Recommended Soldering Condition

Recommended soldering temperature is as follows.

- (1) Soldering Dip : 260°C , within 10 seconds
 Preheat : 130°C , within 60 seconds
- (2) Soldering iron : 350°C , within 3 seconds

3. Before Concluding Power Module Damage

Verify following items before concluding power module damage.

- 1) No output voltage
 - Is specified input voltage applied?
 - During output voltage adjustment, is the fixed resistor or variable resistor setting correct?
 - Is there no abnormality with the output load?
 - Is the actual baseplate temperature within the specified operating temperature of this module?
 - Are the ON/OFF control terminals (+ON/OFF,-ON/OFF) correctly connected?
- 2) Output voltage is high
 - Are the remote sensing terminals (+S, -S) correctly connected?
 - Is the measurement done at the sensing points?
 - During output voltage adjustment, is the fixed resistor or variable resistor setting correct?
- 3) Output voltage is low
 - Is specified input voltage applied?
 - Are the remote sensing terminals (+S, -S) correctly connected?
 - Is the measurement done at the sensing points?
 - During output voltage adjustment, is the fixed resistor or variable resistor setting correct?
 - Is there no abnormality with the output load?
- 4) Load regulation or line regulation is large
 - Is specified input voltage applied?
 - Are the input or output terminals firmly connected?
 - Is the measurement done at the sensing points?
 - Are the input and output wires too thin?
- 5) Large output ripple
 - Is the measurement done according to methods described Application Notes or is it an equivalent method?

Option Standard heat sinks

■ Heat sink for [PFE500F](HAL-F12T)

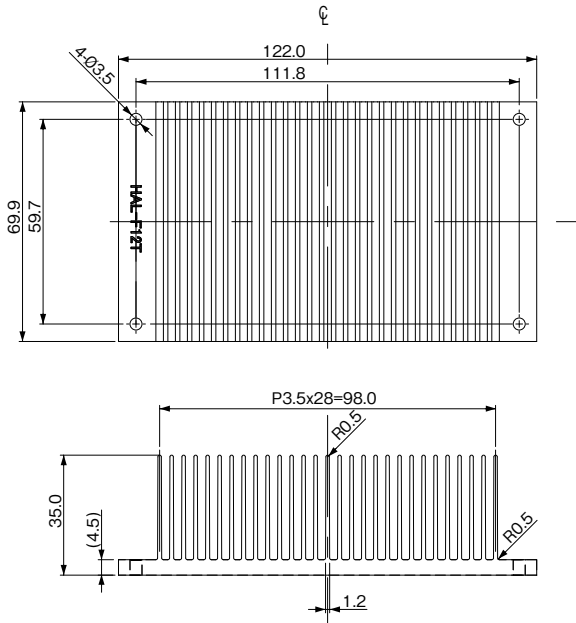

■ Heat sink for [PFE1000F](HAM-F10T)

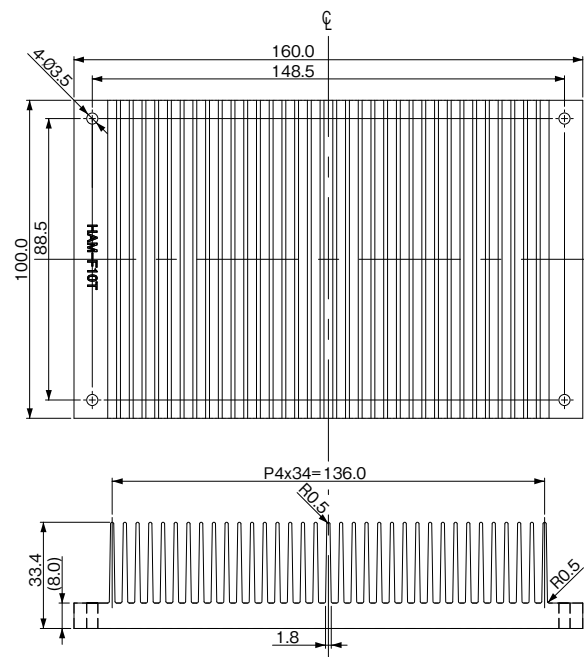

■ Adaptation

Model	Size (W×H×Dmm)	Standard heat sinks	Thermal resistance
PFE500F	122×35×69.9	HAL-F12T	0.97°C / W
PFE1000F	160×33.4×100	HAM-F10T	0.78°C / W

PFE-S SERIES

Single Output AC-DC Power Module

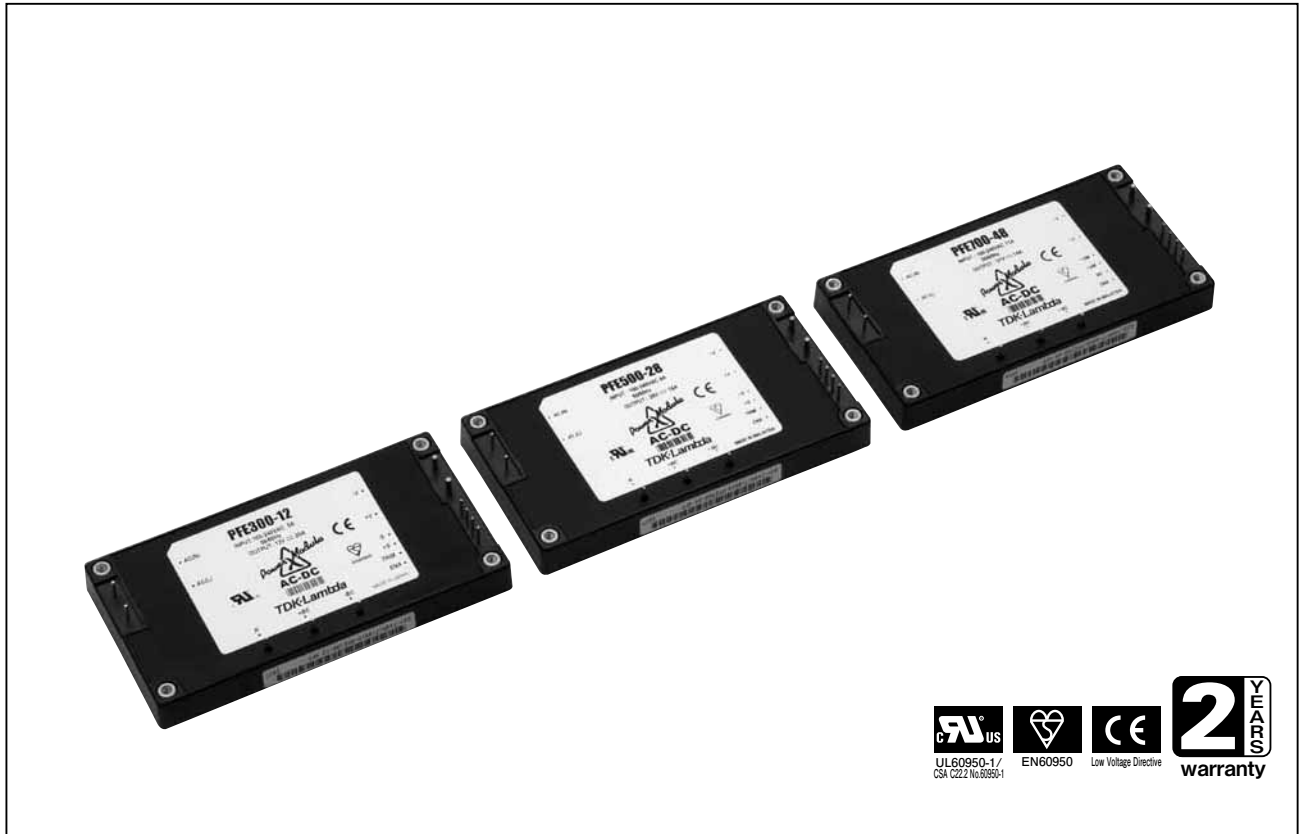

■ Features

- PFHC and DC/DC conversion integrated into a full brick package
- Wide input voltage range: 85-265VAC
- High power factor: 0.95, meeting PFHC standard (EN61000-3-2)
- High efficiency: 86% max (PFE300S,500S), 89% max (PFE700S)
- Wide operating temperature
Baseplace temperature: -40°C to +100°C
- Stable output voltage type (PFE300S,500S) and high power semi-regulated type (PFE700S) in the line-up
- Parallel operation supported (PFE700S only)
- Built-in capacitor: Ceramic type only (high reliability)

■ Applications

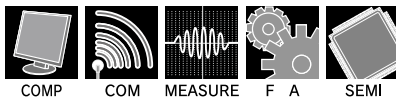

■ Product Line up

PFE-S. (AC85-265Vin)

Output Voltage	300W		500W		700W	
	Output Current	Model	Output Current	Model	Output Current	Model
12V	25A	PFE300S-12	33A	PFE500S-12	—	—
28V	10.8A	PFE300S-28	18A	PFE500S-28	—	—
48V	6.3A	PFE300S-48	10.5A	PFE500S-48	—	—
50-57V (Semi-regulated)	—	—	—	—	14A	PFE700S-48

Note) PFE300S/PFE500S are of the stable output voltage type, and they are constant-voltage power supplies as they are. PFE700S is of the semi-regulated type, and a multiple-output power supply can be configured by connecting other multiple DC/DC converters on the back of PFE700S.

• All contents are subject to change without notice.

■ Model naming method

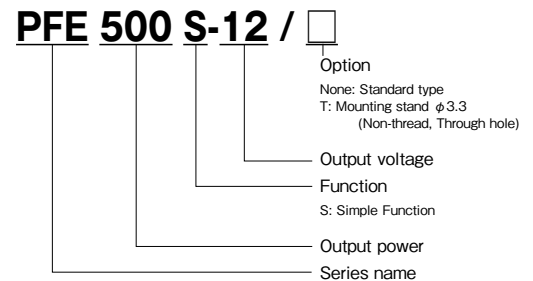

■ Conformity to RoHS Directive

This means that, in conformity with EU Directive 2002/95/EC, lead, cadmium, mercury, hexavalent chromium, and specific bromine-based flame retardants, PBB and PBDE, have not been used, except for exempted applications.

PFE300S Specifications

ITEMS/UNITS		MODEL	PFE300S-12	PFE300S-28	PFE300S-48
Input	Voltage Range (*2)(*5)	V	AC85 - 265		
	Frequency (*2)	Hz	47 - 63		
	Power Factor (min) (*1)(*5)		0.95		
	Efficiency (typ) (*1)	%	81 / 83	83 / 85	
	Current (*1)	A	4.0 / 2.0		
	Inrush Current (typ) (*1)(*5)	A	20 / 40 peak		
Output	Nominal Voltage (*1)	VDC	12	28	48
	Maximum Current	A	25	10.8	6.3
	Maximum Power	W	300	302.4	
	Voltage Setting Accuracy	%	±2		
	Maximum Line Regulation	mV	48	56	96
	Maximum Load Regulation	mV	48	56	96
	Maximum Ripple Voltage (*5)	mVp-p	120	280	480
	Voltage Adjustable Range		-20% / +20%		
Function	Over Current Protection		105% - 140% (Automatic recovery method)		
	Over Voltage Protection		125% - 145% (Inverter shutdown method)		
	Parallel Operation		-		
	Series Operation (*6)		Possible		
Environment	Operating Temperature (*3)(*7)	°C	-40 to +100 (Baseplate)		
	Storage Temperature	°C	-40 to +100		
	Operating Humidity	%RH	20 - 95 (No dewdrop)		
	Storage Humidity	%RH	10 - 95 (No dewdrop)		
	Vibration		At no operating, 10-55Hz (sweep for 1min.) Amplitude 0.825mm constant (maximum 49.0m/s ²) X, Y, Z 1 hour each		
	Shock		196.1m/s ²		
	Cooling (*4)		Conduction cooled		
Isolation	Withstand Voltage		Input-Baseplate : 2.5kVAC, Input-Output : 3.0kVAC for 1min. Output-Baseplate : 1.5kVDC for 1min.		
	Isolation Resistance		Output to Baseplate 500VDC more than 100MΩ (25°C, 70%RH)		
Standards	Safety Standards		Approved by UL60950-1, CSA C22.2 No.60950-1, EN60950-1		
Mechanical	Weight (typ)	g	250		
	Size (W x H x D)	mm	61 x 12.7 x 116.8 (Refer to outline drawing.)		

(*1) At 100VAC/200VAC and maximum output power. (Baseplate temperature = +25°C.)

(*2) For cases where conformance to various safety specs (UL, CSA, EN) are required, input voltage range will be 100 - 240VAC (50/60Hz).

(*3) Ratings - refer to derating curve below.

(*4) Heatsink has to be chosen according to instruction manual.

(*5) External components are needed for operation. (Refer to basic connection and instruction manual.)

(*6) Refer to instruction manual.

(*7) Ambient temperature min=-40°C

Derating Curve

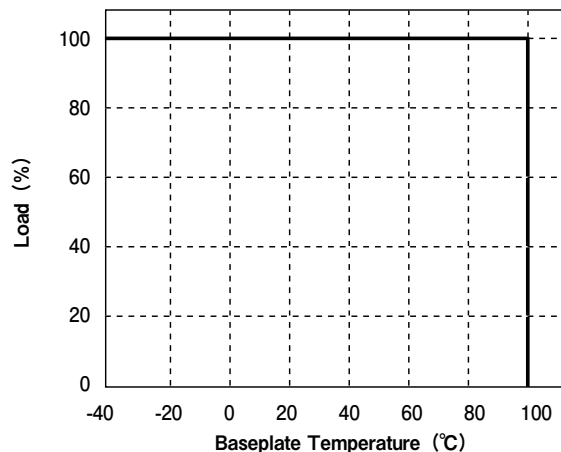

PFE500S Specifications

ITEMS/UNITS		MODEL	PFE500S-12	PFE500S-28	PFE500S-48
Input	Voltage Range	(*2)(*5) V	AC85 - 265		
	Frequency	(*2) Hz	47 - 63		
	Power Factor (min)	(*1)(*5)	0.95		
	Efficiency (typ)	(*1) %	82 / 83	84 / 86	
	Current	(*1) A	5.0 / 3.0		6.2 / 3.2
	Inrush Current (typ)	(*1)(*5) A	20 / 40 peak		
Output	Nominal Voltage	(*1) VDC	12	28	48
	Maximum Current	A	33	18	10.5
	Maximum Power	W	396	504	
	Voltage Setting Accuracy	%	±2		
	Maximum Line Regulation	mV	48	56	96
	Maximum Load Regulation	mV	48	56	96
	Maximum Ripple & Noise (*5)	mVp-p	120	280	480
	Voltage Adjustable Range		-20% / +20%		
Function	Over Current Protection		105% - 140% (Automatic recovery method)		
	Over Voltage Protection		125% - 145% (Inverter shutdown method)		
	Parallel Operation		-		
	Series Operation	(*6)	Possible		
Environment	Operating Temperature(*3)(*7)	°C	-40 to +85 (Baseplate)	-40 to +100 (Baseplate)	
	Storage Temperature	°C	-40 to +100		
	Operating Humidity	%RH	20 - 95 (No dewdrop)		
	Storage Humidity	%RH	10 - 95 (No dewdrop)		
	Vibration		At no operating, 10-55Hz (sweep for 1min.) Amplitude 0.825mm constant (maximum 49.0m/s ²) X, Y, Z 1 hour each		
	Shock		196.1m/s ²		
	Cooling	(*4)	Conduction cooled		
Isolation	Withstand Voltage		Input-Baseplate : 2.5kVAC, Input-Output : 3.0kVAC for 1min. Output-Baseplate : 1.5kVDC for 1min.		
	Isolation Resistance		Output to Baseplate 500VDC more than 100MΩ (25°C, 70%RH)		
Standards	Safety Standards		Approved by UL60950-1, CSA C22.2 No.60950-1, EN60950-1		
Mechanical	Weight (typ)	g	250		
	Size (W x H x D)	mm	61 x 12.7 x 116.8 (Refer to outline drawing.)		

- (*1) At 100VAC/200VAC and maximum output power. (Baseplate temperature = +25°C.)
- (*2) For cases where conformance to various safety specs (UL, CSA, EN) are required, input voltage range will be 100 ~ 240VAC (50/60Hz).
- (*3) Ratings - refer to derating curve on the right.
- (*4) Heatsink has to be chosen according to instruction manual.
- (*5) External components are needed for operation. (Refer to basic connection and instruction manual.)
- (*6) Refer to instruction manual.
- (*7) Ambient temperature min=-40°C

Derating Curve

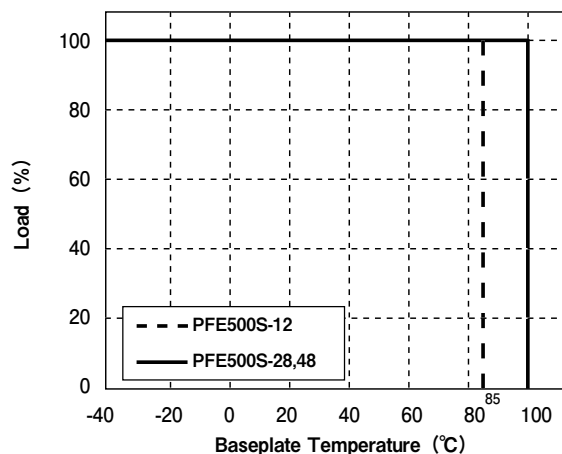

Outline Drawing

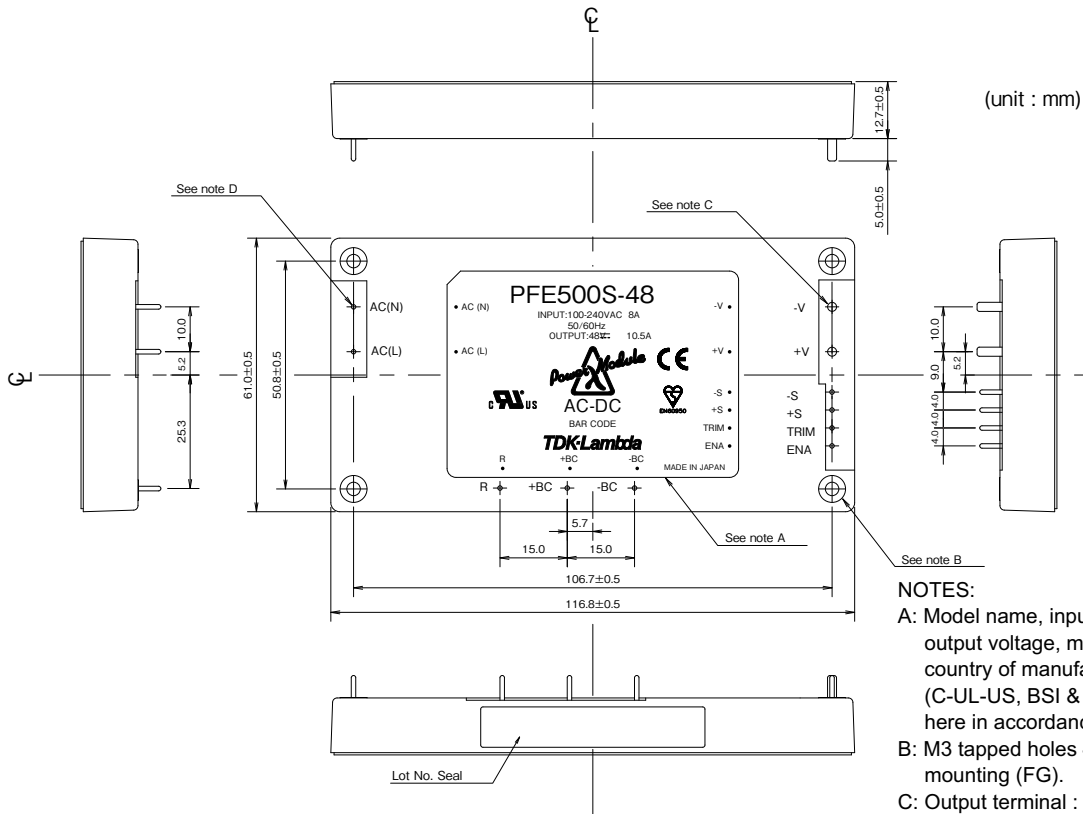

- NOTES:**
- A: Model name, input voltage range, nominal output voltage, maximum output current, country of manufacture and safety marking (C-UL-US, BSI & CE marking) are shown here in accordance with the specifications.
 - B: M3 tapped holes 4 for customer chassis mounting (FG).
 - C: Output terminal : 2-Φ2
 - D: Input, Intermediate terminal and signal pin: 9-Φ1
 - E: Unless otherwise specified dimensional tolerance : ±0.3

Basic Connection

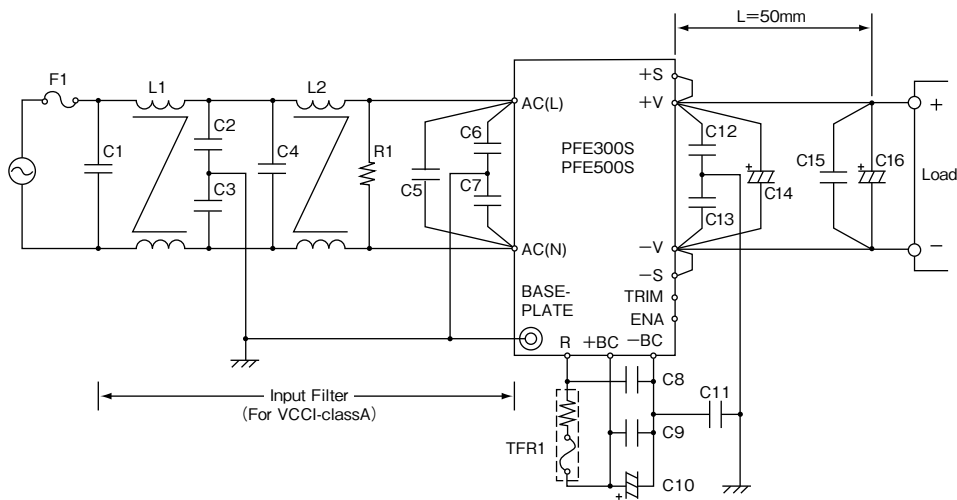

F1	AC250V 15A	C9	450V 1uF (Film)	C15	100V 2.2uF (Ceramic)
C1	AC250V 1uF (Film)	C10	PFE300S:450V 470uF x1 (Elec.) PFE500S:450V 390uF x2 (Elec.)	C16	12V: 25V 1000uF (Elec.) 28V: 50V 470uF (Elec.) 48V: 100V 220uF (Elec.)
C2	4700pF	C11	1000pF	R1	2W 470kΩ
C3	4700pF	C12	0.033uF	TFR1	10Ω 139°C (Res., Thermal fuse)
C4	AC250V 1uF (Film)	C13	0.033uF	L1	6mH
C5	AC250V 1uF (Film)	C14	12V: 25V 1000uF (Elec.) 28V: 50V 470uF (Elec.) 48V: 100V 220uF (Elec.)	L2	6mH
C6	1000pF				
C7	1000pF				
C8	450V 1uF (Film)				

Note: Except C10, above components list is for both PFE300S and PFE500S Series
Please select component standards, withstand voltage, etc based on the application.

PFE700S Specifications

ITEMS/UNITS		MODEL	PFE700S-48
Input	Voltage Range	(*2)(*5) V	AC 85 - 265
	Frequency	(*2) Hz	47 - 63
	Power Factor (min)	(*1)(*5)	0.95
	Efficiency (typ)	(*1) %	86 / 89
	Current	(*1) A	8.8 / 4.4
	Inrush Current (typ)	(*1)(*5) A	20 / 40 peak
Output	Nominal Voltage	(*1) VDC	51
	Voltage Regulation Range (*7)	V	50 - 57
	Maximum Current	A	14
	Maximum Power	W	714
	Voltage Setting Accuracy (*1)		±1 V
	Maximum Ripple & Noise (*5)		4 Vp-p
Function	Over Current Protection		105% - 140% (Automatic recovery method)
	Over Voltage Protection	VDC	60.0 - 69.6 (Inverter shutdown method)
	Parallel Operation (*6)		Possible
	Series Operation (*6)		Possible
Environment	Operating Temperature (*3)	°C	-40 to +100 (Baseplate), Ambient temperature min=-40°C
	Storage Temperature	°C	-40 to +100
	Operating Humidity	%RH	20 - 95 (No dewdrop)
	Storage Humidity	%RH	10 - 95 (No dewdrop)
	Vibration		At no operating, 10-55Hz (sweep for 1min.) Amplitude 0.825mm constant (maximum 49.0m/s ²) X, Y, Z 1 hour each
	Shock		196.1m/s ²
	Cooling (*4)		Conduction cooled
Isolation	Withstand Voltage		Input-Baseplate : 2.5kVAC, Input-Output : 3.0kVAC for 1min. Output-Baseplate : 1.5kVDC for 1min.
	Isolation Resistance		Output to baseplate 500VDC more than 100MΩ (25°C, 70%RH)
Standards	Safety Standards		Approved by UL60950-1, CSA C22.2 No.60950-1, EN60950-1
Mechanical	Weight (typ)	g	250
	Size (W x H x D)	mm	61 x 12.7 x 116.8 (Refer to outline drawing.)

(*1) At 100VAC/200VAC and maximum output power. (Baseplate temperature = +25°C.)

(*2) For cases where conformance to various safety specs (UL, CSA, EN) are required, input voltage range will be 100 ~ 240VAC (50/60Hz).

(*3) Ratings - refer to Derating Curve on the right.

(*4) Heatsink has to be chosen according to Instruction manual.

(*5) External components are needed for operation. (Refer to basic connection and instruction manual.)

(*6) Refer to Instruction manual.

(*7) For all input voltage, output load and temperature range.

Derating Curve

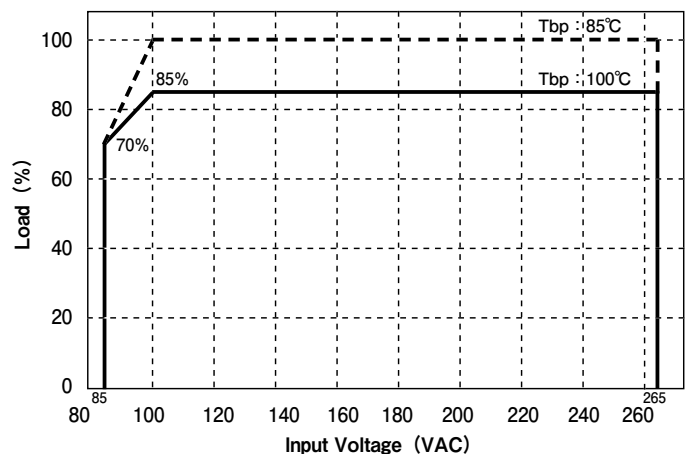
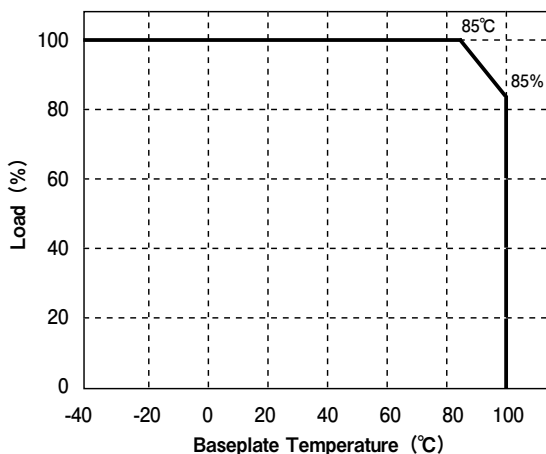

Outline Drawing

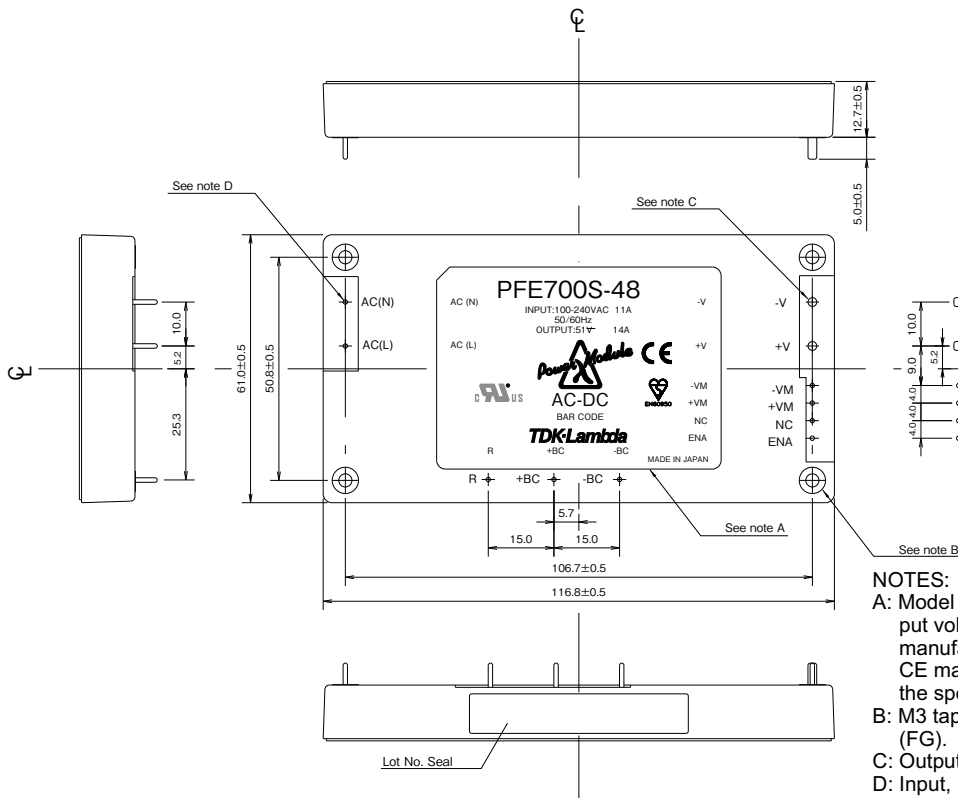

- NOTES:**
- A: Model name, input voltage range, Nominal output voltage, Maximum output current, country of manufacture and safety marking (C-UL-US, BSI & CE marking) are shown here in accordance with the specifications.
 - B: M3 tapped holes 4 for customer chassis mounting (FG).
 - C: Output terminal : 2-Φ2
 - D: Input, Intermediate terminal and signal pin: 9-Φ1 (NC : Make no external connection)
 - E: Unless otherwise specified dimensional tolerance : ±0.3

Basic Connection

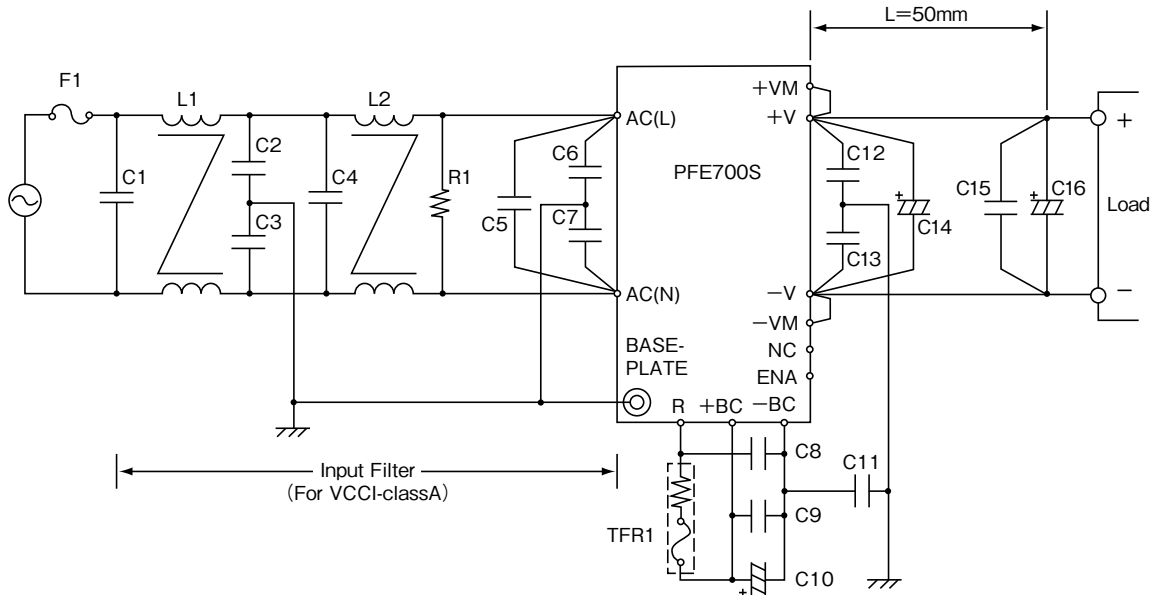

F1	AC250V 15A	C7	1000pF	C14	48V: 100V 220uF (Elec.)
C1	AC250V 1uF (Film)	C8	450V 1uF (Film)	C15	100V 2.2uF (Ceramic)
C2	4700pF	C9	450V 1uF (Film)	C16	100V 220uF (Elec.)
C3	4700pF	C10	450V 390uF x2 Parallel (Elec.)	R1	2W 470kΩ
C4	AC250V 1uF (Film)	C11	1000pF	TFR1	10Ω 139°C (Res., Thermal fuse)
C5	AC250V 1uF (Film)	C12	0.033uF	L1	6mH
C6	1000pF	C13	0.033uF	L2	6mH

Note: Please select component standards, withstand voltage, etc based on the application.

Block Diagram

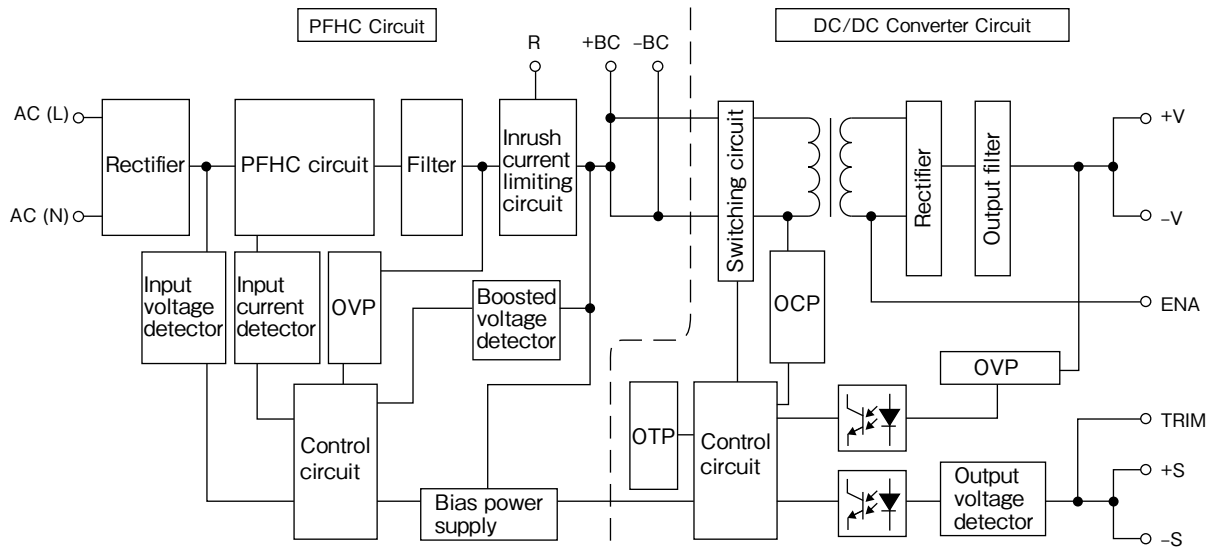

Switching Frequency
 PFHC circuit (fixed) : 100kHz
 DC/DC converter (fixed) : 230kHz (primary), 460kHz (secondary)

Sequence Time Chart

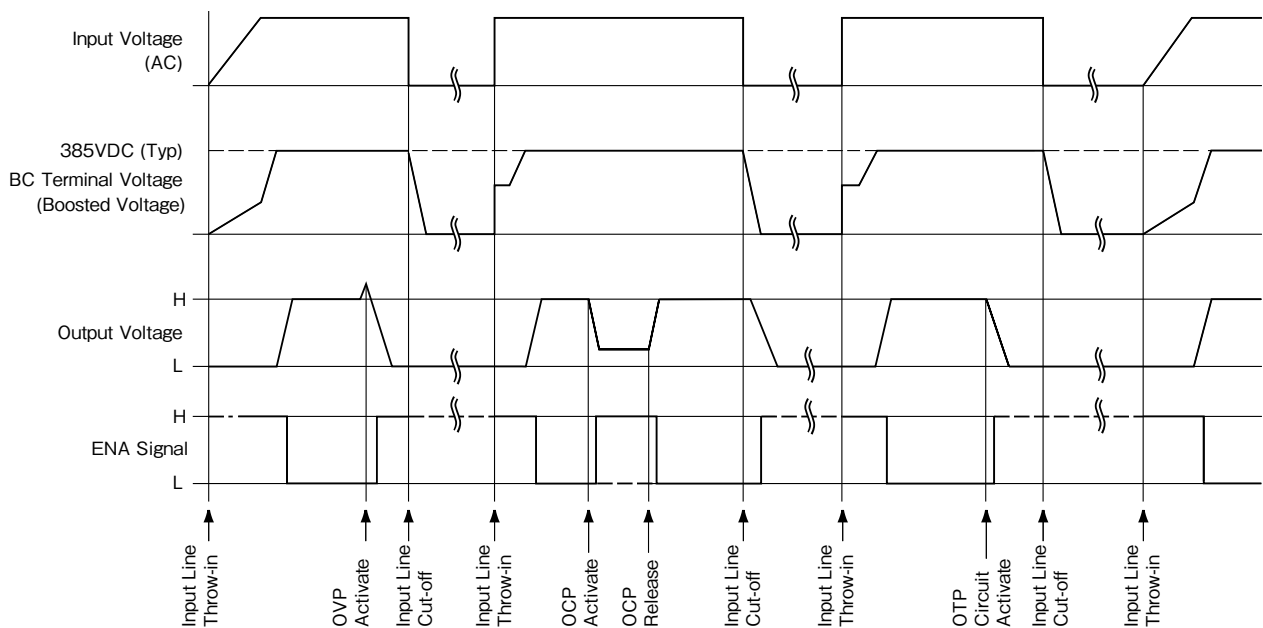

Note : This product has no remote ON/OFF function.

Block Diagram

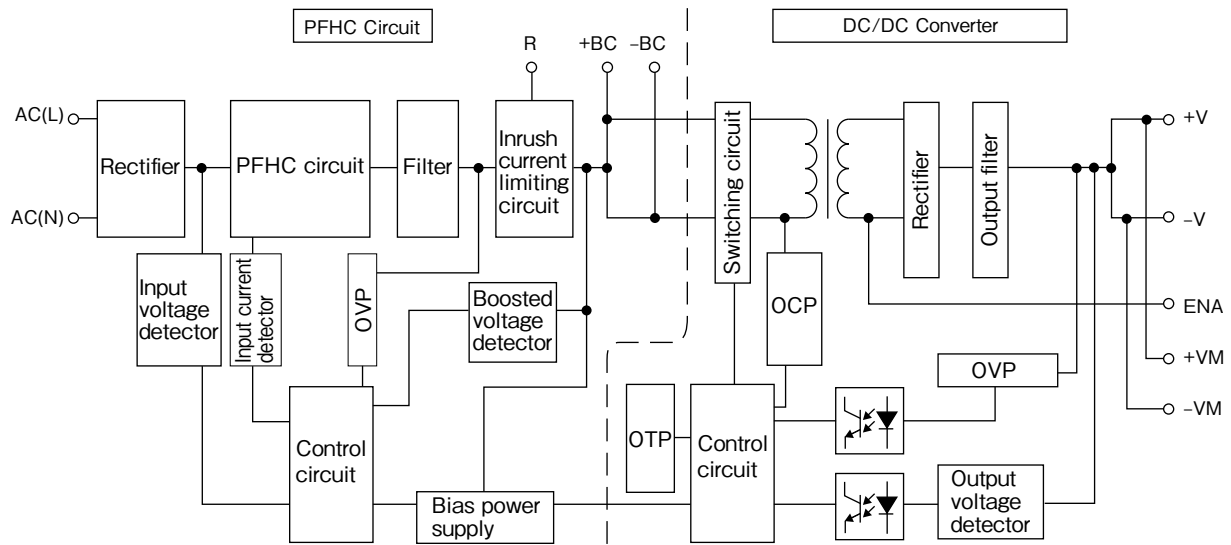

Switching Frequency
 PFHC circuit (fixed) : 100kHz
 DC/DC converter (fixed) : 180kHz (primary), 360kHz (secondary)

Sequence Time Chart

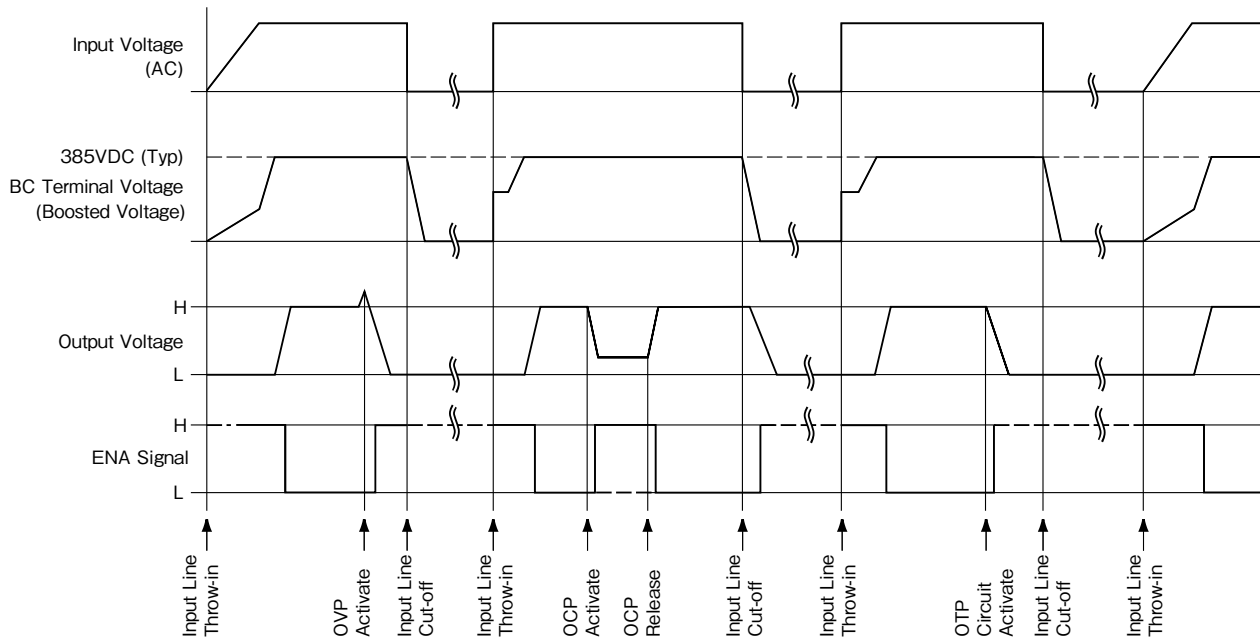

Note : This product has no remote ON/OFF function.

PFE300S, 500S Instruction Manual

BEFORE USING THE POWER SUPPLY UNIT

Be sure to read this instruction manual thoroughly before using this product. Pay attention to all cautions and warnings before using this product. Incorrect usage could lead to an electrical shock, damage to the unit or a fire hazard.



WARNING

- Do not make unauthorized changes to power supply unit, otherwise you may have electric shock and void your warranty.
- Do not touch this unit and the internal components in operation or shortly after shut down. They may have high voltage or high temperature and as the unit dissipates its heat so the surface of the unit is hot. You may receive electric shock or burn.
- When the unit is operating, keep your hands and face away from it; you may be injured by an accident
- Do not use unit under unusual condition such as emission of smoke or abnormal smell and sound etc. It might cause fire and electric shock. In such case, please contact us; do not repair by yourself, as it is dangerous for the user.
- Do not drop or insert anything into unit. It might cause failure and fire.
- Do not operate these units under condensation condition. It may cause fire and electric shock.



CAUTION

- As a component part, compliance with the standard will be based upon installation in the final application. This product must be installed in a restricted access location, accessible to authorized competent personnel only. These AC to DC converters have reinforced insulation between the input and the output. The outputs of these products are energy hazards. All models with an output greater than 48V model are considered to be non-SELV. As such, the instructions for use must refer to these energy hazardous outputs and Non-SELV outputs in that the outputs must not be accessible to the operator. The installer must also provide protection against inadvertent contact by a service engineer.
- The equipment has been evaluated for use in a Pollution Degree 2 environment.
- This power supply is primarily designed and manufactured to be used and enclosed in other equipment.
- Confirm connections to input/output terminals and signal terminals are correct as indicated in the instruction manual.
- Attach an HBC external fuse to each module to ensure safety operation and compliance to each safety standard approval. The recommended input fuse rating within the instructions is as follows: -15AHBC, 250V fast acting fuse. The breaking capacity and voltage rating of this fuse may be subject to the end use application.

- Input voltage, output current, output power, ambient temperature and ambient humidity should be used within specifications, otherwise the unit will be damaged.
- For application equipment, which requires very high reliability (nuclear related equipment, traffic control equipment, medical equipment, etc.), please provide fail safety function in the equipment.
- Do not use the product in environment with strong electromagnetic field, corrosive gas and conductive substance.
- Do not operate and store this unit at an environment where condensation occurs. In such case, waterproof treatment is necessary
- Never operate the unit under over current or shorted conditions for 30 seconds or more and out of Input Voltage Range as specification. Insulation failure, smoking, burning or other damage may occur to the unit.
- The output voltage of this power supply unit is considered to be a hazardous energy level. (The voltage is 2V or more and the electric power is 240VA or more.) Prevention from direct contact with output terminal is highly necessary. While installing or servicing this power supply unit, avoid dropping tools by mistake or direct contact with output terminal. This might cause an electric shock. While repairing this power supply unit, the AC input power must be switched off and the input and output voltage should be level.
- To maintain the SELV output for outputs less than 28VDC, under fault conditions, the output must be connected to earth in the final application.
- The application circuits and their parameter are for reference only. Be sure to verify effectiveness of application circuits and their parameters before finalizing circuit design.
- Do not inject abnormal voltage to output terminal and signal terminal from the outside. The injection of reverse voltage or over voltage exceeding nominal output voltage to output terminals might cause damage to internal components.
- This information in this document is subject to change without prior notice. For actual design-in, please refer to the latest publications of data sheet, etc., for the most up-to-date date specifications of the unit.
- No part of this document may be copied or reproduced in any form without prior written consent of TDK-Lambda.

Note : CE MARKING

CE Marking when applied to a product covered by this handbook indicates compliance with the low voltage directive (2006/95/EC) in that it complies with EN60950-1.

1. Terminal Explanation

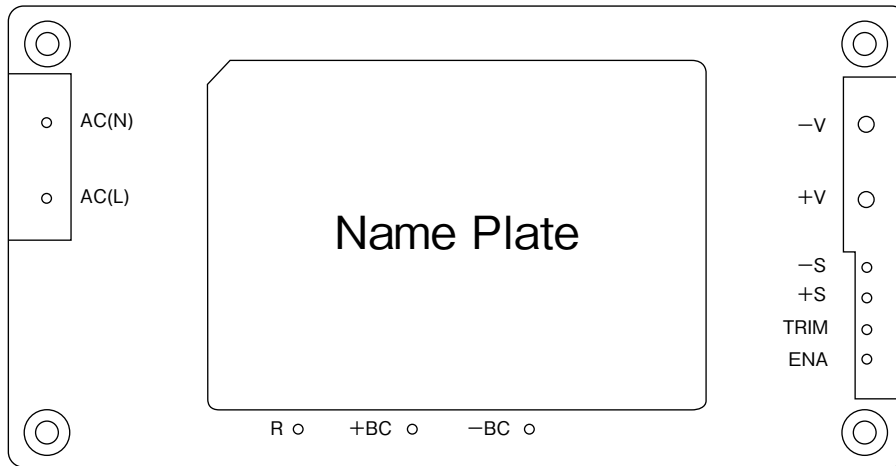

[Input side terminals]

AC(L) : Input terminal live line
 AC(N) : Input terminal neutral line

+BC : +Boosted voltage terminal
 -BC : -Boosted voltage terminal
 R : External inrush current limiting resistor

[Output side terminals]

+V : +Output terminal
 -V : -Output terminal
 +S : +Remote sensing terminal
 -S : -Remote sensing terminal
 TRIM : Output voltage trimming terminal
 ENA : Power on signal terminal

- Baseplate can be connected to FG through M3 mounting tapped holes.
- Consider contact resistance when connecting AC(L), AC(N), R, +BC, -BC, +V, -V.
- Note that +BC and -BC terminals is a primary voltage with high voltage (385VDC). Do not connect load from these terminals.

2. Explanations on Specifications

This manual explains based on "Fig.1-1 Basic Connection".
 Please do actual evaluation when changing circuit from Fig.1-1.

1 Input Voltage Range

Input voltage range is indicated below. Take care not to apply input voltage which is out of this specified range nor should a DC input voltage be applied as this would result into power module damage.

Input Voltage Range: Single Phase 85 to 265VAC
 Line Frequency Range: 47 to 63Hz

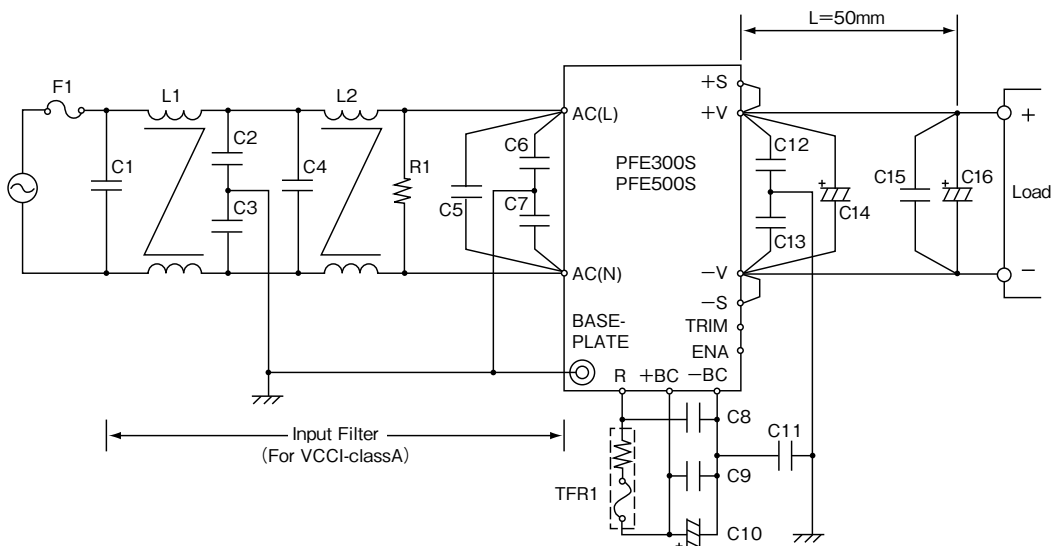

Fig. 1-1 Basic Connection

F1: External Input Fuse

This power module has no internal fuse. Use external fuse to acquire each safety standard and to further improve safety. Further, Fast-Blow type fuse must be used per one module. Also, in-rush surge current flows during line throw-in. Be sure to check I²t rating of external switch and external fuse.

Recommended External Fuse: 15A

Select fuse based on rated voltage, rated current and surge current capability.

(1) Voltage Ratings

100VAC line: AC125V

200VAC line: AC250V

(2) Current Ratings

Rated current is determined by the maximum input current based on operating conditions and can be calculated by the following formula.

$$I_{in(max)} = \frac{P_{out}}{V_{in} \times \text{Eff} \times \text{PF}} \quad (\text{Arms}) \quad (\text{Formula 1-1})$$

I_{in} (max): Maximum Input Current

P_{out}: Maximum Output Power

V_{in}: Minimum Input Voltage

Eff: Efficiency

PF: Power Factor

For efficiency and power factor values, refer to separate "Evaluation Data of each product".

C1, C4, C5: 1uF (Film Capacitor)

Ripple current flows through this capacitor. When selecting capacitor, be sure to check the allowable maximum ripple current rating of this capacitor. Verify the actual ripple current flowing through this capacitor by doing actual measurement.

Recommended Voltage Rating: 250VAC

Note) Connect C5 as near as possible towards the input terminals of this power module.

L1, L2: 6mH

Add common mode choke coil as EMI/EMS counter-measure. When using multiple modules, connect coil to each module.

Note) Depending on the input filter used, noise might increase or power module might malfunction due to filter resonance.

C2, C3: 4,700pF (Ceramic Capacitor)

Add ceramic capacitor as EMI/EMS countermeasure. Be sure to consider leakage current of your equipment when adding this capacitor.

High withstand voltage are applied across this capacitor depending on the application. Select capacitors with high withstand voltage rating.

R1: 470kΩ

Connect bleeder resistor across AC(L) and AC(N) terminals.

C6, C7: 1000pF (Ceramic Capacitor)

Add ceramic capacitor as EMI/EMS countermeasure. Be sure to consider leakage current of your equipment when adding this capacitor.

High withstand voltage are applied across this capacitor during withstand voltage test depending on the application. Select capacitors with high withstand voltage rating.

Also, connect C6, C7 as close as possible to the terminals.

C8, C9: 1uF (Film Capacitor)

Ripple current flows through this capacitor. When selecting capacitor, be sure to check the allowable maximum ripple current rating of this capacitor. Verify the actual ripple current flowing through this capacitor by doing actual measurement.

Recommended Voltage Rating : 450VDC

Note) Select Capacitor with more than 3A (rms) rating. Connect C8, C9 as near as possible towards the output terminals of this power module.

C10: Electrolytic Capacitor

PFE300S: 470μF × 1

PFE500S: 390μF × 2 pcs in parallel

Refer to "Selection Method of External Bulk Capacitor for Boost Voltage" below.

Allowable External Capacitance at nominal capacitor value is shown below.

Recommended Voltage Rating: 450VDC

Recommended Total Capacitor: 390uF to 1,200uF

Note) 1. Do not connect capacitors with more than the above capacitance value as this would result into power module damage.

2. When using module below -20°C ambient temperature, AC ripple of boost voltage, output ripple voltage and stand up characteristics might be affected by ESR characteristics of the bulk capacitor.

Therefore, be sure to verify characteristics by actual evaluation.

C11: 1000pF (Ceramic Capacitor)

Add ceramic capacitor as EMI/EMS countermeasure.

High withstand voltage are applied across this capacitor during withstand voltage test depending on the application. Select capacitors with high withstand voltage rating.

Also, connect C11 as close as possible to the terminals.

C12, C13: 0.033uF

Connect ceramic or film capacitor as EMI/EMS counter-measure and to reduce spike noise.

Note) High Voltage is applied across this capacitor during withstand voltage test depending on the application.

Connect C12, C13 as near as possible towards the output terminals of this power module.

C14: Refer to Table 1-1

To reduce output ripple noise voltage, connect electrolytic capacitors across +V and -V.

Note) Connect C14 as near as possible to the +V and -V output terminals of this power module.

Vout	C14
12V	25V 1,000uF
28V	50V 470uF
48V	100V 220uF

Table 1-1 C14 : Recommended external capacitance

C15: 2.2uF

Connect chip ceramic capacitor within 50mm from the output terminals +V and -V of the power module to reduce output spike noise.

Also, note that output spike voltage may vary depending on the wiring pattern of the printed circuit board.

C16 : Refer to Table 1-2

Connect C16 within 50mm from the output terminals +V and -V of the power module to stabilize operation.

Note that the output ripple and line turn off characteristics of the power module might be affected by the ESR and ESL of the electrolytic capacitor.

Also, note that output ripple voltage may vary depending on the wiring pattern of the printed circuit board.

Sudden change in output voltage due to sudden load change or sudden input voltage change can be reduced by increasing external output capacitor value.

Vout	C16
12V	25V 1,000uF
28V	50V 470uF
48V	100V 220uF

Table 1-2 C16 : Recommended external capacitance

- Note) 1. Use low-impedance electrolytic capacitors with excellent temperature characteristics.
(Nihon Chemi-con LXY Series or equivalent)
(Nichicon PM Series or equivalent)
2. For module operation at ambient temperature -20°C or less, output ripple voltage might be affected by ESR characteristics of the electrolytic capacitors. Increase the capacitor values shown in Table 1-1 and 1-2 according to the table below.

Vout	C14, C16
12V	25V 1,000uF x 2parallel
28V	50V 470uF x 2parallel
48V	100V 220uF x 2parallel

Table 1-3 C14, C16 : Recommended external capacitance

(Ambient Temperature < -20 deg C)

3. Take note of the maximum allowable ripple current of the electrolytic capacitor used. Especially, for sudden

load current changes, verify actual ripple current and make sure that allowable maximum ripple current is not be exceeded.

● **Selection Method of External Bulk Capacitor for Boost Voltage**

Boost voltage bulk capacitor is determined by boost voltage ripple voltage, ripple current and hold-up time.

Select capacitor value such that boost voltage ripple voltage does not exceed 15Vp-p.

Note) When ambient temperature is -20°C or less,

Boost voltage might increase due to ESR characteristics. Therefore, verify above characteristics by actual evaluation.

For output hold-up time, refer to separate document "PFE 300S Series Evaluation Data" or "PFE500S Series Evaluation Data" and use appropriate capacitor up to 1,200uF maximum. (It is recommended that verification should be done through actual evaluation).

For allowable ripple current value, refer to Fig. 1-2 and select a capacitor with higher ripple current rating.

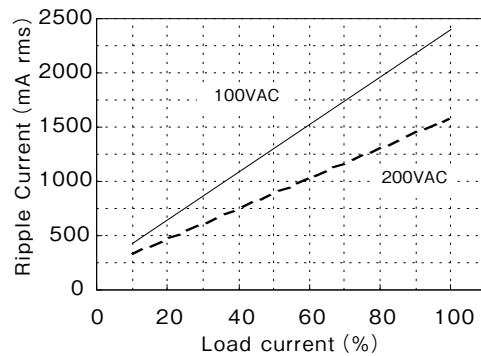

Fig. 1-2 Allowable ripple current value

TFR1 : 10 to 100Ω

By connecting thermal fuse resistor across R and +BC terminals as shown in Fig.1-1, in-rush current during line throw-in can be suppressed. Failures due to in-rush current such as melting of external fuse, welding of relay or switch connecting joints or shutdown of No-Fuse Breakers (NFB) can occur. Therefore, be sure to connect this external thermal fuse resistor.

Note that this module will not operate without this external resistor.

● **Selection Method of External Resistor**

- (1) Calculating Resistance Value for TFR1

Resistance can be calculated by the formula below.

$$R = \frac{V_{in}}{I_{rush}} \text{ (}\Omega\text{)} \text{ (Formula 1-2)}$$

R: Resistance Value for External TFR1

V_{in}: Input Voltage converted to DC value
=Input Voltage (rms) × √2

I_{rush}: Input surge current value

- (2) Required Surge Current Rating

Sufficient surge current withstand capability is required for external TFR1.

Required Surge Current Rating can be selected by I²t. (Current squared multiplied by time).

$$I^2t = \frac{C_o \times V_{in}^2}{2 \times R} (A^2s) \text{ (Formula 1-3)}$$

- I²t: Current-squared multiplied by time
- C_o: Booster Voltage Bulk Capacitance
- V_{in}: Input Voltage converted to DC value
= Input Voltage (rms) × √2
- R: Resistance Value for External TFR1

2 Output Voltage Adjustment Range

Output Voltage can be adjusted within the range below by connecting fixed and variable resistors. However, take care not to exceed the output voltage range shown below because OVP function will activate.

Output Voltage Adjustment Range :
±20% of the typical voltage rating

When increasing output voltage, reduce output current so as not to exceed maximum output power.

Even if the output voltage is adjusted using external circuit shown in Fig.2-1, remote sensing can be done. For details on remote sensing function, refer to "9. Remote Sensing".

Output Voltage Adjustment using Fixed and Variable Resistors

External resistor (R1) and variable resistor (VR) values, as well as, circuit connection is shown below.

For this case, remote programming of the output voltage can be done through the remote programming resistor VR. Be sure to connect the remote programming resistor between +S and +V terminals.

	12V	28V	48V
R1	10k	47k	100k
VR	10k	20k	30k

unit: [Ω]

- External Resistor: Tolerance ±5% or less
- Variable Resistor: Total Tolerance ±20% or less
End Resistance 1% or less

Table 2-1 External Resistor and Variable Resistor Value (For ±20% Output Adjustment)

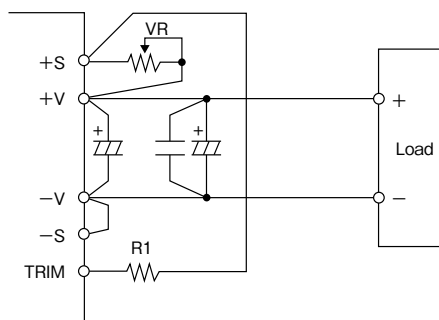

Fig. 2-1 External Resistor Connection Example

3 Maximum Ripple and Noise

This value is measured according to the description below in accordance with JEITA-9131A (Section 7.1.2 and Section 7.1.3).

In the basic connection shown in Fig.1-1, additional connection shown in Fig.3-1 is done for measurement. Capacitor (Ceramic Capacitor: 2.2 μF and Electrolytic

Capacitor: Refer to Table 1-2) must be connected within 50mm from the output terminals. Then, connect coaxial cable with JEITA attachment across the ceramic capacitor electrodes. Use 100MHz bandwidth oscilloscope or equivalent.

Also, note that output ripple voltage and output spike noise may vary depending on the wiring pattern of the printed circuit board.

In general, output ripple voltage and output spike noise can be reduced by increasing external capacitor value.

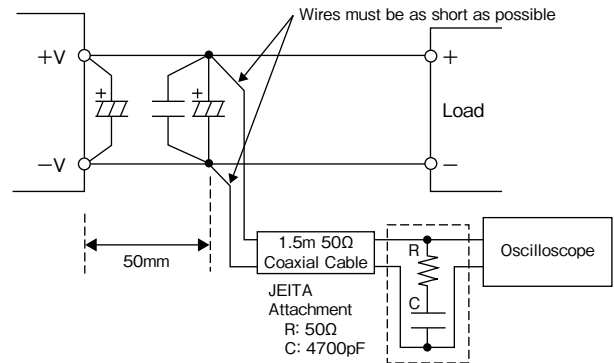

Fig. 3-1 Output Ripple Voltage (including Spike Noise) Measurement Method

4 Maximum Line Regulation

Maximum line regulation is defined as the maximum output voltage change when input voltage is gradually changed (Steady-State) within specification range.

5 Maximum Load Regulation

Maximum load regulation is defined as the maximum output voltage change when output load current is gradually changed (Steady-State) within specification range.

When using power module in dynamic load mode, audible sound could be heard from the power module or large output voltage change can occur. Make prior evaluation thoroughly before using this power module.

6 Over Current Protection (OCP)

This module is equipped with OCP function. Output will automatically recover when short circuit or overload condition is removed. OCP value is fixed and cannot be adjusted externally.

Note that continuous short circuit or overload condition might result in power module damage.

7 Over Voltage Protection (OVP)

This module is equipped with OVP function. This value is set between 125% to 145% of nominal output voltage.

When the OVP function activates, first cut off input line and verify that boost voltage has dropped down to 20V or less. Then, recover output by recycling input line.

OVP value is fixed and cannot be set externally.

8 Over Temperature Protection (OTP)

This module is equipped with OTP function. This function will activate and shutdown the output when ambient temperature or internal temperature abnormally rises. OTP activates at following baseplate temperature.

PFE300S-12, 28, 48:	105 to 130°C
PFE500S-12:	90 to 115°C
PFE500S-28, 48:	105 to 130°C

When OTP function operates, output can be recovered by cooling down the baseplate sufficiently and letting the boost voltage drop down to 20V or less before recycling the input line.

9 Remote Sensing (+S, -S Terminals)

This module has remote sensing terminals to compensate for voltage line drop from the output terminals to the output load. When remote sensing is not required (local sensing) short +S to +V and -S to -V terminals respectively.

Note that line drop (voltage drop due to wiring) compensation voltage range must be such that the output voltage is within the output voltage adjustment range and that the voltage between -V and -S must be within 2V.

Consider power loss due to line drop and use power module within the maximum allowable output power. Reduce the effect of noise to the remote sensing line by using a shield line, a twist pair, or a parallel pattern, etc.

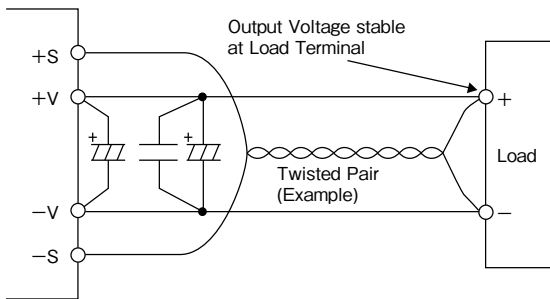

Fig. 9-1 Remote Sensing is used

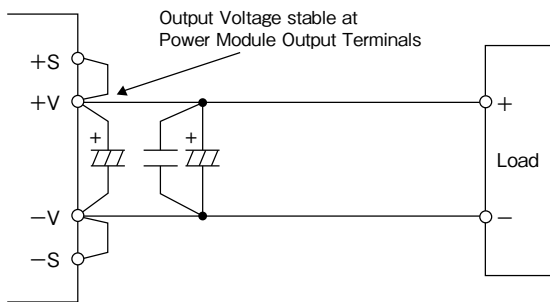

Fig. 9-2 Remote Sensing is not used (Local Sensing)

10 Series Operation

Series operation is possible for PFE300S, 500S Series. Connections shown in Fig.10-1 and Fig.10-2 are possible.

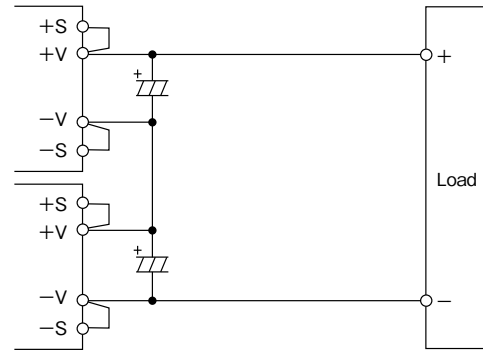

Fig. 10-1 Series Operation for High Output Voltage Applications

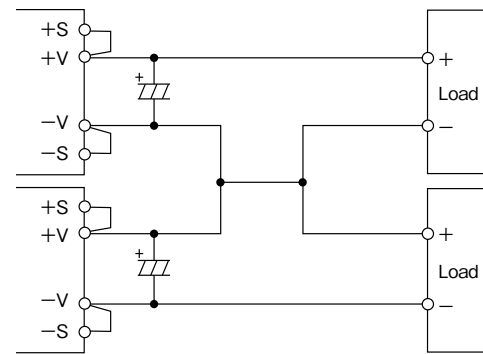

Fig. 10-2 ±Output Series Applications

11 Power ON Signal (ENA Terminal)

This signal is located at the secondary side (output side) and is an open collector output.

(Maximum sink current is 10mA and maximum applied voltage is 75V.)

Return line for ENA terminal is the -V terminal.

When output voltage goes over a specified voltage level at start up, Power ON signal is "Low level".

Output voltage threshold level is as follows.

PFE300S or PFE500-12 :	9V (TYP)
PFE300S or PFE500-28 :	21V (TYP)
PFE300S or PFE500-48 :	37V (TYP)

On the other hand, output voltage threshold level for Power ON signal to turn high level at shutdown varies according to output condition. Therefore, be sure to do actual verification.

12 Operating Ambient Temperature Range

These products can be used in any orientation but be sure to consider enough airflow to avoid heat accumulation around the module. Consider surrounding components layout and set the PCB mounting direction such that air can flow through the heatsink by forced or convection cooling.

This product can operate at actual mounting condition when baseplate temperature is maintained at or below the following baseplate temperature:

PFE300S-12, 28, 48:	100°C
PFE500S-12:	85°C
PFE500S-28, 48:	100°C

Verify baseplate temperature at worst case operating condition at the measuring point shown in Fig. 12-1.

For Thermal Design details, refer to Application Notes "Thermal Design" section.

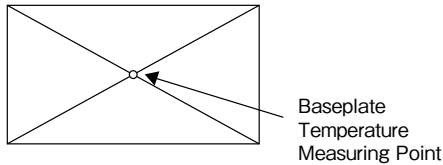

Fig. 12-1 Baseplate Measuring Point

Baseplate temperature range is limited according to Fig. 12-2.

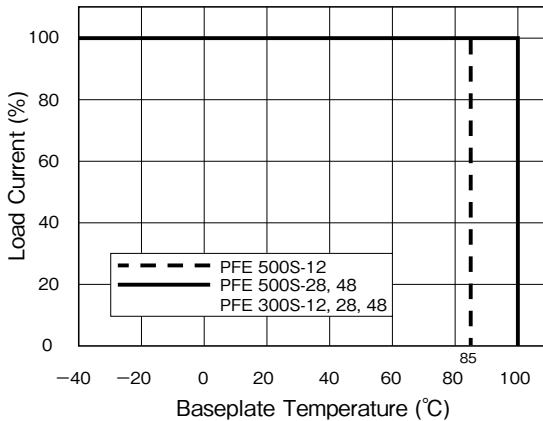

Fig. 12-2 Derating Curve

To further improve the reliability, it is recommended to use this module with baseplate temperature derating.

13 Operating Ambient Humidity

Note that dewdrop might cause power module abnormal operation or damage.

14 Storage Ambient Temperature

Note that rapid temperature change causes dewdrop, causing harmful effect on soldering condition of the terminal pins.

15 Storage Ambient Humidity

Storage under high temperature and high humidity causes rust on terminal pins that causes deterioration of soldering conditions. Take enough caution when storing this module.

16 Cooling Method

For details of thermal design, refer to Application Notes "Thermal Design" section.

17 Withstand Voltage

This module is designed to withstand applied voltage 2.5kVAC between input and baseplate, 3kVAC between

input and output for a duration of 1 minute. When doing this test during incoming inspection, set the current limit of test equipment to 20mA.

This module is designed to withstand applied voltage 1.5kVDC between output and baseplate for 1 minute. When doing this test during incoming inspection, be sure to apply DC voltage only. Avoid applying AC voltage during this test because this will damage the module.

Refrain from injecting high test voltage suddenly. Be sure to gradually increase the applied withstand voltage during testing and gradually reduce the voltage after the test.

Especially, when using timer switch of the test equipment, impulse voltage which is higher than the applied set voltage, is generated when the timer switch is cut off. This causes damage to the power module. Connect each terminal according to the circuit diagram shown below.

For basic connection shown in Fig.1-1, do the same terminal connections.

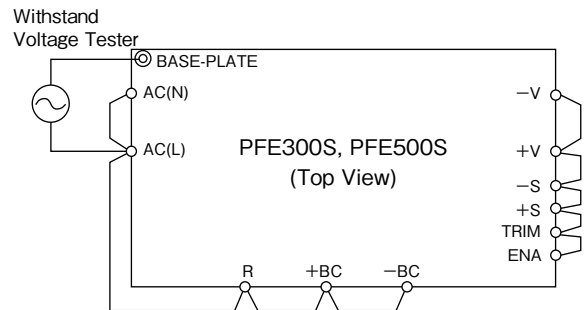

2.5kVAC 1 minute (20mA)

Fig. 17-1 Input to Baseplate Withstand Voltage Test Method

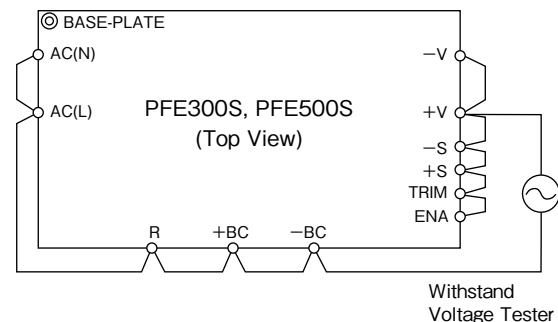

3kVAC 1 minute (20mA)

Fig.17-2 Input to Output Withstand Voltage Test Method

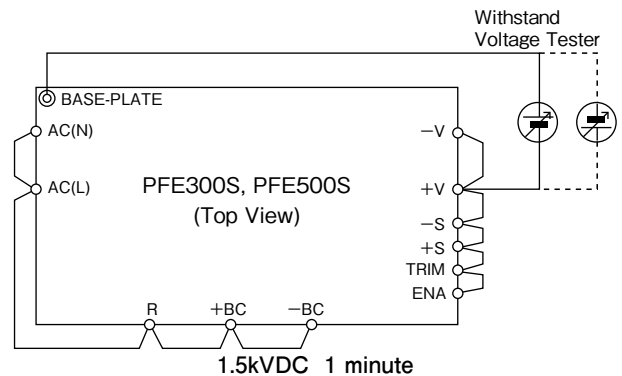

1.5kVDC 1 minute

Fig.17-3 Output to Baseplate Withstand Voltage Test Method

18 Insulation Resistance

Use DC Insulation Resistance test equipment (MAX.500V) between output and baseplate. Insulation Resistance must be 100MΩ or more at 500VDC. Take caution that some types of test equipment generate high pulse voltage when switching applied voltage. After test, discharge this module using resistor, etc.

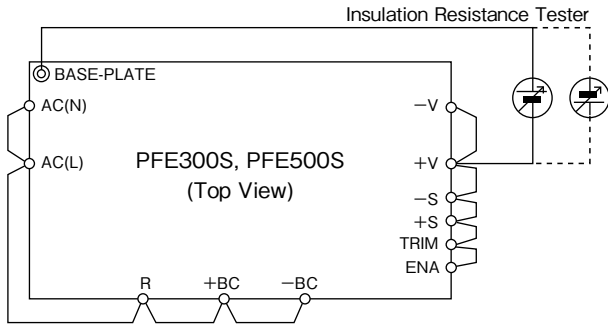

100MΩ or more at 500VDC
Fig. 18-1 Insulation Resistance Test Method

19 Recommended Soldering Condition

Recommended soldering temperature is as follows.
 (1) Soldering Dip : 260°C, within 10 seconds
 Preheat : 130°C, within 60 seconds
 (2) Soldering iron : 350°C, within 3 seconds

3. Before Concluding Power Module Damage

Verify following items before concluding power module damage.

- 1) No output voltage
 - Is specified input voltage applied?
 - During output voltage adjustment, is the fixed resistor or variable resistor setting correct?
 - Is there no abnormality with the output load?
 - Is the actual baseplate temperature within the specified operating temperature of this module?
- 2) Output voltage is high
 - Are the remote sensing terminals (+S, -S) correctly connected?
 - Is the measurement done at the sensing points?
 - During output voltage adjustment, is the fixed resistor or variable resistor setting correct?
- 3) Output voltage is low
 - Is specified input voltage applied?
 - Are the remote sensing terminals (+S, -S) correctly connected?
 - Is the measurement done at the sensing points?
 - During output voltage adjustment, is the fixed resistor or variable resistor setting correct?
 - Is there no abnormality with the output load?
- 4) Load regulation or line regulation is large
 - Is specified input voltage applied?
 - Are the input or output terminals firmly connected?
 - Is the measurement done at the sensing points?
 - Are the input and output wires too thin?
- 5) Large output ripple
 - Is the measurement done according to methods described Application Notes or is it an equivalent method?

PFE700S Instruction Manual

BEFORE USING THE POWER SUPPLY UNIT

Be sure to read this instruction manual thoroughly before using this product. Pay attention to all cautions and warnings before using this product. Incorrect usage could lead to an electric shock, damage to the unit or a fire hazard.

WARNING

- Do not make unauthorized changes to power supply unit, otherwise you may have electric shock and void your warranty.
- Do not touch this unit and the internal components in operation or shortly after shut down. They may have high voltage or high temperature and as the unit dissipates its heat so the surface of the unit is hot. You may receive electric shock or burn.
- When the unit is operating, keep your hands and face away from it; you may be injured by an accident.
- Do not use unit under unusual condition such as emission of smoke or abnormal smell and sound etc. It might cause fire and electric shock. In such case, please contact us; do not repair by yourself, as it is dangerous for the user.
- Do not drop or insert anything into unit. It might cause failure and fire.
- Do not operate these units under condensation condition. It may cause fire and electric shock.

CAUTION

- As a component part, compliance with the standard will be based upon installation in the final application. This product must be installed in a restricted access location, accessible to authorized competent personnel only. These AC to DC converters have reinforced insulation between the input and the output. The outputs of these products are energy hazards. This model is considered to be non-SELV. As such, the instructions for use must refer to these energy hazardous outputs and Non-SELV outputs in that the outputs must not be accessible to the operator. The installer must also provide protection against inadvertent contact by a service engineer.
- The equipment has been evaluated for use in a Pollution Degree 2 environment.
- This power supply is primarily designed and manufactured to be used and enclosed in other equipment.
- Confirm connections to input/output terminals and signal terminals are correct as indicated in the instruction manual.
- Attach an HBC external fuse to each module to ensure safety operation and compliance to each safety standard approval. The recommended input fuse rating within the instructions is as follows: -15AHBC, 250V fast acting fuse. The breaking capacity and voltage rating of this fuse may be subject to the end use application.

- Input voltage, output current, output power, ambient temperature and ambient humidity should be used within specifications, otherwise the unit will be damaged.
- For application equipment, which requires very high reliability (nuclear related equipment, traffic control equipment, medical equipment, etc.), please provide fail safety function in the equipment.
- Do not use the product in environment with strong electromagnetic field, corrosive gas and conductive substance.
- Do not operate and store this unit at an environment where condensation occurs. In such case, waterproof treatment is necessary.
- Never operate the unit under over current or shorted conditions for 30 seconds or more and out of input voltage range as specification. Insulation failure, smoking, burning or other damage may occur to the unit.
- The output voltage of this power supply unit is considered to be a hazardous energy level. (The voltage is 2V or more and the electric power is 240VA or more.) Prevention from direct contact with output terminal is highly necessary. While installing or servicing this power supply unit, avoid dropping tools by mistake or direct contact with output terminal. This might cause an electric shock. While repairing this power supply unit, the AC input power must be switched off and the input and output voltage should be level.
- To maintain the SELV output for outputs less than 28VDC, under fault conditions, the output must be connected to earth in the final application.
- The application circuits and their parameter are for reference only. Be sure to verify effectiveness of application circuits and their parameters before finalizing circuit design.
- Do not inject abnormal voltage to output terminal and signal terminal from the outside. The injection of reverse voltage or over voltage exceeding nominal output voltage to output terminals might cause damage to internal components.
- This information in this document is subject to change without prior notice. For actual design-in, please refer to the latest publications of data sheet, etc., for the most up-to-date specifications of the unit.
- No part of this document may be copied or reproduced in any form without prior written consent of TDK-Lambda.

Note : CE MARKING

CE Marking when applied to a product covered by this handbook indicates compliance with the low voltage directive (2006/95/EC) in that it complies with EN60950-1.

1. Terminal Explanation

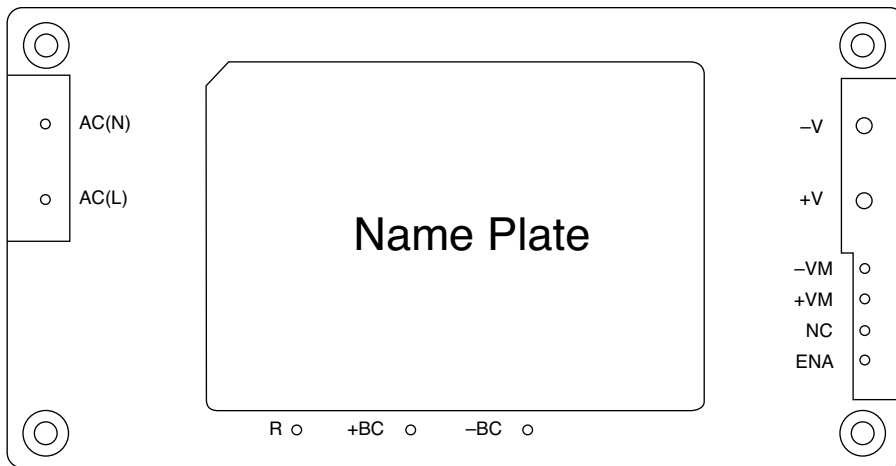

[Input side terminals]

- AC (L): Input terminal live line
- AC (N): Input terminal neutral line
- +BC : +Boost voltage terminal
- BC : -Boost voltage terminal
- R : External inrush current limiting resistor

[Output side terminals]

- +V : +Output terminal
- V : -Output terminal
- +VM : +VOutput monitor terminal
- VM : -VOutput monitor terminal
- NC : Make no external connection
- ENA : Power on signal terminal

- Baseplate can be connected to FG through M3 mounting tapped holes.
- Consider contact resistance when connecting AC(L), AC(N), R, +BC, -BC, +V, -V.
- Note that +BC and -BC terminals are primary voltage with high voltage (385VDC). Do not connect load from these terminals.
- Do not make external connection to NC terminal.

2. Explanations on Specifications

This manual explains based on "Fig. 1-1 Basic Connection." Please do actual evaluation when changing circuit from Fig.1-1.

1 Input Voltage Range

Input voltage range is indicated below. Take care not to apply input voltage which is out of this specified range nor should a DC input voltage be applied as this would result into power module damage.

Input Voltage Range: Single Phase 85 to 265VAC
Line Frequency Range : 47 to 63Hz

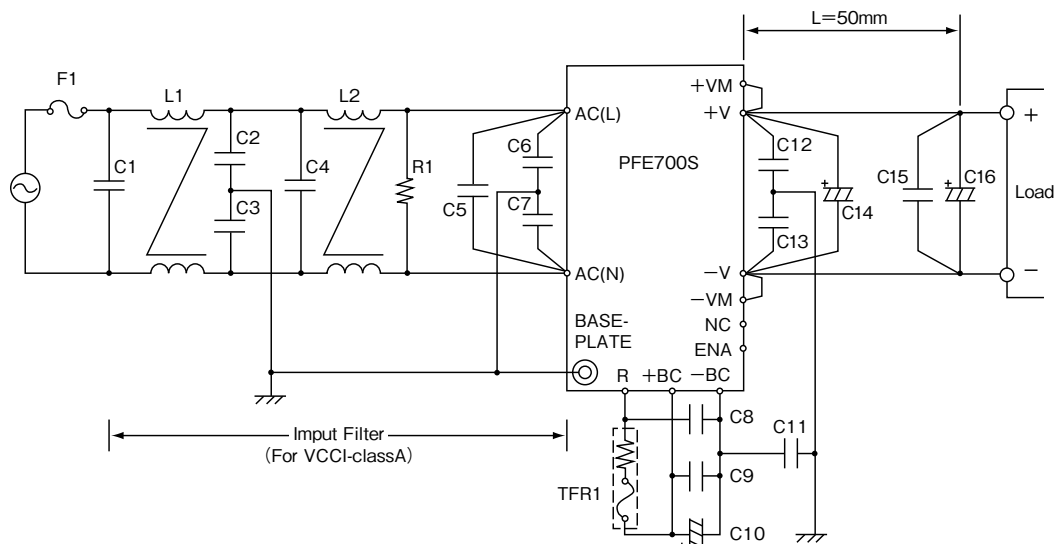

Fig. 1-1 Basic Connection

F1: External Input Fuse

This power module has no internal fuse. Use external fuse to acquire each safety standard and to further improve safety. Further, Fast-Blow type fuse must be used per one module. Also, in-rush surge current flows during line throw-in. Be sure to check I²t rating of external switch and external fuse.

Recommended External Fuse: 15A

Select fuse based on rated voltage, rated current and surge current capability.

(1) Voltage Ratings

100VAC line: AC125V

200VAC line: AC250V

(2) Current Ratings

Rated current is determined by the maximum input current based on operating conditions and can be calculated by the following formula.

$$I_{in(max)} = \frac{P_{out}}{V_{in} \times \text{Eff} \times \text{PF}} \text{ (Arms) (Formula 1-1)}$$

$I_{in(max)}$: Maximum Input Current

P_{out} : Maximum Output Power

V_{in} : Minimum Input Voltage

Eff: Efficiency

PF: Power Factor

For efficiency and power factor values, refer to separate document "PFE700S Series Evaluation Data".

C1, C4, C5: 1 μF (Film Capacitor)

Ripple current flows through this capacitor. When selecting capacitor, be sure to check the allowable maximum ripple current rating of this capacitor. Verify the actual ripple current flowing through this capacitor by doing actual measurement.

Recommended Voltage Rating: 250VAC

Note) Connect C5 as near as possible towards the input terminals of this power module.

L1, L2: 6mH

Add common mode choke coil as EMI/EMS counter-measure. When using multiple modules, connect coil to each module.

Note) Depending on the input filter used, noise might increase or power module might malfunction due to filter resonance.

C2, C3: 4,700pF (Ceramic Capacitor)

Add ceramic capacitor as EMI/EMS countermeasure. Be sure to consider leakage current of your equipment when adding this capacitor.

High withstand voltage are applied across this capacitor depending on the application. Select capacitors with high withstand voltage rating.

R1: 470kΩ

Connect bleeder resistor across AC(L) and AC(N) terminals.

C6, C7: 1000pF (Ceramic Capacitor)

Add ceramic capacitor as EMI/EMS countermeasure. Be sure to consider leakage current of your equipment when adding this capacitor.

High withstand voltage are applied across this capacitor during withstand voltage test depending on the application. Select capacitors with high withstand voltage rating.

Also, connect C6, C7 as close as possible to the terminals.

C8, C9: 1μF (Film Capacitor)

Ripple current flows through this capacitor. When selecting capacitor, be sure to check the allowable maximum ripple current rating of this capacitor. Verify the actual ripple current flowing through this capacitor by doing actual measurement.

Recommended Voltage Rating: 450VDC

Note) Select Capacitor with more than 3A (rms) rating. Connect C8, C9 as near as possible towards the output terminals of this power module.

C10: 780μF (390 μF × 2 pcs. in parallel) (Electrolytic Capacitor)

Refer to "Selection Method of External Bulk Capacitor for Boost Voltage" below.

Allowable external capacitance at nominal capacitor value is shown below.

Recommended Voltage Rating: 450VDC**Recommended Total Capacitor: 390uF to 1,200uF**

Note) 1. Do not connect capacitors with more than the above capacitance value as this would result into power module damage.
2. When using module below -20 deg C ambient temperature, AC ripple of boost voltage, output ripple voltage and start up characteristics might be affected by ESR characteristics of the bulk capacitors. Therefore, be sure to verify characteristics by actual evaluation.

C11: 1000pF (Ceramic Capacitor)

Add ceramic capacitor as EMI/EMS countermeasure.

High withstand voltage are applied across this capacitor during withstand voltage test depending on the application. Select capacitors with high withstand voltage rating.

Also, connect C11 as close as possible to the terminals.

C12, C13: 0.033 μF

Connect ceramic or film capacitor as EMI/EMS countermeasure and to reduce spike noise.

Note) High voltage is applied across this capacitor during withstand voltage test depending on the application.

Connect C12, C13 as near as possible towards the output terminals of this power module.

C14: 220 μF

To reduce output ripple noise voltage, connect electrolytic capacitors across +V and -V.

Note) Connect C14 as near as possible to the +V and -V output terminals of this power module.

Recommended Voltage Rating: 100VDC

C15: 2.2 μF

Connect chip ceramic capacitor within 50mm from the output terminals +V and -V of the power module to reduce output spike noise.

Also, note that output spike voltage may vary depending on the wiring pattern of the printed circuit board.

C16: 220 μF

Connect C13 within 50mm from the output terminals +V and -V of the power module to stabilize operation.

Note that the output ripple and line turn off characteristics of the power module might be affected by the ESR and ESL of the electrolytic capacitor.

Also, note that output ripple voltage may vary depending on the wiring pattern of the printed circuit board.

Sudden change in output voltage due to sudden load change or sudden input voltage change can be reduced by increasing external output capacitor value.

Recommended Voltage Rating: 100VDC

- Note) 1. Use low-impedance electrolytic capacitors with excellent temperature characteristics.
(Nichicon PM Series or equivalent)
2. For module operation at ambient temperature -20 deg C or less, output ripple voltage might be affected by ESR characteristics of the electrolytic capacitors. Increase the capacitor values shown below.

C14, C16: 100V 220μF x 2 parallel
(Ambient Temperature < -20 deg C)

3. Take note of the maximum allowable ripple current of the electrolytic capacitor used. Especially, for sudden load current changes, verify actual ripple current and make sure that allowable maximum ripple current is not be exceeded.

● Selection Method of External Bulk Capacitor for Boost Voltage

Boost voltage bulk capacitor is determined by boost voltage ripple voltage, ripple current and hold-up time.

Select capacitor value such that boost voltage ripple voltage does not exceed 15Vp-p.

Note) When ambient temperature is -20 deg C or less, Boost voltage might increase due to ESR characteristics. Therefore, verify above characteristics by actual evaluation.

For output hold-up time, refer to separate document "PFE700S Series Evaluation Data" and use appropriate capacitor up to 1,200uF maximum. (It is recommended that verification should be done through actual evaluation).

For allowable ripple current value, refer to Fig.1-2 and select a capacitor with higher ripple current rating.

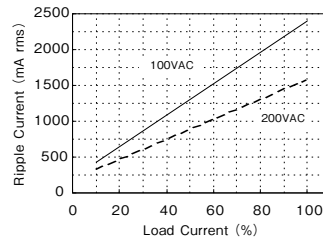

Fig. 1-2 Allowable ripple current value

TFR1: 10 to 100 ohm

By connecting thermal fuse resistor across R and +BC terminals as shown in Fig.1-1, in-rush current during line throw-in can be suppressed. Failures due to in-rush current such as melting of external fuse, welding of relay or switch connecting joints or shutdown of No-Fuse Breakers (NFB) might occur. Therefore, be sure to connect this external thermal fuse resistor.

Note that this module will not operate without this external resistor.

● Selection Method of External Resistor

- (1) Calculating Resistance Value for TFR1

Resistance can be calculated by the formula below.

$$R = \frac{V_{in}}{I_{rush}} (\Omega) \text{ (Formula 1-2)}$$

R : Resistance Value for External TFR1

V_{in} : Input Voltage converted to DC value
= Input Voltage (rms) × √2

I_{rush} : Input surge current value

- (2) Required Surge Current Rating

Sufficient surge current withstand capability is required for external TFR1. Required surge current rating can be selected by I²t. (Current squared multiplied by time)

$$I^2t = \frac{C_o \times V_{in}^2}{2 \times R} (A^2s) \text{ (Formula 1-3)}$$

I²t : Current-squared multiplied by time

C_o : Boost Voltage Bulk Capacitance

V_{in} : Input Voltage converted to DC value
= Input Voltage (rms) × √2

R : Resistance Value for External TFR1

2 Maximum Ripple and Noise

This value is measured according to the description below in accordance with JEITA-9131A (Section 7.12 and Section 7.13).

In the basic connection shown in Fig.1-1, additional connection shown in Fig.2-1 is done for measurement. Capacitor (ceramic capacitor 2.2μF and electrolytic capacitor: 220μF) must be connected within 50mm from the output terminals. Then, connect coaxial cable with JEITA attachment across the ceramic capacitor electrodes. Use 100MHz bandwidth oscilloscope or equivalent.

Also, note that output ripple voltage and output spike noise may vary depending on the wiring pattern of the printed circuit board.

In general, output ripple voltage and output spike noise can be reduced by increasing external capacitor value.

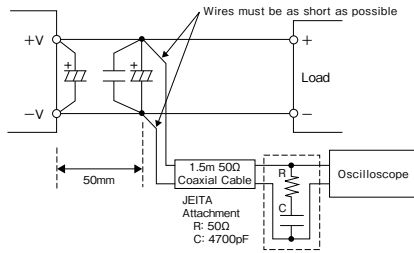

Fig. 2-1 Output Ripple Voltage (including Spike Noise) Measurement Method

3 Maximum Line Regulation

Maximum line regulation is defined as the maximum output voltage change when input voltage is gradually changed (steady-state) within specification range.

4 Maximum Load Regulation

Maximum load regulation is defined as the maximum output voltage change when output load current is gradually changed (steady-state) within specification range.

When using power module in dynamic load mode, audible sound could be heard from the power module or large output voltage change can occur. Make prior evaluation thoroughly before using this power module.

5 Over Current Protection (OCP)

This module is equipped with OCP function. Output will automatically recover when short circuit or overload condition is removed. OCP value is fixed and cannot be adjusted externally. Note that continuous short circuit or overload condition might result in power module damage.

6 Over Voltage Protection (OVP)

This module is equipped with OVP function. This value is set between 60.0V to 69.6V. When the OVP function activates, first cut off input line and verify that boost voltage has dropped down to 20V or less. Then, recover output by recycling input line. OVP value is fixed and cannot be set externally.

7 Over Temperature Protection (OTP)

This module is equipped with OTP function. This function will activate and shut down the output when ambient temperature or internal temperature abnormally rises. OTP activates at following baseplate temperature.

OTP operating temperature: 105 to 130 deg C

When OTP function operates, output can be recovered by cooling down the baseplate sufficiently and letting the boost voltage drop down to 20V or less before recycling the input line.

8 Parallel Operation

Current share parallel operation is possible for PFE700S Series by connecting the output terminal of each power module. Verify the allowable maximum total output current by actual evaluation such that maximum output current rating of each module is not exceeded. Consult us for details when using PFE700S Series at parallel operation.

9 Series Operation

Series operation is possible for PFE700S Series. Connections shown in Fig.9-1 and Fig.9-2 are possible.

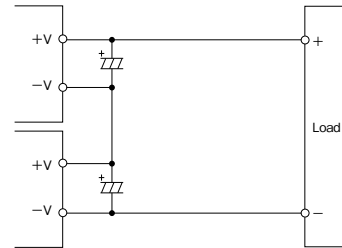

Fig. 9-1 Series Operation for High Output Voltage Applications

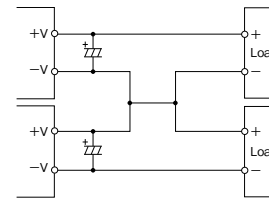

Fig. 9-2 +/- Output Series Applications

10 Power ON Signal (ENA Terminal)

This signal is located at the secondary side (output side) and is an open collector output. (Maximum sink current is 10mA and maximum applied voltage is 75V.) When output voltage goes over 46V(TYP) at start up, Power ON signal is "Low Level". On the other hand, output voltage threshold level for Power ON signal to turn "High Level" at shutdown varies according to output condition. Therefore, be sure to do actual verification.

11 Operating Ambient Temperature Range

These products can be used in any orientation but be sure to consider enough airflow to avoid heat accumulation around the module. Consider surrounding components layout and set the PCB mounting direction such that air can flow through the heatsink by forced or convection cooling. This product can operate at actual mounting condition when baseplate temperature is maintained at or below the 100 deg C. Verify baseplate temperature at worst case operating condition at the measuring point shown in Fig.11-1. For Thermal Design details, refer to Application Notes "Thermal Design" section.

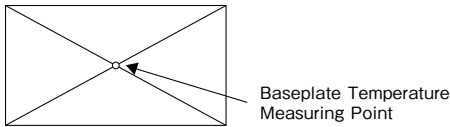

Fig.11-1 Baseplate Measuring Point

Baseplate temperature range is limited according to Fig. 11-2.

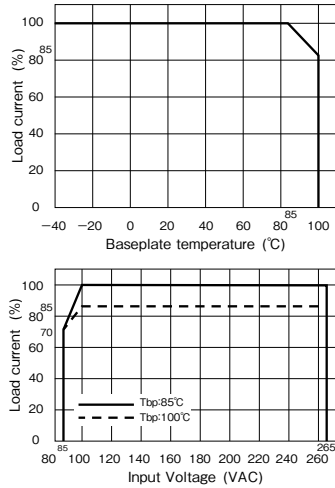

Fig. 11-2 Derating Curve

To further improve the reliability, it is recommended to use this module with baseplate temperature derating.

12 Operating Ambient Humidity

Note that dewdrop might cause power module abnormal operation or damage.

13 Storage Ambient Temperature

Note that rapid temperature change causes dewdrop causing harmful effect on soldering condition of the terminal pins.

14 Storage Ambient Humidity

Storage under high temperature and high humidity causes rust on terminal pins that causes deterioration of soldering conditions. Take enough caution when storing this module.

15 Cooling Method

For details of thermal design, refer to Application Notes "Thermal Design" section.

16 Withstand Voltage

This module is designed to withstand applied voltage 2.5kVAC between input and baseplate, 3kVAC between input and output for a duration of 1 minute. When doing this test during incoming inspection, set the current limit of test equipment to 20mA.

This module is designed to withstand applied voltage 1.5kVDC between output and baseplate for 1 minute. When doing this test during incoming inspection, be sure

to apply DC voltage only. Avoid applying AC voltage during this test because this will damage the module. Refrain from injecting high test voltage suddenly. Be sure to gradually increase the applied withstand voltage during testing and gradually reduce the voltage after the test. Especially, when using timer switch of the test equipment, impulse voltage which is higher than the applied set voltage, is generated when the timer switch is cut off. This causes damage to the power module. Connect each terminal according to the circuit diagram shown below. For basic connection shown in Fig.1-1, do the same terminal connections.

Withstand Voltage Tester

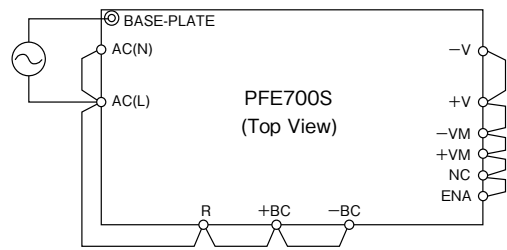

2.5kVAC 1 minute (20mA)

Fig. 16-1 Input to Baseplate Withstand Voltage Test Method

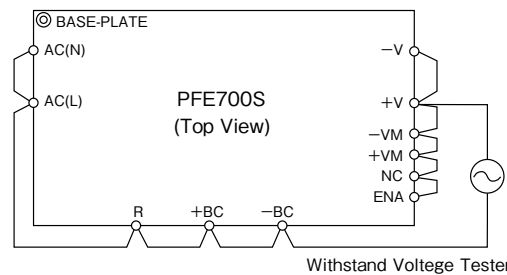

3kVAC 1 minute (20mA)

Fig.16-2 Input to Output Withstand Voltage Test Method

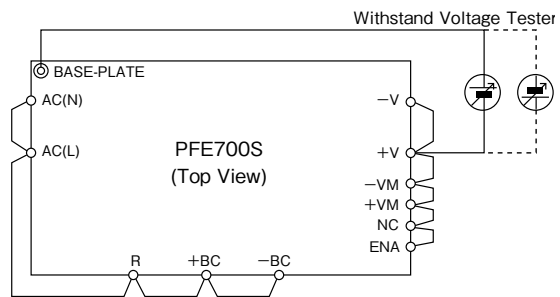

1.5kVDC 1 minute

Fig.16-3 Output to Baseplate Withstand Voltage Test Method

17 Insulation Resistance

Use DC Insulation Resistance test equipment (MAX.500V) between output and baseplate.

Insulation Resistance must be 100Mohm or more at 500VDC. Take caution that some types of test equipment generate high pulse voltage when switching applied voltage. After test, discharge this module using resistor, etc.

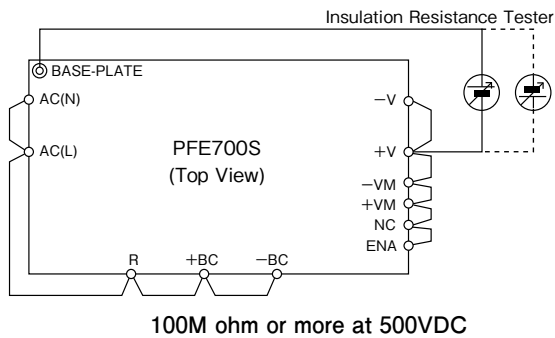

Fig. 17-1 Insulation Resistance Test Method

18 Recommended Soldering Condition

Recommended soldering temperature is as follows.

- (1) Soldering Dip : 260°C, within 10 seconds
- Preheat : 130°C, within 60 seconds
- (2) Soldering iron : 350°C, within 3 seconds

3. Before Concluding Power Module Damage

Verify following items before concluding power module damage.

1) No output voltage

- Is specified input voltage applied?
- Is there no abnormality with the output load?
- Is the actual baseplate temperature within the specified operating temperature of this module?

2) Output voltage is low

- Is specified input voltage applied?
- Is there no abnormality with the output load?

3) Load regulation or line regulation is large

- Is specified input voltage applied?
- Are the input or output terminals firmly connected?
- Are the input and output wires too thin?

4) Large output ripple

- Is the measurement done according to methods described Application Notes or is it an equivalent method?

TDK·Lambda

Precautions for Use

WARNING

- Do not modify, disassemble, or open this product. Failure to do so can cause electric shock hazard. TDK-Lambda cannot be held responsible for damage caused by modifications to this product.
- Internal voltage can be retained inside the product. Do not touch any parts inside the product because there can be high-voltage and high-temperature parts even when the electric current is not applied. This can cause an electric shock hazard or burn injury.
- There can be high-voltage and high-temperature parts even in products without a cover. Do not touch them. Touching them can cause an electric shock hazard or burn injury.
- While electric current is being applied, keep your hands and face away from it. This may cause injury or an unexpected accident.

CAUTION

- Be sure to read the catalogue and instruction manual before using this product. For strictly accurate information, request the specifications of the delivered product to check the information. Incorrect usage could lead to an electric shock, damage to the product or a fire hazard.
 - If there are differences between the specific information given for your product and this document, the specific information given for your product has priority.
 - Use this product within the specified input voltage, output power, output voltage, output current, and range of ambient temperature/ambient humidity. Using this product in conditions beyond the specification limits can shorten the lifetime of the product, or can cause, damage to the product, electric shock, or a fire hazard.
Also, measure the temperature inside the device to check that there are no problems.
 - Check the direction the product should face and the conditions for ventilation in the specifications of the delivered product, and use the product in the correct manner.
 - Disconnect the power input before connecting inputs and outputs.
 - If an internal fuse becomes burned out, do not use the unit by replacing the fuse. This can cause trouble inside the unit. Be sure to request us to repair the unit.
 - Insert fuses in the input circuit for products in which protection circuits (elements, fuses, etc.) are not installed, to prevent smoking or burning. Also for products with protection circuits installed inside, an appropriate use of protection circuits is recommended as there is possibility that the internal protection circuit may not operate depending on the usage conditions.
 - Use only the fuses specified or recommended by TDK-Lambda for external fuses.
 - This product is designed and manufactured as a component part to be installed in electronic devices. Attach the warning label to the unit and insert the notes in the instruction manual.
 - Malfunction and failure may be caused if this product is used in a strong electromagnetic field.
 - Failure may be caused in the power supply unit due to corrosion if used in environments with corrosive gas (hydrogen sulfide, sulfur dioxide, etc.).
 - Malfunction and failure may be caused if this product is used in environments with conductive substances or dust.
 - Be sure to take protective measures against the surge voltage caused by lightning, etc. Damage to the unit may be caused due to irregular voltage.
 - Connect the frame ground terminal of the power supply unit to the earth terminal of the device, for safety and to reduce noise. If grounding is not made, it may cause an electric shock hazard.
 - It is necessary to exchange consumable parts (built-in fan, electrolytic capacitor) periodically. Set an appropriate overhaul interval period for the performance of maintenance. There may be some cases where overhaul maintenance cannot be conducted due to unavailability of parts due to production discontinuation.
 - This product might fail accidentally or through unexpected conditions. When using this product with application devices, in which an extremely high reliability is required (Nuclear-related devices, traffic control devices, medical devices, etc.), be sure to ensure that the fail-safe function is effective in the devices.
- * As for EMI or immunity, they are measured in the TDK-Lambda standard conditions. It is not guaranteed that this product meets industry standards or regulations when being used in different conditions of mounting and wiring. Assess and evaluate values on the actual device before use.
- * To export this product, follow the necessary procedures of application for the export license by the government of Japan, etc., complying with the regulations of the Foreign Exchange and Foreign Trade Control Law.
- * The information in this catalogue is subject to change without prior notice.