

Front Panels

Screw-mounted front panel kits include handle and identification panel. Available in 3U, 6U and 9U heights and in three widths: 4HP (0.788"), 8HP (1.588") and 12HP (2.388"). All mounting hardware, including board mounting support bracket and hardware also included. Brushed aluminum panel with clear irridite plating matches standard finish for Vector packaging products.

Front Panels, Ejector Style, Type II

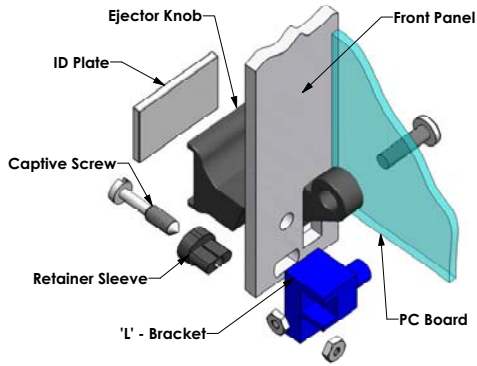

Part #	DESCRIPTION	A	B	C	D
FPE04-3U	3U X 4HP	5.06"	0.788"	N/A	N/A
FPE08-3U	3U X 8HP	5.06"	1.588"	N/A	N/A
FPE12-3U	3U X 12HP	5.06"	2.388"	N/A	N/A
FPE04-6U	6U X 4HP	10.31"	0.788"	3.50"	5.25"
FPE08-6U	6U X 8HP	10.31"	1.588"	3.50"	5.25"
FPE12-6U	6U X 12HP	10.31"	2.388"	3.50"	5.25"
FPE04-9U	9U X 4HP	15.56"	0.788"	3.50"	5.25"
FPE08-9U	9U X 8HP	15.56"	1.588"	3.50"	5.25"
FPE12-9U	9U X 12HP	15.56"	2.388"	3.50"	5.25"

-Add suffix "B" to part # for panels without center brackets mounting, e.g. FPE04-6UB

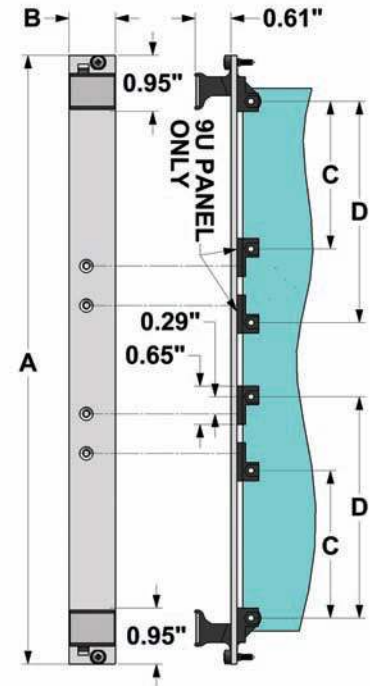

Non EMC Subracks

Front Panels, Fixed Handle Style, Type V

Type V, 3U Fixed Handle Style

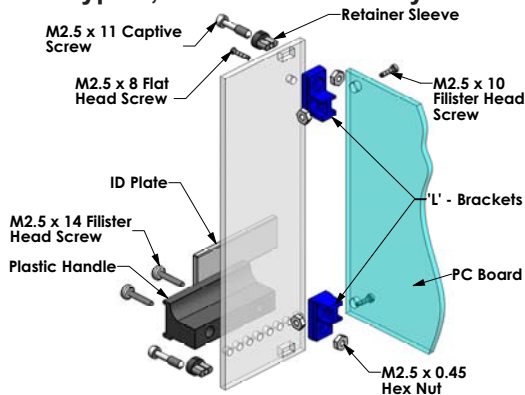

Part #	DESCRIPTION	A	B
FP04-3U	3U X 4HP	5.06"	0.788"
FP08-3U	3U X 8HP	5.06"	1.588"
FP12-3U	3U X 12HP	5.06"	2.388"
FP04-6U	6U X 4HP	10.31"	0.788"
FP08-6U	6U X 8HP	10.31"	1.588"
FP12-6U	6U X 12HP	10.31"	2.388"
FP04-9U	9U X 4HP	15.56"	0.788"
FP08-9U	9U X 8HP	15.56"	1.588"
FP12-9U	9U X 12HP	15.56"	2.388"

-Fixed Handle Style front panel kit includes upper and lower handles (lower only on 3U versions) that extend across the full width of the panel

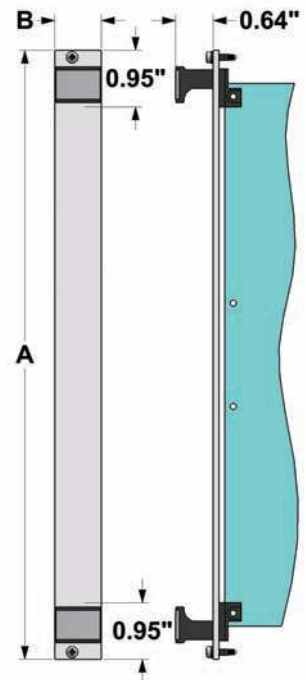

Custom Front Panels

Whether you need standard panels, modified, or custom front panels, we have manufacturing capabilities to support your needs. Vector Electronics's custom aluminum front panels offer a wide range of design opportunities. Cost effective punching for volume production.

Customization :

- Panel cutouts
- Silkscreening
- Powder coating
- Special Finishing

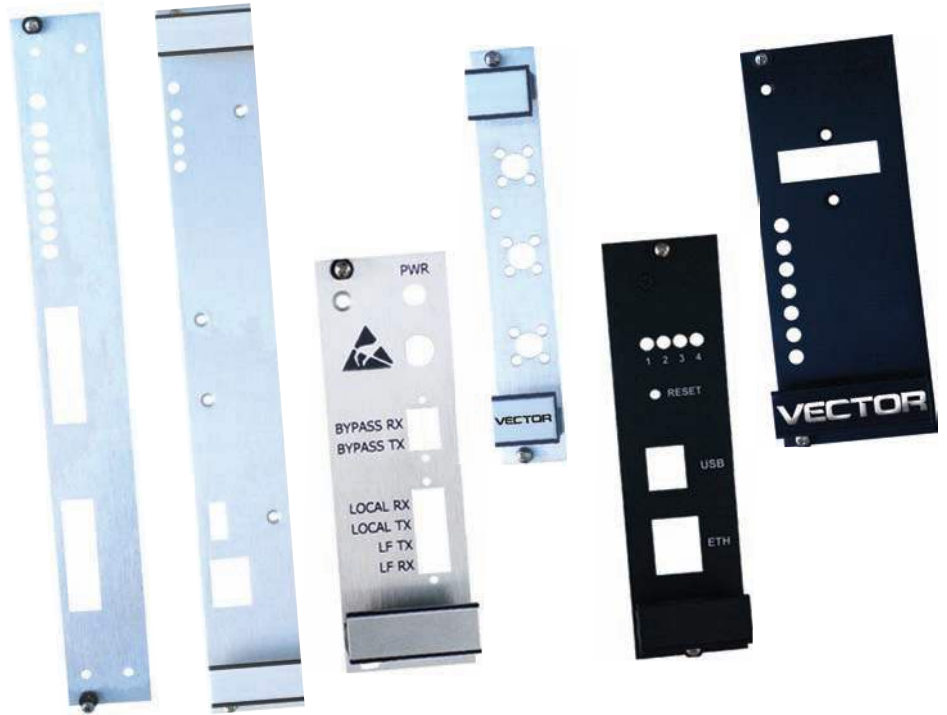

Standard Filler Panels

Non EMC Subracks

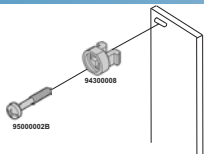

Captive sleeves/screws are included with all VectorPak™ filler panels and also sold separately in a hardware kit:

P/N HD99-1

Includes	Qty
Black plastic sleeve	48
M2.5 x 11 mm, nickel plated steel screw	48

Filler Panels/Blank-off Plates Features

- Covers unused slots
- Improves air flow
- Mounting hardware included

Typical slot width is 0.800" (4HP)
Material: 6063T5, extruded brushed Aluminum with clear Irridite finish.

Each Filler Panel Kit Includes

4,8 or 12HP panel (0.8", 1.6" or 2.4")

M2.5 Nickel plated mounting screws with 'captive' sleeves

U	Part Number 4HP	Part Number 8HP	Part Number 12HP
3	5231304-07	5231308-07	5231312-07
6	5261304-07	5261308-07	5261312-07
9	5291304-07	5291308-07	5291312-07

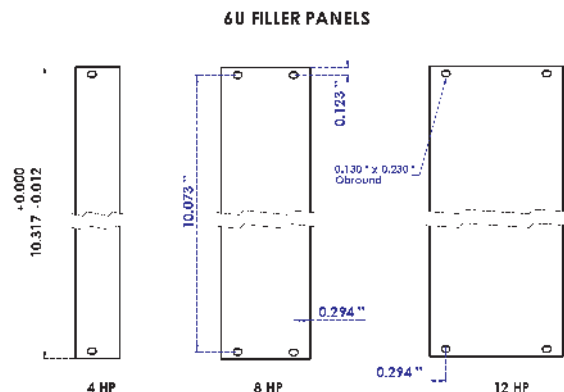
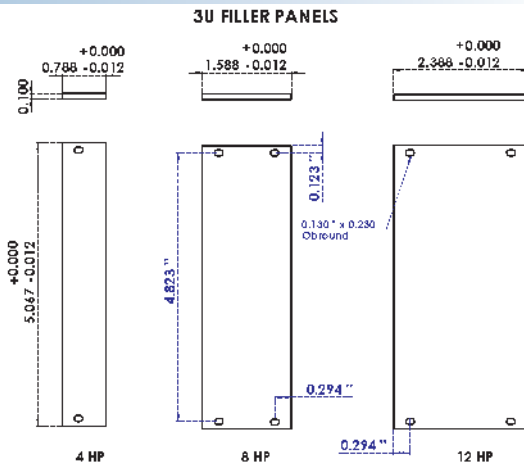

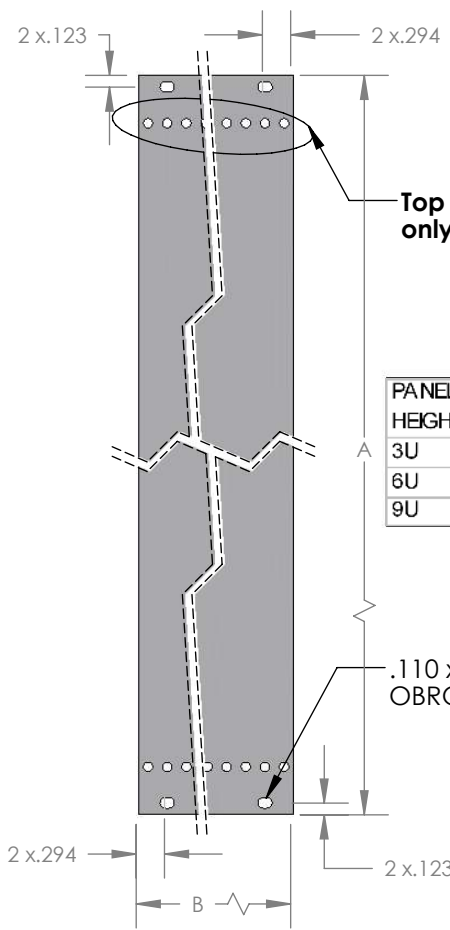

PANEL HEIGHT	A
3U	5.067
6U	10.317
9U	15.567

PANEL WIDTH	B
4 HP	0.788
8 HP	1.588
12 HP	2.388

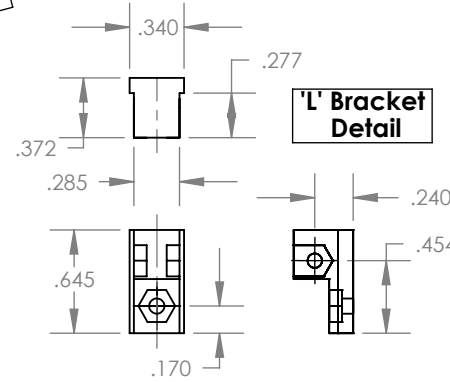
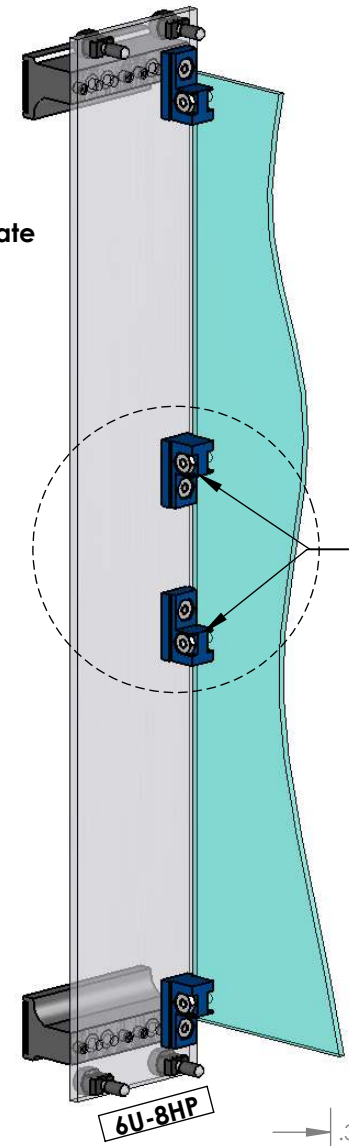
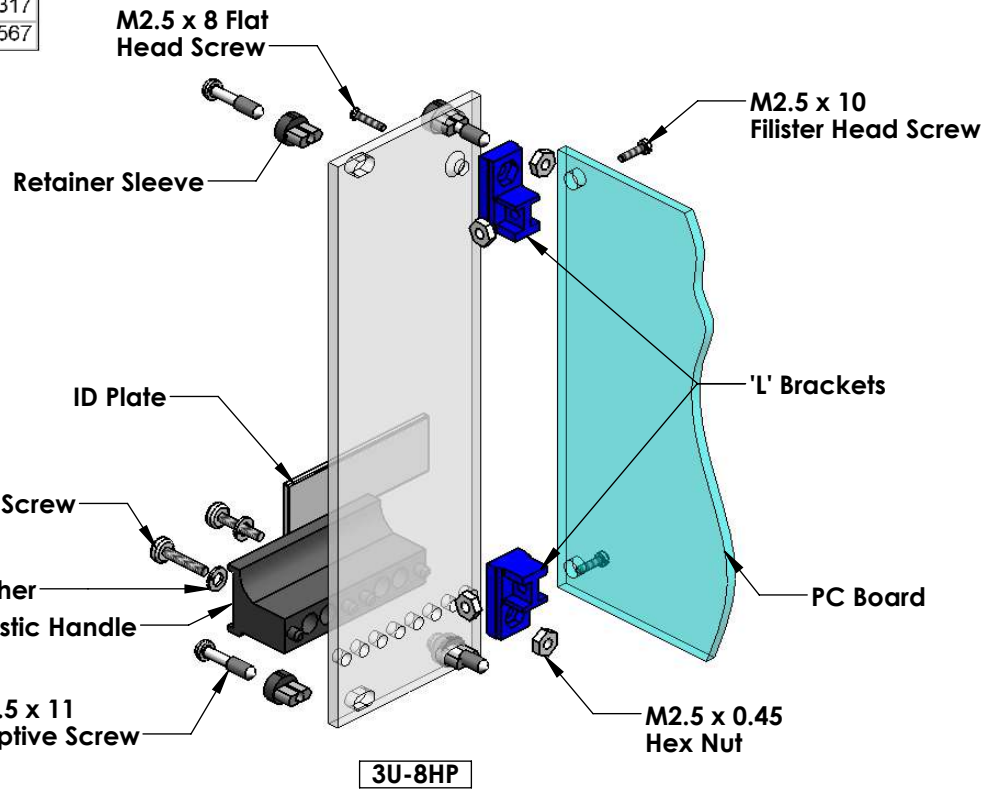
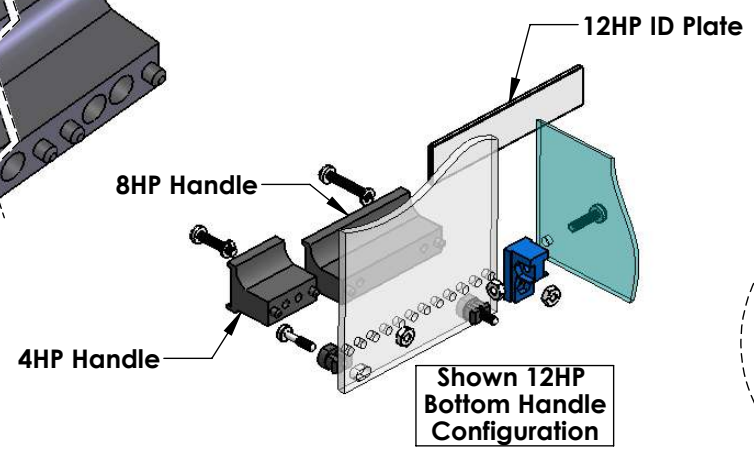
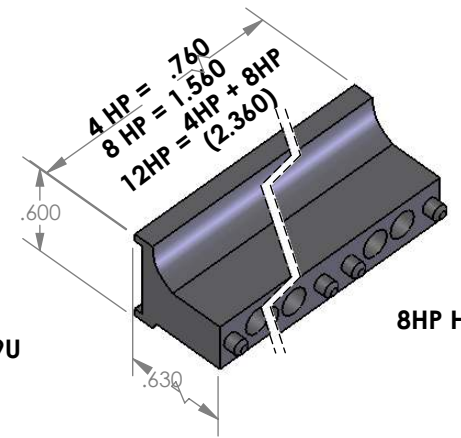

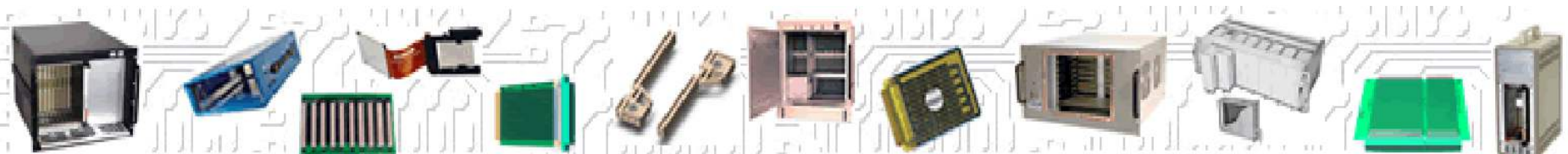

IN399

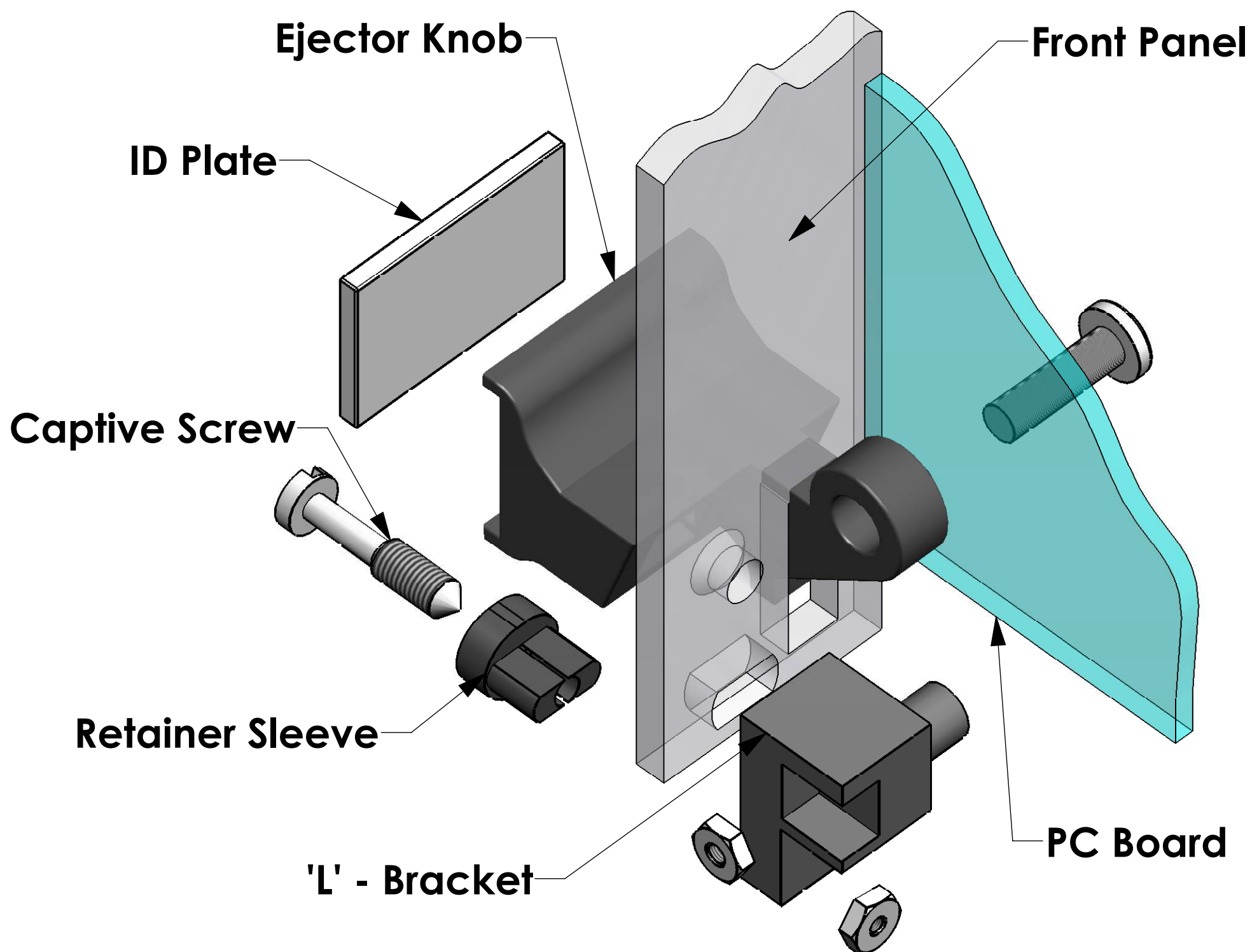
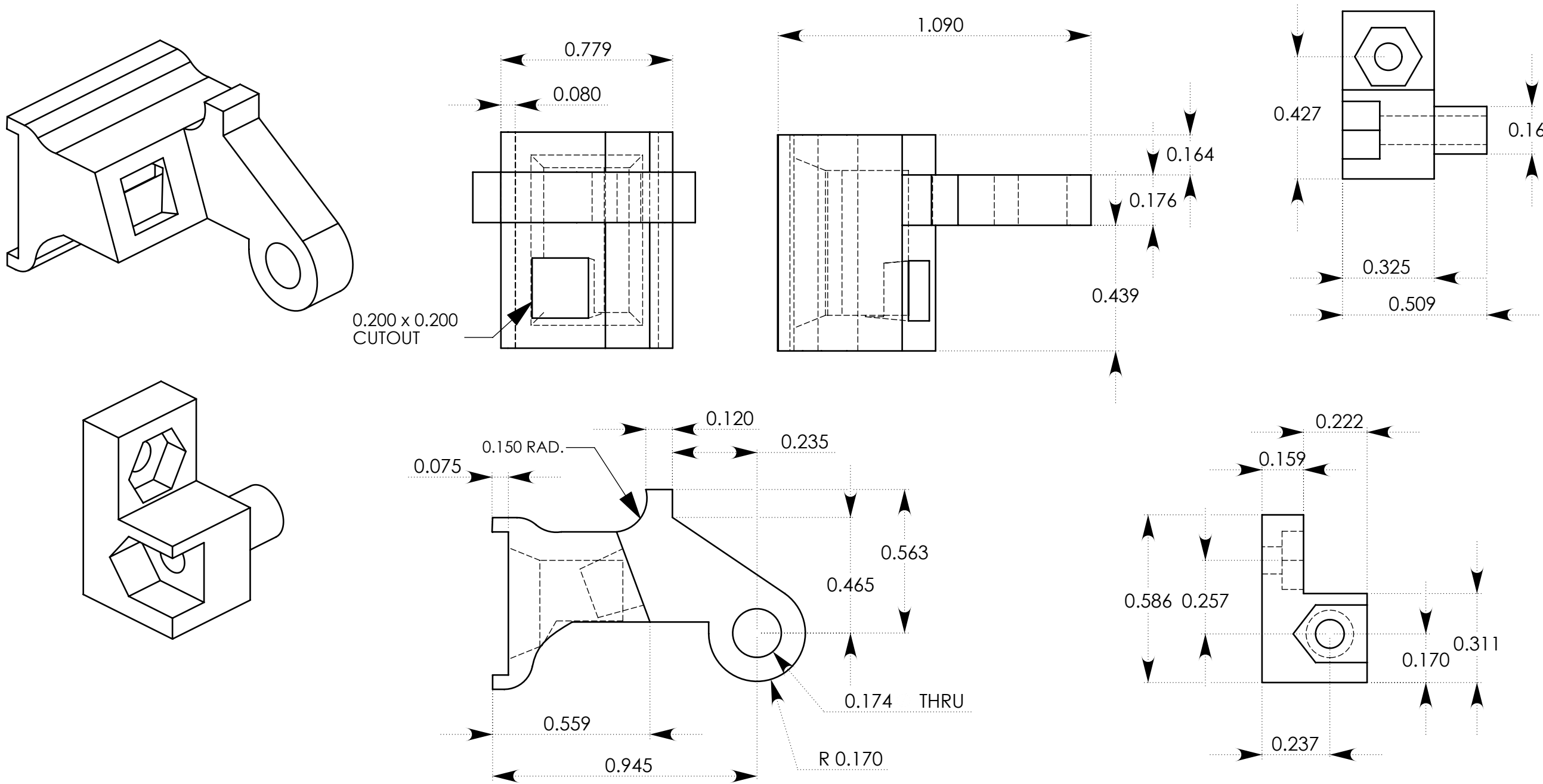

***FPE04-6U* PANEL WILL HAVE TWO CENTER HOLES FOR OPTIONAL 3U 'L' BRACKETS.
ORDER *FPE04-6UB* FOR PANEL WITHOUT THE CENTER HOLES.**