

NOTES:

1. ELECTRICAL:

- A: IMPEDENCE: 50Ω, NOMINAL
- B: FREQUENCY RANGE: 0-6GHz (VSWR 1.3 MAX.)
- C: OPERATING VOLTAGE: 60 VAC
- D. CONTACT RESISTANCE:
 - CENTER CONTACT: INITIAL: 20 mΩ MAX.
AFTER: 25 mΩ MAX.
 - OUTER CONTACT: INITIAL: 10 mΩ MAX.
AFTER: 15 mΩ MAX.
- E. DIELECTRIC WITHSTANDING VOLTAGE: 200 VAC
- F. INSULATION RESISTANCE: 500 MEGOHMS MIN.

2. PHYSICAL:

- A. TEMPERATURE RANGE: -40°C TO +90°C
- B. AMC INTERFACE IS FULLY COMPATIBLE WITH "U.FL" SERIES PRODUCT.
- C. SUITABLE FOR SOLDER REFLOW PROCESS.

3. MATERIALS AND FINISHES(PLATING THICKNESS IN MICRO-INCHES):

- HOUSING: HIGH TEMP. PLASTIC UL94V-0/WHITE
- CENTER CONTACT: COPPER ALLOY, AU 5 MIN. PLATED OVER NI
- GROUND CONTACT: COPPER ALLOY, AG 100 MIN. PLATED OVER NI

4. PACKAGING:

- A. TAPE AND REEL PACKAGING.
- B. QTY : 2500 PCS/REEL.
- C. LEAVE 20 EMPTY POCKETS IN THE BEGINNING AND END OF EACH REEL.

THIRD ANGLE PROJ.

REVISIONS

REV	DESCRIPTION	DATE	ECO	APPR
A	RELEASE TO MFG.	5/7/04	44924	HP
G	CENTER CONTACT WAS BRASS, FLATNESS REQUIREMENT, REMOVED MFG LOCATION STAMP, OPERATING VOLTAGE WAS 500 VRMS	3/3/14	49763	EW
H	REMOVED DRAWING RELICS	23-May-14	49937	EW
J	REDRAWN IN PRO-E, FIXED DOC ERROR\RD-DMI409050ITI	10-Sep-14	50053	SH
K	ADD PPAP NOTE	2/5/16	50957	EW

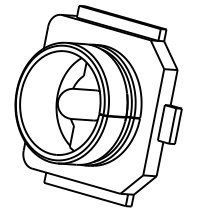
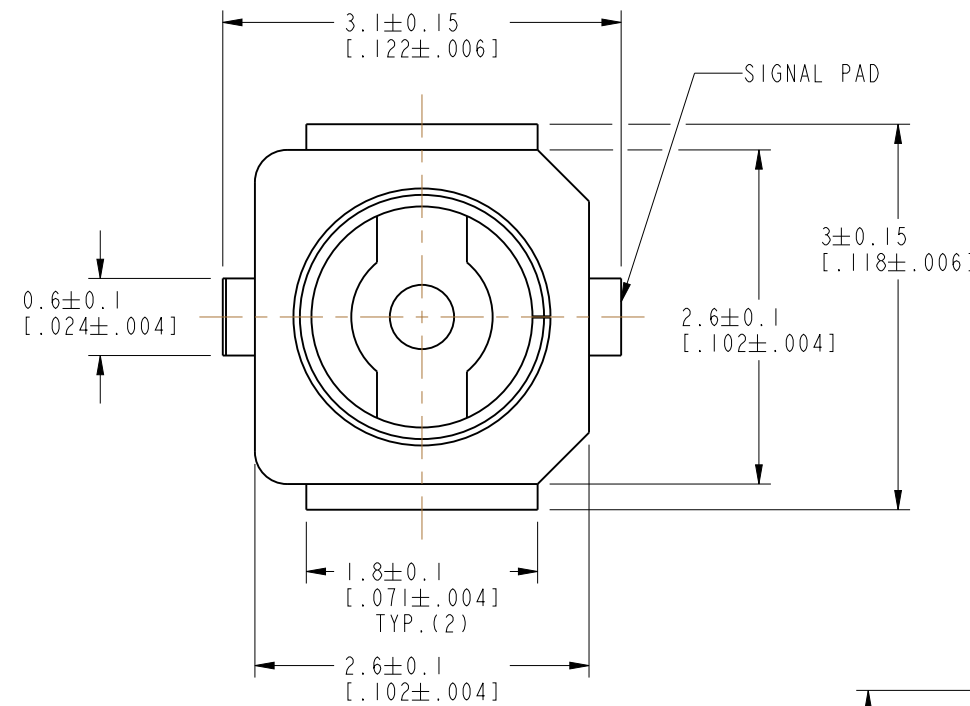

SCALE 8.000

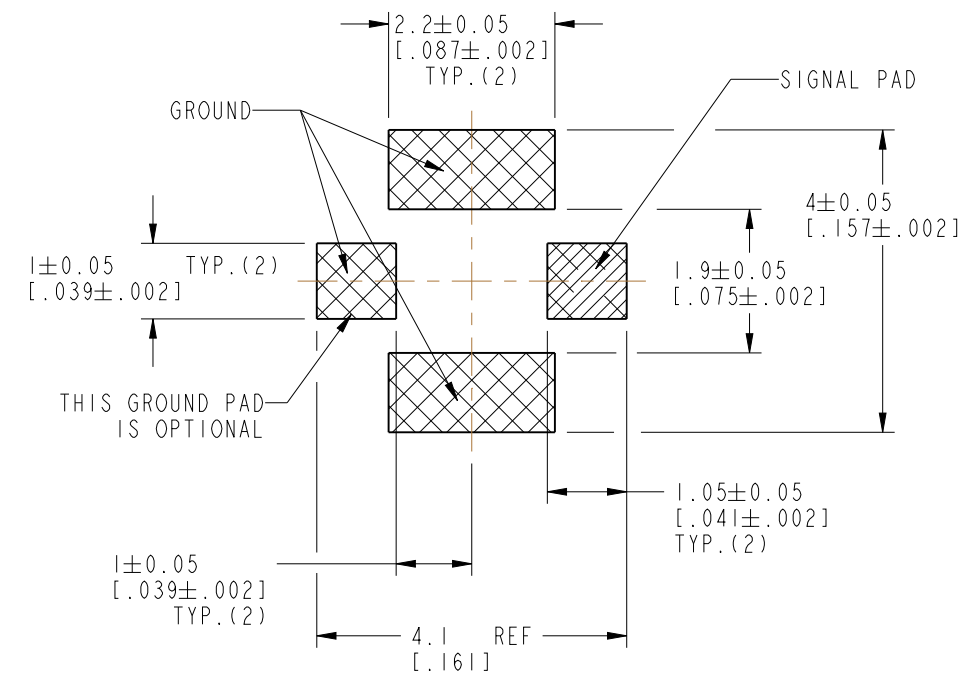

RECOMMENDED PCB PATTERN

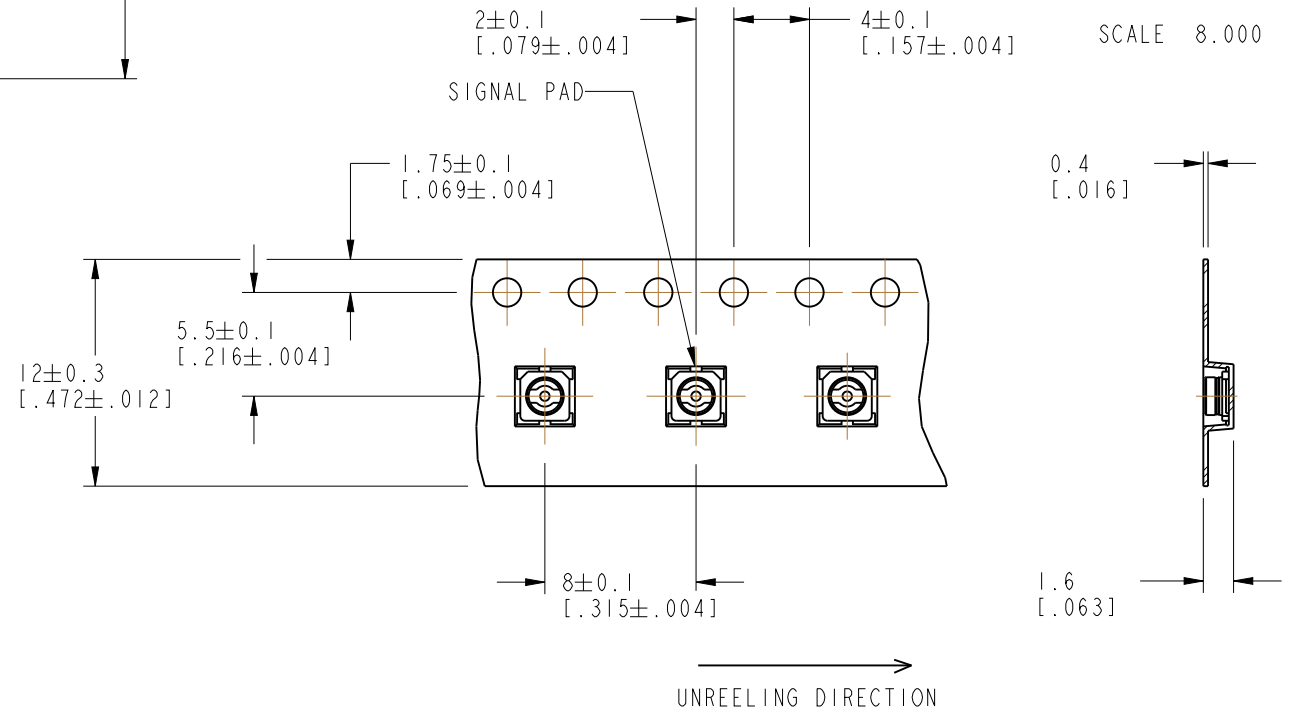
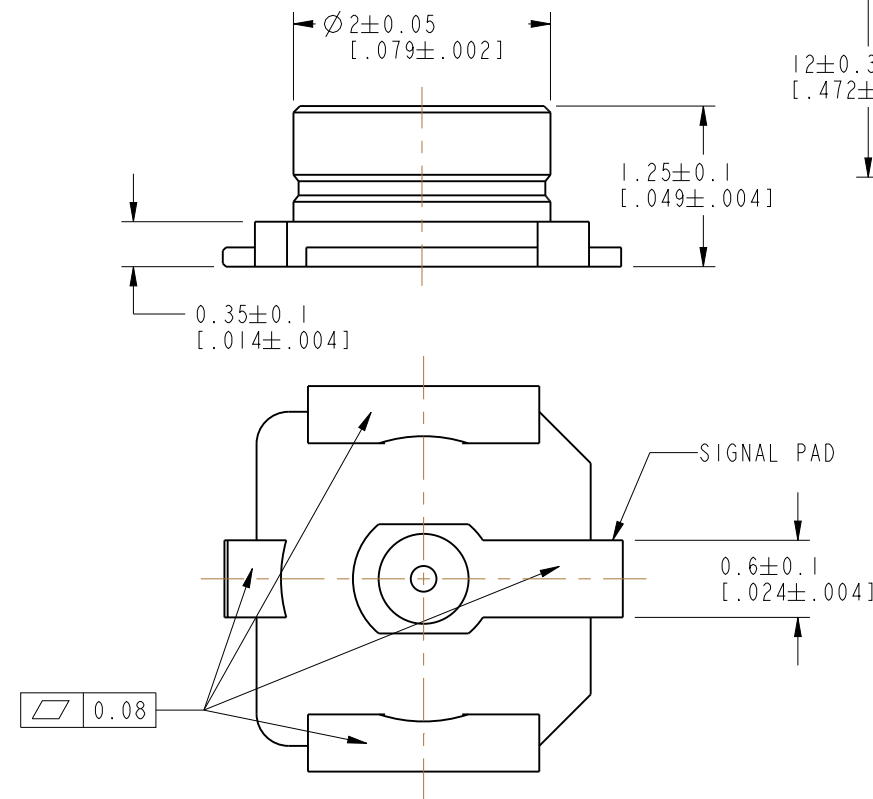

SCALE 2.500
EMBOSSED CARRIER TAPE DIMENSIONS

**CONFIGURATION CONTROL:
NO CHANGES PERMITTED TO DRAWING WITHOUT
PPAP QUALIFIED CUSTOMER APPROVAL**

CUSTOMER OUTLINE DRAWING

ALL OTHER SHEETS ARE FOR INTERNAL USE ONLY

UNLESS OTHERWISE SPECIFIED, DIMENSIONS ARE IN METRIC AND TOLERANCES ARE: <0.5mm ±0.05mm 0.5 - 6mm ±0.1mm 6 - 30mm ±0.2mm 30 - 120mm ±0.3mm ANGLES ±1°	MATERIAL	DRAWN TANGOR	DATE 10-Sep-14	TITLE AMC PCB JACK SURFACE MOUNT TAPE & REEL	Amphenol RF www.amphenolrf.com
	NOTICE - These drawings, specifications, or other data (1) are, and remain the property of Amphenol corp. (2) must be returned upon request; and (3) are confidential and not to be disclosed to any person other than those to whom they are given by Amphenol Corp. the furnishing of these drawings, specifications, or other data by Amphenol Corp., or to any other person to anyone for any purpose is not to be regarded by implication or otherwise in any manner licensing, granting rights to permitting such holder or any other person to manufacture, use or sell any product, process or design, patented or otherwise, that may in any way be related to or disclosed by said drawings, specifications, or other data.	REFERENCE EAR # 966	ENGINEER G. ANTONINI		
CONFIGURATION LEVEL:	APPROVED O. BARTHELMES	DATE 5/7/14	SCALE: 17.0:1.0 SHEET 1 OF 1	ITEM NO. A-IJB	
FINISH	CAD FILE	DWG SIZE B	REV K	PART NO. A-IJB	