



# HA-2542

## Wideband, High Slew Rate, High Output Current Operational Amplifier

March 1993

### Features

- Stable at Gains of 2 or Greater
- Gain Bandwidth ..... 70MHz
- High Slew Rate (Min) ..... 300V/ $\mu$ s
- High Output Current (Min) ..... 100mA
- Power Bandwidth (Typ) ..... 5.5MHz
- Output Voltage Swing (Min) .....  $\pm$ 10V
- Monolithic Bipolar Dielectric Isolation Construction

### Applications

- Pulse and Video Amplifiers
- Wideband Amplifiers
- Coaxial Cable Drivers
- Fast Sample-Hold Circuits
- High Frequency Signal Conditioning Circuits

### Description

The HA-2542 is a wideband, high slew rate, monolithic operational amplifier featuring an outstanding combination of speed, bandwidth, and output drive capability.

Utilizing the advantages of the Harris D.I. technology this amplifier offers 350V/ $\mu$ s slew rate, 70MHz gain bandwidth, and  $\pm$ 100mA output current. Application of this device is further enhanced through stable operation down to closed loop gains of 2.

For additional flexibility, offset null and frequency compensation controls are included in the HA-2542 pinout.

The capabilities of the HA-2542 are ideally suited for high speed coaxial cable driver circuits where low gain and high output drive requirements are necessary. With 5.5MHz full power bandwidth, this amplifier is most suitable for high frequency signal conditioning circuits and pulse video amplifiers. Other applications utilizing the HA-2542 advantages include wideband amplifiers and fast sample-hold circuits.

For more information on the HA-2542, please refer to Application Note 552 (Using the HA-2542), or Application Note 556 (Thermal Safe-Operating-Areas for High Current Op Amps).

### Ordering Information

PART NUMBER	TEMP. RANGE	PACKAGE
HA1-2542-2	-55°C to +125°C	14 Lead Ceramic DIP
HA1-2542-5	0°C to +75°C	14 Lead Ceramic DIP
HA2-2542-2	-55°C to +125°C	12 Pin Can
HA2-2542-5	0°C to +75°C	12 Pin Can
HA3-2542-5	0°C to +75°C	14 Lead Plastic DIP

For a lower power version of this product, please see the HA-2842 data sheet.

### Pinouts

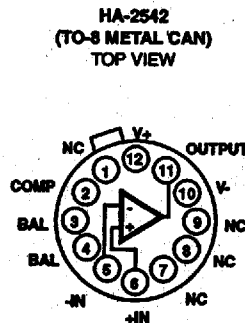
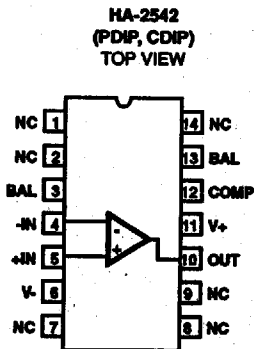

**Absolute Maximum Ratings (Note 1)**

Supply Voltage (Between V+ and V- Terminals).....	35V
Differential Input Voltage.....	6V
Output Current.....	125mA (Peak)
	50mA (Continuous)
Junction Temperature (Note 11).....	+175°C
Junction Temperature (Plastic Package).....	+150°C
Lead Temperature (Soldering 10 Sec.).....	+300°C

**Operating Conditions**

Operating Temperature Range	$-55^{\circ}\text{C} \leq T_A \leq +125^{\circ}\text{C}$
HA-2542-2.....	$-55^{\circ}\text{C} \leq T_A \leq +125^{\circ}\text{C}$
HA-2542-5.....	$0^{\circ}\text{C} \leq T_A \leq +75^{\circ}\text{C}$
Storage Temperature Range.....	$-65^{\circ}\text{C} \leq T_A \leq +150^{\circ}\text{C}$

CAUTION: Stresses above those listed in "Absolute Maximum Ratings" may cause permanent damage to the device. This is a stress only rating and operation of the device at these or any other conditions above those indicated in the operational sections of this specification is not implied.

**Electrical Specifications**  $V_{\text{SUPPLY}} = \pm 15\text{V}$ ,  $R_L = 1\text{k}\Omega$ ,  $C_L \leq 10\text{pF}$ , Unless Otherwise Specified.

PARAMETER	TEMPERATURE	HA-2542-2 -55°C to +125°C			HA-2542-5 0°C to +75°C			UNITS
		MIN	TYP	MAX	MIN	TYP	MAX	
<b>INPUT CHARACTERISTICS</b>								
Offset Voltage	+25°C	-	5	10	-	5	10	mV
	Full	-	8	20	-	8	20	mV
Average Offset Voltage Drift	Full	-	14	-	-	14	-	$\mu\text{V}/^{\circ}\text{C}$
Bias Current	+25°C	-	15	35	-	15	35	$\mu\text{A}$
	Full	-	26	50	-	26	50	$\mu\text{A}$
Average Bias Current Drift	Full	-	66	-	-	45	-	$\text{nA}/^{\circ}\text{C}$
Offset Current	+25°C	-	1	7	-	1	7	$\mu\text{A}$
	Full	-	-	9	-	-	9	$\mu\text{A}$
Input Resistance	+25°C	-	100	-	-	100	-	k $\Omega$
Input Capacitance	+25°C	-	1	-	-	1	-	pF
Common Mode Range	Full	$\pm 10$	-	-	$\pm 10$	-	-	V
Input Noise Voltage (0.1Hz to 100Hz)	+25°C	-	2.2	-	-	2.2	-	$\mu\text{V}_{\text{R-P}}$
Input Noise Density (f = 1kHz, $R_G = 0\Omega$ )	+25°C	-	10	-	-	10	-	$\text{nV}/\sqrt{\text{Hz}}$
Input Noise Current Density (f = 1kHz, $R_G = 0\Omega$ )	+25°C	-	3	-	-	3	-	$\text{pA}/\sqrt{\text{Hz}}$
<b>TRANSFER CHARACTERISTICS</b>								
Large Signal Voltage Gain (Note 3)	+25°C	10	30	-	10	30	-	kV/V
	Full	5	15	-	5	20	-	kV/V
Common Mode Rejection Ratio (Note 4)	Full	70	100	-	70	100	-	dB
Minimum Stable Gain	+25°C	2	-	-	2	-	-	V/V
Gain Bandwidth Product (Note 5)	+25°C	-	70	-	-	70	-	MHz
<b>OUTPUT CHARACTERISTICS</b>								
Output Voltage Swing	Full	$\pm 10$	$\pm 11$	-	$\pm 10$	$\pm 11$	-	V
Output Current (Note 6)	+25°C	100	-	-	100	-	-	mA
Output Resistance	+25°C	-	5	-	-	5	-	$\Omega$
Full Power Bandwidth (Notes 3, 7)	+25°C	4.7	5.5	-	4.7	5.5	-	MHz
Differential Gain (Note 2)	+25°C	-	0.1	-	-	0.1	-	%
Differential Phase (Note 2)	+25°C	-	0.2	-	-	0.2	-	Degree
Harmonic Distortion (Note 10)	+25°C	-	<0.04	-	-	<0.04	-	%
<b>TRANSIENT RESPONSE (Note 8)</b>								
Rise Time	+25°C	-	4	-	-	4	-	ns
Overshoot	+25°C	-	25	-	-	25	-	%
Slew Rate	+25°C	300	350	-	300	350	-	V/ $\mu\text{s}$

2  
**OPERATIONAL  
 AMPLIFIERS**

## Specifications HA-2542

Electrical Specifications  $V_{SUPPLY} = \pm 15V$ ,  $R_L = 1k\Omega$ ,  $C_L \leq 10pF$ , Unless Otherwise Specified. (Continued)

PARAMETER	TEMPERATURE	HA-2542-2 -55°C to +125°C			HA-2542-5 0°C to +75°C			UNITS
		MIN	TYP	MAX	MIN	TYP	MAX	
<b>TRANSIENT RESPONSE (Note 8) Continued</b>								
<b>Settling Time</b>								
10V Step to 0.1%	+25°C	-	100	-	-	100	-	ns
10V Step to 0.01%	+25°C	-	200	-	-	200	-	ns
<b>POWER SUPPLY CHARACTERISTICS</b>								
Supply Current	+25°C	-	30	-	-	30	-	mA
	Full	-	31	34.5	-	31	40	mA
Power Supply Rejection Ratio (Note 9)	Full	70	79	-	70	79	-	dB

## NOTES:

- Absolute maximum ratings are limiting values, applied individually, beyond which the serviceability of the circuit may be impaired. Functional operability under any of these conditions is not necessarily implied.
- Differential gain and phase are measured at 5MHz with a 1V differential input voltage.
- $R_L = 1k\Omega$ ,  $V_O = \pm 10V$ .
- $V_{CM} = \pm 10V$ .
- $A_{VCL} = 100$ .
- $R_L = 50\Omega$ ,  $V_O = \pm 5V$ , Output duty cycle must be reduced for  $I_{OUT} > 50mA$  (e.g.  $\leq 50\%$  duty cycle for 100mA).
- Full Power Bandwidth guaranteed based on slew rate measurement using  $FPBW = \frac{\text{Slew Rate}}{2\pi V_{PEAK}}$ .
- Refer to Test Circuits section of this data sheet.
- $V_{SUPPLY} = \pm 5VDC$  to  $\pm 15VDC$ .
- $V_{IN} = 1V_{RMS}$ ;  $f = 10kHz$ ;  $A_V = 10$ .
- Maximum power dissipation with load conditions must be designed to maintain the maximum junction temperature below +175°C for ceramic and can packages, and below +150°C for plastic packages. By using Application Note 556 on Safe Operating Area equations, along with the packaging thermal resistances listed in the Die Characteristics section, proper load conditions can be determined. Heat-sinking will be required in many applications. See Performance Curve below to determine if heat sinking is required for your application. Some suggested heatsink models are:  
 14 Lead Ceramic DIP:  
 Thermalloy #6007 or AAVID #5602B ( $\theta_{SA} = 16^\circ C/W$ )  
 12 Pin Metal Can (TO-8):  
 Thermalloy #2240A ( $\theta_{SA} = 27^\circ C/W$ ) or #2268B ( $\theta_{SA} = 24^\circ C/W$ )

## Die Characteristics

Transistor Count	43	
Die Dimensions	72 x 105 x 19 mils (1820 $\mu m$ x 2670 $\mu m$ x 485 $\mu m$ )	
Substrate Potential*	-V	
Process	High Frequency Bipolar-DI	
Passivation	Nitride	
Thermal Package Characteristics ( $^\circ C/W$ )	$\theta_{JA}$	$\theta_{JC}$
Ceramic DIP	71	13
Plastic DIP	88	27
Metal Can	56	29

\* The substrate may be left floating (Insulating Die Mount) or it may be mounted on a conductor at -V potential.

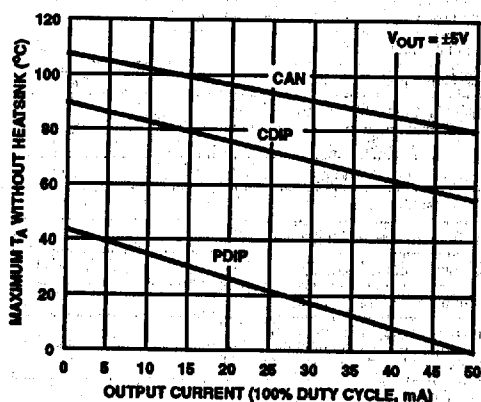

MAXIMUM OPERATING TEMPERATURE vs OUTPUT CURRENT

Schematic Diagram

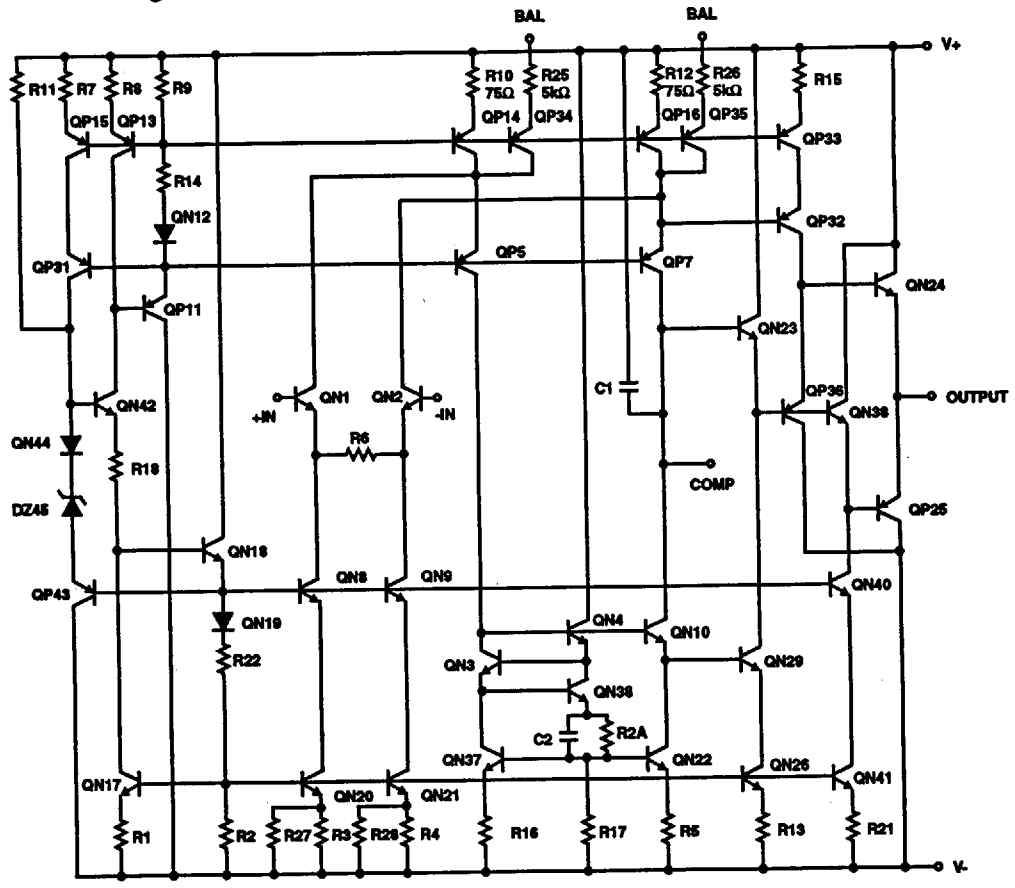

2  
OPERATIONAL  
AMPLIFIERS

**Test Circuits**

**TEST CIRCUIT**

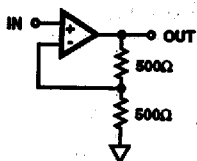

$V_S = \pm 15V$   
 $A_V = +2$   
 $C_L \leq 10pF$

**LARGE SIGNAL RESPONSE**  
Vertical Scale (Volts:  $V_{IN} = 2.0V/Div.$ ,  $V_{OUT} = 5.0V/Div.$ )  
Horizontal Scale (Time: 200ns/Div.)

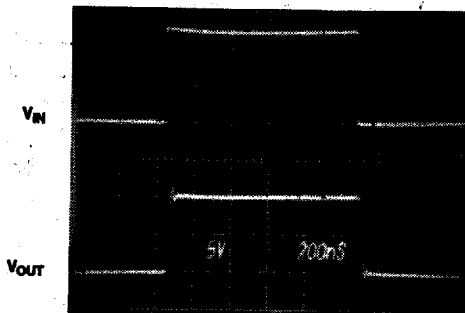

**SMALL SIGNAL RESPONSE**  
Vertical Scale (Volts: 100mV/Div.)  
Horizontal Scale (Time: 50ns/Div.)

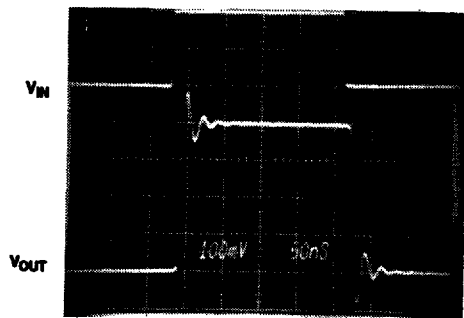

**PROPAGATION DELAY**  
Vertical Scale (Volts: 100mV/Div.)  
Horizontal Scale (Time: 10ns/Div.)

$V_S = \pm 15V$ ,  $R_L = 1k\Omega$ . Propagation delay variance is negligible over full temperature range

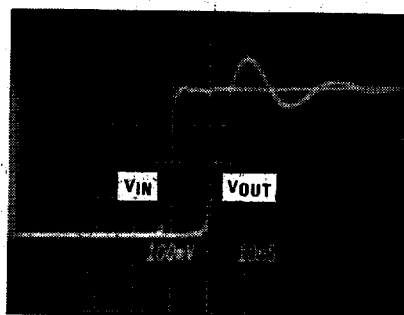

**SETTLING TIME TEST CIRCUIT**

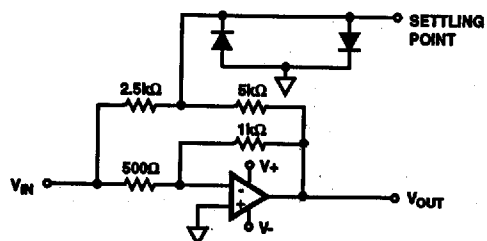

- $A_V = -2$ .
- Feedback and summing resistors must be matched (0.1%).
- HP5082-2810 clipping diodes recommended.
- Tektronix P6201 FET probe used at settling point.
- For 0.01% settling time, heat sinking is suggested to reduce thermal effects and an analog ground plane with supply decoupling is suggested to minimize ground loop errors.

Typical Performance Curves

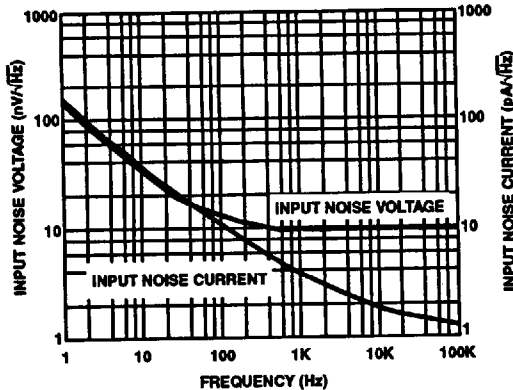

FIGURE 1. INPUT NOISE VOLTAGE AND INPUT NOISE CURRENT vs FREQUENCY

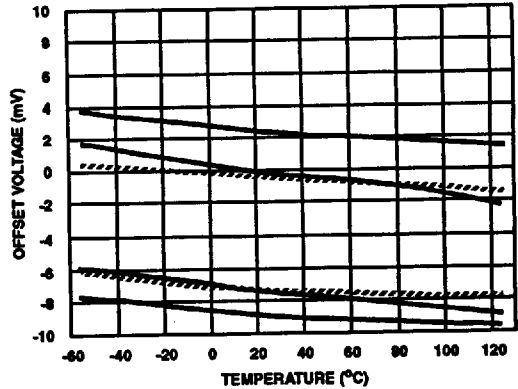

FIGURE 2. OFFSET VOLTAGE DRIFT WITH TEMPERATURE OF SIX REPRESENTATIVE UNITS ( $V_S = \pm 12V$ )

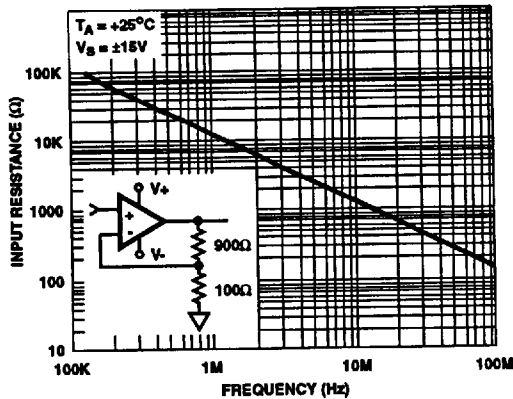

FIGURE 3. INPUT RESISTANCE vs FREQUENCY

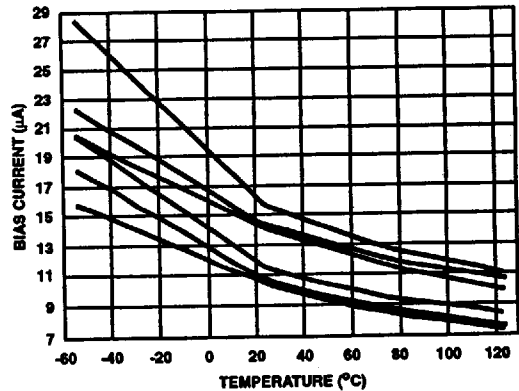

FIGURE 4. BIAS CURRENT DRIFT WITH TEMPERATURE OF SIX REPRESENTATIVE UNITS ( $V_S = \pm 12V$ )

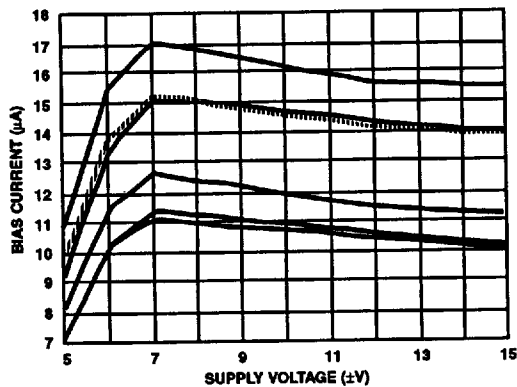

FIGURE 5. BIAS CURRENT vs POWER SUPPLY, SIX UNITS AT VARIOUS SUPPLIES AT +25°C

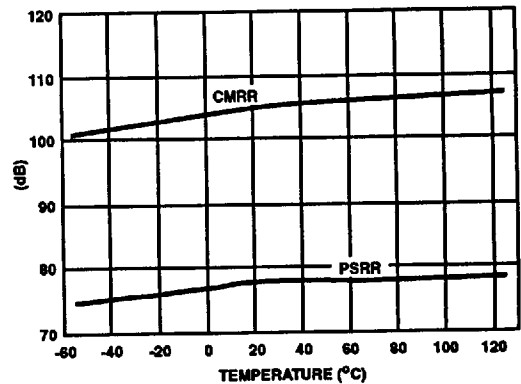

FIGURE 6. PSRR AND CMRR vs TEMPERATURE ( $V_S = \pm 15V$ )

Typical Performance Curves (Continued)

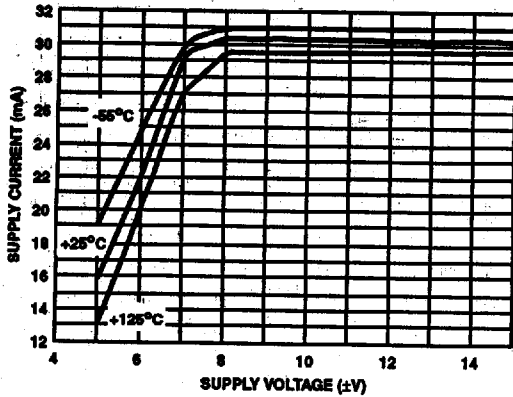

FIGURE 7. SUPPLY CURRENT vs SUPPLY VOLTAGE, AT VARIOUS TEMPERATURES

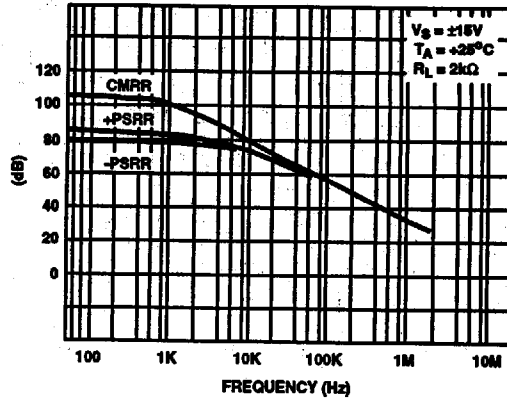

FIGURE 8. PSRR AND CMRR vs FREQUENCY

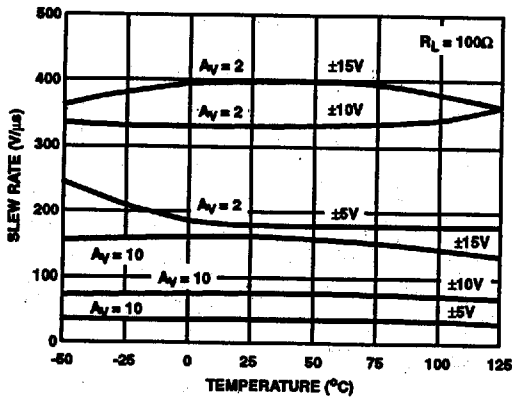

FIGURE 9. SLEW RATE vs TEMPERATURE AT VARIOUS SUPPLY VOLTAGES

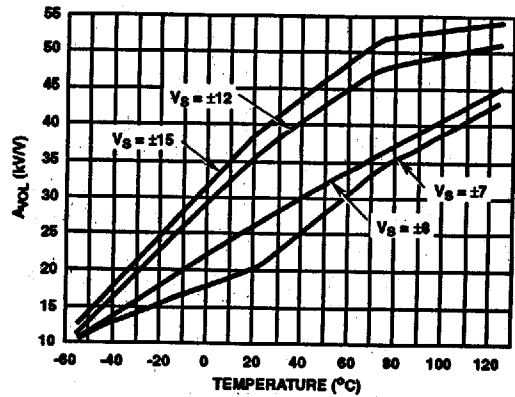

FIGURE 10. OPEN LOOP GAIN vs TEMPERATURE, AT VARIOUS SUPPLY VOLTAGES

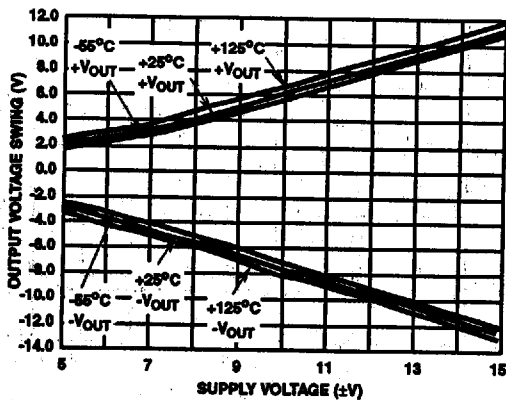

FIGURE 11. OUTPUT VOLTAGE SWING vs SUPPLY VOLTAGE, AT VARIOUS TEMPERATURES

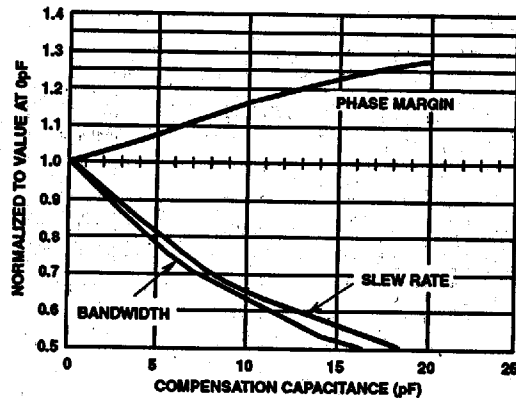

FIGURE 12. NORMALIZED AC PARAMETERS vs COMPENSATION CAPACITANCE

Typical Performance Curves (Continued)

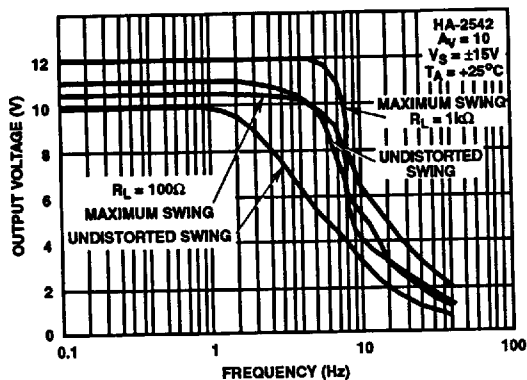

FIGURE 13. OUTPUT VOLTAGE SWING vs FREQUENCY

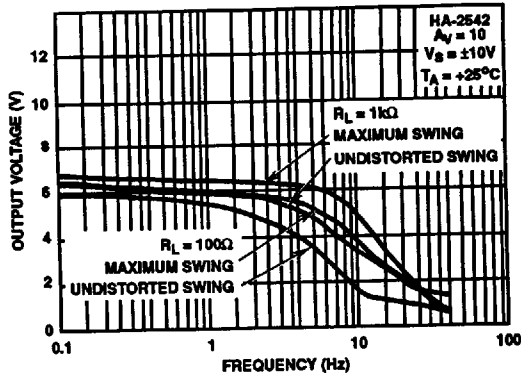

FIGURE 14. OUTPUT VOLTAGE SWING vs FREQUENCY

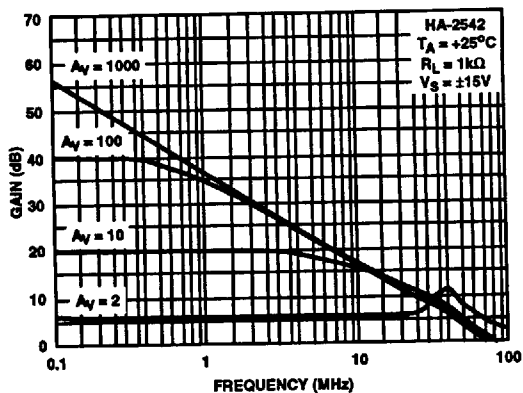

FIGURE 15. FREQUENCY RESPONSE CURVES

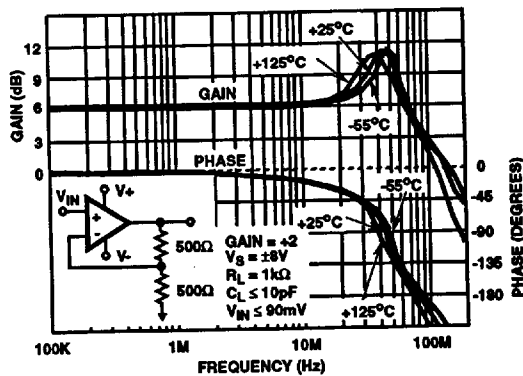

FIGURE 16. HA-2542 CLOSED LOOP GAIN vs TEMPERATURE

2  
OPERATIONAL  
AMPLIFIERS



## HA-2542

## Application Information

### Typical Applications

(Refer to Application Note 552 for Further Information)

The Harris HA-2542 is a state of the art monolithic device which also approaches the "ALL-IN-ONE" amplifier concept. This device features an outstanding set of AC parameters augmented by excellent output drive capability providing for suitable application in both high speed and high output drive circuits.

Primarily intended to be used in balanced 50Ω and 75Ω coaxial cable systems as a driver, the HA-2542 could also be used as a power booster in audio systems as well as a power amp in power supply circuits. This device would also be suitable as a small DC motor driver.

The applications shown in Figures 17 through Figure 19 demonstrate the HA-2542 at gains of +100 and +2 and as a video cable driver for small signals.

### Prototyping Guidelines

For best overall performance in any application, it is recommended that high frequency layout techniques be used. This should include: 1) mounting the device through a ground plane; 2) connecting unused pins (N.C.) to the ground; 3) mounting feedback components on Teflon standoffs and/or locating these components as close to the device as possible; 4) placing power supply decoupling capacitors from device supply pins to ground.

As a result of speed and bandwidth optimization, the HA-2542 can's case potential, when powered-up, is equal to the V- potential. Therefore, contact with other circuitry or ground should be avoided.

### Frequency Compensation

The HA-2542 may be externally compensated with a single capacitor to ground. This provides the user the additional flexibility in tailoring the frequency response of the amplifier. A guideline to the response is demonstrated on the typical performance curve showing the normalized A.C. parameters versus compensation capacitance. It is suggested that the user check and tailor the accurate compensation value for each application. As shown additional phase margin is achieved at the loss of slew rate and bandwidth.

For example, for a voltage gain of +2 (or -1) and a load of 500pF/2kΩ, 20pF is needed for compensation to give a small signal bandwidth of 30MHz with 40° of phase margin. If a full power output voltage of ±10V is needed, this same configuration will provide a bandwidth of 5MHz and a slew rate of 200V/μs.

If maximum bandwidth is desired and no compensation is needed, care must be given to minimize parasitic capacitance at the compensation pin. In some cases where minimum gain applications are desired, bending up or totally removing this pin may be the solution. In this case, care must also be given to minimize load capacitance.

For wideband positive unity gain applications, the HA-2542 can also be over-compensated with capacitance greater than 30pF to achieve bandwidths of around 25MHz. This over-compensation will also improve capacitive load handling or lower the noise bandwidth. This versatility along with the ±100mA output current makes the HA-2542 an excellent high speed driver for many power applications.

## Typical Applications

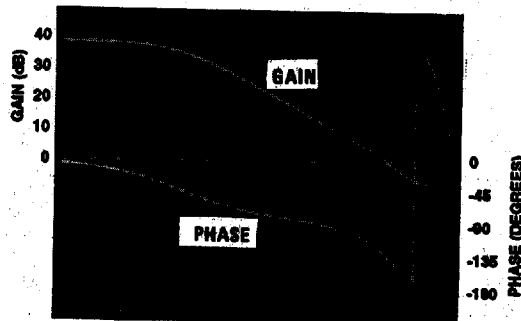
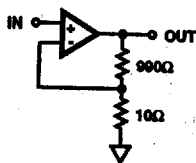

FREQUENCY (0dB) = 44.9MHz, PHASE MARGIN (0dB) = 40°  
 $A_{VCL} = 100$  PHASE AND GAIN

FIGURE 17. NONINVERTING CIRCUIT ( $A_{VCL} = 100$ )

Typical Applications (Continued)

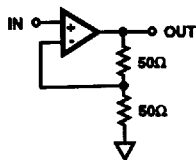

FREQUENCY (dB) = 56MHz, PHASE MARGIN (3dB) = 40°  
A<sub>VCL</sub> = 2 PHASE AND GAIN

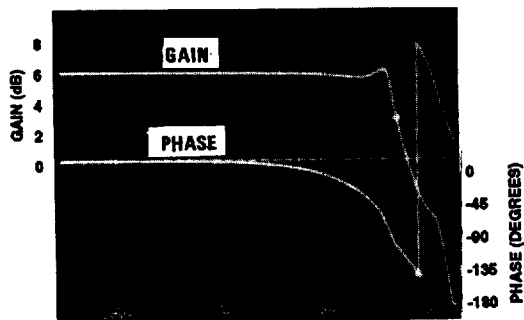
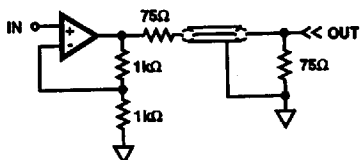

FIGURE 18. NONINVERTING CIRCUIT (A<sub>VCL</sub> = 2)



VIDEO CABLE DRIVER PULSE RESPONSE (1V/DIV.; 100ns/DIV.)

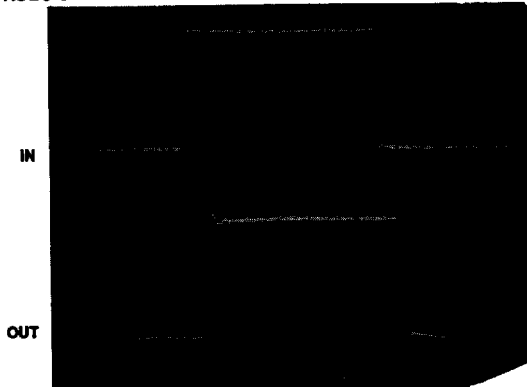
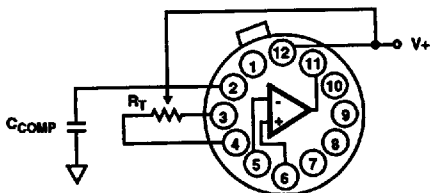

FIGURE 19. VIDEO CABLE DRIVER (A<sub>VCL</sub> = 2)



Suggested compensation scheme 5pF - 20pF.  
Tested Offset Adjustment Range is  $I_{V_{OS}} + 1mV$   
minimum referred to output.  
Typical range is  $\pm 20mV$  with  $R_T = 5k\Omega$ .

FIGURE 20. SUGGESTED OFFSET VOLTAGE ADJUSTMENT AND FREQUENCY COMPENSATION

2  
OPERATIONAL  
AMPLIFIERS