

LOC	DIST	REVISIONS					
GP	00	P	LYR	DESCRIPTION	DATE	OWN	APVD
		B		ECR-21-122345	23NOV2022	TL	HL

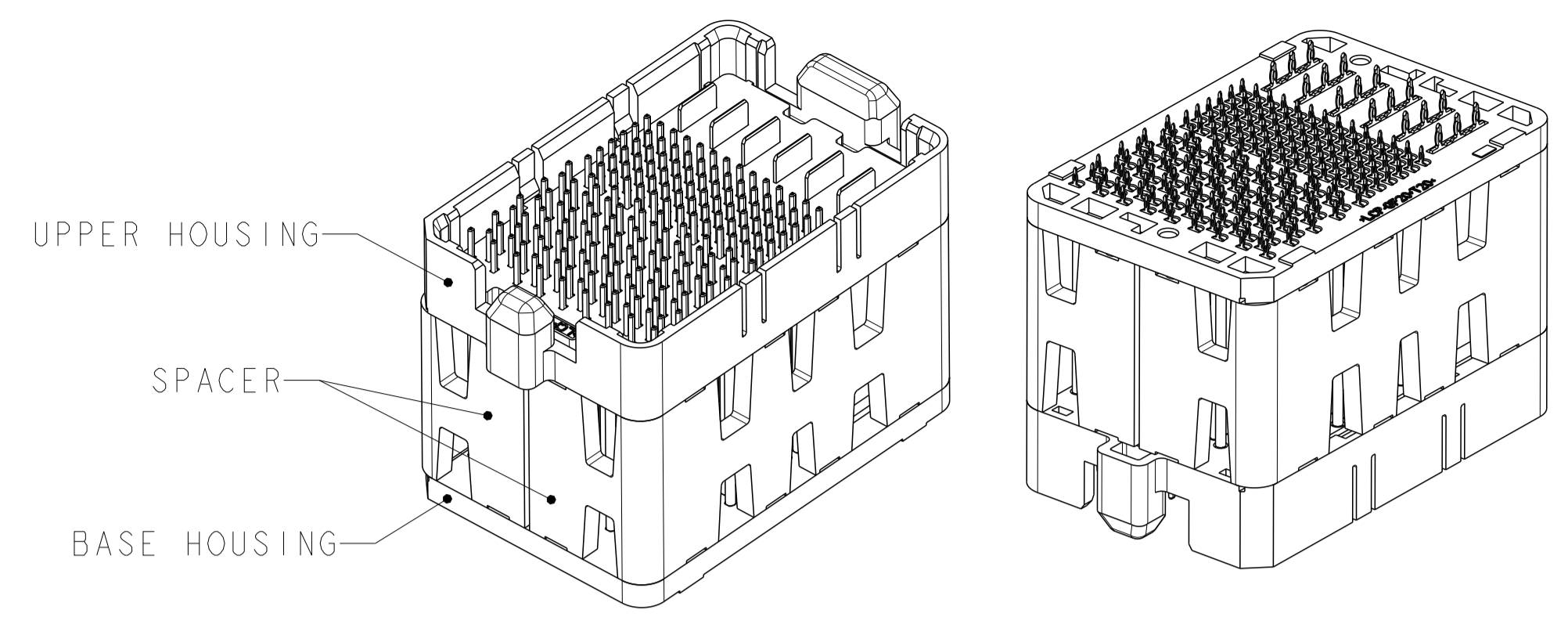

ISOMETRIC VIEW  
TYPICAL CONFIGURATION FOR 14mm THRU 42mm  
28mm SHOWN  
SCALE 2:1

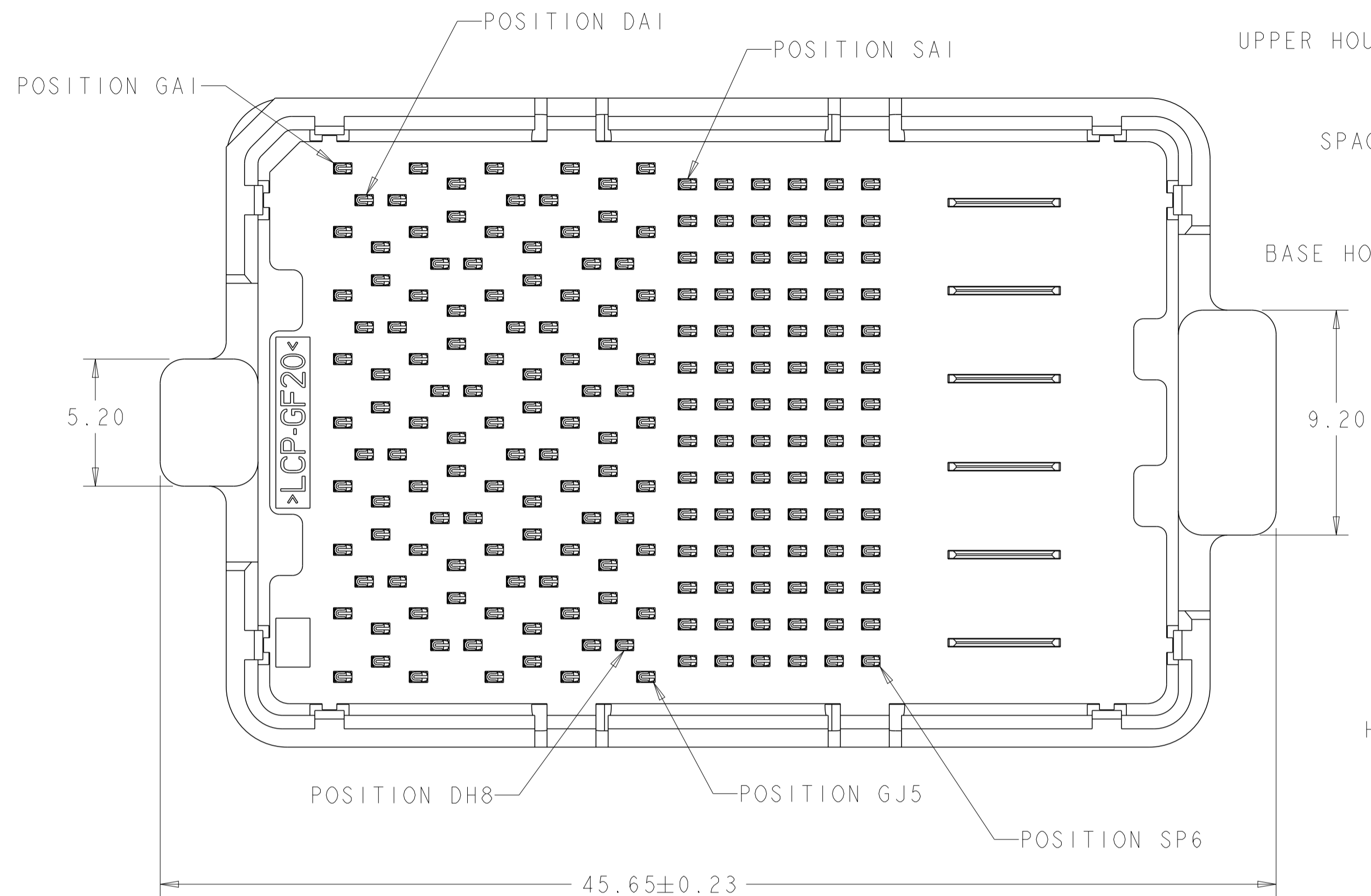
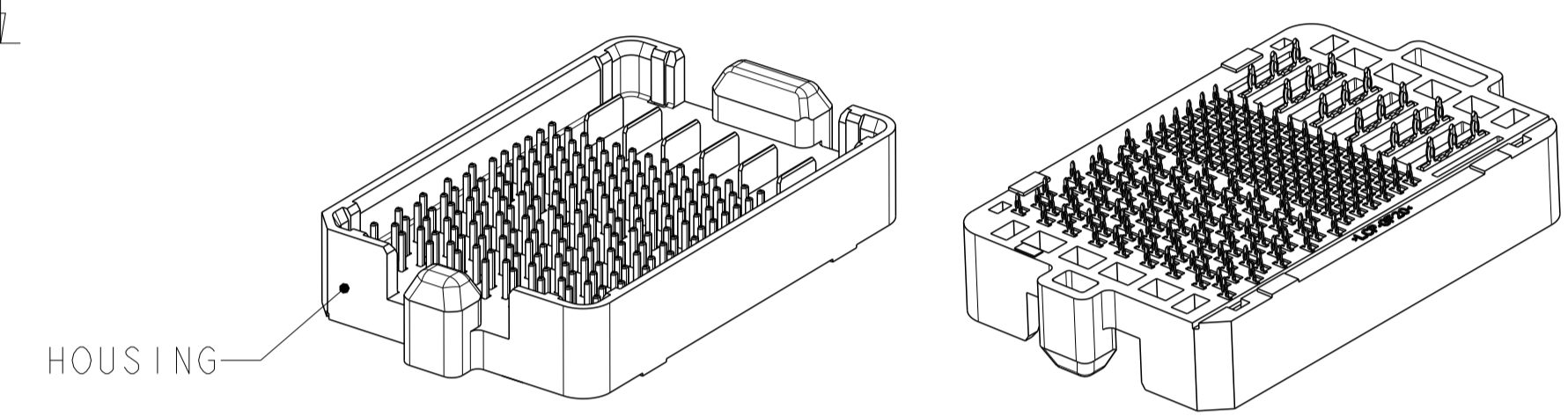

ISOMETRIC VIEW  
TYPICAL CONFIGURATION FOR 8mm THRU 13mm  
8mm SHOWN  
SCALE 2:1

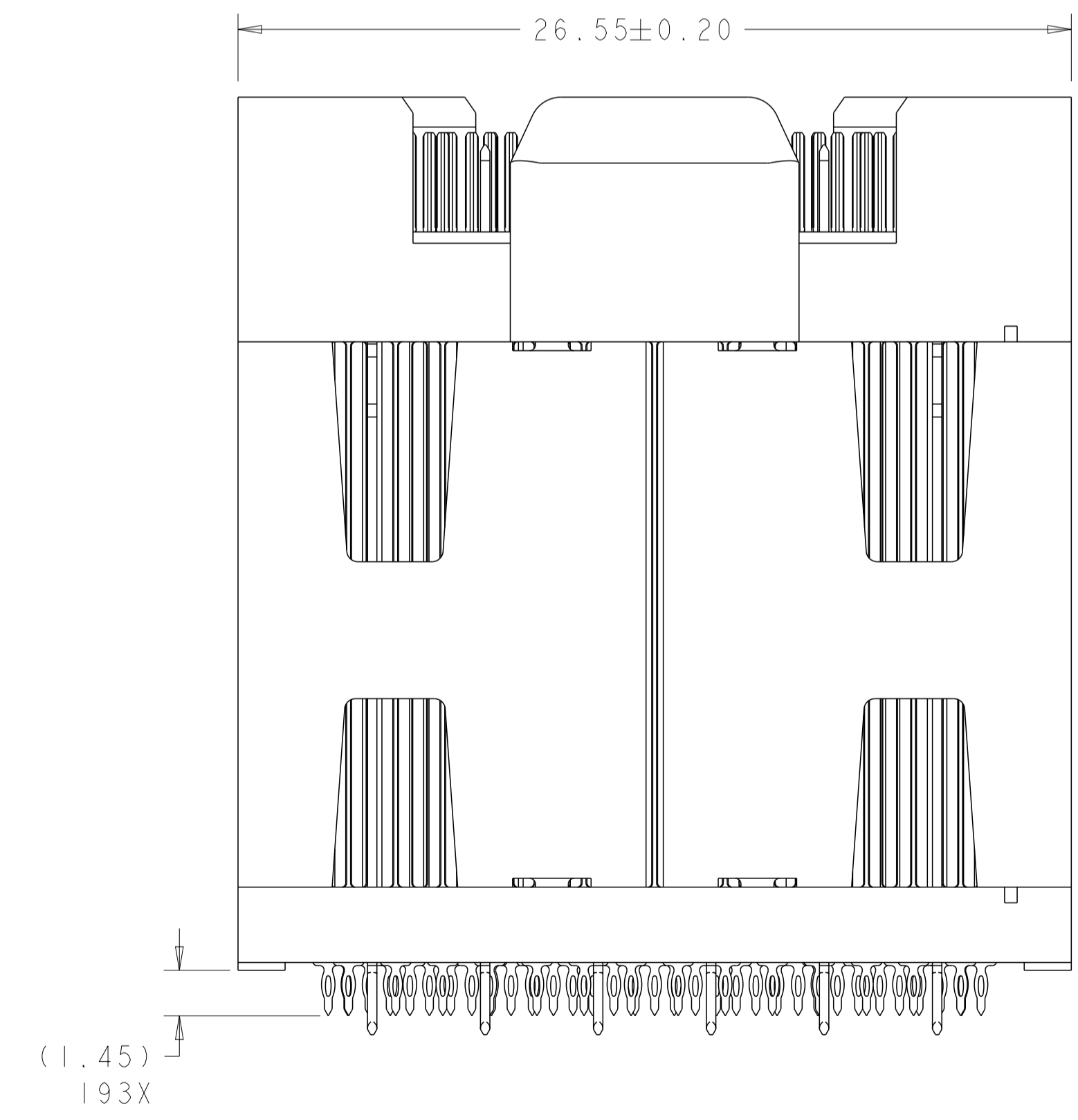
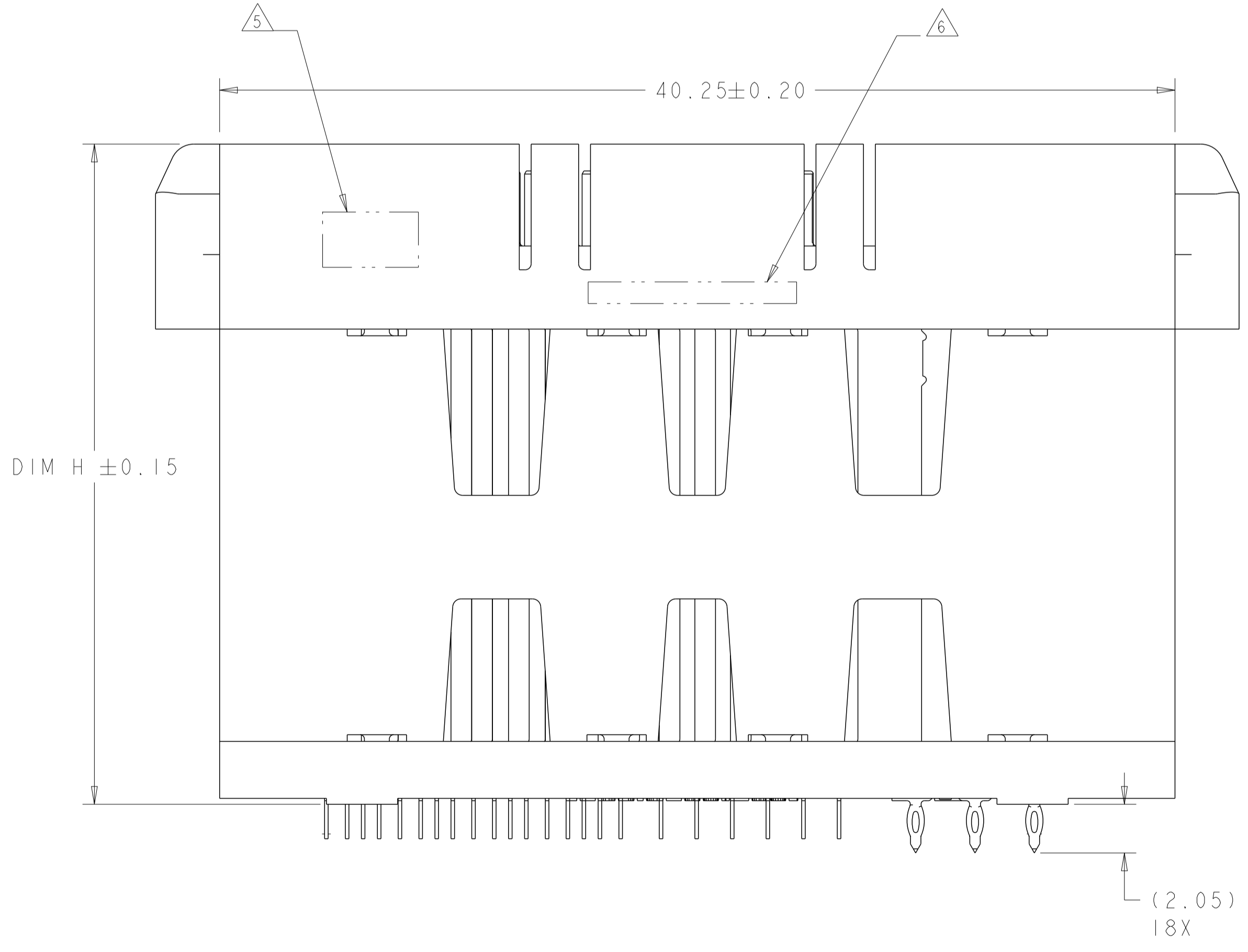

- 1 MATERIAL:  
BASE HOUSING, UPPER HOUSING, ORGANIZER,  
AND SPACER: THERMOPLASTIC, FLAMMABILITY  
RATING UL94-V0  
CONTACT: COPPER ALLOY
- 2. CONFORMS TO THE REQUIREMENTS OF TE PRODUCT  
SPECIFICATION, 108-2375; BASED ON TELCORDIA  
GR-1217-CORE FOR SYSTEM QUALITY LEVEL III,  
APPLICATIONS IN CONTROLLED ENVIRONMENTS  
(CENTRAL OFFICE).  
SEE TE PRODUCT SPECIFICATION 108-2375 FOR  
TEST SEQUENCES.
- 3 ROWS GA THRU GJ (SHOWN DARKENED) ARE TYPICALLY  
USED AS GROUNDS.
- 4 SPECIFIED POSITIONAL TOLERANCE DEFINES HOLE TO  
HOLE LOCATION WITHIN HOLE PATTERN. POSITIONAL  
TOLERANCE OF HOLE PATTERN TO FIDUCIAL MARKS  
OR PCB DATUMS SHALL BE DEFINED BY CUSTOMER.
- 5 AREA RESERVED FOR TE CONNECTIVITY LOGO.
- 6 AREA RESERVED FOR PART NUMBER (X-XXXXXXX-X)  
AND DATE CODE (YYWW).
- 7 USE CENTERLINES INDICATED ON PCB HOLE PATTERN  
TO ESTABLISH ALIGNMENT BETWEEN HEADER AND  
RECEPTACLE BOARDS.
- 8 PLATED THROUGH HOLE REQUIREMENTS - SIGNAL:  
HOLE SIZE PRIOR TO PLATING =  $\varnothing 0.420 \pm 0.013$   
COPPER PLATING THICKNESS =  $0.038 \pm 0.013$   
CALCULATED FINISHED HOLE SIZE =  $\varnothing 0.344 \pm 0.039$   
THESE DIMENSIONS APPLY TO THE TOP 1.25mm OF  
THE PCB THICKNESS FROM THE CONNECTOR MOUNTING  
SIDE.
- 9 PLATED THROUGH HOLE REQUIREMENTS - POWER:  
HOLE SIZE PRIOR TO PLATING =  $\varnothing 0.700 \pm 0.025$   
COPPER PLATING THICKNESS =  $0.038 \pm 0.013$   
CALCULATED FINISHED HOLE SIZE =  $\varnothing 0.624 \pm 0.051$   
THESE DIMENSIONS APPLY TO THE TOP 1.50mm OF  
THE PCB THICKNESS FROM THE CONNECTOR MOUNTING  
SIDE.
- 10 CONTACT SALES FOR AVAILABILITY OF THIS STACK  
HEIGHT.

**SIZE 2 HOUSING W/ GUIDE POSTS \***  
**32 DIFFERENTIAL PAIRS**  
**84 HIGH-DENSITY GRID**  
**193 TOTAL SIGNAL CONTACTS**  
**6 POWER CONTACTS**

\* SIZE 1 AND SIZE 3 ARE ALSO AVAILABLE

THIS DRAWING IS A CONTROLLED DOCUMENT.		OWN: D. RINGLER 05SEP2008	TE Connectivity
DIMENSIONS: mm		CHK: D. TROUT 05SEP2008	
TOLERANCES UNLESS OTHERWISE SPECIFIED:		APVD: J. FEEDER 05SEP2008	NAME: HEADER ASSEMBLY
0 PLC ±	1 PLC ±0.13	PRODUCT SPEC: 108-2375	32/84/6P
2 PLC ±0.13	3 PLC ±0.013	APPLICATION SPEC: 114-13249	STRADA MESA MEZZANINE CONNECTOR
4 PLC ±	ANGLES ±1	FINISH	SIZE: A1
MATERIAL: △		WEIGHT	CAGE CODE: 00779
			DRAWING NO: 2057470
		Customer Drawing	RESTRICTED TO: -
		SCALE: 2:1	SHEET 1 OF 4
			REV B

THIS DRAWING IS UNPUBLISHED. RELEASED FOR PUBLICATION 20  
 © COPYRIGHT 20 BY - ALL RIGHTS RESERVED.

LOC	DIST	REVISIONS					
GP	00	P	LYN	DESCRIPTION	DATE	OWN	APVD
		-		SEE SHEET 1			

	41.8	42mm	MATTE Sn	9-2057470-2
	40.8	41mm	MATTE Sn	9-2057470-1
YES	39.8	40mm	MATTE Sn	9-2057470-0
	38.8	39mm	MATTE Sn	8-2057470-9
	37.8	38mm	MATTE Sn	8-2057470-8
	36.8	37mm	MATTE Sn	8-2057470-7
	35.8	36mm	MATTE Sn	8-2057470-6
	34.8	35mm	MATTE Sn	8-2057470-5
	33.8	34mm	MATTE Sn	8-2057470-4
	32.8	33mm	MATTE Sn	8-2057470-3
	31.8	32mm	MATTE Sn	8-2057470-2
	30.8	31mm	MATTE Sn	8-2057470-1
	29.8	30mm	MATTE Sn	8-2057470-0
	28.8	29mm	MATTE Sn	7-2057470-9
YES	27.8	28mm	MATTE Sn	7-2057470-8
	26.8	27mm	MATTE Sn	7-2057470-7
	25.8	26mm	MATTE Sn	7-2057470-6
	24.8	25mm	MATTE Sn	7-2057470-5
	23.8	24mm	MATTE Sn	7-2057470-4
YES	22.8	23mm	MATTE Sn	7-2057470-3
	21.8	22mm	MATTE Sn	7-2057470-2
	20.8	21mm	MATTE Sn	7-2057470-1
	19.8	20mm	MATTE Sn	7-2057470-0
	18.8	19mm	MATTE Sn	6-2057470-9
	17.8	18mm	MATTE Sn	6-2057470-8
	16.8	17mm	MATTE Sn	6-2057470-7
	15.8	16mm	MATTE Sn	6-2057470-6
	14.8	15mm	MATTE Sn	6-2057470-5
	13.8	14mm	MATTE Sn	6-2057470-4
	12.8	13mm	MATTE Sn	6-2057470-3
	11.8	12mm	MATTE Sn	6-2057470-2
YES	10.8	11mm	MATTE Sn	6-2057470-1
	9.8	10mm	MATTE Sn	6-2057470-0
	8.8	9mm	MATTE Sn	5-2057470-9
	7.8	8mm	MATTE Sn	5-2057470-8
TOOLED	DIM H	STACK HEIGHT	CONTACT TAIL PLATING	PART NUMBER

<del></del>	<del>41.8</del>	<del>42mm</del>	<del>Sn/Pb</del>	<del>4-2057470-2</del>
<del></del>	<del>40.8</del>	<del>41mm</del>	<del>Sn/Pb</del>	<del>4-2057470-1</del>
<del>YES</del>	<del>39.8</del>	<del>40mm</del>	<del>Sn/Pb</del>	<del>4-2057470-0</del>
<del></del>	<del>38.8</del>	<del>39mm</del>	<del>Sn/Pb</del>	<del>3-2057470-9</del>
<del></del>	<del>37.8</del>	<del>38mm</del>	<del>Sn/Pb</del>	<del>3-2057470-8</del>
<del></del>	<del>36.8</del>	<del>37mm</del>	<del>Sn/Pb</del>	<del>3-2057470-7</del>
<del></del>	<del>35.8</del>	<del>36mm</del>	<del>Sn/Pb</del>	<del>3-2057470-6</del>
<del></del>	<del>34.8</del>	<del>35mm</del>	<del>Sn/Pb</del>	<del>3-2057470-5</del>
<del></del>	<del>33.8</del>	<del>34mm</del>	<del>Sn/Pb</del>	<del>3-2057470-4</del>
<del></del>	<del>32.8</del>	<del>33mm</del>	<del>Sn/Pb</del>	<del>3-2057470-3</del>
<del></del>	<del>31.8</del>	<del>32mm</del>	<del>Sn/Pb</del>	<del>3-2057470-2</del>
<del></del>	<del>30.8</del>	<del>31mm</del>	<del>Sn/Pb</del>	<del>3-2057470-1</del>
<del></del>	<del>29.8</del>	<del>30mm</del>	<del>Sn/Pb</del>	<del>3-2057470-0</del>
<del></del>	<del>28.8</del>	<del>29mm</del>	<del>Sn/Pb</del>	<del>2-2057470-9</del>
<del>YES</del>	<del>27.8</del>	<del>28mm</del>	<del>Sn/Pb</del>	<del>2-2057470-8</del>
<del></del>	<del>26.8</del>	<del>27mm</del>	<del>Sn/Pb</del>	<del>2-2057470-7</del>
<del></del>	<del>25.8</del>	<del>26mm</del>	<del>Sn/Pb</del>	<del>2-2057470-6</del>
<del></del>	<del>24.8</del>	<del>25mm</del>	<del>Sn/Pb</del>	<del>2-2057470-5</del>
<del></del>	<del>23.8</del>	<del>24mm</del>	<del>Sn/Pb</del>	<del>2-2057470-4</del>
<del>YES</del>	<del>22.8</del>	<del>23mm</del>	<del>Sn/Pb</del>	<del>2-2057470-3</del>
<del></del>	<del>21.8</del>	<del>22mm</del>	<del>Sn/Pb</del>	<del>2-2057470-2</del>
<del></del>	<del>20.8</del>	<del>21mm</del>	<del>Sn/Pb</del>	<del>2-2057470-1</del>
<del></del>	<del>19.8</del>	<del>20mm</del>	<del>Sn/Pb</del>	<del>2-2057470-0</del>
<del></del>	<del>18.8</del>	<del>19mm</del>	<del>Sn/Pb</del>	<del>1-2057470-9</del>
<del></del>	<del>17.8</del>	<del>18mm</del>	<del>Sn/Pb</del>	<del>1-2057470-8</del>
<del></del>	<del>16.8</del>	<del>17mm</del>	<del>Sn/Pb</del>	<del>1-2057470-7</del>
<del></del>	<del>15.8</del>	<del>16mm</del>	<del>Sn/Pb</del>	<del>1-2057470-6</del>
<del></del>	<del>14.8</del>	<del>15mm</del>	<del>Sn/Pb</del>	<del>1-2057470-5</del>
<del></del>	<del>13.8</del>	<del>14mm</del>	<del>Sn/Pb</del>	<del>1-2057470-4</del>
<del></del>	<del>12.8</del>	<del>13mm</del>	<del>Sn/Pb</del>	<del>1-2057470-3</del>
<del></del>	<del>11.8</del>	<del>12mm</del>	<del>Sn/Pb</del>	<del>1-2057470-2</del>
<del>YES</del>	<del>10.8</del>	<del>11mm</del>	<del>Sn/Pb</del>	<del>1-2057470-1</del>
<del></del>	<del>9.8</del>	<del>10mm</del>	<del>Sn/Pb</del>	<del>1-2057470-0</del>
<del></del>	<del>8.8</del>	<del>9mm</del>	<del>Sn/Pb</del>	<del>2057470-9</del>
<del></del>	<del>7.8</del>	<del>8mm</del>	<del>Sn/Pb</del>	<del>2057470-8</del>
TOOLED	DIM H	STACK HEIGHT	CONTACT TAIL PLATING	PART NUMBER

THIS DRAWING IS A CONTROLLED DOCUMENT. DIMENSIONS: mm. TOLERANCES UNLESS OTHERWISE SPECIFIED: 0 PLC ±. 1 PLC ±0.13. 2 PLC ±0.13. 3 PLC ±0.13. 4 PLC ±. ANGLES ±. FINISH.

CHK: D. RINGLER 05SEP2008. D. TROUT 05SEP2008. APVD: J. FEEDER 05SEP2008.

NAME: HEADER ASSEMBLY 32/84/6P STRADA MESA MEZZANINE CONNECTOR. SIZE: A1. CAGE CODE: 114-13249. DRAWING NO: 100779. ©=2057470. WEIGHT: -. RESTRICTED TO: Customer Drawing. SCALE: 6:1. SHEET: 2 OF 4. REV: B.

**STE** TE Connectivity

LOC	DIST	REVISIONS			
P	LTN	DESCRIPTION	DATE	OWN	APVD
-	-	SEE SHEET 1	-	-	-

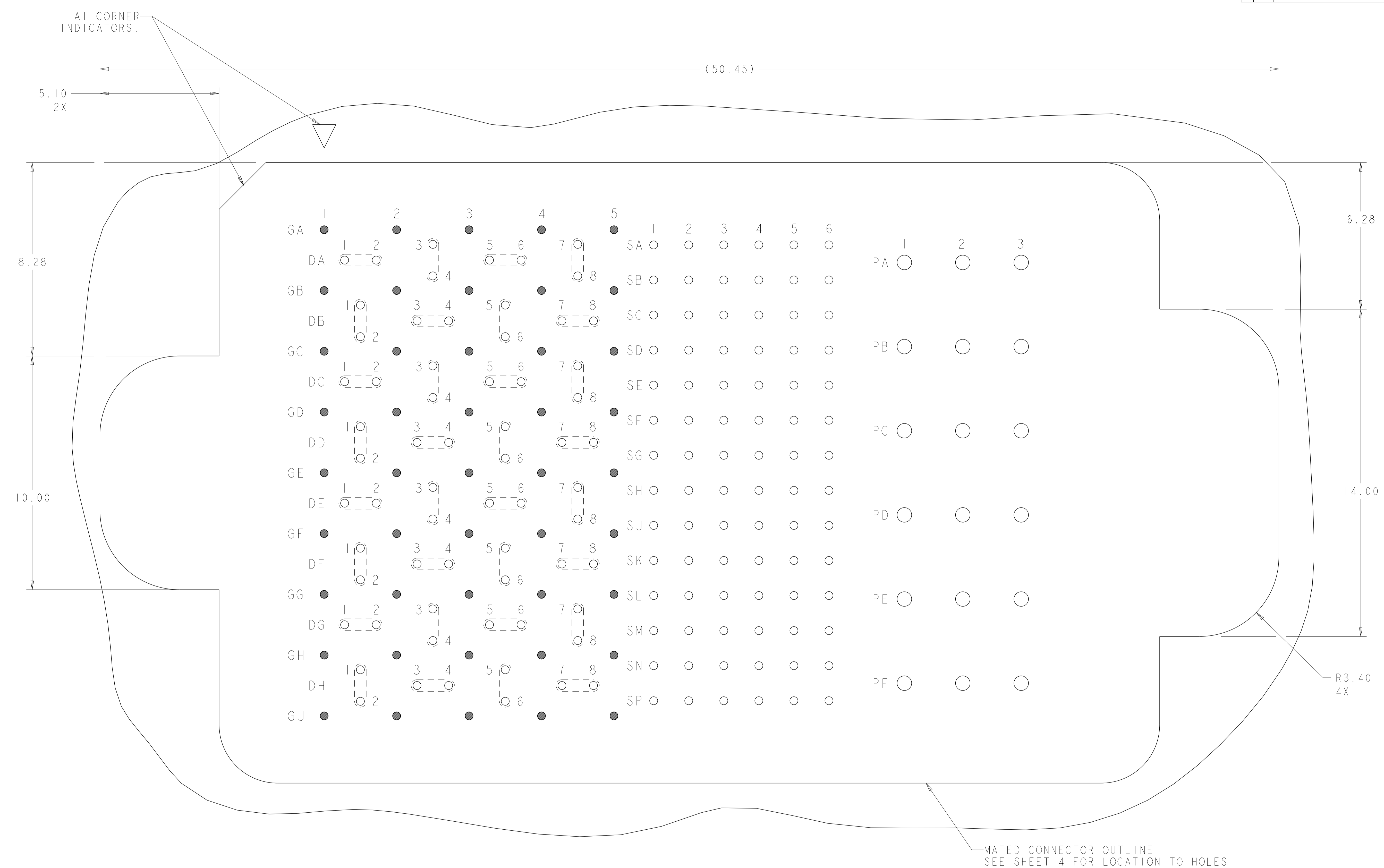

**PCB LAYOUT AND PIN IDENTIFICATION**   
 SHOWN FROM CONNECTOR SIDE  
 SCALE 12:1

THIS DRAWING IS A CONTROLLED DOCUMENT.		OWN D. RINGLER 05SEP2008	TE Connectivity
DIMENSIONS:		CHK D. TROUT 05SEP2008	
mm	TOLERANCES UNLESS OTHERWISE SPECIFIED:	APVD J. FEEDER 05SEP2008	NAME HEADER ASSEMBLY 32/84/6P
0 PLC ±	1 PLC ±0.13	PRODUCT SPEC	108-2375
2 PLC ±0.013	3 PLC ±0.013	APPLICATION SPEC	114-13249
4 PLC ±	ANGLES ±1	FINISH	114-13249
MATERIAL		WEIGHT	A100779C=2057470
		Customer Drawing	SCALE 6:1 SHEET 3 OF 4 REV B

LOC		DIST		REVISIONS				
GP	00	P	LYR	DESCRIPTION	DATE	OWN	APVD	
		-		SEE SHEET 1				

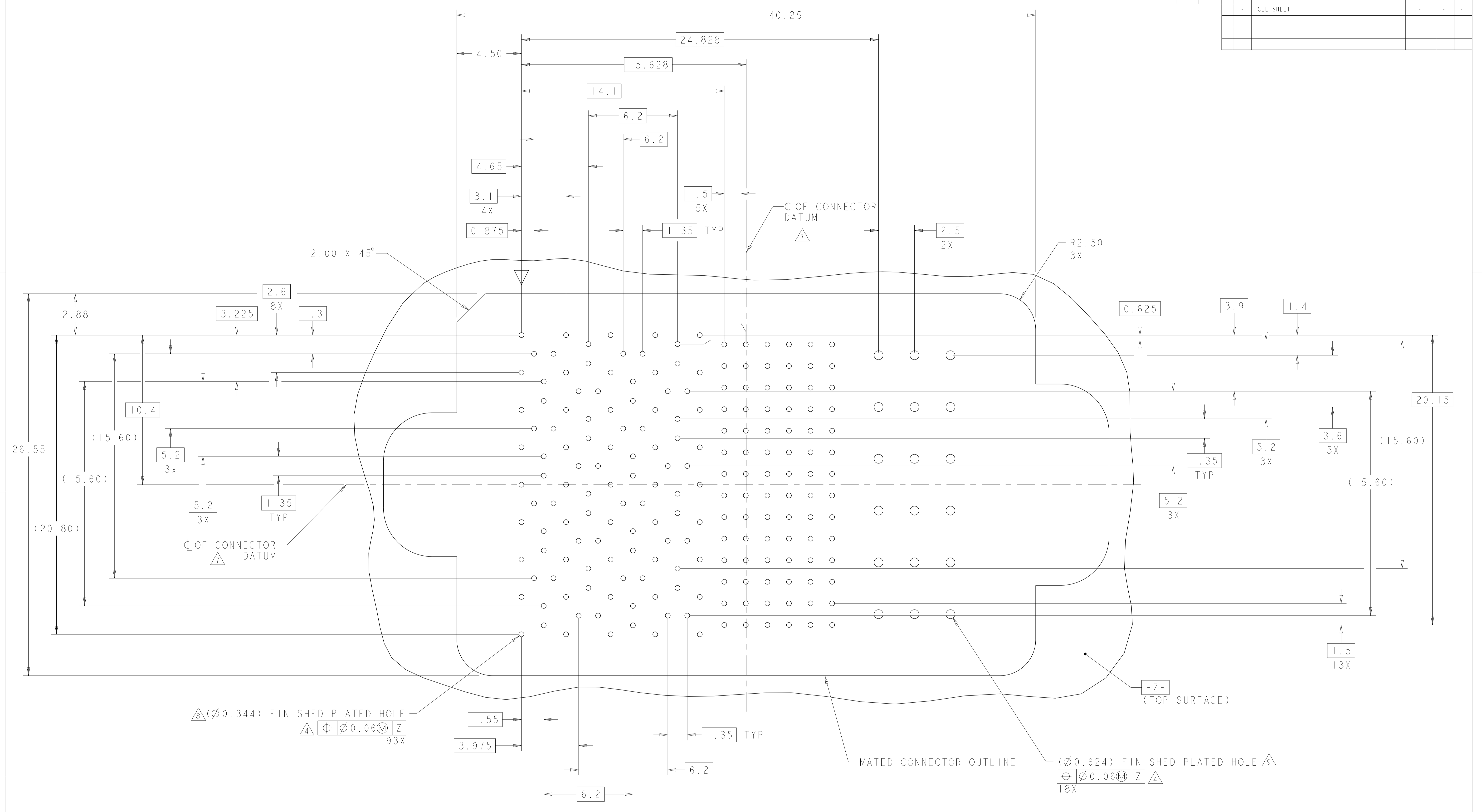

**PCB HOLE PATTERN**  
 SHOWN FROM CONNECTOR SIDE  
 SCALE 8:1

THIS DRAWING IS A CONTROLLED DOCUMENT.		OWN D. RINGLER 05SEP2008	 TE Connectivity
DIMENSIONS:		CHK D. TROUT 05SEP2008	
TOLERANCES UNLESS OTHERWISE SPECIFIED:		APVD J. FEEDER 05SEP2008	
0 PLC ± 1 PLC ± 2 PLC ±0.13 3 PLC ±0.013 4 PLC ± ANGLES ±1 FINISH		NAME HEADER ASSEMBLY 32/84/6P STRADA MESA MEZZANINE CONNECTOR	
MATERIAL		PRODUCT SPEC 108-2375	SIZE A100779C=2057470
WEIGHT		APPLICATION SPEC 114-13249	RESTRICTED TO
Customer Drawing		SCALE 6:1	SHEET 4 OF 4 REV B