

PART NUMBER	REVISION	DESCRIPTION	FEED TYPE
2151411-2	L	FINE CRIMP HEIGHT ADJUST	PNEUMATIC
7-2151411-2	L	PNEUMATIC AND CRIMP TOOLING KIT	PNEUMATIC
7-2151411-7	E	CRIMP TOOLING KIT	-

ATLANTIC VERSION TERMINATOR INTERFACE ADAPTER

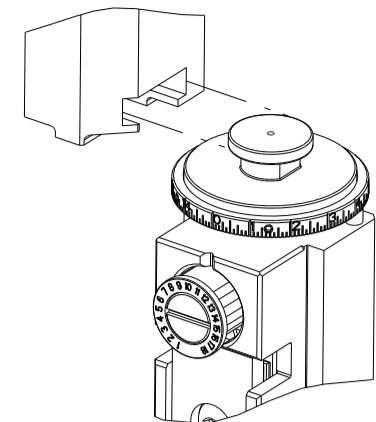

APPLICATOR DATA		
CRIMP	SIZE	TYPE
WIRE	5.33 mm [.210]	F
INSUL	5.59 mm [.220]	O

APPLICATOR INSTRUCTIONS
408-35042

TERMINAL DATA: TE TERMINAL		TE CRIMP SPECIFICATION	
TERMINAL NAME: MALE TYPE XII CONTACT ASSEMBLY			
WIRE STRIP LENGTH		INSULATION DIAMETER RANGE	
7.54-9.12 mm [.297-.359 IN]		Ø 4.83-5.59 mm [.190-.220 IN]	
TERMINAL APPLICATION SPECIFICATION	114-10005		
TERMINALS APPLIED			
TE TERMINAL	TE TERMINAL	TE TERMINAL	TE TERMINAL
66253-5	66253-6	66253-8	1-66253-0
66741-9	1-66741-1	1-66741-2	2-66741-0
172738-2	172738-3	1-172738-1	1-172738-2
66254-5			

WIRE SIZE	CRIMP HEIGHT mm [INCH]	CRIMP HEIGHT REFERENCE SETTING
10 AWG	2.82 +/- 0.10 [.111 +/- .004]	8.4

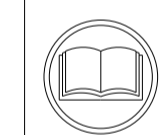

- RECOMMENDED SPARE PARTS
- REFER TO SUPPLIED INSTRUCTION SHEET FOR CLEANING, LUBRICATION AND STORAGE OF APPLICATOR.
- APPLY PART NUMBER 2-23419-6 LOCTITE TO THREADS OF ITEM 242.
- CRIMP HEIGHT REFERENCE SETTING WAS THE SETTING USED WHEN THE APPLICATOR WAS QUALIFIED AT THE FACTORY. ADJUSTMENT MAY BE NECESSARY WHEN RUNNING APPLICATOR IN THE FIELD.
- TERMINAL PITCH NOT COMPATIBLE WITH MECHANICAL FEED.
- MARKING FROM WIRE CRIMPER IN TRANSITION AREA BETWEEN WIRE BARREL AND RECEPTACLE IS NECESSARY TO MAINTAIN GAP OF RECEPTACLE.
- 7. UNLESS SPECIFIED OTHERWISE TORQUE VALUES SHALL BE USED PER DOCUMENT, 101-35000.
- TERMINAL LUBRICANT IS RECOMMENDED.

***WARNING**
ON INSTALLATION, SET WIRE DISC TO CRIMP HEIGHT REFERENCE SETTING FOR LARGEST WIRE SIZE. CRIMP HEIGHT REFERENCE SETTINGS GREATER THAN THE VALUE SHOWN MAY CAUSE DAMAGE TO THE CRIMP TOOLING, REFER TO THE INSTRUCTION SHEET FOR PROPER SETUP AND ADJUSTMENTS.

ATLANTIC VERSION
Shown on sheets 1 of 4 & 2 of 4
(Pacific version shown on sheets 3 of 4 & 4 of 4)

LOC	DIST	REVISIONS					
A	66	P	LTN	DESCRIPTION	DATE	OWN	APVD
		J1		ECR-20-003835	13MAR2020	FZ	RK
		K		ECR-20-007866	02JUN2020	FJ	TE
		K1		ECR-21-006777	08JUL2021	FJ	RK
		L		ECR-22-149587	17AUG2022	FJ	TE

-	1	1	2119641-1	FEED CAM, AIR FEED	248
-	1	1	2119082-8	CAM, SNAIL, INSULATION ADJUSTMENT	244
-	1	1	2079764-1	WASHER, WAVE SPRING, CREST-TO-CREST	243
-	1	1	2119083-1	RETAINER, INSULATION DIAL	242
-	1	1	7-18023-7	SCR, SKT HD CAP M3 X 4.0	241
-	1	1	2844940-2	AIR FEED MODULE	238
-	REF	REF	994970-2	COUNTER, MAGNETIC	164
-	1	1	1-18028-2	WASHER, FLAT, REG M4	119
-	1	1	2119955-1	ASSY, LUBRICATOR, SIDE FEED	113
-	1	1	2844908-1	SCREW, LOCKING	99
-	1	1	2844907-1	POST, LOCKING	98
-	1	1	1-690438-0	FRONT STRIP GUIDE	96
-	1	1	1803078-2	SPACER, PRECISION	83
-	1	1	1-455888-2	SPACER, CRIMPER	82
-	2	2	1-2079383-8	SCR, BHSC, RoHS (M4 X 6)	79
-	1	1	1803096-1	EXTENSION PLATE	78
-	1	1	1803607-3	DOCUMENTATION PACKAGE	71
-	1	1	2119791-9	DEPRESSOR, WIRE	70
-	1	1	2119740-1	TAG, IDENTIFICATION	67
-	2	2	2168078-1	SCREW, DRIVE, RH, RoHS, 2 x .188	66
-	1	1	2168083-2	SCR, SKT HD CAP, RoHS, M4 X 8.0	60
-	1	1	5-18022-5	SCR, HEX HD CAP, M4 X 6.0	59
-	1	1	2168083-3	SCR, SKT HD CAP, RoHS, M4 X 12.0	57
-	1	1	1-1338683-1	FEED PAWL	56
-	4	4	2168083-3	SCR, SKT HD CAP, RoHS, M4 X 12.0	54
-	1	1	5018030-1	NUT, HEX, REG, RoHS, M3	52
-	1	1	811242-6	BUMPER, HOLD DOWN	51
-	1	1	690753-2	SPACER, TONKER	50
-	1	1	18023-9	SCR, SKT HD CAP M4 X 6.0	49
-	1	1	1803583-9	APPLICATOR BASIC ASSEMBLY, SF	46
-	1	1	1803515-2	RAM ASSEMBLY, SF ATLANTIC	44
-	1	1	1803602-2	SCR, BHSC, RoHS (M8 X 40)	41
-	1	1	3-1752356-3	SUPPORT, TERMINAL	34
-	2	2	2079383-5	SCR, BHSC, RoHS (M4 X 20)	33
-	2	2	2-2844962-6	SPACER, CYLINDRICAL, STRIP GUIDE	30
-	1	1	2844992-5	ASSEMBLY, STRIP GUIDE	29
-	2	2	22283-1	SPRING, COMPRESSION	27
-	1	1	240792-1	DRAG, TERMINAL	25
-	1	1	2-1320928-4	STRIP GUIDE	24
-	1	1	2168083-2	SCR, SKT HD CAP, RoHS, M4 X 8.0	21
-	1	1	1-18028-2	WASHER, FLAT, REG M4	20
-	1	1	2119533-1	STRIPPER, SIDE FEED	19
-	1	1	2119806-1	INSERT, SHEAR	13
-	1	1	5-22280-0	SPRING, COMPRESSION	12
-	1	1	1-356885-4	STOP, SHEAR	11
-	1	1	2-2119805-1	SHEAR HOLDER, FRONT	10
-	1	1	454276-5	FLOATING SHEAR, FRONT	9
-	1	2	1333211-6	ANVIL, COMBINATION .150-.300	8
-	1	1	5-240641-9	SPACER	7
-	-	-	-	-	6
-	1	1	1-2119757-3	DEPRESSOR, SHEAR	5
-	1	1	238011-1	BLOCK, CRIMPER SPACER	4
-	1	2	7-1633966-6	CRIMPER, INSULATION O	3
-	1	1	455888-6	SPACER, CRIMPER	2
-	1	2	1-456430-5	CRIMPER, WIRE	1

DIMENSIONS:		TOLERANCES UNLESS OTHERWISE SPECIFIED:		MATERIAL:		FINISH:		WEIGHT:		SCALE:	
mm	0 PLC ±	1 PLC ±	2 PLC ±	3 PLC ±	4 PLC ±	ANGLES	FINISH			Customer Accessible Production Drawing	SCALE 1:2
											SHEET 1 OF 4

OWN: C. CHEN 15DEC2011
CHK: S. XI 15DEC2011
APVD: J. CRUZ 15DEC2011

NAME: Ocean Side Feed Applicator

SIZE: A1 CAGE CODE: 00779 DRAWING NO: 2151411

RESTRICTED TO: L

LOC	DIST	REVISIONS			
P	LTN	DESCRIPTION	DATE	OWN	APVD
A	66	SEE SHEET 1	-	-	-

FEED TYPE

PNEUMATIC

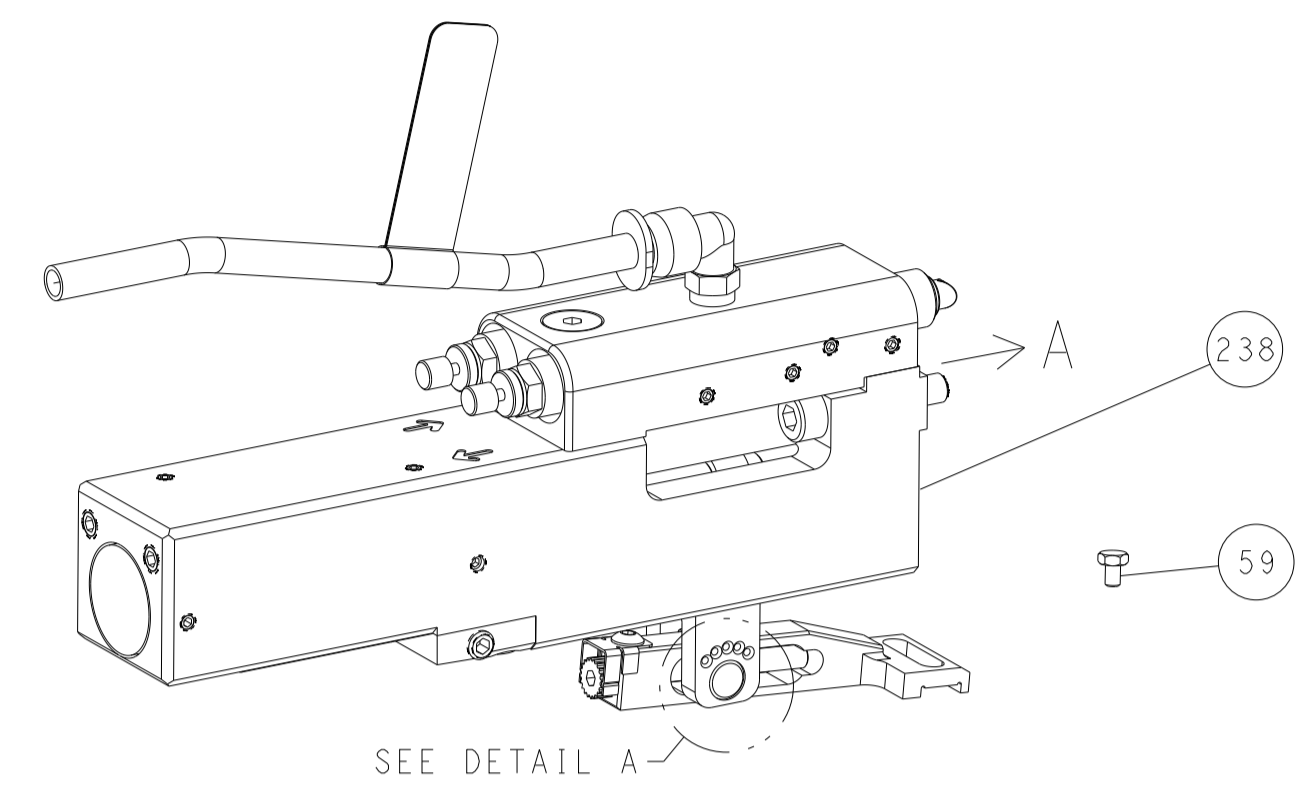

SEE DETAIL A

FEED SPRING SETTING POSITION
(SHOWN FROM REAR SIDE)

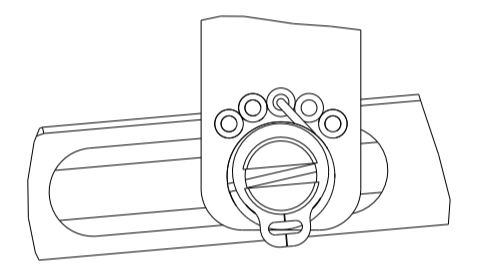

DETAIL A

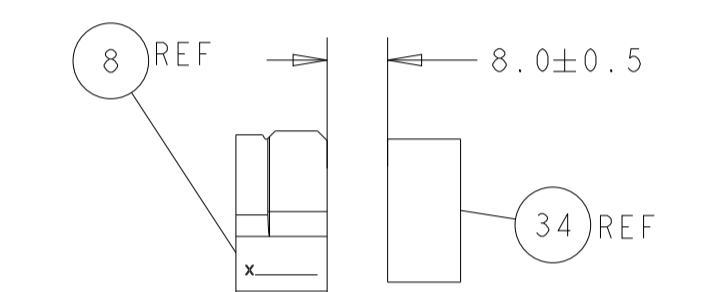
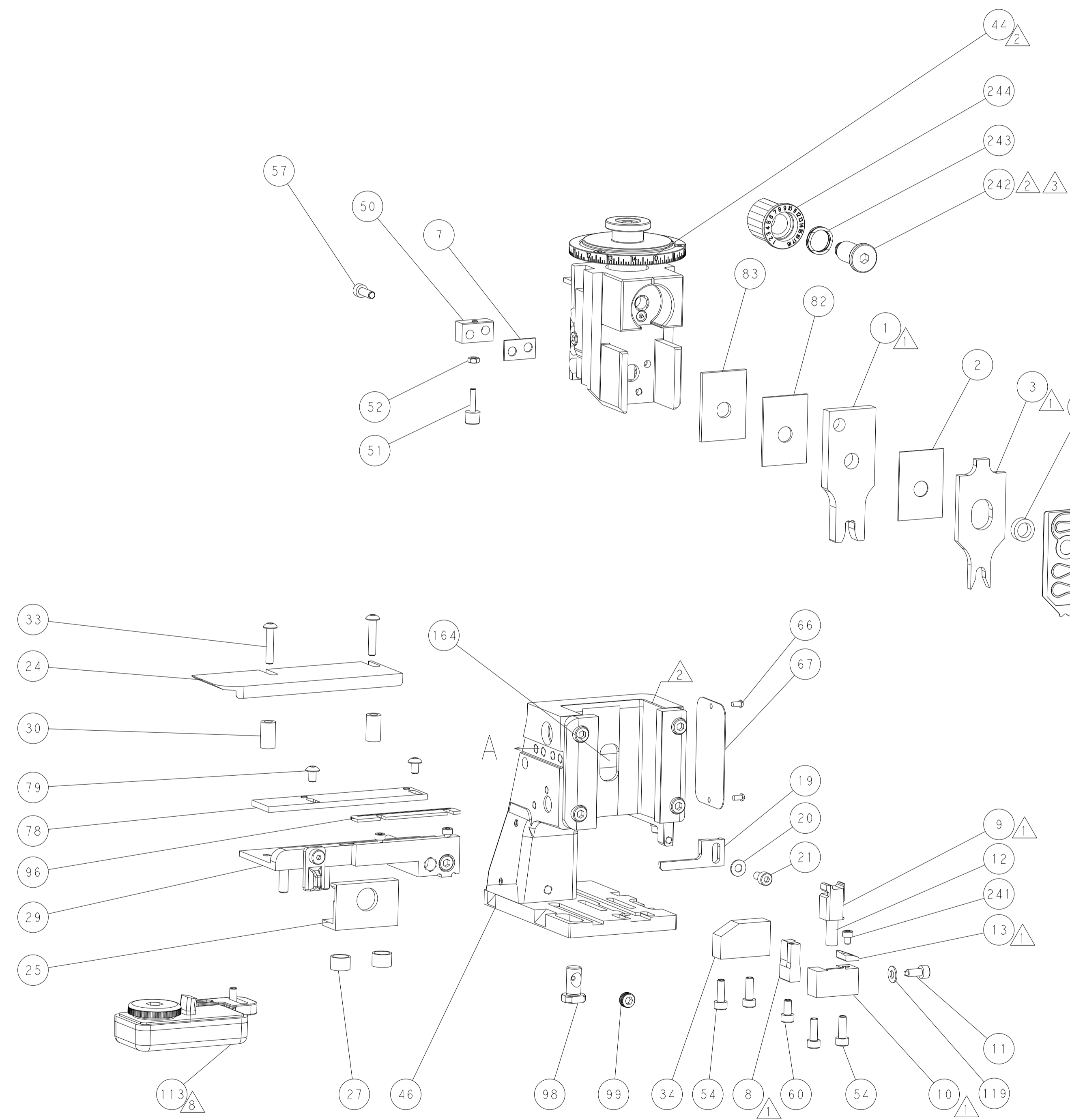

TERMINAL SUPPORT LOCATION

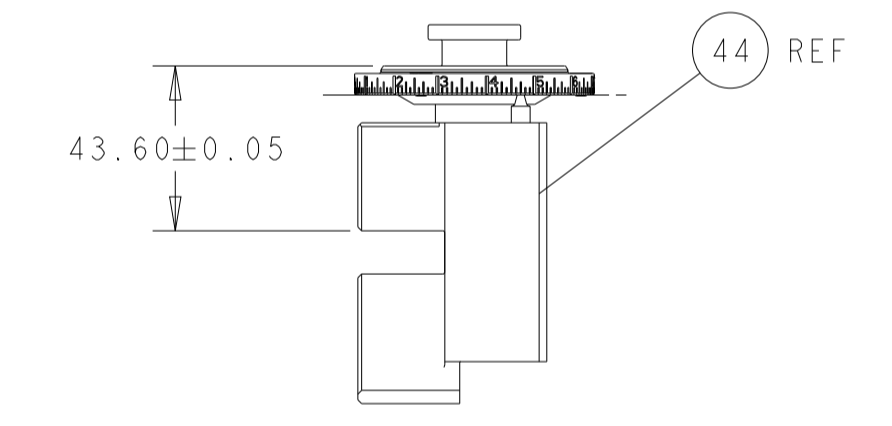

RAM SET-UP

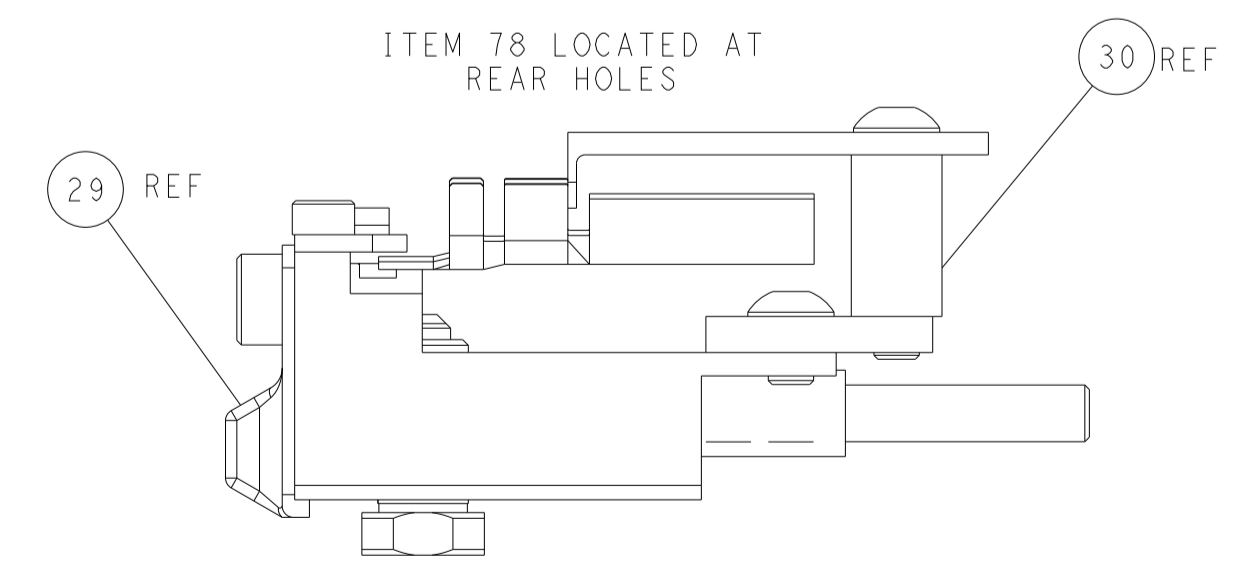

FEED TRACK POSITION
GUIDE BY WIRE BARREL

CAM POSITION

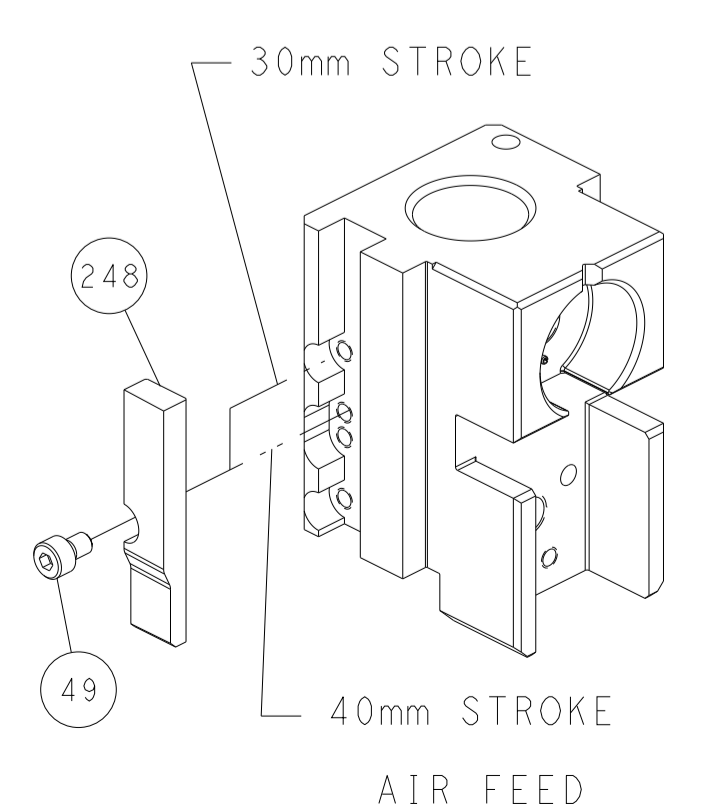

ATLANTIC VERSION
 Shown on sheets 1 of 4 & 2 of 4
 (Pacific version shown on sheets 3 of 4 & 4 of 4)

<small>THIS DRAWING IS UNPUBLISHED. RELEASED FOR PUBLICATION. ALL RIGHTS RESERVED. © 2000 BY TYCO ELECTRONICS CORPORATION. THIS DRAWING IS UNPUBLISHED. RELEASED FOR PUBLICATION. ALL RIGHTS RESERVED. © 2000 BY TYCO ELECTRONICS CORPORATION. THIS DRAWING IS UNPUBLISHED. RELEASED FOR PUBLICATION. ALL RIGHTS RESERVED. © 2000 BY TYCO ELECTRONICS CORPORATION.</small>		DWN C. CHEN 15DEC2011 CHK S. XI 15DEC2011 APVD J. CRUZ 15DEC2011	NAME TE Connectivity Harrisburg, PA 17105-3608
DIMENSIONS: mm 0 PLC ± 1 PLC ± 2 PLC ± 3 PLC ± 4 PLC ± ANGLES ± FINISH	TOLERANCES UNLESS OTHERWISE SPECIFIED: mm 0 PLC ± 1 PLC ± 2 PLC ± 3 PLC ± 4 PLC ± ANGLES ± FINISH	PRODUCT SPEC APPLICATION SPEC WEIGHT SCALE 1:2 SHEET 2 OF 4 REV L	SIZE CAGE CODE DRAWING NO A1 00779 C=2151411 RESTRICTED TO

THIS DRAWING IS UNPUBLISHED.	RELEASED FOR PUBLICATION		
COPYRIGHT 20 BY TYCO ELECTRONICS CORPORATION. ALL RIGHTS RESERVED.			
PART NUMBER	REVISION	DESCRIPTION	FEED TYPE
2-2151411-2	L	FINE CRIMP HEIGHT ADJUST	PNEUMATIC
7-2151411-7	E	CRIMP TOOLING KIT	-

PACIFIC VERSION TERMINATOR
INTERFACE ADAPTER

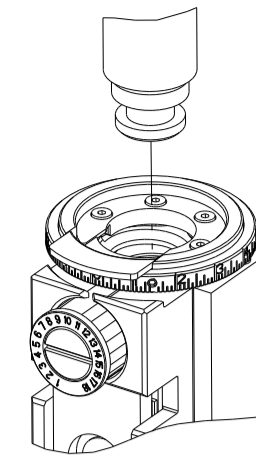

APPLICATOR DATA		
CRIMP	SIZE	TYPE
WIRE	5.33 mm [.210]	F
INSUL	5.59 mm [.220]	O
APPLICATOR INSTRUCTIONS 408-35042		

TERMINAL DATA: TE TERMINAL		TE CRIMP SPECIFICATION	
TERMINAL NAME: MALE TYPE XII CONTACT ASSEMBLY			
WIRE STRIP LENGTH 7.54-9.12 mm [.297-.359 IN]		INSULATION DIAMETER RANGE Ø 4.83-5.59 mm [.190-.220 IN]	
TERMINAL APPLICATION SPECIFICATION	114-10005	-	-
TERMINALS APPLIED			
TE TERMINAL	TE TERMINAL	TE TERMINAL	TE TERMINAL
66253-5	66253-6	66253-8	1-66253-0
66741-9	1-66741-1	1-66741-2	2-66741-0
172738-2	172738-3	1-172738-1	1-172738-2
66254-5			

WIRE SIZE	CRIMP HEIGHT mm [INCH]	CRIMP HEIGHT REFERENCE SETTING
10 AWG	2.82 +/- 0.10 [.111 +/- .004]	8.4

- △ RECOMMENDED SPARE PARTS.
- △ REFER TO SUPPLIED INSTRUCTION SHEET FOR CLEANING, LUBRICATION AND STORAGE OF APPLICATOR.
- △ APPLY PART NUMBER 2-23419-6 LOCTITE TO THREADS OF ITEM 242.
- △ CRIMP HEIGHT REFERENCE SETTING WAS THE SETTING USED WHEN THE APPLICATOR WAS QUALIFIED AT THE FACTORY. ADJUSTMENT MAY BE NECESSARY WHEN RUNNING APPLICATOR IN THE FIELD.
- △ TERMINAL PITCH NOT COMPATIBLE WITH MECHANICAL FEED.
- △ MARKING FROM WIRE CRIMPER IN TRANSITION AREA BETWEEN WIRE BARREL AND RECEPTACLE IS NECESSARY TO MAINTAIN GAP OF RECEPTACLE.
- 7. UNLESS SPECIFIED OTHERWISE TORQUE VALUES SHALL BE USED PER DOCUMENT, 101-35000.
- △ TERMINAL LUBRICANT IS RECOMMENDED.

***WARNING**
ON INSTALLATION, SET WIRE DISC TO CRIMP HEIGHT REFERENCE SETTING FOR LARGEST WIRE SIZE. CRIMP HEIGHT REFERENCE SETTINGS GREATER THAN THE VALUE SHOWN MAY CAUSE DAMAGE TO THE CRIMP TOOLING. REFER TO THE INSTRUCTION SHEET FOR PROPER SETUP AND ADJUSTMENTS.

LOC	DIST	REVISIONS					
A	66	P	LTN	DESCRIPTION	DATE	OWN	APVD
		-		SEE SHEET 1	-	-	-

-	1	2119082-8	CAM, SNAIL, INSULATION ADJUSTMENT	244	
-	1	2079764-1	WASHER, WAVE SPRING, CREST-TO-CREST	243	
3	-	1	2119083-1	RETAINER, INSULATION DIAL	242
-	1	7-18023-7	SCR, SKT HD CAP M3 X 4.0	241	
-	1	2844940-2	AIR FEED MODULE	238	
-	REF	994970-2	COUNTER, MAGNETIC	164	
-	1	2119641-2	FEED CAM, AIR FEED	151	
-	1	2168083-8	SCR, SKT HD CAP, RoHS, M4 X 16	144	
-	4	2168083-9	SCR, SKT HD CAP, RoHS, M4 X 20	143	
-	1	1-1803583-0	APPLICATOR BASIC ASSEMBLY, SF	141	
-	1	1803516-2	RAM ASSEMBLY, SF PACIFIC	140	
-	1	1-18028-2	WASHER, FLAT, REG M4	119	
8	-	1	2119955-1	ASSY, LUBRICATOR, SIDE FEED	113
-	1	2844908-1	SCREW, LOCKING	99	
-	1	2844907-1	POST, LOCKING	98	
-	1	1-690438-0	FRONT STRIP GUIDE	96	
-	1	1803078-2	SPACER, PRECISION	83	
-	1	1-455888-2	SPACER, CRIMPER	82	
-	2	1-2079383-8	SCR, BHSC, RoHS (M4 X 6)	79	
-	1	1803096-1	EXTENSION PLATE	78	
-	1	1803607-3	DOCUMENTATION PACKAGE	71	
-	1	2119791-9	DEPRESSOR, WIRE	70	
-	1	2119740-1	TAG IDENTIFICATION	67	
-	2	2168078-1	SCREW, DRIVE, RH, RoHS, 2 x .188	66	
-	1	5-18022-5	SCR, HEX HD CAP, M4 X 6.0	59	
-	1	2168083-3	SCR, SKT HD CAP, RoHS, M4 X 12.0	57	
-	1	1-1338683-1	FEED PAWL	56	
-	1	5018030-1	NUT, HEX, REG, RoHS, M3	52	
-	1	811242-6	BUMPER, HOLD DOWN	51	
-	1	690753-2	SPACER, TONKER	50	
-	1	18023-9	SCR, SKT HD CAP M4 X 6.0	49	
-	1	1803602-2	SCR, BHSC, RoHS (M8 X 40)	41	
-	1	3-1752356-3	SUPPORT, TERMINAL	34	
-	2	2079383-5	SCR, BHSC, RoHS (M4 X 20)	33	
-	2	2-2844962-6	SPACER, CYLINDRICAL, STRIP GUIDE	30	
-	1	2844992-5	ASSEMBLY, STRIP GUIDE	29	
-	2	22283-1	SPRING, COMPRESSION	27	
-	1	240792-1	DRAG, TERMINAL	25	
-	1	2-1320928-4	STRIP GUIDE	24	
-	1	2168083-2	SCR, SKT HD CAP, RoHS, M4 X 8.0	21	
-	1	1-18028-2	WASHER, FLAT, REG M4	20	
-	1	2119533-1	STRIPPER, SIDE FEED	19	
1	-	1	2119806-1	INSERT, SHEAR	13
-	1	5-22280-0	SPRING, COMPRESSION	12	
-	1	1-356885-4	STOP, SHEAR	11	
1	-	1	2-2119805-1	SHEAR HOLDER, FRONT	10
1	-	1	454276-5	FLOATING SHEAR, FRONT	9
1	1	1	1333211-6	ANVIL, COMBINATION .150-.300	8
-	1	5-240641-9	SPACER	7	
-	-	-	-	6	
-	1	1-2119757-3	DEPRESSOR, SHEAR	5	
-	1	238011-1	BLOCK, CRIMPER SPACER	4	
1	1	1	7-1633966-6	CRIMPER, INSULATION O	3
-	1	455888-6	SPACER, CRIMPER	2	
1	1	1	1-456430-5	CRIMPER, WIRE	1
-	77	-22	PART NO	DESCRIPTION	ITEM NO

PACIFIC VERSION
Shown on sheets 3 of 4 & 4 of 4
(Atlantic version shown on sheets 1 of 4 & 2 of 4)

DIMENSIONS:		TOLERANCES UNLESS OTHERWISE SPECIFIED:		OWN: C. CHEN 15DEC2011	STE TE Connectivity Harrisburg, PA 17105-3608
mm		0 PLC ±		CHK: S. XI 15DEC2011	
APVD: J. CRUZ 15DEC2011		1 PLC ±		NAME: Ocean Side Feed	APPLICATOR
PRODUCT SPEC		2 PLC ±		SIZE: A1	
APPLICATION SPEC		3 PLC ±		CAGE CODE: 00779	DRAWING NO: C=2151411
MATERIAL		4 PLC ±		SCALE: 1:2	
FINISH		ANGLES		SHEET: 3 OF 4	REV: L
WEIGHT		FINISH		Customer Accessible Production Drawing	

LOC	DIST	REVISIONS					
		P	LTN	DESCRIPTION	DATE	OWN	APVD
A	66	-	-	SEE SHEET 1	-	-	-

FEED TYPE

PNEUMATIC

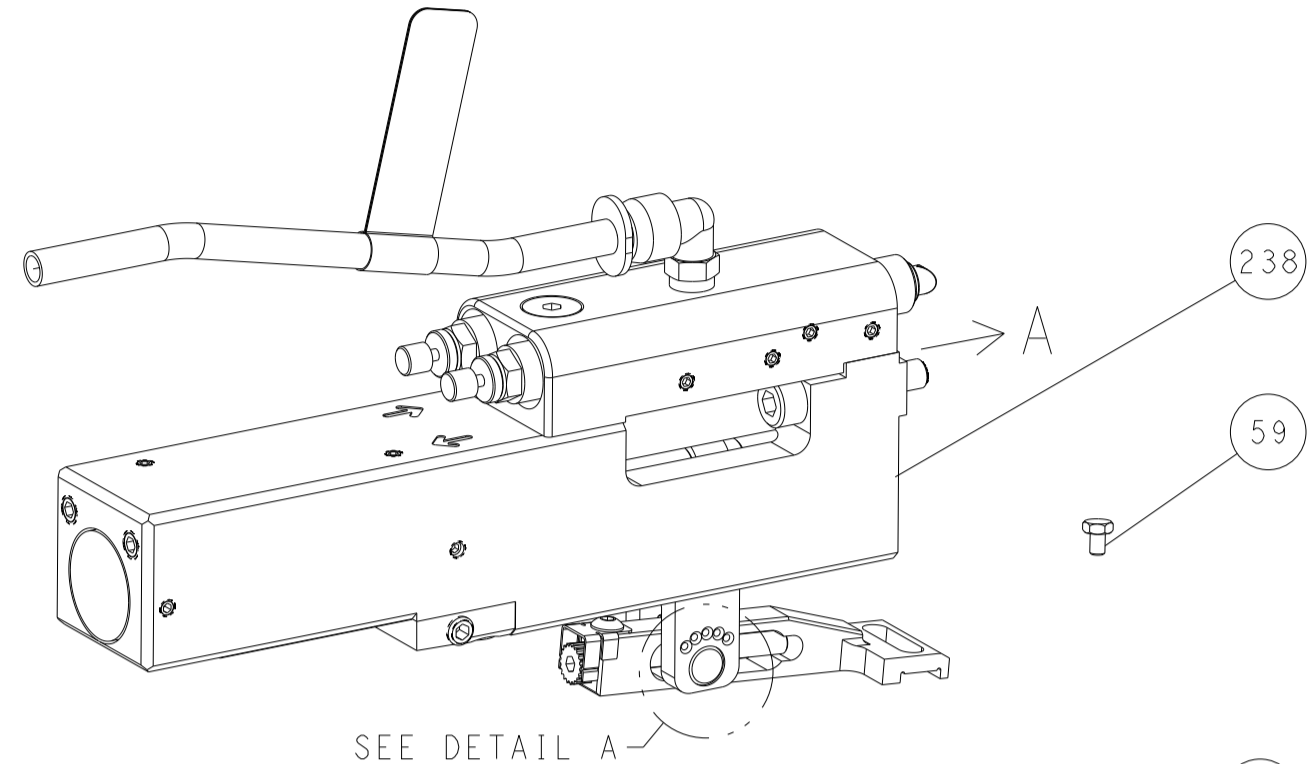

SEE DETAIL A

FEED SPRING SETTING POSITION (SHOWN FROM REAR SIDE)

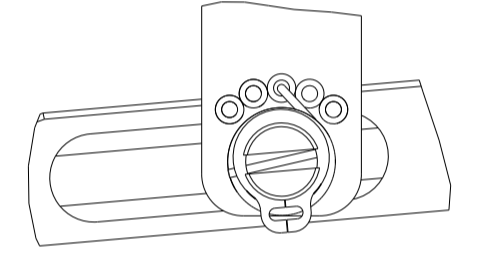

DETAIL A

CAM POSITION

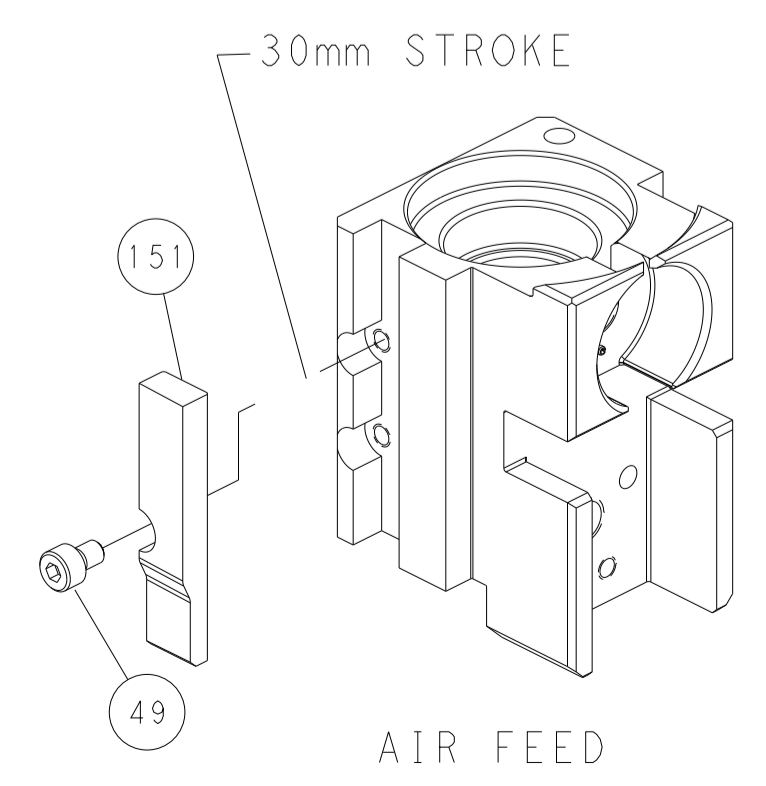

AIR FEED

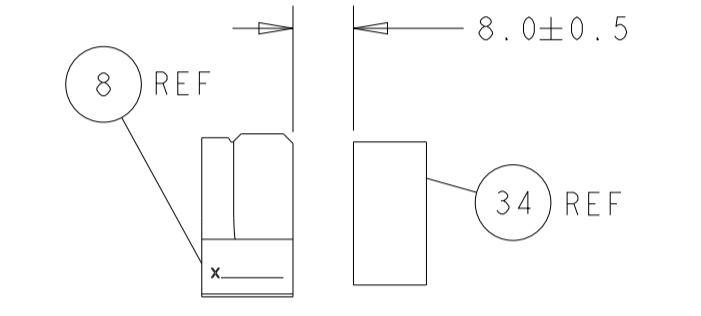
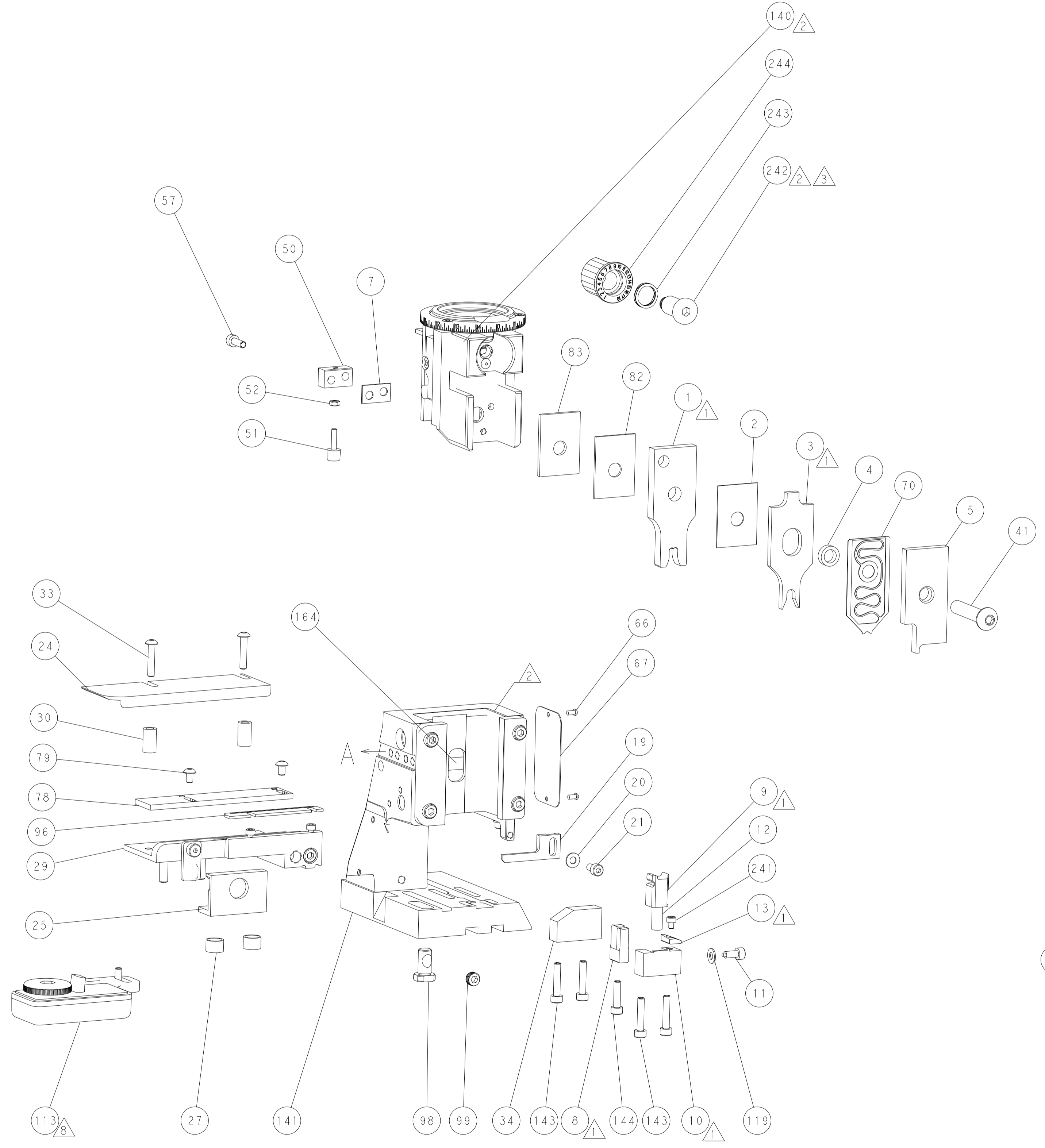

TERMINAL SUPPORT LOCATION

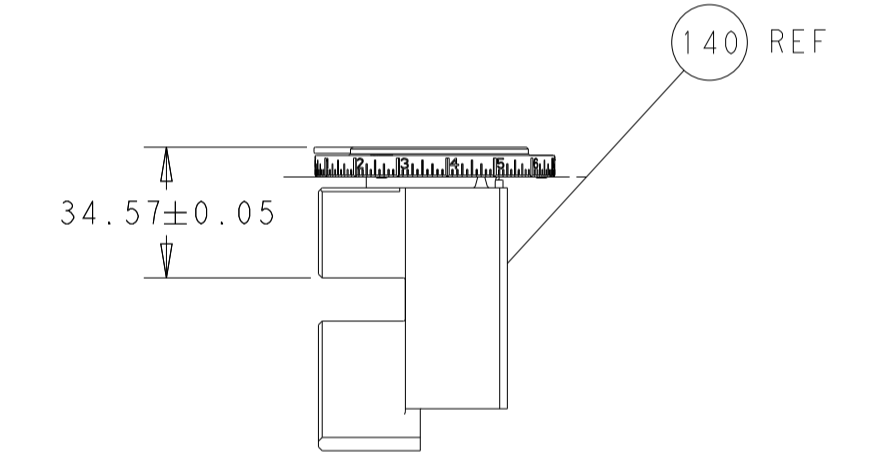

RAM SET-UP

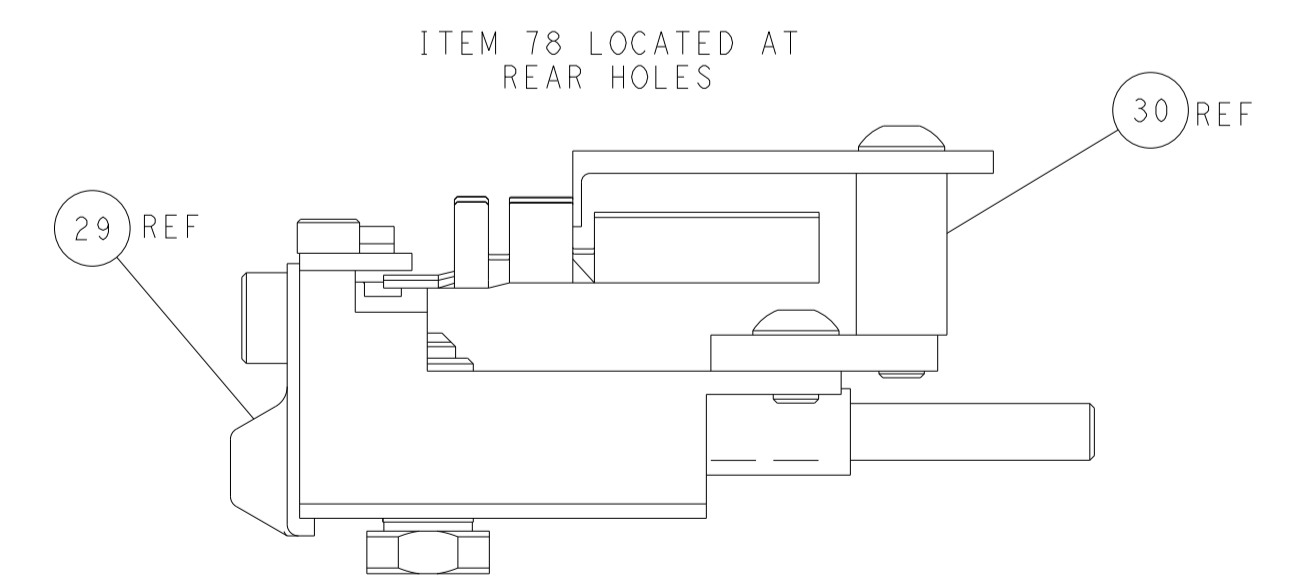

FEED TRACK POSITION GUIDE BY WIRE BARREL

PACIFIC VERSION
 Shown on sheets 3 of 4 & 4 of 4
 (Atlantic version shown on sheets 1 of 4 & 2 of 4)

<small>THIS DRAWING IS UNPUBLISHED. RELEASED FOR PUBLICATION. ALL RIGHTS RESERVED. THIS DRAWING IS UNPUBLISHED. RELEASED FOR PUBLICATION. ALL RIGHTS RESERVED. THIS DRAWING IS UNPUBLISHED. RELEASED FOR PUBLICATION. ALL RIGHTS RESERVED.</small>		DWN C. CHEN 15DEC2011 CHK S. XI 15DEC2011 APVD J. CRUZ 15DEC2011	TE Connectivity Harrisburg, PA 17105-3608
DIMENSIONS: mm TOLERANCES UNLESS OTHERWISE SPECIFIED: 0 PLC ± 1 PLC ± 2 PLC ± 3 PLC ± 4 PLC ± ANGLES ± FINISH		NAME Ocean Side Feed Applicator PRODUCT SPEC APPLICATION SPEC SIZE CAGE CODE DRAWING NO A1 00779 C-2151411	RESTRICTED TO Customer Accessible Production Drawing SCALE 1:2 SHEET 4 OF 4 REV L