

LOC		DIST		REVISIONS				
GP	00	REV	DATE	BY	CHK	APPV		
G		REVISED PER ECO-09-002944	19MAR2009	CR	SB			

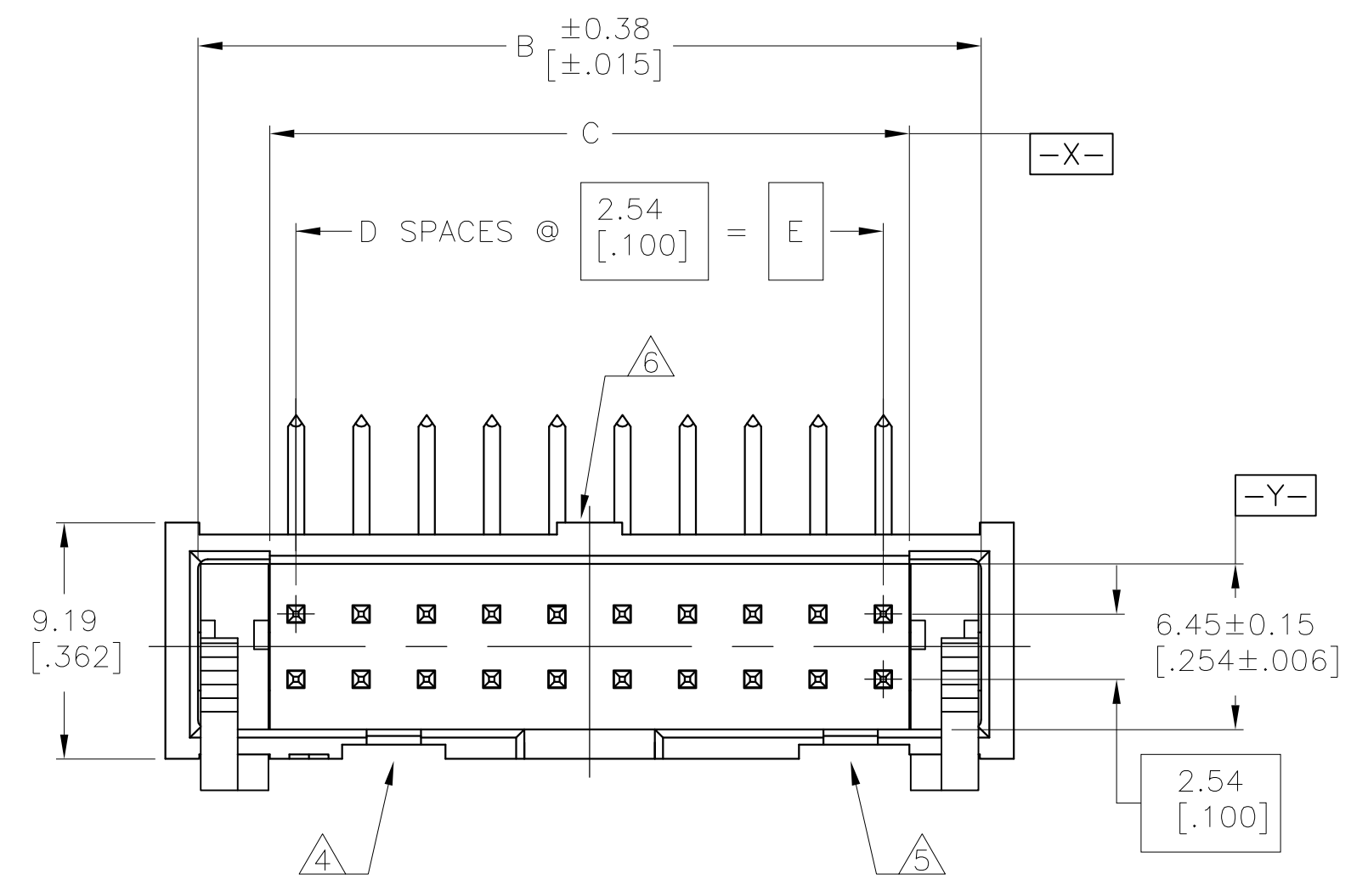

- △ HOUSING: PBT, UL94V-0, COLOR: BLUE.  
POSTS: PHOSPHOR BRONZE.  
LATCHES: ZINC ALLOY.
- △ POSTS: GOLD FLASH OVER PALLADIUM-NICKEL PLATE,  $0.76\mu\text{m}$  [ $.000030$ ] MIN TOTAL ON MATING AREA,  $2.54\mu\text{m}$  [ $.000100$ ] MIN TIN PLATE ON SOLDER-TAIL, ALL OVER  $1.27\mu\text{m}$  [ $.000050$ ] MIN NICKEL UNDERPLATE ON ENTIRE POST.  
OR  
 $0.76\mu\text{m}$  [ $.000030$ ] MIN GOLD PLATE ON MATING AREA,  $2.54\mu\text{m}$  [ $.000100$ ] MIN TIN PLATE ON THE SOLDER-TAIL,  $1.27\mu\text{m}$  [ $.000050$ ] MIN NICKEL UNDERPLATE ON THE ENTIRE POST.  
LATCHES: BLACK NICKEL OVER COPPER.
- △ DATUMS S & T TO BE ESTABLISHED BY CUSTOMER.
- △ NO KEYING SLOT ON THIS END FOR 8, 10 & 14 POSITION ASSEMBLIES.
- △ NO KEYING SLOT ON THIS END FOR 8 & 10 POSITION ASSEMBLIES.
- △ NO STANDOFF FOR 8, 10, 14 & 16 POSITION ASSEMBLIES.
- △ ALTERNATE LOCATION/ORIENTATION FOR POSITION #1 INDICATOR.

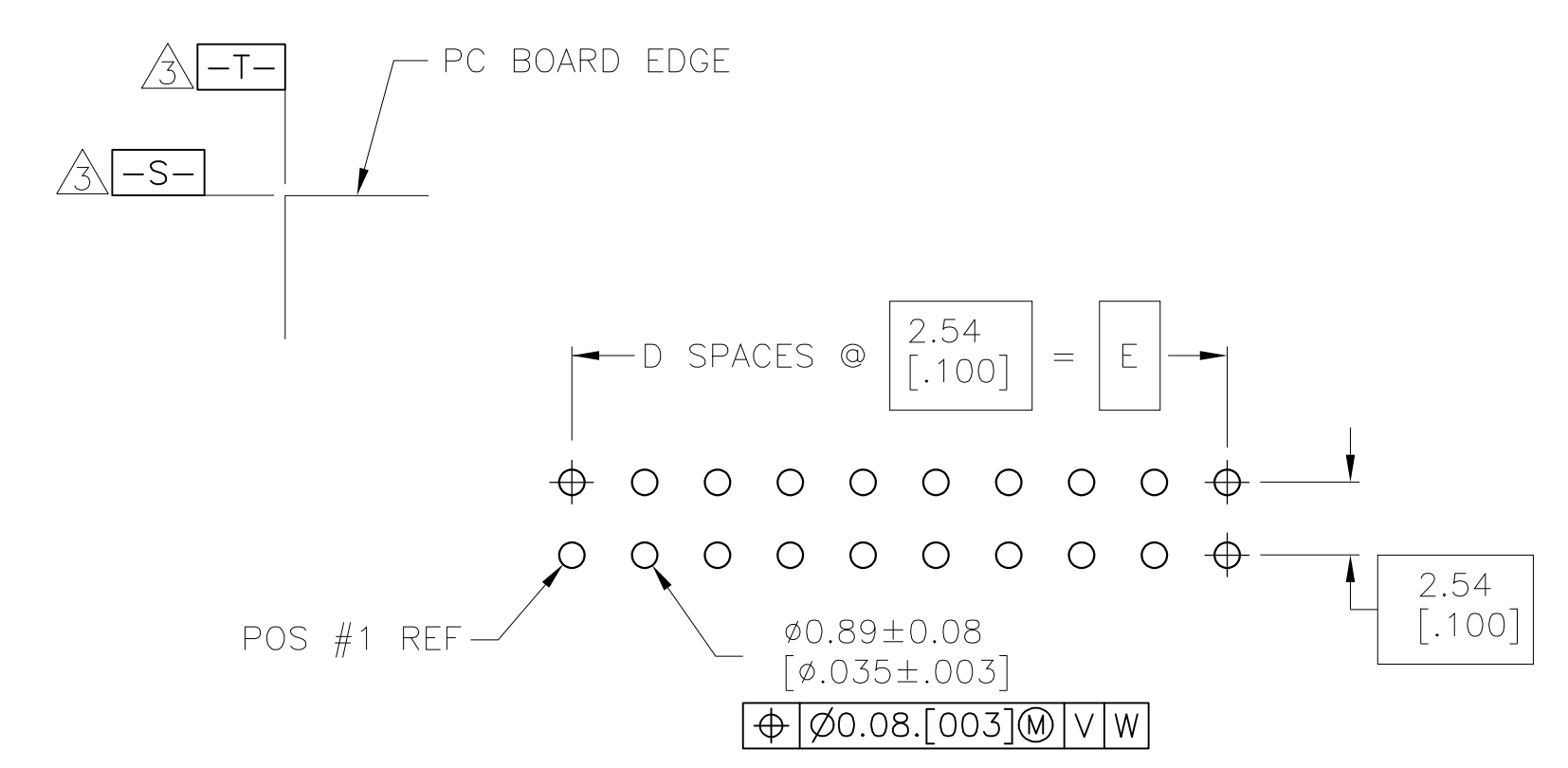
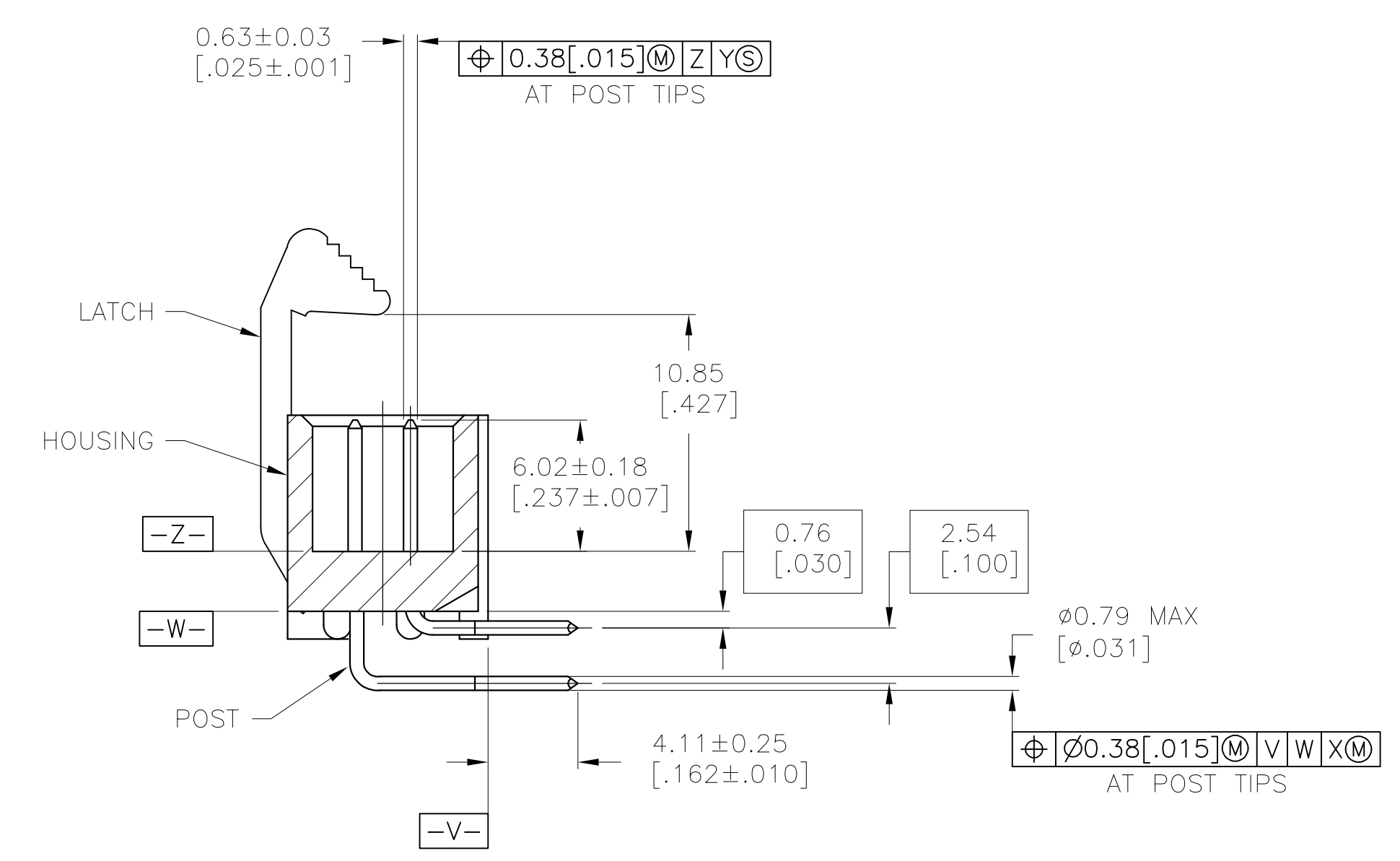
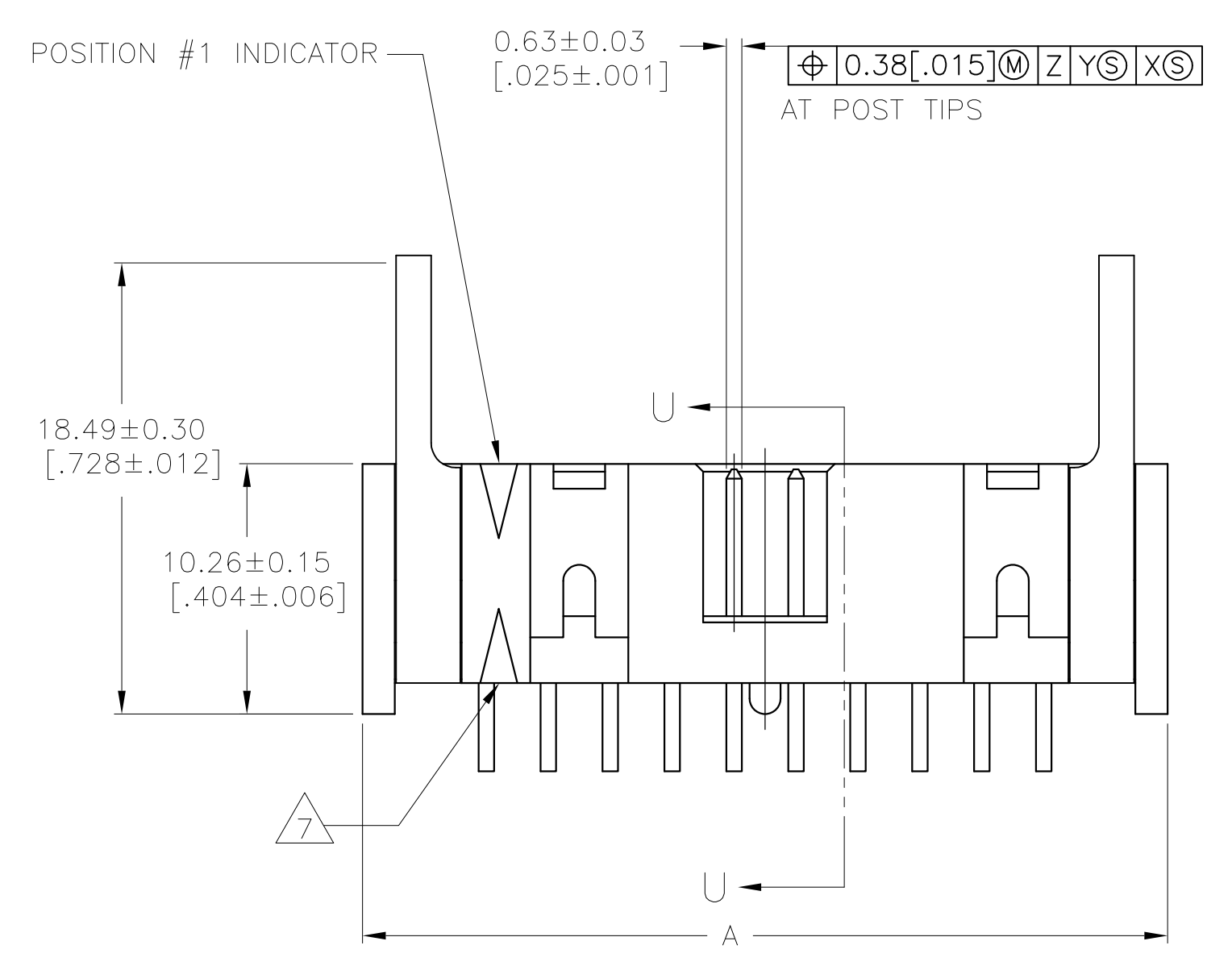

RECOMMENDED PC BOARD LAYOUT  
(VIEWED FROM CONNECTOR SIDE)

	E	D	C	B	A	NO OF POS	PART NUMBER
OBSOLETE	60.96 [2.400]	24	62.99 [2.480]	68.48 [2.696]	71.12 [2.800]	50	3-1761714-5
	40.64 [1.600]	16	42.67 [1.680]	48.16 [1.896]	50.80 [2.000]	34	3-1761714-1
	30.48 [1.200]	12	32.51 [1.280]	38.00 [1.496]	40.64 [1.600]	26	2-1761714-9
	27.94 [1.100]	11	29.97 [1.180]	35.46 [1.396]	38.10 [1.500]	24	2-1761714-8
OBSOLETE	22.86 [.900]	9	24.89 [.980]	30.38 [1.196]	33.02 [1.300]	20	2-1761714-7
	17.78 [.700]	7	19.81 [.780]	25.30 [.996]	27.94 [1.100]	16	2-1761714-6
OBSOLETE	15.24 [.600]	6	17.27 [.680]	22.76 [.896]	25.40 [1.000]	14	2-1761714-5
	10.16 [.400]	4	12.19 [.480]	17.68 [.696]	20.32 [.800]	10	2-1761714-3
	7.62 [.300]	3	9.65 [.380]	15.14 [.596]	17.78 [.700]	8	2-1761714-2

THIS DRAWING IS A CONTROLLED DOCUMENT.

DIMENSIONS: mm [INCHES]	TOLERANCES UNLESS OTHERWISE SPECIFIED:	DIN B. CRISAMORE/DJI 30JUN05	CHK S. BOLASH 30JUN05	APPRO M. WALMSLEY 30JUN05	NAME M. WALMSLEY	PRODUCT SPEC	APPLICATION SPEC	SIZE A1	CAGE CODE 00779	DRAWING NO. 1761714	RESTRICTED TO
0 PLC ± -	1 PLC ± -	2 PLC ± -	3 PLC ± 0.1% (.005)	4 PLC ± -	ANGLES ± -	FINISH	WEIGHT	SCALE 4:1	SHEET 1 OF 1	REV G	

CUSTOMER DRAWING