

ELECTRICAL:

EMI SHIELDING : SHIELDED FOR THE RANGE 55dB UP TO 100MHZ

INSULATION RESISTANCE : >500MΩ PER ANSI-EIA-364-D METHOD 21

MAX. CURRENT RATING : SEE INSULATOR DRAWING

CONNECTOR TESTING VOLTAGE : SEE INSULATOR DRAWING

CONNECTOR WORKING VOLTAGE : SEE INSULATOR DRAWING

PHYSICAL:

MAXIMUM WIRE SIZE USED : SEE INSULATOR DRAWING

CABLE DIAMETER WITH PLASTIC COLLET SET SUPPLIED: Ø1.5mm MIN. TO Ø5.5mm MAX.

ENVIRONMENTAL:

ENDURANCE: 1000 CYCLES AS PER MIL-STD 1344A, METHOD 2016.1

SHOCK: 50 g , DURATION 6 ms; AS PER MIL-STD 1344A, METHOD 2004.1

VIBRATIONS: 10 TO 2000Hz g = 15g, AS PER MIL-STD 1344A, METHOD 2005.1

PROTECTION INDEX: IP 67 AS PER CEI 529

ROHS COMPLIANT

SALT MIST : 48Hr PER SAE AS 1344 METHOD 1001.1 CEI 529

OPERATING TEMPERATURE:

WITH PLASTIC COLLETS: -40°C TO +80°C (-40°F TO +176°F)

MASS (g)	VOLUME (mm ³)
9.1	1501

NOTES:

1 RED DOT.

MATERIAL:

OUTER SHELL & BACK NUT : } BRASS
 LATCHING SLEEVE }
 HALF BUSHES : }

COLLET : RUBBER

FINISH:

OUTER SHELL & BACK NUT : CHROME

OTHER BRASS PARTS : NICKEL

T TOOLS

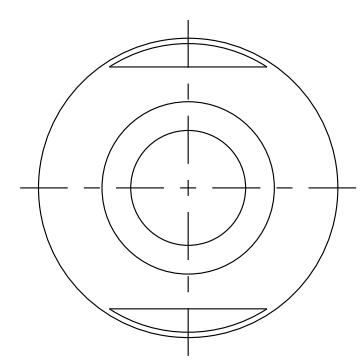

WIRE SIDE VIEW

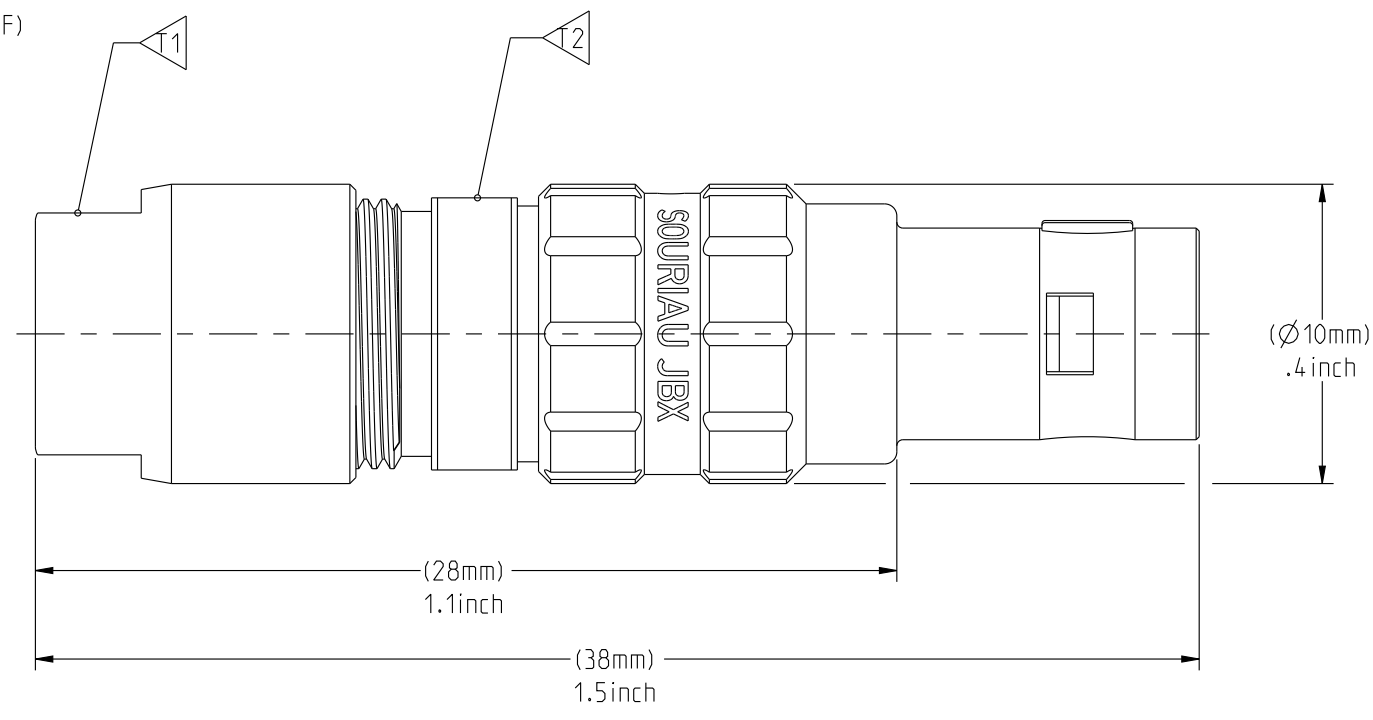

(ASSEMBLED VIEW FOR INFORMATION ONLY)

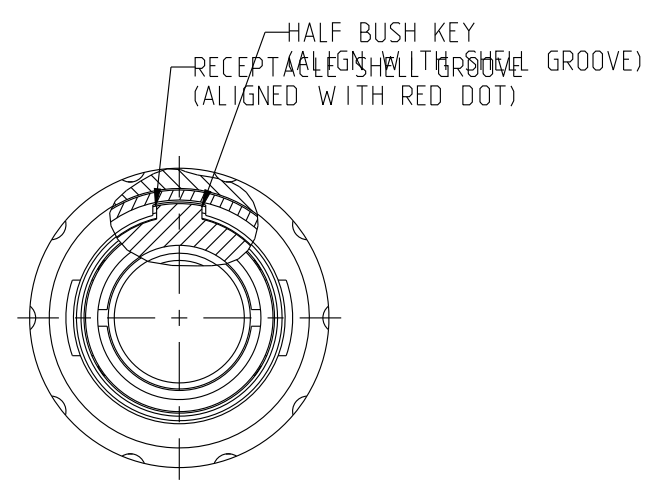

MATING SIDE VIEW

PART LIST	
ITEM NO.	DESCRIPTION
1	SLEEVE
2	HALF BUSH WITH WINDOW
3	HALF BUSH WITHOUT WINDOW
4	INSULATOR
5	Ø1.5-Ø5.5 CABLE COLLET (CHOOSE PER CABLE SIZE)
6	STANDARD BACK NUT
6a	BACK NUT FOR PROTECTIVE BOOT (OPTIONAL)

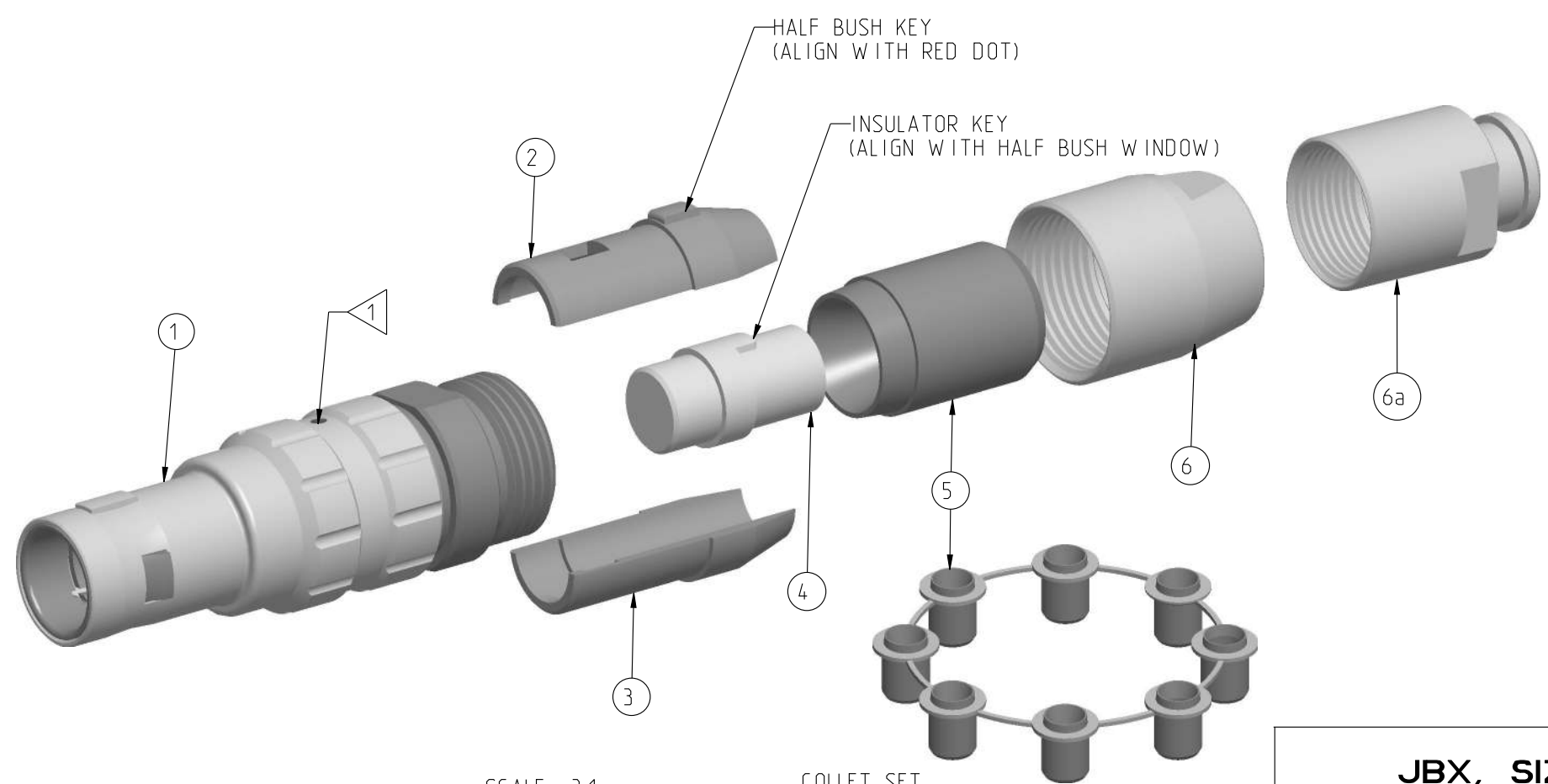

SCALE 3:1

COLLET SET SCALE 1:1

	TOOLS (JAW DIMENSION)	ADVISED TORQUE IN Nm
T1	8	0.8
T2	9	-

CATALOG NUMBER DESCRIPTION

JBX FH 0 XXXXXX DXX

BASIC SERIES _____

SHELL TYPE _____

SHELL SIZE _____

KEYING _____

SEE INSULATOR DRAWING _____

OPTION _____

INSERT MATERIAL _____

COLLET OPTION _____

SURFACE PLATING _____

ORIGIN	COUNTRY	JURISDICTION	CLASSIFICATION
X	FR	Not listed	N/A
	US	EAR	ECCN =EAR99

These commodities, technology or software are exported from the United States in accordance with the Export Administration Regulations. Diversion contrary to U.S. law is prohibited.

LINEAR MEASURE:	mm (INCH)
THIRD ANGLE PROJECTION	
TOLERANCES UNLESS OTHERWISE SPECIFIED	
No. OF PLACES	mm [INCH]
WHOLE No.	±0.5 [±.02]
ONE PLACE	±0.2 [±.008]
TWO PLACES	±0.1 [±.004]
ANGLES ±1°	

A	RELEASED PER ECN 12258	TJS 06-10-15	EV 06-10-15
REV	DESCRIPTION	BY DATE	CHKD DATE

DRAWING TITLE: **JBX, SIZE 0, SEALED STRAIGHT PLUG**

CAT NO. **JBXFHO**

CAGE NO: 09922 SIZE: C

CUSTOMER

SOURIAU

www.souriau.com

1 OF 1

APPROVAL

DRAWN: SKV	01-08-15
CHKD: EV	01-08-15
DSGN: EV	01-08-15
MFG: DH	01-08-15
QC: BB	01-08-15

DRAWING SCALE: 4:1

DRAWING NO. **JBXFHOC** REV **A**

THIS DRAWING IS A CONTROLLED DOCUMENT FOR SOURIAU USA, INC. IT IS SUBJECT TO CHANGE WITHOUT NOTIFICATION. CONTACT THE DOCUMENT CONTROL CENTER FOR THE LATEST REVISION.

THE INFORMATION CONTAINED IN THIS DRAWING IS CONFIDENTIAL AND MAY NOT BE DISCLOSED WITHOUT WRITTEN CONSENT FROM SOURIAU USA, INC.

DWG. NO.
JBX0INSMCC

MALE INSULATOR, CRIMP CONTACT

CONTACT LAYOUT	02	03	04	05	
FRONT SIDE VIEW					
REAR SIDE VIEW					
CONTACT					
ISO VIEW					
CONTACT	ØC	0.9	0.9	0.7	0.7
	ØF	1.1	1.1	0.85	0.85
	MAX. AWG	20	20	22	22
	MAX. CURRENT RATING (A)	10	10	7	7
	CONTACT RESISTANCE (mΩ)	3.5	3.5	5	5
INSULATOR	NUMBER OF CAVITY	2	3	4	5
	MAX. CURRENT RATING	10	8	7	6.5
	TEST VOLTAGE (Vrms)	1400	1300	1350	800
	WORKING VOLTAGE (Vdc/Vrms)	600/460	600/420	660/460	400/260

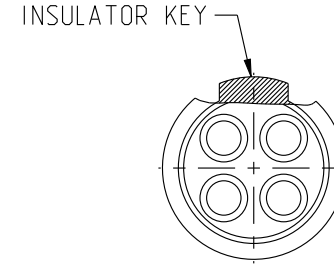

CONTACT TYPE : M (MALE)
CONTACT TERMINATION : C (CRIMP)
MATERIAL :
 CONTACT: BRASS
 CLIP: COPPER ALLOY
 INSULATOR: PEEK
FINISH :
 CONTACTS : GOLD

CATALOG NUMBER DESCRIPTION

JBXXX 0 XYM CXXXX

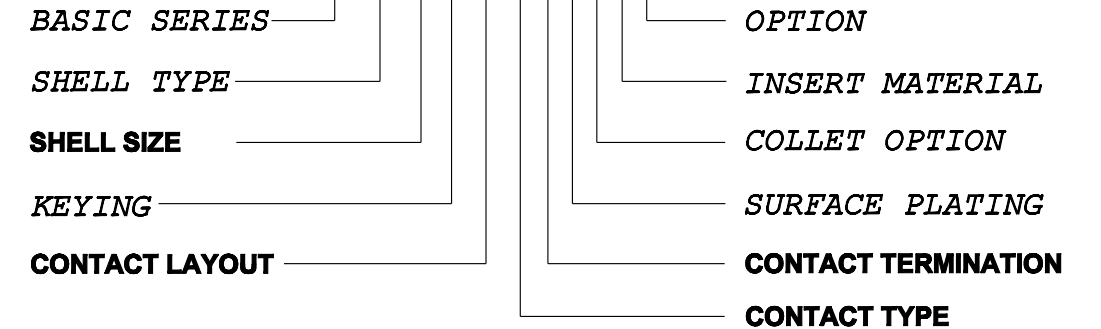

B	REVISED PER ECN 12286	RSK 06-10-15	EV 06-10-15
A	RELEASED PER ECN 12264	TJS 03-10-15	EV 03-10-15
REV	DESCRIPTION	BY DATE	CHKD DATE

DRAWING TITLE
JBX, SIZE 0, MALE INSULATOR, CRIMP CONTACT

CAT NO. **JBX0INSMC**

CAGE NO: 09922 SIZE: B

CUSTOMER	SOURIAU	APPROVAL	DRAWN: TJS	02-04-15
			CHKD : EV	02-04-15
INTERPRET THIS DRAWING IN ACCORDANCE WITH ASME Y14.5M - 1994.	WWW.SOURIAU.COM		DSGN : EV	02-04-15
			MFG : DH	02-04-15
			QC : BB	02-04-15
			DRAWING SCALE: NA	
			DRAWING NO.	REV
			JBX0INSMCC	B
			1 OF 1	

ORIGIN	COUNTRY	JURISDICTION	CLASSIFICATION
X	FR	Not listed	N/A
	US	EAR	ECCN =EAR99

These commodities, technology or software are exported from the United States in accordance with the Export Administration Regulations. Diversion contrary to U.S. law is prohibited

LINEAR MEASURE: $\frac{mm}{INCH}$ mm (INCH)
 THIRD ANGLE PROJECTION

 TOLERANCES UNLESS OTHERWISE SPECIFIED
 No. OF PLACES mm [INCH]
 ONE PLACE ±3 [±.1]
 TWO PLACES ±0.5 [±.02]
 THREE PLACES ±0.25 [±.010]
 ANGLES ±1°

THIS DRAWING IS A CONTROLLED DOCUMENT FOR SOURIAU USA, INC. IT IS SUBJECT TO CHANGE WITHOUT NOTIFICATION. CONTACT THE DOCUMENT CONTROL CENTER FOR THE LATEST REVISION.

THE INFORMATION CONTAINED IN THIS DRAWING IS CONFIDENTIAL AND MAY NOT BE DISCLOSED WITHOUT WRITTEN CONSENT FROM SOURIAU USA, INC.

B

A