



**MICROCHIP**

---

**dsPIC33EP128GS806**  
**Digital Power**  
**Plug-In Module (PIM)**  
**User's Guide**

---

**Note the following details of the code protection feature on Microchip devices:**

- Microchip products meet the specification contained in their particular Microchip Data Sheet.
- Microchip believes that its family of products is one of the most secure families of its kind on the market today, when used in the intended manner and under normal conditions.
- There are dishonest and possibly illegal methods used to breach the code protection feature. All of these methods, to our knowledge, require using the Microchip products in a manner outside the operating specifications contained in Microchip's Data Sheets. Most likely, the person doing so is engaged in theft of intellectual property.
- Microchip is willing to work with the customer who is concerned about the integrity of their code.
- Neither Microchip nor any other semiconductor manufacturer can guarantee the security of their code. Code protection does not mean that we are guaranteeing the product as "unbreakable."

Code protection is constantly evolving. We at Microchip are committed to continuously improving the code protection features of our products. Attempts to break Microchip's code protection feature may be a violation of the Digital Millennium Copyright Act. If such acts allow unauthorized access to your software or other copyrighted work, you may have a right to sue for relief under that Act.

---

Information contained in this publication regarding device applications and the like is provided only for your convenience and may be superseded by updates. It is your responsibility to ensure that your application meets with your specifications. MICROCHIP MAKES NO REPRESENTATIONS OR WARRANTIES OF ANY KIND WHETHER EXPRESS OR IMPLIED, WRITTEN OR ORAL, STATUTORY OR OTHERWISE, RELATED TO THE INFORMATION, INCLUDING BUT NOT LIMITED TO ITS CONDITION, QUALITY, PERFORMANCE, MERCHANTABILITY OR FITNESS FOR PURPOSE. Microchip disclaims all liability arising from this information and its use. Use of Microchip devices in life support and/or safety applications is entirely at the buyer's risk, and the buyer agrees to defend, indemnify and hold harmless Microchip from any and all damages, claims, suits, or expenses resulting from such use. No licenses are conveyed, implicitly or otherwise, under any Microchip intellectual property rights unless otherwise stated.

*Microchip received ISO/TS-16949:2009 certification for its worldwide headquarters, design and wafer fabrication facilities in Chandler and Tempe, Arizona; Gresham, Oregon and design centers in California and India. The Company's quality system processes and procedures are for its PIC<sup>®</sup> MCUs and dsPIC<sup>®</sup> DSCs, KEELOQ<sup>®</sup> code hopping devices, Serial EEPROMs, microperipherals, nonvolatile memory and analog products. In addition, Microchip's quality system for the design and manufacture of development systems is ISO 9001:2000 certified.*

**QUALITY MANAGEMENT SYSTEM  
CERTIFIED BY DNV  
= ISO/TS 16949 =**

**Trademarks**

The Microchip name and logo, the Microchip logo, AnyRate, AVR, AVR logo, AVR Freaks, BitCloud, CryptoMemory, CryptoRF, dsPIC, FlashFlex, flexPWR, Heldo, JukeBlox, KeeLoq, Klear, LANCheck, LINK MD, maXStylus, maXTouch, MediaLB, megaAVR, MOST, MOST logo, MPLAB, OptoLyzer, PIC, picoPower, PICSTART, PIC32 logo, Prochip Designer, QTouch, SAM-BA, SpyNIC, SST, SST Logo, SuperFlash, tinyAVR, UNI/O, and XMEGA are registered trademarks of Microchip Technology Incorporated in the U.S.A. and other countries.

ClockWorks, The Embedded Control Solutions Company, EtherSynch, Hyper Speed Control, HyperLight Load, IntelliMOS, mTouch, Precision Edge, and Quiet-Wire are registered trademarks of Microchip Technology Incorporated in the U.S.A.

Adjacent Key Suppression, AKS, Analog-for-the-Digital Age, Any Capacitor, AnyIn, AnyOut, BodyCom, chipKIT, chipKIT logo, CodeGuard, CryptoAuthentication, CryptoAutomotive, CryptoCompanion, CryptoController, dsPICDEM, dsPICDEM.net, Dynamic Average Matching, DAM, ECAN, EtherGREEN, In-Circuit Serial Programming, ICSP, INICnet, Inter-Chip Connectivity, JitterBlocker, KlearNet, KlearNet logo, memBrain, Mindi, MiWi, motorBench, MPASM, MPF, MPLAB Certified logo, MPLIB, MPLINK, MultiTRAK, NetDetach, Omniscient Code Generation, PICDEM, PICDEM.net, PICkit, PICTail, PowerSmart, PureSilicon, QMatrix, REAL ICE, Ripple Blocker, SAM-ICE, Serial Quad I/O, SMART-I.S., SQL, SuperSwitcher, SuperSwitcher II, Total Endurance, TSHARC, USBCheck, VariSense, ViewSpan, WiperLock, Wireless DNA, and ZENA are trademarks of Microchip Technology Incorporated in the U.S.A. and other countries.

SQTP is a service mark of Microchip Technology Incorporated in the U.S.A.

Silicon Storage Technology is a registered trademark of Microchip Technology Inc. in other countries.

GestIC is a registered trademarks of Microchip Technology Germany II GmbH & Co. KG, a subsidiary of Microchip Technology Inc., in other countries.

All other trademarks mentioned herein are property of their respective companies.

©2018, Microchip Technology Incorporated, All Rights Reserved.

ISBN: 978-1-5224-3283-8



# dsPIC33EP128GS806 DIGITAL POWER PIM USER'S GUIDE

---

---

## Table of Contents

---

---

<b>Preface</b> .....	<b>5</b>
<b>Chapter 1. Overview</b> .....	<b>9</b>
1.1 Introduction .....	9
1.2 Features .....	9
1.2.1 Electrical Characteristics .....	10
1.2.2 Analog and Digital Signals .....	10
1.2.3 dsPIC33EP128GS806 DP PIM – PCB Edge Connector .....	10
1.3 UART Communication .....	11
1.4 Low-Frequency Bode Plot Measurements .....	11
<b>Appendix A. Board Layout and Schematics</b> .....	<b>13</b>
A.1 Pinout .....	13
A.2 Board Schematics .....	15
A.3 PCB Layout .....	17
<b>Appendix B. Bill of Materials (BOM)</b> .....	<b>21</b>
B.1 Bill of Materials .....	21
<b>Worldwide Sales and Service</b> .....	<b>24</b>

# dsPIC33EP128GS806 Digital Power PIM User's Guide

---

---

NOTES:

---

---

## Preface

---

---

### NOTICE TO CUSTOMERS

All documentation becomes dated, and this manual is no exception. Microchip tools and documentation are constantly evolving to meet customer needs, so some actual dialogs and/or tool descriptions may differ from those in this document. Please refer to our website ([www.microchip.com](http://www.microchip.com)) to obtain the latest documentation available.

Documents are identified with a “DS” number. This number is located on the bottom of each page, in front of the page number. The numbering convention for the DS number is “DSXXXXXXXXA”, where “XXXXXXXX” is the document number and “A” is the revision level of the document.

For the most up-to-date information on development tools, see the MPLAB® IDE online help. Select the Help menu, and then Topics to open a list of available online help files.

## INTRODUCTION

This chapter contains general information that will be useful to know before using the dsPIC33EP128GS806 Digital Power Plug-In Module (PIM). Items discussed in this chapter include:

- [Document Layout](#)
- [Conventions Used in this Guide](#)
- [Recommended Reading](#)
- [The Microchip Website](#)
- [Product Change Notification Service](#)
- [Customer Support](#)
- [Document Revision History](#)

## DOCUMENT LAYOUT

This document describes how to use the dsPIC33EP128GS806 Digital Power PIM as a development tool to emulate and debug firmware on a target board. The document is organized as follows:

- **Chapter 1. “Overview”** – This chapter introduces the dsPIC33EP128GS806 Digital Power PIM and provides a brief overview of its various features.
- **Appendix A. “Board Layout and Schematics”** – This appendix presents the schematics and the board layouts for the dsPIC33EP128GS806 Digital Power PIM.
- **Appendix B. “Bill of Materials (BOM)”** – This appendix presents the Bill of Materials for the dsPIC33EP128GS806 Digital Power PIM.

# dsPIC33EP128GS806 Digital Power PIM User's Guide

## CONVENTIONS USED IN THIS GUIDE

This manual uses the following documentation conventions:

### DOCUMENTATION CONVENTIONS

Description	Represents	Examples
<b>Arial font:</b>		
Italic characters	Referenced books	<i>MPLAB<sup>®</sup> IDE User's Guide</i>
	Emphasized text	...is the <i>only</i> compiler...
Initial caps	A window	the Output window
	A dialog	the Settings dialog
	A menu selection	select Enable Programmer
Quotes	A field name in a window or dialog	"Save project before build"
Underlined, italic text with right angle bracket	A menu path	<u><i>File&gt;Save</i></u>
Bold characters	A dialog button	Click <b>OK</b>
	A tab	Click the <b>Power</b> tab
N'Rnnnn	A number in verilog format, where N is the total number of digits, R is the radix and n is a digit.	4'b0010, 2'hF1
Text in angle brackets < >	A key on the keyboard	Press <Enter>, <F1>
<b>Courier New font:</b>		
Plain Courier New	Sample source code	#define START
	Filenames	autoexec.bat
	File paths	c:\mcc18\h
	Keywords	_asm, _endasm, static
	Command-line options	-Opa+, -Opa-
	Bit values	0, 1
	Constants	0xFF, 'A'
Italic Courier New	A variable argument	<i>file.o</i> , where <i>file</i> can be any valid filename
Square brackets [ ]	Optional arguments	mcc18 [options] <i>file</i> [options]
Curly brackets and pipe character: {   }	Choice of mutually exclusive arguments; an OR selection	errorlevel {0 1}
Ellipses...	Replaces repeated text	var_name [, var_name...]
	Represents code supplied by user	void main (void) { ... }

## RECOMMENDED READING

This user's guide describes how to use the dsPIC33EP128GS806 Digital Power PIM. Other useful document(s) are listed below. The following Microchip document(s) are recommended as supplemental reference resources.

- **“dsPIC33EPXXGS70X/80X Family Data Sheet”** (DS70005258) and is available for download from the Microchip website ([www.microchip.com](http://www.microchip.com))

## THE MICROCHIP WEBSITE

Microchip provides online support via our website at [www.microchip.com](http://www.microchip.com). This website is used as a means to make files and information easily available to customers. Accessible by using your favorite Internet browser, the website contains the following information:

- **Product Support** – Data sheets and errata, application notes and sample programs, design resources, user's guides and hardware support documents, latest software releases and archived software
- **General Technical Support** – Frequently Asked Questions (FAQs), technical support requests, online discussion groups, Microchip consultant program member listing
- **Business of Microchip** – Product selector and ordering guides, latest Microchip press releases, listing of seminars and events; and listings of Microchip sales offices, distributors and factory representatives

## PRODUCT CHANGE NOTIFICATION SERVICE

Microchip's customer notification service helps keep customers current on Microchip products. Subscribers will receive e-mail notification whenever there are changes, updates, revisions or errata related to a specified product family or development tool of interest.

To register, access the Microchip website at [www.microchip.com](http://www.microchip.com), click on **Product Change Notification** and follow the registration instructions.

## CUSTOMER SUPPORT

Users of Microchip products can receive assistance through several channels:

- Distributor or Representative
- Local Sales Office
- Corporate Application Engineer (CAE)
- Embedded Solutions Engineer (ESE)

Customers should contact their distributor, representative or Embedded Solutions Engineer (ESE) for support. Local sales offices are also available to help customers. A listing of sales offices and locations is included in the back of this document.

Technical support is available through the website at:

<http://www.microchip.com/support>.

## DOCUMENT REVISION HISTORY

### Revision A (June 2018)

This is the initial release of this document.

# dsPIC33EP128GS806 Digital Power PIM User's Guide

---

---

NOTES:



## Chapter 1. Overview

### 1.1 INTRODUCTION

The dsPIC33EP128GS806 Digital Power Plug-In Module (DP PIM) is a demonstration board that showcases the Microchip dsPIC33EP128GS806 16-Bit Digital Signal Controller (DSC) features. The DP PIM provides access to the dsPIC33EP128GS806 analog inputs, the Digital-to-Analog Converter (DAC) outputs, the Pulse-Width Modulation (PWM) outputs and the General Purpose Input and Output (GPIO) ports. The Microchip series of DP PIMs for digital power share the same pinout at the mating socket. However, these DP PIMs show slightly different performing characteristics.

### 1.2 FEATURES

The dsPIC33EP128GS806 DP PIM has the following features, as shown in [Figure 1-1](#):

**FIGURE 1-1: dsPIC33EP128GS806 DP PIM**

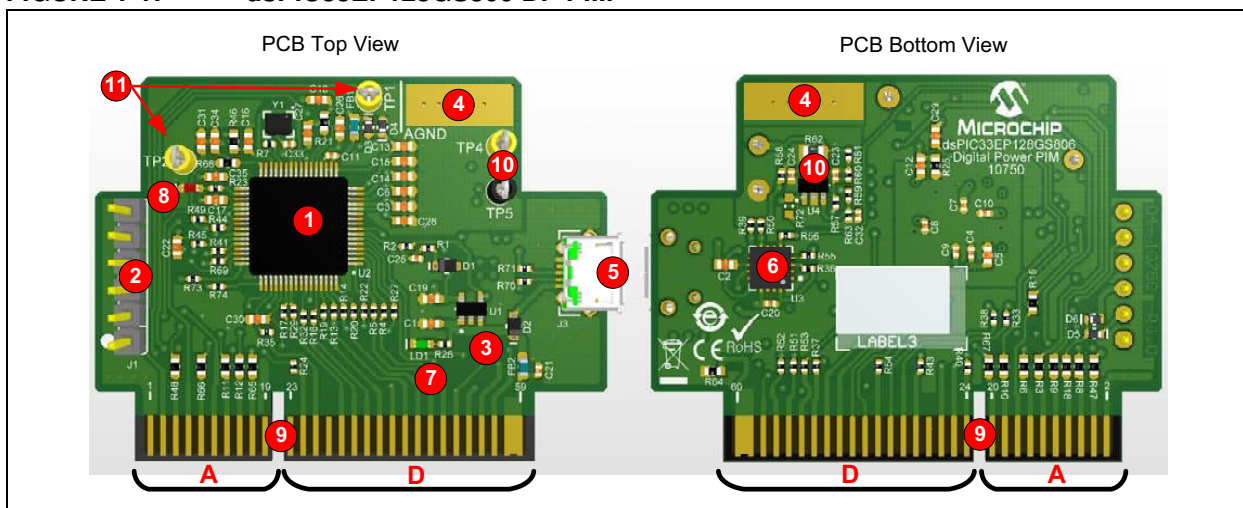

1. Microchip dsPIC33EP128GS806 16-Bit Digital Signal Controller (64-pin TQFP package).
2. ICSP™ programming header (6-pin, 2.54 mm header).
3. On-board LDO (3.6 VDC to 6.3 VDC) with Power Good (PG) function.
4. Solder pad for ground connection.
5. Micro USB connector.
6. MCP2221A USB to UART/I<sup>2</sup>C serial converter.
7. Power indicator LED (Green).
8. User LED (Red).
9. Board edge connection interface for analog inputs/outputs, PWM outputs and GPIO ports.
10. Analog input with op amp buffer via test point loop connector; can be used for Bode plot measurements.
11. Test point loops for DAC outputs.

Board dimensions are: 51 mm (length) x 38.5 mm (width).

## 1.2.1 Electrical Characteristics

Table 1-1 shows the electrical characteristics of the dsPIC33EP128GS806 DP PIM.

**TABLE 1-1: ELECTRICAL CHARACTERISTICS**

Parameter	Value
Input Voltage Range	3.6 VDC to 6.3 VDC
Current Consumption	<100 mA
Power Dissipation	<0.6W max.
Operating Temperature Range	-40°C to +85°C

## 1.2.2 Analog and Digital Signals

The dsPIC33EP128GS806 DP PIM ensures good signal integrity and provides all signals needed to control a power train. These signals are divided into two main sections: Analog, marked with A, and Digital, marked with D (see Figure 1-1):

### 1. Analog Section

The analog section is located at the left connector side (smaller section in Figure 1-1). It consists of 17 signals, all referenced to analog ground. These lines are split into four subsections:

- High-Speed Comparator Inputs: RC filtered with corner frequency of 10 MHz and maximum signal rise/fall time of 33 ns. These lines are designed to be used with on-chip comparators for signal zero-cross detections, etc.
- High-Speed ADC Inputs: RC filtered with corner frequency of 2 MHz and maximum signal rise/fall time of 180 ns. These lines are connected to the Track-and-Hold (T&H) circuitry of the dedicated ADC inputs and to the Sample-and-Hold (S&H) circuitry of the shared ADC inputs.
- Medium Speed ADC Inputs: RC filtered with corner frequency of 190 kHz and maximum signal rise/fall time of 1.8  $\mu$ s. These lines are connected to the Sample-and-Hold (S&H) circuitry of the shared ADC inputs. The different RC filtering is needed because of the significant difference between T&H and S&H circuitry, and the sampling times.
- DAC Output(s): These line(s) have a 560 Ohm series resistance. Please note that there is a capacitor placeholder on the board that can be used for additional filtering.

### 2. Digital Section

The digital section is located at the right connector side (larger section in Figure 1-1). It consists of 31 signals, all referenced to digital ground. These lines are split into four subsections:

- High-Speed PWM Outputs: Each line has a 75 $\Omega$  series resistance.
- Medium Speed GPIO: Each line has a 270 $\Omega$  series resistance.
- Programming/Debugging Lines: Each line has a 100 $\Omega$  series resistance.
- Communication Lines (SPI, I<sup>2</sup>C): Each line has a 75 $\Omega$  series resistance.

**Note:** RC filtering and series resistance are needed for good signal integrity and EMI issues. Hence, the board can be used for development purposes under frequent plug-in/out cycles. This decoupling also increases robustness in case of accidental shorts and EMC issues.

## 1.2.3 dsPIC33EP128GS806 DP PIM – PCB Edge Connector

The dsPIC33EP128GS806 DP PIM card has an edge connector compatible with any application board that provides a mating socket.

The mating socket type is Samtec, Inc.: MECF-30-01-L-DV-WT.

---

---

### 1.3 UART COMMUNICATION

The on-board USB to UART serial bridge enables easy serial connection to PCs. The USB port can provide power to the Digital Power PIM and allows the user to communicate with the dsPIC<sup>®</sup> Digital Signal Controller (DSC).

### 1.4 LOW-FREQUENCY BODE PLOT MEASUREMENTS

The dsPIC33EP128GS806 device, with the additional on-board circuitry, is able to perform Bode plot measurements without the need for an isolation transformer. The transformer might be required if the injecting signal tends to be at a very low frequency (for instance, in case of Power Factor Correction (PFC) applications).

Perform the following steps:

1. Solder the R72 (0 $\Omega$ ) resistor. Make sure that the AN5 line is not used by another low-impedance source.
2. Run the power stage in Open-Loop mode with a fixed duty cycle.
3. Connect the Bode 100 AC output to TP4 and TP5. The on-board operational amplifier is adding a  $V_{DD}/2$  (1.65V) offset. In this case, no injection transformer is needed anymore.
4. Connect DAC1 to CH2 and DAC2 to CH1 of the Bode 100.
5. Use the AN5 input to sample the signal from Bode 100 in every PWM cycle at Frequency Switching (FSW) (action in firmware is needed).
6. Remove the  $V_{DD}/2$  offset to regain a signal with no DC value (action in firmware is needed).
7. Add sampled AC signal to the nominal duty cycle (PDCx) (action in firmware is needed).
8. Use ADC2 to sample the output of the plant at FSW. The output can be:
  - Output voltage
  - Average coil current sampled at  $T_{ON}/2$ , where  $T_{ON}$  is the switch ON time.
9. Duty cycle input and plant output are converted into an analog signal using DAC1 and DAC2.

Measured transfer function is the plant (Power Stage + Digital Modulator) – after scaling and ADC sampling, versus digital duty cycle input (PDCx).

<p><b>Note:</b> Due to run-time delays of Sample-and-Hold circuits, and conversation time of ADC and DAC, this measurement is only recommended for low-frequency measurements: maximum two decades below sampling frequency.</p>
--

# dsPIC33EP128GS806 Digital Power PIM User's Guide

Figure 1-2 and Figure 1-3 show measuring procedure examples for plant and closed-loop measurements.

**FIGURE 1-2: MEASURING PROCEDURE FOR PLANT MEASUREMENT**

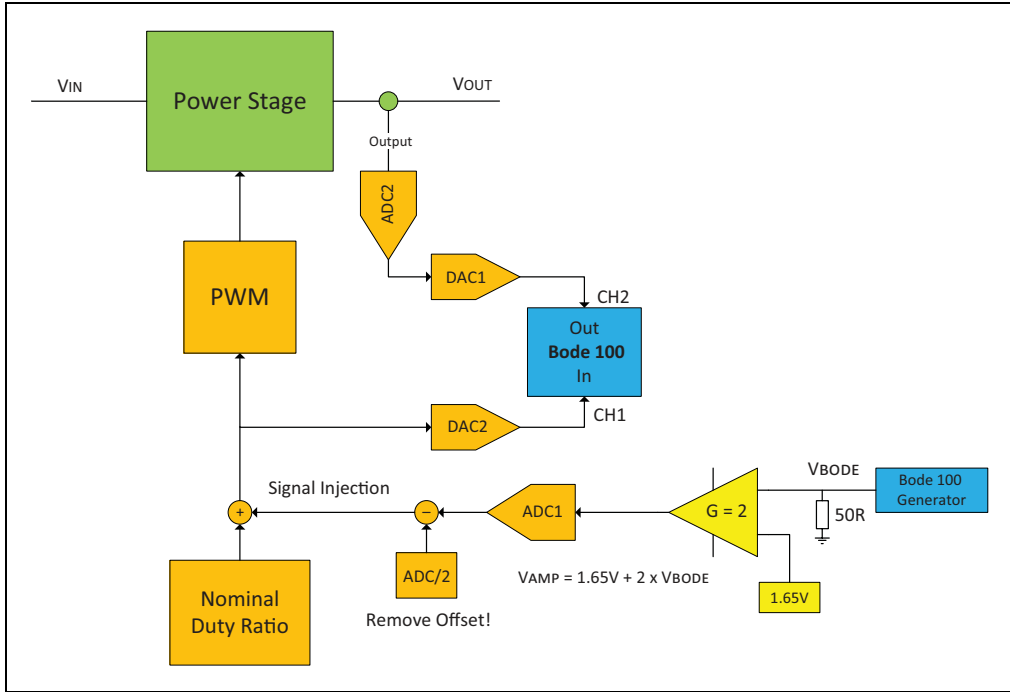

**FIGURE 1-3: MEASURING PROCEDURE FOR CLOSED-LOOP MEASUREMENT**

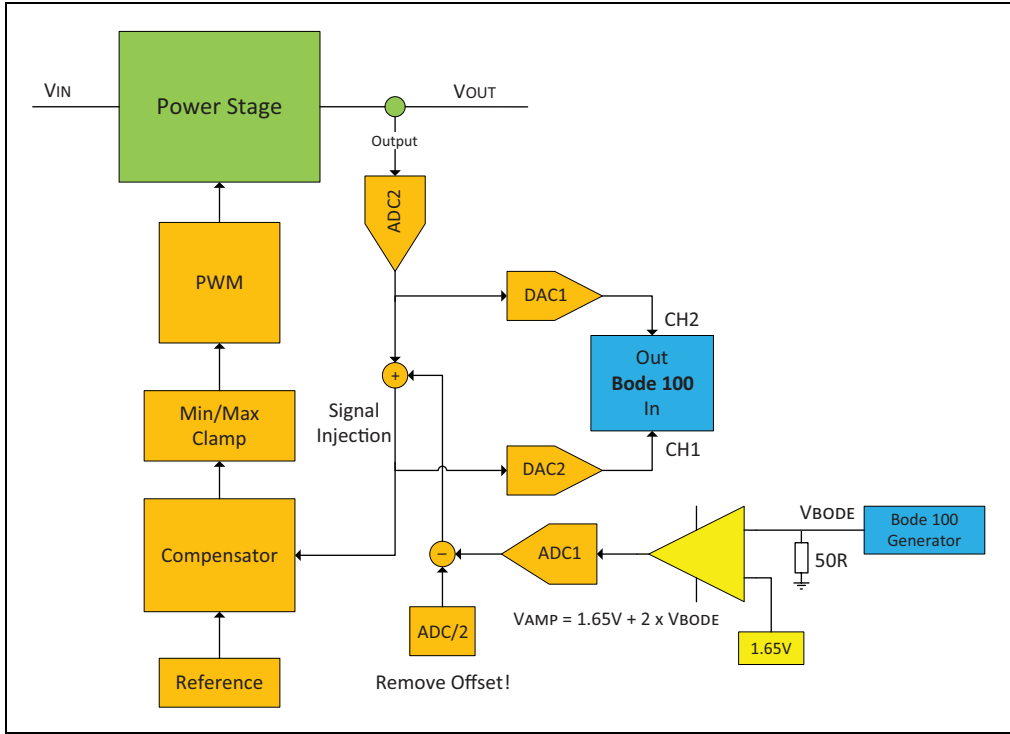

## Appendix A. Board Layout and Schematics

This appendix contains the pinout, the schematics and the board layouts for the dsPIC33EP128GS806 DP PIM.

- [Pinout](#)
- [Board Schematics](#)
- [PCB Layout](#)

### A.1 PINOUT

Pinout and electrical parameters are shown in [Table A-1](#).

**TABLE A-1: PINOUT AND ELECTRICAL PARAMETERS**

Name	Edge Connector Pin	Device Pin	Function/Description	Remark
GND_A	1	20	Analog Ground	Reserved for AGND connection
GND_A	2	20	Analog Ground	Reserved for AGND connection
RD13_DAC2_OUT	3	22	DAC Output	560R series resistance
RD7_AN15_IN	4	21	Analog Input, RC Filtered	$F_c = 190 \text{ kHz}$ , $t_r = 1.8 \mu\text{s}$
RC10_AN10_IN	5	24	Analog Input, RC Filtered	$F_c = 1.9 \text{ MHz}$ , $t_r = 180 \text{ ns}$
RA2_AN2_IN	6	15	Analog Input, RC Filtered	$F_c = 1.9 \text{ MHz}$ , $t_r = 180 \text{ ns}$
RB3_DAC1_OUT	7	32	DAC Output	560R series resistance
RC2_CMP_IN	8	35	Analog Input, RC Filtered	$F_c = 10 \text{ MHz}$ , $t_r = 33 \text{ ns}$
RC9_AN11_IN	9	23	Analog Input, RC Filtered	$F_c = 1.9 \text{ MHz}$ , $t_r = 180 \text{ ns}$
RB0_AN3_IN	10	16	Analog Input, RC Filtered	$F_c = 1.9 \text{ MHz}$ , $t_r = 180 \text{ ns}$
RD2_AN16_IN	11	30	Analog Input, RC Filtered	$F_c = 190 \text{ kHz}$ , $t_r = 1.8 \mu\text{s}$
RA0_AN0_IN	12	13	Analog Input, RC Filtered	$F_c = 1.9 \text{ MHz}$ , $t_r = 180 \text{ ns}$
RB2_AN7_IN	13	29	Analog Input, RC Filtered	$F_c = 1.9 \text{ MHz}$ , $t_r = 180 \text{ ns}$
RA1_AN1_IN	14	14	Analog Input, RC Filtered	$F_c = 1.9 \text{ MHz}$ , $t_r = 180 \text{ ns}$
RC1_AN8_IN	15	27	Analog Input, RC Filtered	$F_c = 1.9 \text{ MHz}$ , $t_r = 180 \text{ ns}$
RD8_AN5_IN	16	42	Analog Input, RC Filtered	$F_c = 190 \text{ kHz}$ , $t_r = 1.8 \mu\text{s}$
RC12_AN14_IN	17	12	Analog Input, RC Filtered	$F_c = 190 \text{ kHz}$ , $t_r = 1.8 \mu\text{s}$
RB9_CMP_IN	18	17	Analog Input, RC Filtered	$F_c = 10 \text{ MHz}$ , $t_r = 33 \text{ ns}$
—	19	—	—	—
RD5_AN12_IN	20	53	Analog Input, RC Filtered	$F_c = 190 \text{ kHz}$ , $t_r = 1.8 \mu\text{s}$
slot	slot	slot	slot	slot
slot	slot	slot	slot	slot
—	23	48	—	—
RC7_GPIO	24	36	Digital General Purpose SPI_MISO	270R series resistance

# dsPIC33EP128GS806 Digital Power PIM User's Guide

**TABLE A-1: PINOUT AND ELECTRICAL PARAMETERS (CONTINUED)**

Name	Edge Connector Pin	Device Pin	Function/Description	Remark
RD0_GPIO	25	47	Digital General Purpose	270R series resistance
RD14_GPIO	26	14	Digital General Purpose	270R series resistance
RC5_GPIO	27	51	Digital General Purpose	270R series resistance
RD9_GPIO	28	40	Digital General Purpose	270R series resistance
—	29	—	—	—
—	30	—	—	—
RD6_PWM5H	31	54	PWM Output	75R series resistance
RC8_GPIO	32	37	Digital General Purpose SPI_SCK	270R series resistance
RC3_PWM5L	33	55	PWM Output	75R series resistance
RC4_GPIO	34	50	Digital General Purpose	270R series resistance
RD4_GPIO	35	58	Digital General Purpose	270R series resistance
RC6_GPIO	36	52	Digital General Purpose SPI_MOSI	270R series resistance
RB11_PWM3H	37	60	PWM Output	75R series resistance
RD15_GPIO	38	59	Digital General Purpose	270R series resistance
RB5_GPIO19	39	46	Digital General Purpose	270R series resistance
RB14_PWM2L	40	63	PWM Output	75R series resistance
RB12_PWM3L	41	61	PWM Output	75R series resistance
RB13_PWM2H	42	13	PWM Output	75R series resistance
RD1_PWM4H	43	64	PWM Output	75R series resistance
RD3_PWM4L	44	1	PWM Output	75R series resistance
RA4_PWM1H	45	2	PWM Output	75R series resistance
RC0_GPIO	46	4	Digital General Purpose	270R series resistance
RA3_PWM1L	47	3	PWM Output	75R series resistance
RC13_GPIO	48	5	Digital General Purpose SPI_CS	270R series resistance
MCLR_IN	49	7	Reset	100R series resistance
RD12_GPIO	50	8	Digital General Purpose	270R series resistance
RB7_PGC	51	49	Programing/Debugging Line	100R series resistance
RD10_GPIO	52	6	Digital General Purpose	270R series resistance
RB15_SCL	53	44	I <sup>2</sup> C Clock Line	75R series resistance
RD11_GPIO	54	45	Digital General Purpose	270R series resistance
RB8_SDA	55	43	I <sup>2</sup> C Data Line	75R series resistance
RB6_PGD	56	48	Programing/Debugging Line	100R series resistance
5V	57	NA	VDD Rail	6.3V max, 70 mA max
GND_D	58	41, 25, 9	Digital Ground	—
5V	59	NA	VDD Rail	—
GND_D	60	41, 25, 9	Digital Ground	—

## A.2 BOARD SCHEMATICS

Figure A-1 and Figure A-2 show the board schematics.

### FIGURE A-1: dsPIC33EP128GS806 DIGITAL POWER PIM SCHEMATIC REV. 1.1 (PAGE 1 OF 2)

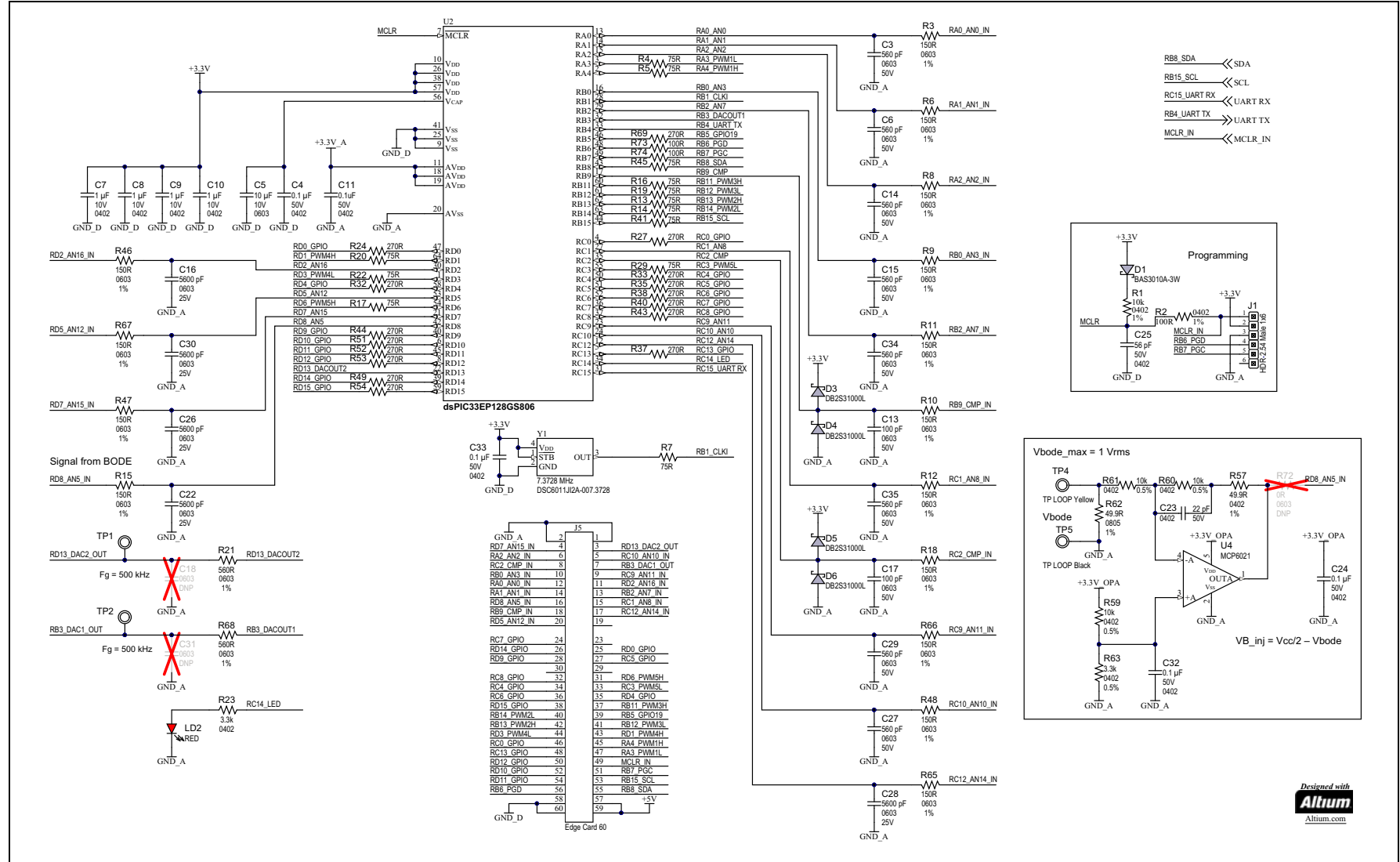
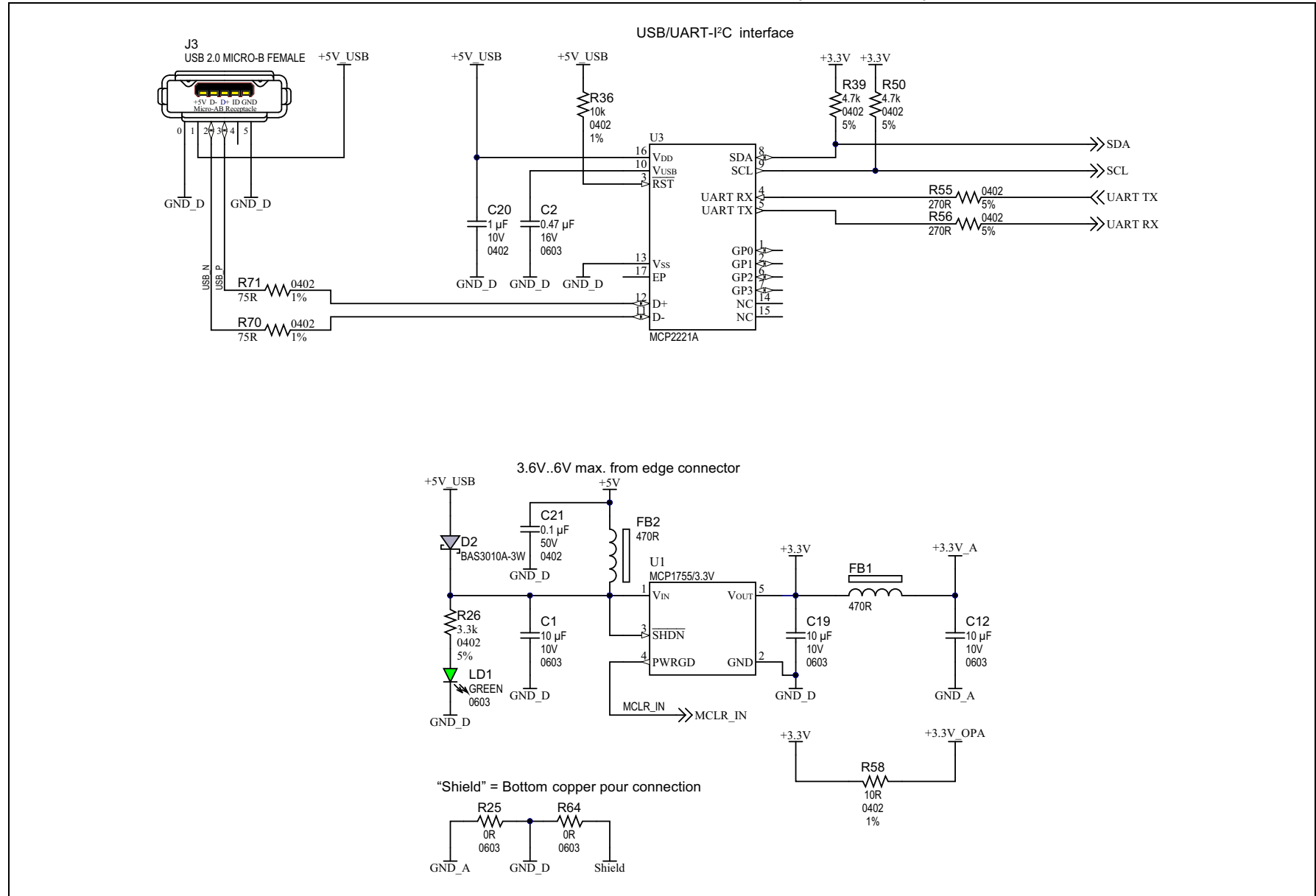

FIGURE A-2: dsPIC33EP128GS806 DIGITAL POWER PIM SCHEMATIC REV. 1.1 (PAGE 2 OF 2)





### A.3 PCB LAYOUT

The dsPIC33EP128GS806 DP PIM is a four-layer FR4, 1.55 mm, Plated Through-Hole (PTH) PCB construction. [Figure A-3](#) through [Figure A-5](#) illustrate the PCB layers and [Figure A-6](#) shows the assembly drawings of the dsPIC33EP128GS806 DP PIM.

**FIGURE A-3: dsPIC33EP128GS806 DIGITAL POWER PIM TOP SILKSCREEN AND TOP COPPER**

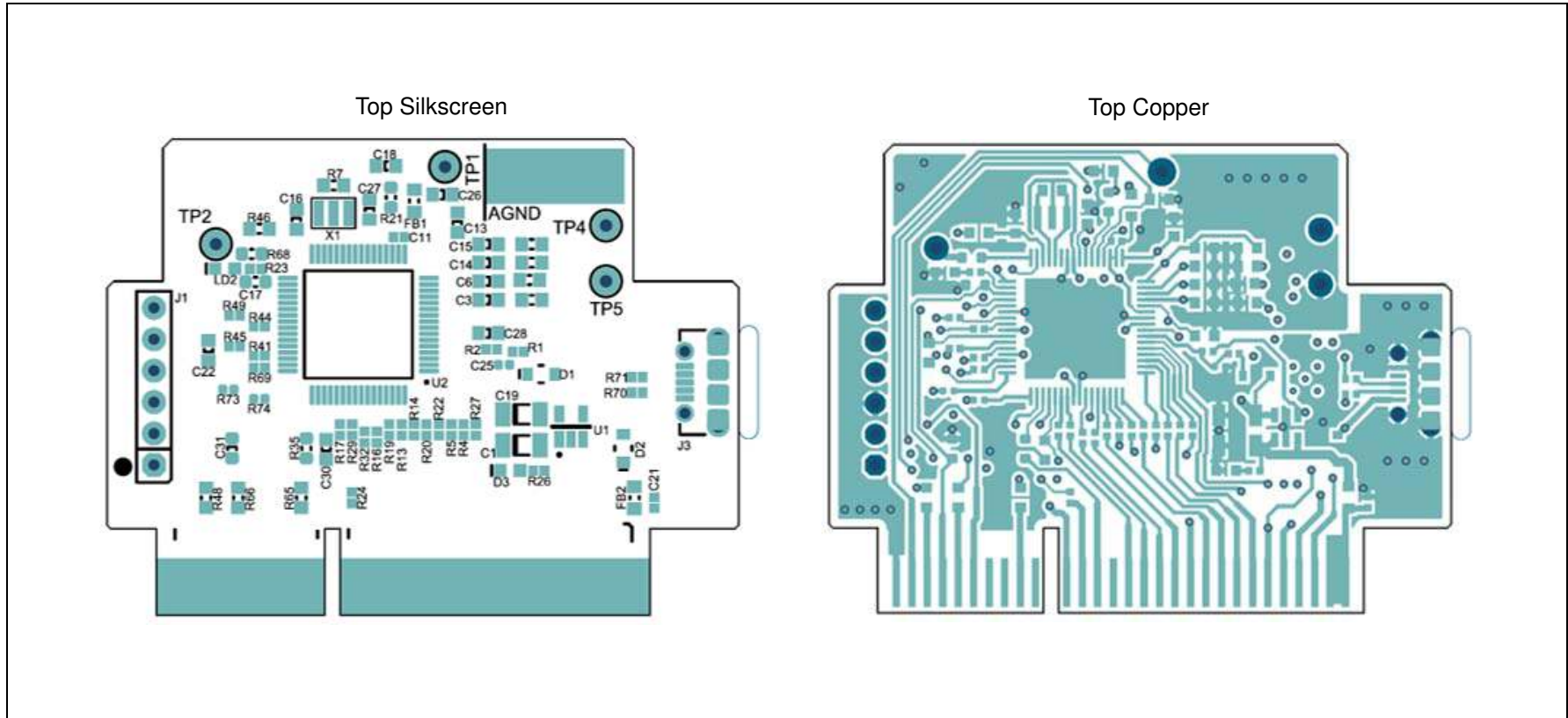

FIGURE A-4: dsPIC33EP128GS806 DIGITAL POWER PIM MID1 AND MID2 INNER COPPER (BOTTOM VIEW)

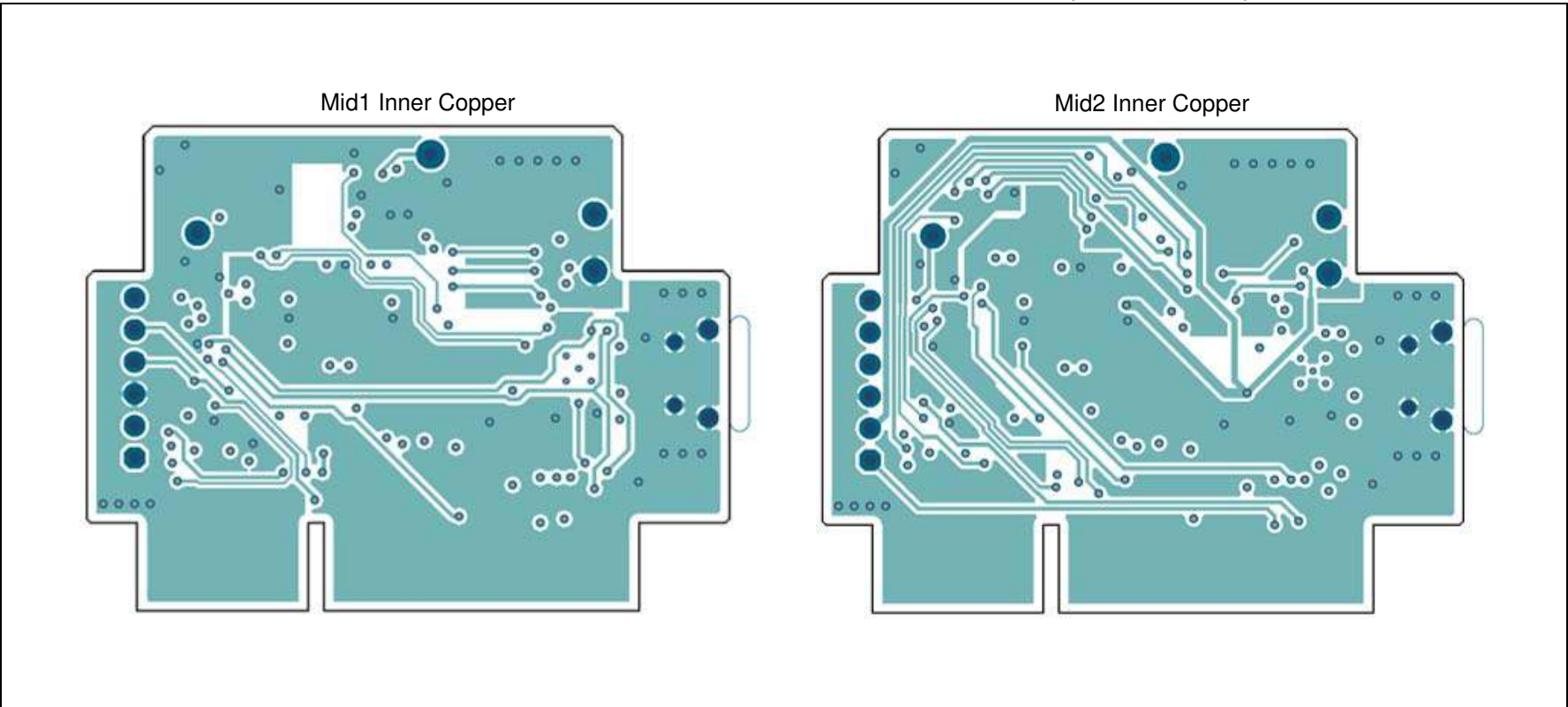

FIGURE A-5: dsPIC33EP128GS806 DIGITAL POWER PIM BOTTOM COPPER AND BOTTOM SILKSCREEN (BOTTOM VIEW)

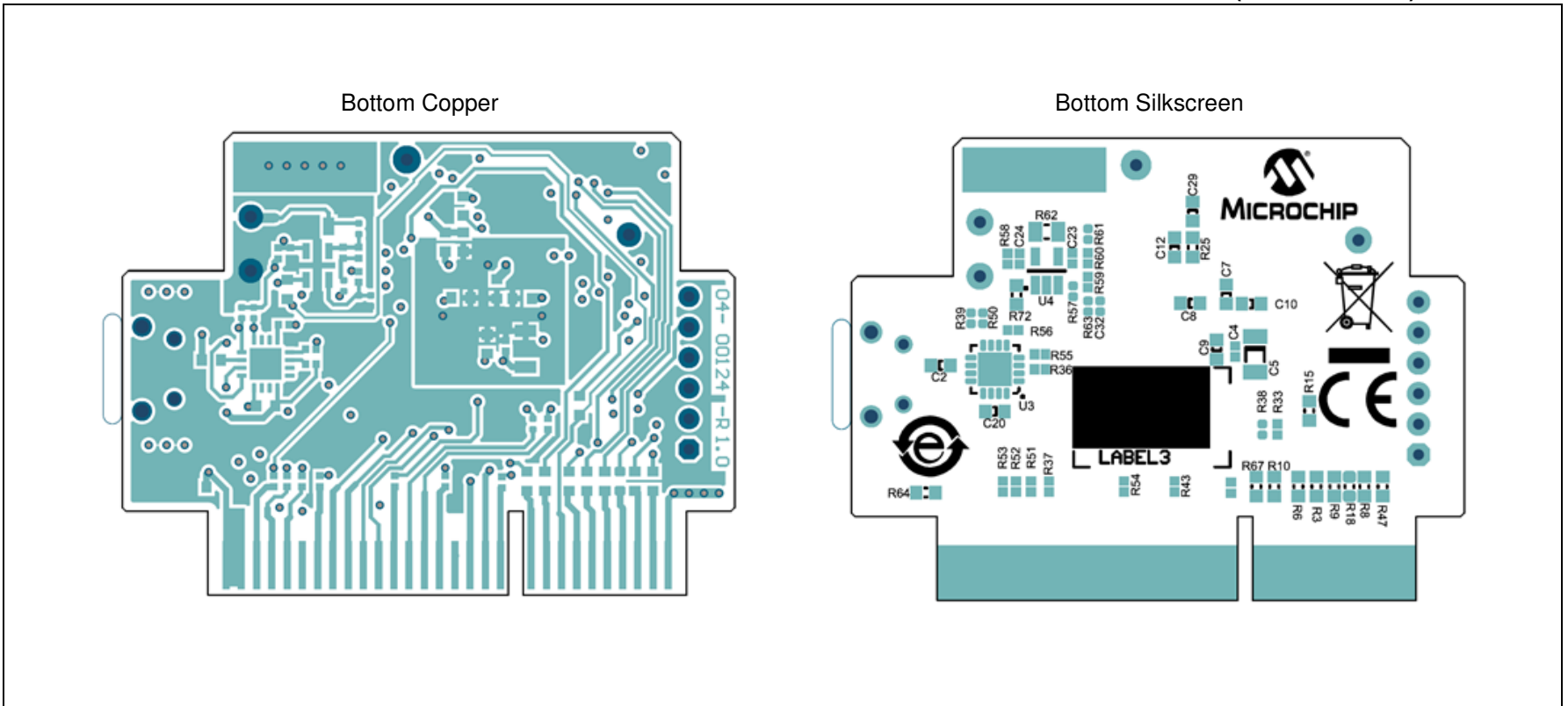
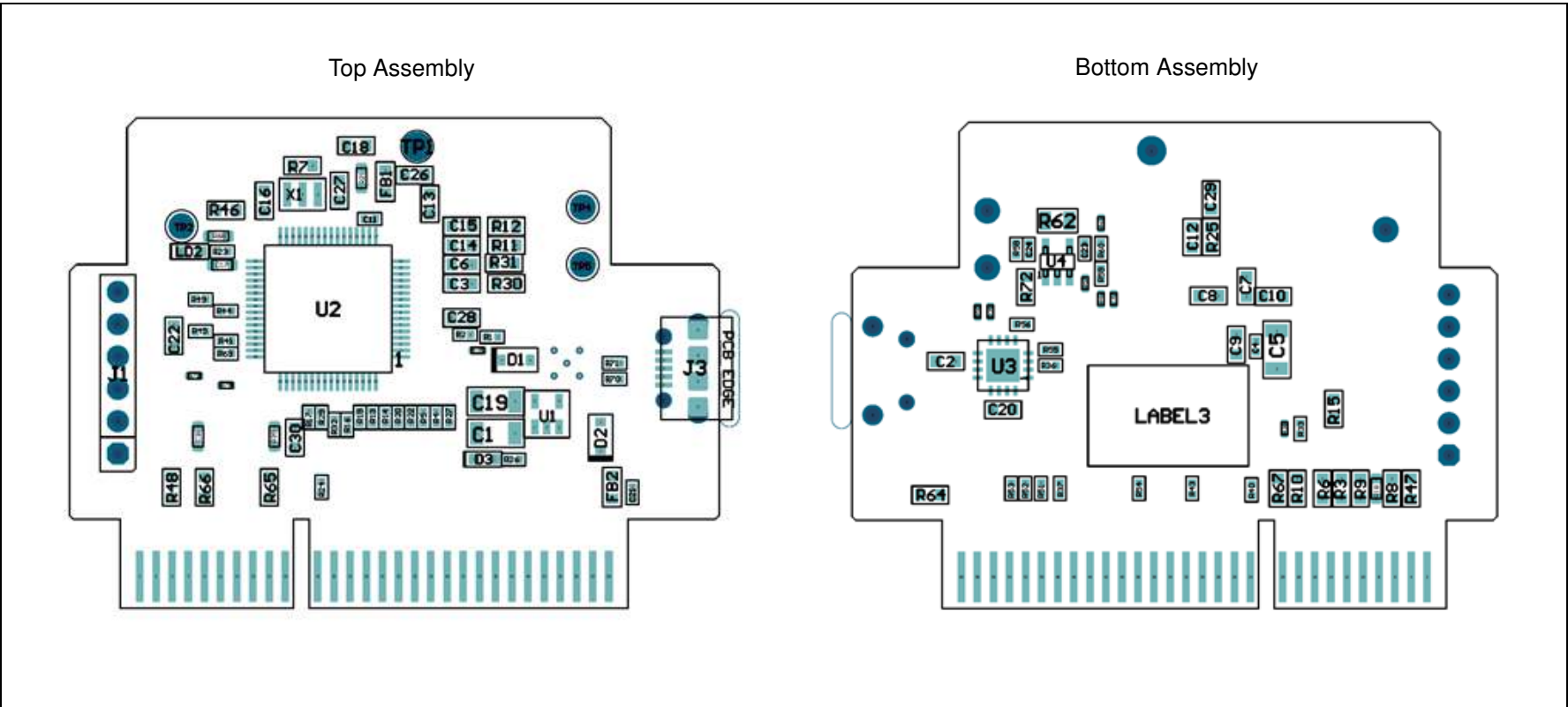

FIGURE A-6: dsPIC33EP128GS806 DIGITAL POWER PIM TOP AND BOTTOM ASSEMBLY



## Appendix B. Bill of Materials (BOM)

This appendix contains the Bill of Materials (BOM) for the dsPIC33EP128GS806 Digital Power PIM.

- [Bill of Materials](#)

### B.1 BILL OF MATERIALS

Table B-1 shows the Bill of Materials for the dsPIC33EP128GS806.

**TABLE B-1: dsPIC33EP128GS806 DIGITAL POWER PIM BILL OF MATERIALS**

Qty.	Designator	Description	Manufacturer	Manufacturer Part Number
4	C1, C5, C12, C19	Capacitor Ceramic, 10 $\mu$ F, 10V, 20%, X5R, SMD, 0603	Samsung Group	CL10A106MP8NNNC
1	C2	Capacitor Ceramic, 0.47 $\mu$ F, 16V, 10%, X7R, SMD, 0603	Murata Electronics®	GRM188R71C474KA88D
8	C3, C6, C14, C15, C27, C29, C34, C35	Capacitor Ceramic, 560 pF, 50V, 5%, C0G, NP0, SMD, 0603	KEMET	C0603C561J5GACTU
6	C4, C11, C21, C24, C32, C33	Capacitor Ceramic, 0.1 $\mu$ F, 50V, 10%, X7R, SMD, 0402	TDK Corporation	C1005X7R1H104K050BB
5	C7, C8, C9, C10, C20	Capacitor Ceramic, 1 $\mu$ F, 10V, 10%, X7S, SMD, 0402	TDK Corporation	C1005X7S1A105K050BC
2	C13, C17	Capacitor Ceramic, 100 pF, 50V, 5%, NP0, SMD, 0603	Cal-Chip Electronics Inc.	GMC10CG101J50NTLF
5	C16, C22, C26, C28, C30	Capacitor Ceramic, 5600 pF, 25V, 5%, C0G, SMD, 0603	TDK Corporation	C1608C0G1E562J080AA
1	C23	Capacitor HiQ, 22 pF, 50V, 5%, NP0, 1.95 GHz, SMD, 0402	Johanson Technology Inc.	500R07S220JV4T
1	C25	Capacitor Ceramic, 56 pF, 50V, 5%, C0G, SMD, 0402	TDK Corporation	C1005C0G1H560J050BA
2	D1, D2	Diode Schottky, BAS3010A-3W, 470 mV, 1A, 30V, SOD-323	Infineon Technologies AG	BAS3010A03WE6327HTSA1
4	D3, D4, D5, D6	Diode Schottky, DB2S31000L, 470 mV, 200 mA, 30V, SMD, SOD-523	Panasonic® Electronic Co.	DB2S31000L
2	FB1, FB2	Ferrite, 300 mA, 470R, SMD, 0603	Murata Electronics North America, Inc.	BLM18BB471SN1D
1	J1	Connector Header-2.54 Male, 1x6, Gold, 5.84MH, TH, Vertical	FCI	68000-106HLF
1	J3	Connector USB 2.0 micro-B Female, TH/SMD, R/A	FCI	10118194-0001LF

# dsPIC33EP128GS806 Digital Power PIM User's Guide

**TABLE B-1: dsPIC33EP128GS806 DIGITAL POWER PIM BILL OF MATERIALS (CONTINUED)**

Qty.	Designator	Description	Manufacturer	Manufacturer Part Number
1	LD1	Diode LED Green, 2V, 30 mA, 35 mcd, Clear, SMD, 0603	Lite-On®, Inc.	LTST-C190KGKT
1	LD2	Diode LED Red, 1.8V, 40 mA, 10 mcd, Clear, SMD, 0603	Lite-On, Inc.	LTST-C190KRKT
2	R1, R36	Resistor TKF, 10k, 1%, 1/10W, SMD, 0402	Panasonic Electronic Co.	ERJ-2RKF1002X
3	R2, R73, R74	Resistor TKF, 100R, 1%, 1/10W, SMD, 0402	Panasonic Electronic Co.	ERJ-2RKF1000X
15	R3, R6, R8, R9, R10, R11, R12, R15, R18, R46, R47, R48, R65, R66, R67	Resistor TKF, 150R, 1%, 1/10W, SMD, 0603	Stackpole Electronics, Inc.	RMCF0603FT150R
15	R4, R5, R7, R13, R14, R16, R17, R19, R20, R22, R29, R41, R45, R70, R71	Resistor TKF, 75R, 1%, 1/16W, SMD, 0402	Yageo Corporation	RC0402FR-0775RL
2	R21, R68	Resistor TKF, 560R, 1%, 1/10W, SMD, 0603	Yageo Corporation	RC0603FR-07560RL
2	R23, R26	Resistor TKF, 3.3k, 5%, 1/10W, SMD, 0402	Panasonic - ECG	ERJ-2GEJ332X
18	R24, R27, R32, R33, R35, R37, R38, R40, R43, R44, R49, R51, R52, R53, R54, R55, R56, R69	Resistor TKF, 270R, 5%, 1/10W, SMD, 0402	Panasonic - ECG	ERJ-2GEJ271X
2	R25, R64	Resistor TKF, 0R, 1/10W, SMD, 0603	NIC Components Corp.	NRC06Z0TRF
2	R39, R50	Resistor TKF, 4.7k, 5%, 1/10W, SMD, 0402	Panasonic - ECG	ERJ-2GEJ472X
1	R57	Resistor TKF, 49.9R, 1%, 1/16W, SMD, 0402	ROHM Semiconductor	MCR01MRTF49R9
1	R58	Resistor TKF, 10R, 1%, 1/16W, SMD, 0402	ROHM Semiconductor	MCR01MRTF10R0
3	R59, R60, R61	Resistor TKF, 10k, 0.5%, 1/16W, SMD, 0402	Susumu Co., Ltd.	RR0510P-103-D
1	R62	Resistor TKF, 49.9R, 1%, 1/8W, SMD 0805	Panasonic - ECG	ERJ-6ENF49R9V
1	R63	Resistor TKF, 3.3k, 0.5%, 1/16W, SMD, 0402	Panasonic Electronic Co.	ERA-2AED332X
3	TP1, TP2, TP4	Misc, Test Point PC Mini, 0.040", D, Yellow	Keystone Electronics Corp.	5004
1	TP5	Misc, Test Point Multipurpose Mini, Black	Keystone Electronics Corp.	5001

# Bill of Materials (BOM)

**TABLE B-1: dsPIC33EP128GS806 DIGITAL POWER PIM BILL OF MATERIALS (CONTINUED)**

Qty.	Designator	Description	Manufacturer	Manufacturer Part Number
<b>Microchip Parts</b>				
1	U1	Microchip Analog LDO, 3.3V, MCP1755T-3302E/OT, SOT-23-5	Microchip Technology Inc.	MCP1755T-3302E/OT
1	U2	Microchip MCU, 16-Bit, 120 MHz, 128K, 8K, dsPIC33EP128GS806, TQFP-64	Microchip Technology Inc.	dsPIC33EP128GS806-I/PT
1	U3	Microchip Interface, USB, I <sup>2</sup> C/UART, MCP2221A-I/ML, QFN-16	Microchip Technology Inc.	MCP2221A-I/ML
1	U4	Microchip Analog Op Amp, 1-Ch, 10 MHz, MCP6021T-E/OT, SOT-23-5	Microchip Technology Inc.	MCP6021T-E/OT
1	Y1	Microchip Clock Oscillator Single, 7.3728 MHz, DSC6011JI2A-007.3728, VDFN-4	Microchip Technology Inc.	DSC6011JI2A-007.3728
<b>Mechanical Parts</b>				
1	LABEL3	Label, AIPD Board Assembly	—	—
<b>PCB</b>				
1	PCB1	Printed Circuit Board	—	04-10750-R1.0
<b>Do Not Populate Parts</b>				
2	C18, C31	Capacitor Ceramic, 560 pF, 50V, 5%, C0G, NP0, SMD, 0603	KEMET	C0603C561J5GACTU
1	R72	Resistor TKF, 0R, 1/10W, SMD, 0603	NIC Components Corp.	NRC06Z0TRF





# MICROCHIP

## Worldwide Sales and Service

### AMERICAS

**Corporate Office**  
2355 West Chandler Blvd.  
Chandler, AZ 85224-6199  
Tel: 480-792-7200  
Fax: 480-792-7277  
Technical Support:  
<http://www.microchip.com/support>  
Web Address:  
[www.microchip.com](http://www.microchip.com)

#### Atlanta

Duluth, GA  
Tel: 678-957-9614  
Fax: 678-957-1455

#### Austin, TX

Tel: 512-257-3370

#### Boston

Westborough, MA  
Tel: 774-760-0087  
Fax: 774-760-0088

#### Chicago

Itasca, IL  
Tel: 630-285-0071  
Fax: 630-285-0075

#### Dallas

Addison, TX  
Tel: 972-818-7423  
Fax: 972-818-2924

#### Detroit

Novi, MI  
Tel: 248-848-4000

#### Houston, TX

Tel: 281-894-5983

#### Indianapolis

Noblesville, IN  
Tel: 317-773-8323  
Fax: 317-773-5453  
Tel: 317-536-2380

#### Los Angeles

Mission Viejo, CA  
Tel: 949-462-9523  
Fax: 949-462-9608  
Tel: 951-273-7800

#### Raleigh, NC

Tel: 919-844-7510

#### New York, NY

Tel: 631-435-6000

#### San Jose, CA

Tel: 408-735-9110  
Tel: 408-436-4270

#### Canada - Toronto

Tel: 905-695-1980  
Fax: 905-695-2078

### ASIA/PACIFIC

**Australia - Sydney**  
Tel: 61-2-9868-6733

**China - Beijing**  
Tel: 86-10-8569-7000

**China - Chengdu**  
Tel: 86-28-8665-5511

**China - Chongqing**  
Tel: 86-23-8980-9588

**China - Dongguan**  
Tel: 86-769-8702-9880

**China - Guangzhou**  
Tel: 86-20-8755-8029

**China - Hangzhou**  
Tel: 86-571-8792-8115

**China - Hong Kong SAR**  
Tel: 852-2943-5100

**China - Nanjing**  
Tel: 86-25-8473-2460

**China - Qingdao**  
Tel: 86-532-8502-7355

**China - Shanghai**  
Tel: 86-21-3326-8000

**China - Shenyang**  
Tel: 86-24-2334-2829

**China - Shenzhen**  
Tel: 86-755-8864-2200

**China - Suzhou**  
Tel: 86-186-6233-1526

**China - Wuhan**  
Tel: 86-27-5980-5300

**China - Xian**  
Tel: 86-29-8833-7252

**China - Xiamen**  
Tel: 86-592-2388138

**China - Zhuhai**  
Tel: 86-756-3210040

### ASIA/PACIFIC

**India - Bangalore**  
Tel: 91-80-3090-4444

**India - New Delhi**  
Tel: 91-11-4160-8631

**India - Pune**  
Tel: 91-20-4121-0141

**Japan - Osaka**  
Tel: 81-6-6152-7160

**Japan - Tokyo**  
Tel: 81-3-6880-3770

**Korea - Daegu**  
Tel: 82-53-744-4301

**Korea - Seoul**  
Tel: 82-2-554-7200

**Malaysia - Kuala Lumpur**  
Tel: 60-3-7651-7906

**Malaysia - Penang**  
Tel: 60-4-227-8870

**Philippines - Manila**  
Tel: 63-2-634-9065

**Singapore**  
Tel: 65-6334-8870

**Taiwan - Hsin Chu**  
Tel: 886-3-577-8366

**Taiwan - Kaohsiung**  
Tel: 886-7-213-7830

**Taiwan - Taipei**  
Tel: 886-2-2508-8600

**Thailand - Bangkok**  
Tel: 66-2-694-1351

**Vietnam - Ho Chi Minh**  
Tel: 84-28-5448-2100

### EUROPE

**Austria - Wels**  
Tel: 43-7242-2244-39  
Fax: 43-7242-2244-393

**Denmark - Copenhagen**  
Tel: 45-4450-2828  
Fax: 45-4485-2829

**Finland - Espoo**  
Tel: 358-9-4520-820

**France - Paris**  
Tel: 33-1-69-53-63-20  
Fax: 33-1-69-30-90-79

**Germany - Garching**  
Tel: 49-8931-9700

**Germany - Haan**  
Tel: 49-2129-3766400

**Germany - Heilbronn**  
Tel: 49-7131-67-3636

**Germany - Karlsruhe**  
Tel: 49-721-625370

**Germany - Munich**  
Tel: 49-89-627-144-0  
Fax: 49-89-627-144-44

**Germany - Rosenheim**  
Tel: 49-8031-354-560

**Israel - Ra'anana**  
Tel: 972-9-744-7705

**Italy - Milan**  
Tel: 39-0331-742611  
Fax: 39-0331-466781

**Italy - Padova**  
Tel: 39-049-7625286

**Netherlands - Drunen**  
Tel: 31-416-690399  
Fax: 31-416-690340

**Norway - Trondheim**  
Tel: 47-7289-7561

**Poland - Warsaw**  
Tel: 48-22-3325737

**Romania - Bucharest**  
Tel: 40-21-407-87-50

**Spain - Madrid**  
Tel: 34-91-708-08-90  
Fax: 34-91-708-08-91

**Sweden - Gothenberg**  
Tel: 46-31-704-60-40

**Sweden - Stockholm**  
Tel: 46-8-5090-4654

**UK - Wokingham**  
Tel: 44-118-921-5800  
Fax: 44-118-921-5820