

## DRV8842 DC Motor Driver IC

### 1 Features

- Single H-Bridge Current-Control Motor Driver
- 8.2-V to 45-V Operating Supply Voltage Range
- Five-Bit Winding Current Control Allows Up to 32 Current Levels
- Low MOSFET  $R_{DS(on)}$  Typical  $0.2\ \Omega$  (HS + LS)
- 5-A Maximum Drive Current at 24 V, 25°C
- Built-In 3.3-V Reference Output
- Industry-Standard PWM Control Interface
- Thermally Enhanced Surface Mount Package
- Protection Features:
  - Overcurrent Protection (OCP)
  - Thermal Shutdown (TSD)
  - VM Undervoltage Lockout (UVLO)
  - Fault Condition Indication Pin (nFAULT)

### 2 Applications

- Printers
- Scanners
- Office Automation Machines
- Gaming Machines
- Factory Automation
- Robotics

### 3 Description

The DRV8842 provides an integrated motor driver solution for printers, scanners, and other automated equipment applications. The device has one H-bridge driver, and is intended to drive one DC motor, one coil of a stepper motor, or other loads. The output driver block consists of N-channel power MOSFETs configured as an H-bridge. The DRV8842 can supply up to 5-A peak or 3.5-A RMS output current (with proper heatsinking at 24 V and 25°C).

Separate inputs to independently control each half of the H-bridge are provided.

Internal shutdown functions are provided for overcurrent protection, short-circuit protection, undervoltage lockout, and overtemperature.

The DRV8842 is available in a 28-pin HTSSOP package with PowerPAD™ (Eco-friendly: RoHS & no Sb/Br).

#### Device Information<sup>(1)</sup>

PART NUMBER	PACKAGE	BODY SIZE (NOM)
DRV8842	HTSSOP (28)	9.70 mm × 4.40 mm

(1) For all available packages, see the orderable addendum at the end of the datasheet.

#### Simplified Schematic

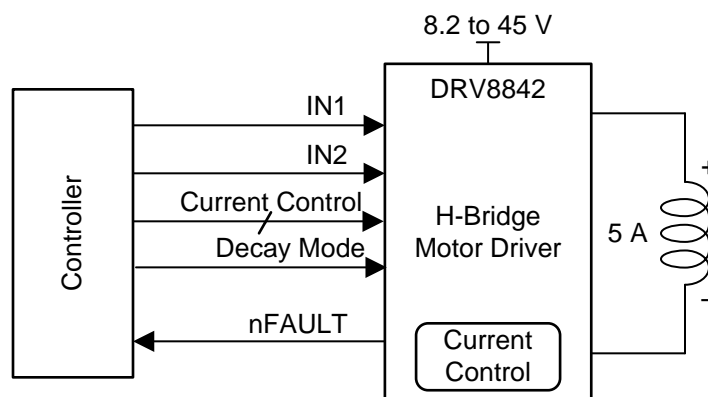

## Table of Contents

<b>1</b>	<b>Features</b> .....	<b>1</b>	<b>8</b>	<b>Application and Implementation</b> .....	<b>13</b>
<b>2</b>	<b>Applications</b> .....	<b>1</b>	8.1	Application Information.....	13
<b>3</b>	<b>Description</b> .....	<b>1</b>	8.2	Typical Application .....	13
<b>4</b>	<b>Revision History</b> .....	<b>2</b>	<b>9</b>	<b>Power Supply Recommendations</b> .....	<b>16</b>
<b>5</b>	<b>Pin Configuration and Functions</b> .....	<b>3</b>	9.1	Bulk Capacitance Sizing .....	16
<b>6</b>	<b>Specifications</b> .....	<b>4</b>	<b>10</b>	<b>Layout</b> .....	<b>17</b>
6.1	Absolute Maximum Ratings .....	4	10.1	Layout Guidelines .....	17
6.2	ESD Ratings.....	4	10.2	Layout Example .....	17
6.3	Recommended Operating Conditions.....	4	10.3	Thermal Considerations.....	18
6.4	Thermal Information .....	5	<b>11</b>	<b>Device and Documentation Support</b> .....	<b>19</b>
6.5	Electrical Characteristics.....	5	11.1	Documentation Support .....	19
6.6	Typical Characteristics.....	6	11.2	Community Resources.....	19
<b>7</b>	<b>Detailed Description</b> .....	<b>7</b>	11.3	Trademarks .....	19
7.1	Overview .....	7	11.4	Electrostatic Discharge Caution.....	19
7.2	Functional Block Diagram .....	8	11.5	Glossary .....	19
7.3	Feature Description.....	8	<b>12</b>	<b>Mechanical, Packaging, and Orderable Information</b> .....	<b>19</b>
7.4	Device Functional Modes.....	12			

## 4 Revision History

NOTE: Page numbers for previous revisions may differ from page numbers in the current version.

<b>Changes from Revision F (December 2015) to Revision G</b>	<b>Page</b>
• Changed the typical $R_{DS(on)}$ value from 0.65 $\Omega$ to 0.2 $\Omega$ in the <i>Features</i> section .....	1
• Changed ENBL and PHASE to IN1 and IN2 (respectively) in the <i>Simplified Schematic</i> , <i>Functional Block Diagram</i> , <i>Typical Application Schematic</i> , and <i>Example Layout</i> images .....	1

<b>Changes from Revision E (August 2013) to Revision F</b>	<b>Page</b>
• Added <i>ESD Ratings</i> table, <i>Feature Description</i> section, <i>Device Functional Modes</i> , <i>Application and Implementation</i> section, <i>Power Supply Recommendations</i> section, <i>Layout</i> section, <i>Device and Documentation Support</i> section, and <i>Mechanical, Packaging, and Orderable Information</i> section .....	1
• Added Protection Features and related list items to <i>Features</i> .....	1
• Changed the MIN value for ISENSEx pin voltage row from –0.3 V to –0.8 V.....	4

## 5 Pin Configuration and Functions

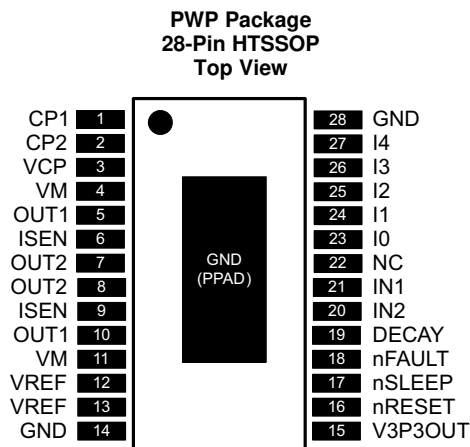

### Pin Functions

PIN		TYPE <sup>(1)</sup>	DESCRIPTION	EXTERNAL COMPONENTS OR CONNECTIONS
NAME	NO.			
<b>POWER AND GROUND</b>				
GND	14, 28	—	Device ground	
VM	4, 11	—	Bridge A power supply	Connect to motor supply (8.2 - 45 V). Both pins must be connected to same supply.
V3P3OUT	15	O	3.3-V regulator output	Bypass to GND with a 0.47- $\mu$ F, 6.3-V ceramic capacitor. Can be used to supply VREF.
CP1	1	IO	Charge pump flying capacitor	Connect a 0.01- $\mu$ F 50-V capacitor between CP1 and CP2.
CP2	2	IO	Charge pump flying capacitor	
VCP	3	IO	High-side gate drive voltage	Connect a 0.1- $\mu$ F 16-V ceramic capacitor and a 1-M $\Omega$ resistor to VM.
<b>CONTROL</b>				
IN1	21	I	Input 1	Logic input controls state of OUT1. Internal pull-down.
IN2	20	I	Input 2	Logic input controls state of OUT2. Internal pull-down.
I0	23	I	Current set inputs	Sets winding current as a percentage of full-scale. Internal pull-down.
I1	24	I		
I2	25	I		
I3	26	I		
I4	27	I		
DECAY	19	I	Decay mode	Low = slow decay, open = mixed decay, high = fast decay. Internal pull-down and pullup.
nRESET	16	I	Reset input	Active-low reset input initializes the logic and disables the H-bridge outputs. Internal pull-down.
nSLEEP	17	I	Sleep mode input	Logic high to enable device, logic low to enter low-power sleep mode. Internal pull-down.
VREF	12,13	I	Current set reference input	Reference voltage for winding current set. Both pins must be connected together on the PCB.
<b>STATUS</b>				
nFAULT	18	OD	Fault	Logic low when in fault condition (overtemperature, overcurrent)
<b>OUTPUT</b>				
ISEN	6, 9	IO	Bridge ground / Isense	Connect to current sense resistor. Both pins must be connected together on the PCB.

(1) Directions: I = input, O = output, OZ = tri-state output, OD = open-drain output, IO = input/output

**Pin Functions (continued)**

PIN		TYPE <sup>(1)</sup>	DESCRIPTION	EXTERNAL COMPONENTS OR CONNECTIONS
NAME	NO.			
OUT1	5, 10	O	Bridge output 1	Connect to motor winding. Both pins must be connected together on the PCB.
OUT2	7, 8	O	Bridge output 2	Connect to motor winding. Both pins must be connected together on the PCB.

**6 Specifications**

**6.1 Absolute Maximum Ratings**

over operating free-air temperature range (unless otherwise noted)<sup>(1)(2)</sup>

		MIN	MAX	UNIT
VM	Power supply voltage	-0.3	47	V
	Digital pin voltage	-0.5	7	V
VREF	Input voltage	-0.3	4	V
	ISENSEx pin voltage <sup>(3)</sup>	-0.8	0.8	V
	Peak motor drive output current, t < 1 μS	Internally limited		A
	Continuous motor drive output current <sup>(4)</sup>	0	5	A
	Continuous total power dissipation	See <a href="#">Thermal Information</a>		
T <sub>J</sub>	Operating virtual junction temperature	-40	150	°C
T <sub>A</sub>	Operating ambient temperature	-40	85	°C
T <sub>stg</sub>	Storage temperature	-60	150	°C

- (1) Stresses beyond those listed under *Absolute Maximum Ratings* may cause permanent damage to the device. These are stress ratings only, and functional operation of the device at these or any other conditions beyond those indicated under *Recommended Operating Conditions* is not implied. Exposure to absolute-maximum-rated conditions for extended periods may affect device reliability.
- (2) All voltage values are with respect to network ground pin.
- (3) Transients of ±1 V for less than 25 ns are acceptable
- (4) Power dissipation and thermal limits must be observed.

**6.2 ESD Ratings**

		VALUE	UNIT
V <sub>(ESD)</sub>	Electrostatic discharge		
	Human body model (HBM), per ANSI/ESDA/JEDEC JS-001, all pins <sup>(1)</sup>	±2000	V
Charged device model (CDM), per JEDEC specification JESD22-C101, all pins <sup>(2)</sup>	±500		

- (1) JEDEC document JEP155 states that 500-V HBM allows safe manufacturing with a standard ESD control process.
- (2) JEDEC document JEP157 states that 250-V CDM allows safe manufacturing with a standard ESD control process.

**6.3 Recommended Operating Conditions**

over operating free-air temperature range (unless otherwise noted)

		MIN	MAX	UNIT
V <sub>M</sub>	Motor power supply voltage <sup>(1)</sup>	8.2	45	V
V <sub>REF</sub>	VREF input voltage <sup>(2)</sup>	1	3.5	V
I <sub>V3P3</sub>	V3P3OUT load current	0	1	mA
f <sub>PWM</sub>	Externally applied PWM frequency	0	100	kHz

- (1) All V<sub>M</sub> pins must be connected to the same supply voltage.
- (2) Operational at VREF between 0 V and 1 V, but accuracy is degraded.

## 6.4 Thermal Information

THERMAL METRIC <sup>(1)</sup>		DRV8842		UNIT
		PWP (HTSSOP)		
		28 PINS		
R <sub>θJA</sub>	Junction-to-ambient thermal resistance	31.6		°C/W
R <sub>θJC(top)</sub>	Junction-to-case (top) thermal resistance	15.9		°C/W
R <sub>θJB</sub>	Junction-to-board thermal resistance	5.6		°C/W
ψ <sub>JT</sub>	Junction-to-top characterization parameter	0.2		°C/W
ψ <sub>JB</sub>	Junction-to-board characterization parameter	5.5		°C/W
R <sub>θJC(bot)</sub>	Junction-to-case (bottom) thermal resistance	1.4		°C/W

(1) For more information about traditional and new thermal metrics, see the *Semiconductor and IC Package Thermal Metrics* application report, [SPRA953](#).

## 6.5 Electrical Characteristics

over operating free-air temperature range (unless otherwise noted)

PARAMETER		TEST CONDITIONS	MIN	TYP	MAX	UNIT
<b>POWER SUPPLIES</b>						
I <sub>VM</sub>	VM operating supply current	V <sub>M</sub> = 24 V, f <sub>PWM</sub> < 50 kHz		5	8	mA
I <sub>VMQ</sub>	VM sleep mode supply current	V <sub>M</sub> = 24 V		10	20	μA
V <sub>UVLO</sub>	VM undervoltage lockout voltage	V <sub>M</sub> rising		7.8	8.2	V
<b>V3P3OUT REGULATOR</b>						
V <sub>3P3</sub>	V3P3OUT voltage	I <sub>OUT</sub> = 0 mA to 1 mA	3.2	3.3	3.4	V
<b>LOGIC-LEVEL INPUTS</b>						
V <sub>IL</sub>	Input low voltage			0.6	0.7	V
V <sub>IH</sub>	Input high voltage		2.2		5.25	V
V <sub>HYS</sub>	Input hysteresis		0.3	0.45	0.6	V
I <sub>IL</sub>	Input low current	V <sub>IN</sub> = 0	-20		20	μA
I <sub>IH</sub>	Input high current	V <sub>IN</sub> = 3.3 V		33	100	μA
R <sub>PD</sub>	Internal pulldown resistance			100		kΩ
<b>nFAULT OUTPUT (OPEN-DRAIN OUTPUT)</b>						
V <sub>OL</sub>	Output low voltage	I <sub>O</sub> = 5 mA			0.5	V
I <sub>OH</sub>	Output high leakage current	V <sub>O</sub> = 3.3 V			1	μA
<b>DECAY INPUT</b>						
V <sub>IL</sub>	Input low threshold voltage	For slow decay (brake) mode	0		0.8	V
V <sub>IH</sub>	Input high threshold voltage	For fast decay (coast) mode	2			V
I <sub>IN</sub>	Input current				±40	μA
R <sub>PU</sub>	Internal pullup resistance (to 3.3 V)			130		kΩ
R <sub>PD</sub>	Internal pulldown resistance			80		kΩ
<b>H-BRIDGE FETS</b>						
R <sub>DS(ON)</sub>	HS FET on resistance	V <sub>M</sub> = 24 V, I <sub>O</sub> = 1 A, T <sub>J</sub> = 25°C		0.1		Ω
		V <sub>M</sub> = 24 V, I <sub>O</sub> = 1 A, T <sub>J</sub> = 85°C		0.13	0.16	
R <sub>DS(ON)</sub>	LS FET on resistance	V <sub>M</sub> = 24 V, I <sub>O</sub> = 1 A, T <sub>J</sub> = 25°C		0.1		Ω
		V <sub>M</sub> = 24 V, I <sub>O</sub> = 1 A, T <sub>J</sub> = 85°C		0.13	0.16	
I <sub>OFF</sub>	Off-state leakage current		-40		40	μA
<b>MOTOR DRIVER</b>						
f <sub>PWM</sub>	Internal current control PWM frequency			50		kHz
t <sub>BLANK</sub>	Current sense blanking time			3.75		μs
t <sub>R</sub>	Rise time		30		200	ns
t <sub>F</sub>	Fall time		30		200	ns

### Electrical Characteristics (continued)

over operating free-air temperature range (unless otherwise noted)

PARAMETER		TEST CONDITIONS	MIN	TYP	MAX	UNIT
<b>PROTECTION CIRCUITS</b>						
$I_{OCP}$	Overcurrent protection trip level		6			A
$t_{TSD}$	Thermal shutdown temperature	Die temperature	150	160	180	°C
<b>CURRENT CONTROL</b>						
$I_{REF}$	VREF input current	VREF = 3.3 V	-3		3	μA
$V_{TRIP}$	ISENSE trip voltage	VREF = 3.3 V, 100% current setting	635	660	685	mV
$\Delta I_{TRIP}$	Current trip accuracy (relative to programmed value)	VREF = 3.3 V, 5% current setting	-25%		25%	
		VREF = 3.3 V, 10% to 34% current setting	-15%		15%	
		VREF = 3.3 V, 38% to 67% current setting	-10%		10%	
		VREF = 3.3 V, 71% to 100% current setting	-5%		5%	
$A_{ISENSE}$	Current sense amplifier gain	Reference only		5		V/V

### 6.6 Typical Characteristics

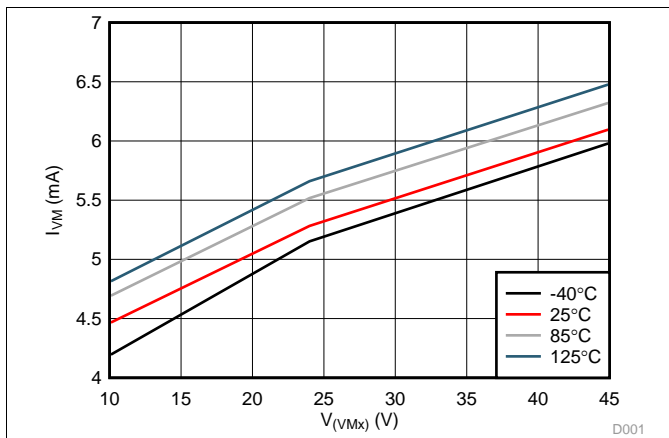

Figure 1.  $I_{VMX}$  vs  $V_{VMX}$

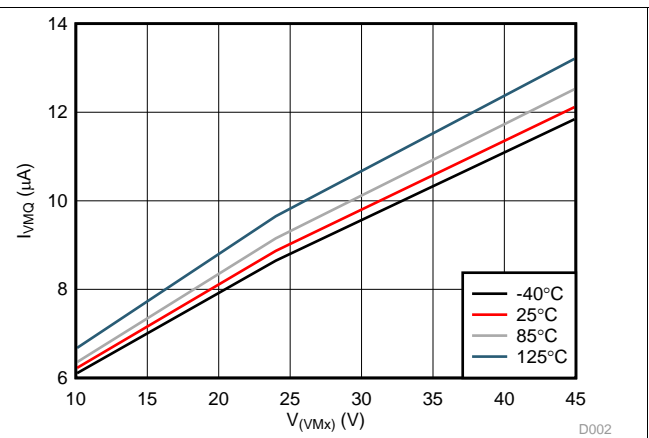

Figure 2.  $I_{VMXQ}$  vs  $V_{VMX}$

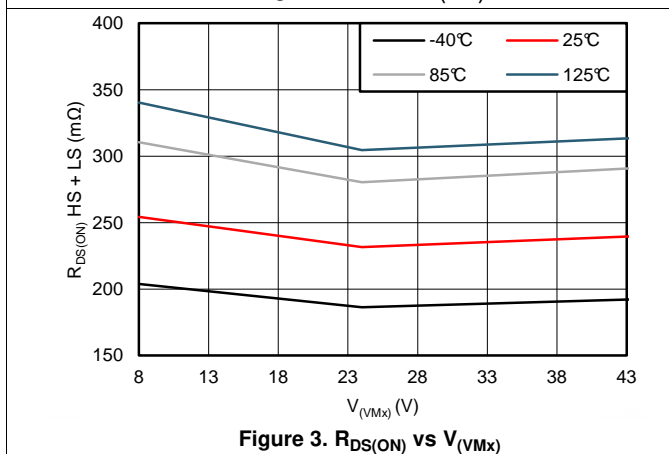

Figure 3.  $R_{DS(ON)}$  vs  $V_{VMX}$

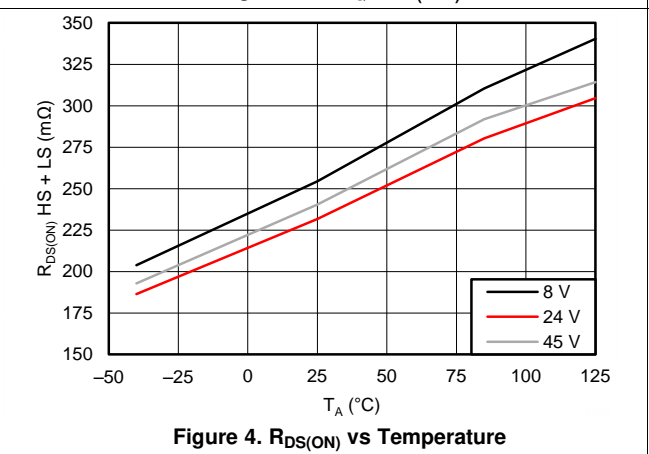

Figure 4.  $R_{DS(ON)}$  vs Temperature

## 7 Detailed Description

### 7.1 Overview

The DRV8842 device is an integrated motor driver solution for printers, scanners, and other automated equipment applications. The device integrates a single NMOS H-bridge, charge pump, current sense, current regulation, and device protection circuitry. The DRV8842 device can be powered from a single voltage supply from 8.2 V to 45 V, and is capable of providing a continuous output current up to 5 A.

A simple PWM interface allows for easy interfacing to an external controller. A 5 bit current control scheme allows for up to 32 discrete current levels. The current regulation method is adjustable between slow, mixed, and fast decay.

The integrated protection circuits allow the device to monitor and protect against overcurrent, undervoltage, and overtemperature faults, which are all reported through a fault indication pin (nFAULT). A low-power sleep mode is integrated, which allows the system to lower power consumption when not driving the motor.





Feature Description (continued)

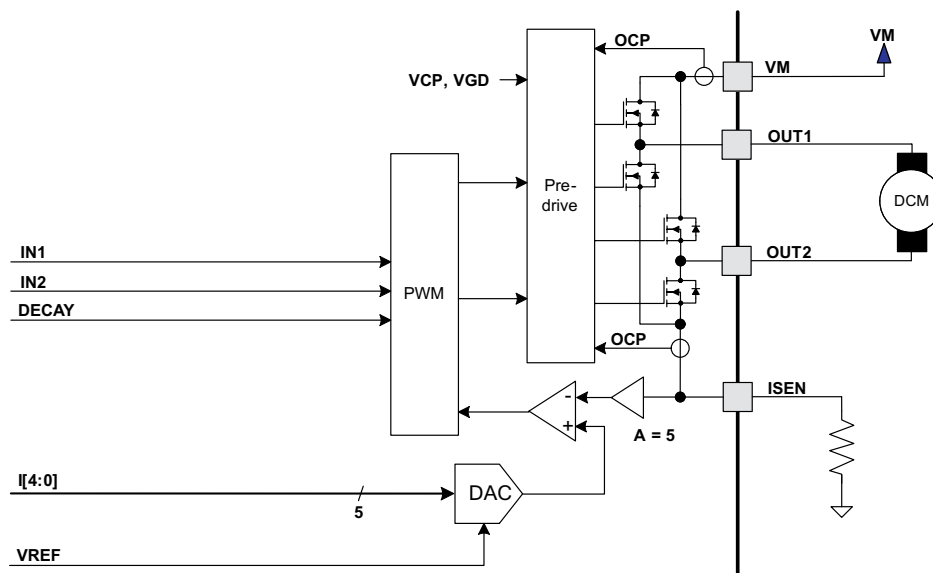

Figure 5. Motor Control Circuitry

Note that there are multiple VM, ISEN, OUT, and VREF pins. All like-named pins must be connected together on the PCB.

7.3.2 Bridge Control

The IN1 and IN2 input pins directly control the state of the OUT1 and OUT2 outputs. Either input can also be used for PWM control of the load. Table 1 shows the logic.

Table 1. H-Bridge Logic

xIN1	xIN2	xOUT1	xOUT2
0	0	L	L
0	1	L	H
1	0	H	L
1	1	H	H

The control inputs have internal pulldown resistors of approximately 100 kΩ.

7.3.3 Current Regulation

The maximum current through the load is regulated by a fixed-frequency PWM current regulation, or current chopping. When the H-bridge is enabled, current rises through the winding at a rate dependent on the DC voltage and inductance of the winding. Once the current hits the current chopping threshold, the bridge disables the current until the beginning of the next PWM cycle.

For DC motors, current regulation is used to limit the start-up and stall current of the motor. Speed control is typically performed by providing an external PWM signal to the xIN1 or xIN2 input pins.

If the current regulation feature is not needed, it can be disabled by connecting the ISENSE pins directly to ground and the VREF pins to V3P3.

The PWM chopping current is set by a comparator which compares the voltage across a current sense resistor connected to the ISEN pin, multiplied by a factor of 5, with a reference voltage. The reference voltage is input from the VREF pin, and is scaled by a 5-bit DAC that allows current settings of zero to 100% in an approximately sinusoidal sequence.

The full-scale (100%) chopping current is calculated in [Equation 1](#).

$$I_{\text{CHOP}} = \frac{V_{\text{REFX}}}{5 \times R_{\text{ISENSE}}} \quad (1)$$

Example:

If a 0.25-Ω sense resistor is used and the VREFx pin is 2.5 V, the full-scale (100%) chopping current will be 2.5 V / (5 x 0.25 Ω) = 2 A.

Five input pins (I0 - I4) are used to scale the current in the bridge as a percentage of the full-scale current set by the VREF input pin and sense resistance. The I0 - I4 pins have internal pulldown resistors of approximately 100 kΩ. The function of the pins is shown in [Table 2](#).

**Table 2. Pin Functions**

I[4..0]	RELATIVE CURRENT (% FULL-SCALE CHOPPING CURRENT)
0x00h	0%
0x01h	5%
0x02h	10%
0x03h	15%
0x04h	20%
0x05h	24%
0x06h	29%
0x07h	34%
0x08h	38%
0x09h	43%
0x0Ah	47%
0x0Bh	51%
0x0Ch	56%
0x0Dh	60%
0x0Eh	63%
0x0Fh	67%
0x10h	71%
0x11h	74%
0x12h	77%
0x13h	80%
0x14h	83%
0x15h	86%
0x16h	88%
0x17h	90%
0x18h	92%
0x19h	94%
0x1Ah	96%
0x1Bh	97%
0x1Ch	98%
0x1Dh	99%
0x1Eh	100%
0x1Fh	100%

### 7.3.4 Decay Mode

During PWM current chopping, the H-bridge is enabled to drive current through the motor winding until the PWM current chopping threshold is reached. This is shown in Figure 6 as case 1. The current flow direction shown indicates the state when the IN1 pin is high and the IN2 pin is low.

Once the chopping current threshold is reached, the H-bridge can operate in two different states, fast decay or slow decay.

In fast decay mode, once the PWM chopping current level has been reached, the H-bridge reverses state to allow winding current to flow in a reverse direction. As the winding current approaches zero, the bridge is disabled to prevent any reverse current flow. Fast decay mode is shown in Figure 6 as case 2.

In slow decay mode, winding current is re-circulated by enabling both of the low-side FETs in the bridge. This is shown in Figure 6 as case 3.

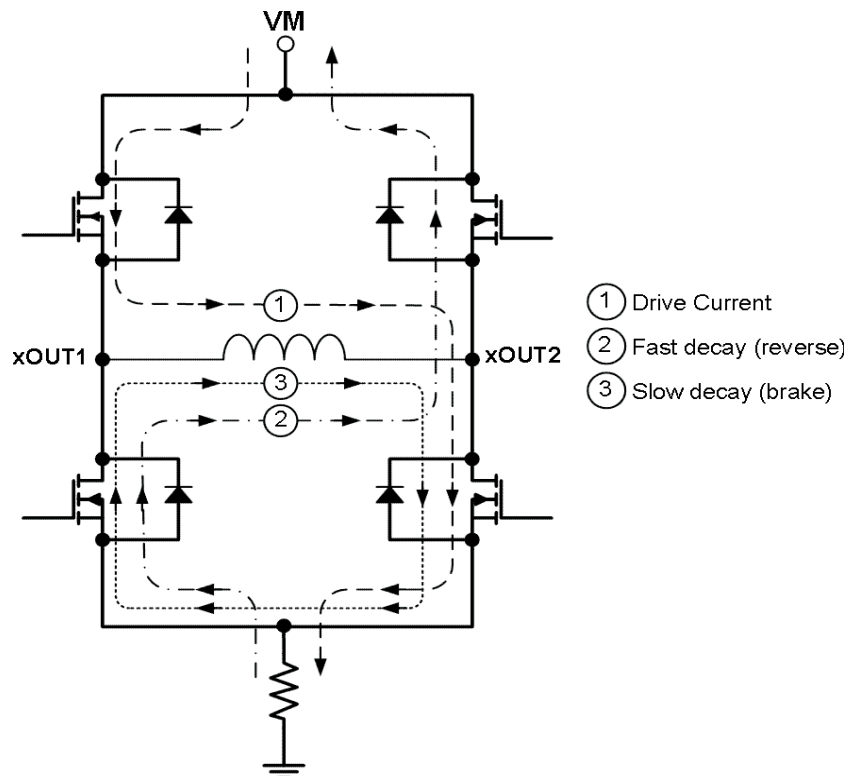

Figure 6. Decay Mode

The DRV8842 supports fast decay, slow decay and a mixed decay mode. Slow, fast, or mixed decay mode is selected by the state of the DECAY pin - logic low selects slow decay, open selects mixed decay operation, and logic high sets fast decay mode. The DECAY pin has both an internal pullup resistor of approximately 130 kΩ and an internal pulldown resistor of approximately 80 kΩ. This sets the mixed decay mode if the pin is left open or undriven.

Mixed decay mode begins as fast decay, but at a fixed period of time (75% of the PWM cycle) switches to slow decay mode for the remainder of the fixed PWM period.

### 7.3.5 Blanking Time

After the current is enabled in an H-bridge, the voltage on the xISEN pin is ignored for a fixed period of time before enabling the current sense circuitry. This blanking time is fixed at 3.75 μs. Note that the blanking time also sets the minimum on time of the PWM.

### 7.3.6 Protection Circuits

The DRV8842 device is fully protected against undervoltage, overcurrent and overtemperature events.

#### 7.3.6.1 Overcurrent Protection (OCP)

An analog current limit circuit on each FET limits the current through the FET by removing the gate drive. If this analog current limit persists for longer than the OCP time, all FETs in the H-bridge will be disabled and the nFAULT pin will be driven low. The device will remain disabled until either nRESET pin is applied, or VM is removed and re-applied.

Overcurrent conditions on both high and low side devices; i.e., a short to ground, supply, or across the motor winding will all result in an overcurrent shutdown. Overcurrent protection does not use the current sense circuitry used for PWM current control, and is independent of the  $I_{SENSE}$  resistor value or VREF voltage.

#### 7.3.6.2 Thermal Shutdown (TSD)

If the die temperature exceeds safe limits, all FETs in the H-bridge will be disabled and the nFAULT pin will be driven low. Once the die temperature has fallen to a safe level operation will automatically resume.

#### 7.3.6.3 Undervoltage Lockout (UVLO)

If at any time the voltage on the VM pins falls below the undervoltage lockout threshold voltage, all circuitry in the device will be disabled and internal logic will be reset. Operation will resume when  $V_M$  rises above the UVLO threshold.

## 7.4 Device Functional Modes

### 7.4.1 nRESET and nSLEEP Operation

The nRESET pin, when driven active low, resets the internal logic. It also disables the H-bridge driver. All inputs are ignored while nRESET is active.

Driving nSLEEP low will put the device into a low power sleep state. In this state, the H-bridges are disabled, the gate drive charge pump is stopped, the V3P3OUT regulator is disabled, and all internal clocks are stopped. In this state all inputs are ignored until nSLEEP returns inactive high. When returning from sleep mode, some time (approximately 1 ms) needs to pass before the motor driver becomes fully operational. Note that nRESET and nSLEEP have internal pulldown resistors of approximately 100 k $\Omega$ . These signals need to be driven to logic high for device operation.

## 8 Application and Implementation

### NOTE

Information in the following applications sections is not part of the TI component specification, and TI does not warrant its accuracy or completeness. TI's customers are responsible for determining suitability of components for their purposes. Customers should validate and test their design implementation to confirm system functionality.

### 8.1 Application Information

The DRV8842 device is used in brushed motor or stepper motor control. The onboard current regulation allows for limiting the motor current through simple pin configurations.

### 8.2 Typical Application

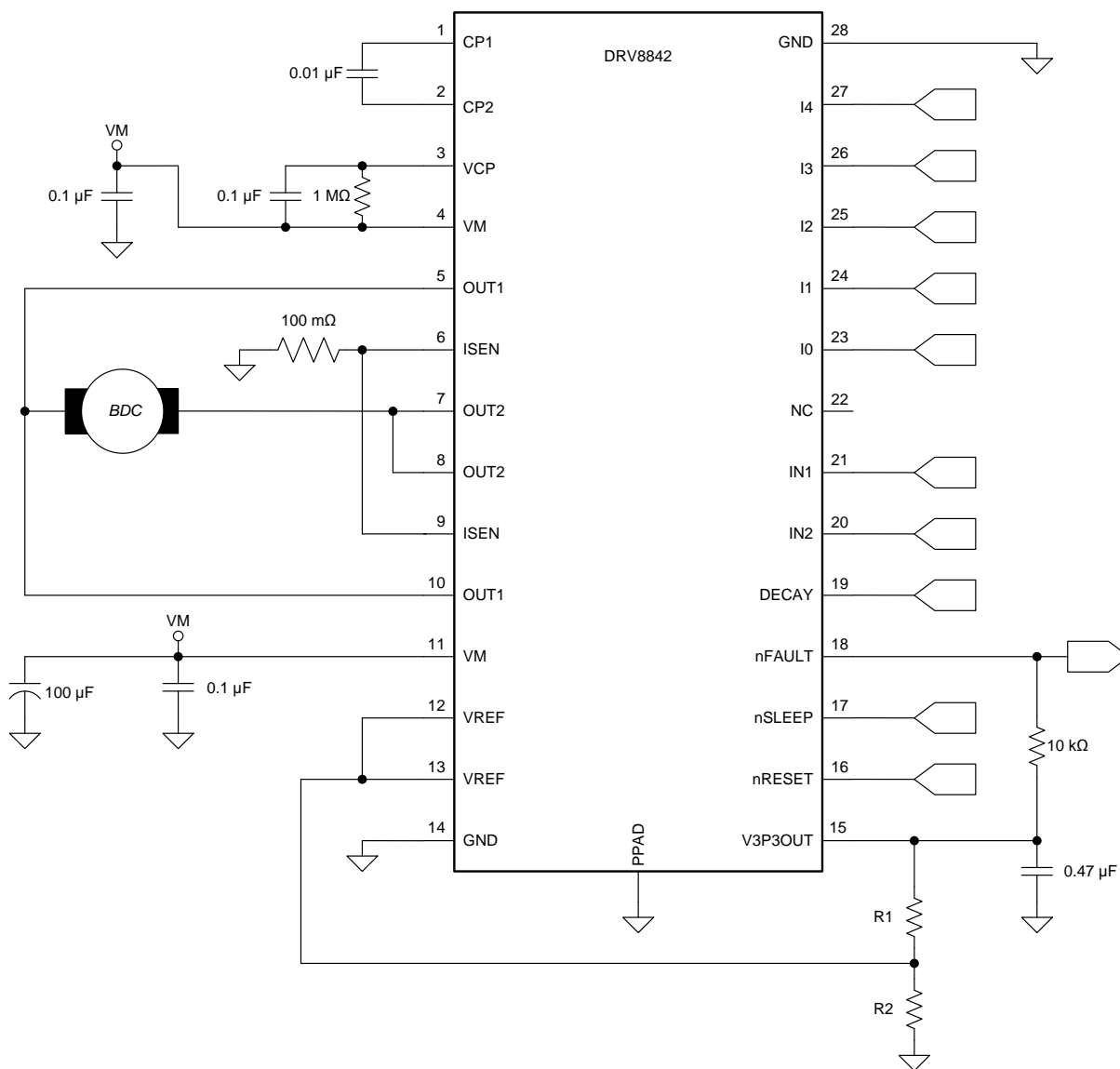

**Figure 7. Typical Application Schematic**

## Typical Application (continued)

### 8.2.1 Design Requirements

Table 3 shows the design parameters for this application.

**Table 3. Design Parameters**

DESIGN PARAMETER	REFERENCE	EXAMPLE VALUE
Supply Voltage	V <sub>M</sub>	24 V
Motor Winding Resistance	R <sub>M</sub>	3.9 Ω
Motor Winding Inductance	L <sub>M</sub>	2.9 mH
Target Chopping Current	I <sub>TRIP</sub>	1.5 A
Sense Resistor	R <sub>SENSE</sub>	100 mΩ
VREF Voltage	V <sub>REF</sub>	0.75 V

### 8.2.2 Detailed Design Procedure

#### 8.2.2.1 Current Regulation

The maximum current (I<sub>TRIP</sub>) is set by the I<sub>x</sub> pins, the VREF analog voltage, and the sense resistor value (R<sub>SENSE</sub>). When starting a brushed DC motor, a large inrush current may occur because there is no back-EMF and high detent torque. Current regulation will act to limit this inrush current and prevent high current on start-up.

$$I_{TRIP} = V_{REF} / (5 \times R_{SENSE}) \quad (2)$$

**Example:** If the desired chopping currents is 1.5 A:

- Set R<sub>SENSE</sub> = 100 mΩ
- VREF would have to be 0.75 V
- Create a resistor divider network from V3P3OUT (3.3 V) to set VREF = 0.75 V
- Set R2 = 10 kΩ and set R1 = kΩ

#### 8.2.2.2 Sense Resistor

For optimal performance, it is important for the sense resistor to be:

- Surface-mount
- Low inductance
- Rated for high enough power
- Placed closely to the motor driver

The power dissipated by the sense resistor equals I<sub>rms</sub><sup>2</sup> × R. For example, if the RMS motor current is 1.5 A and a 200-mΩ sense resistor is used, the resistor will dissipate 1.5 A<sup>2</sup> × 0.2 Ω = 0.3 W. The power quickly increases with greater current levels.

Resistors typically have a rated power within some ambient temperature range, along with a derated power curve for high ambient temperatures. When a PCB is shared with other components generating heat, margin should be added. It is always best to measure the actual sense resistor temperature in a final system, along with the power MOSFETs, as those are often the hottest components.

Because power resistors are larger and more expensive than standard resistors, it is common practice to use multiple standard resistors in parallel, between the sense node and ground. This distributes the current and heat dissipation.

### 8.2.3 Application Curves

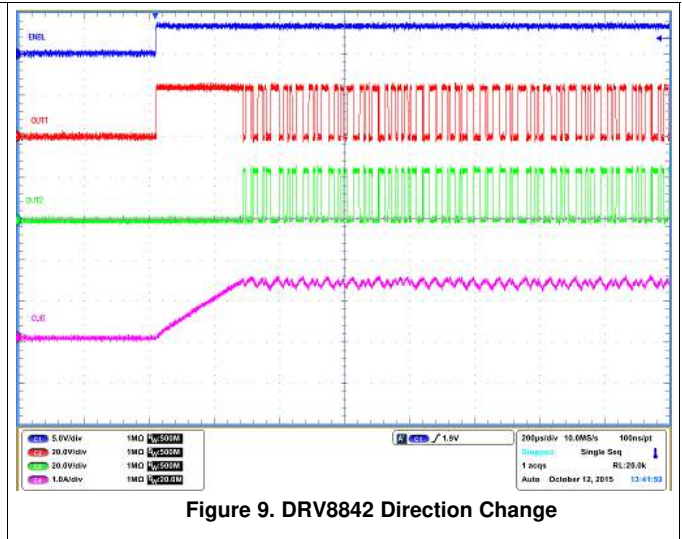
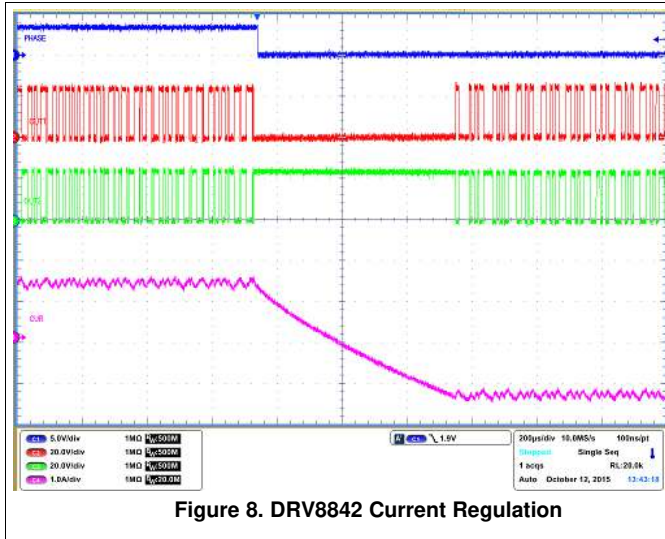

## 9 Power Supply Recommendations

The DRV8842 device is designed to operate from an input voltage supply (VM) range from 8.2 V to 45 V. The device has an absolute maximum rating of 47 V. A 0.1- $\mu$ F ceramic capacitor rated for VM must be placed at each VM pin as close to the DRV8842 as possible. In addition, a bulk capacitor must be included on VM.

### 9.1 Bulk Capacitance Sizing

Having appropriate local bulk capacitance is an important factor in motor drive system design. It is generally beneficial to have more bulk capacitance, while the disadvantages are increased cost and physical size.

The amount of local capacitance needed depends on a variety of factors, including:

- The highest current required by the motor system.
- The power supply's capacitance and ability to source current.
- The amount of parasitic inductance between the power supply and motor system.
- The acceptable voltage ripple.
- The type of motor used (Brushed DC, Brushless DC, Stepper).
- The motor braking method.

The inductance between the power supply and motor drive system will limit the rate current can change from the power supply. If the local bulk capacitance is too small, the system will respond to excessive current demands or dumps from the motor with a change in voltage. When adequate bulk capacitance is used, the motor voltage remains stable and high current can be quickly supplied.

The data sheet generally provides a recommended value, but system-level testing is required to determine the appropriate sized bulk capacitor.

The voltage rating for bulk capacitors should be greater than the operating voltage, to provide margin for cases when the motor transfers energy to the supply.

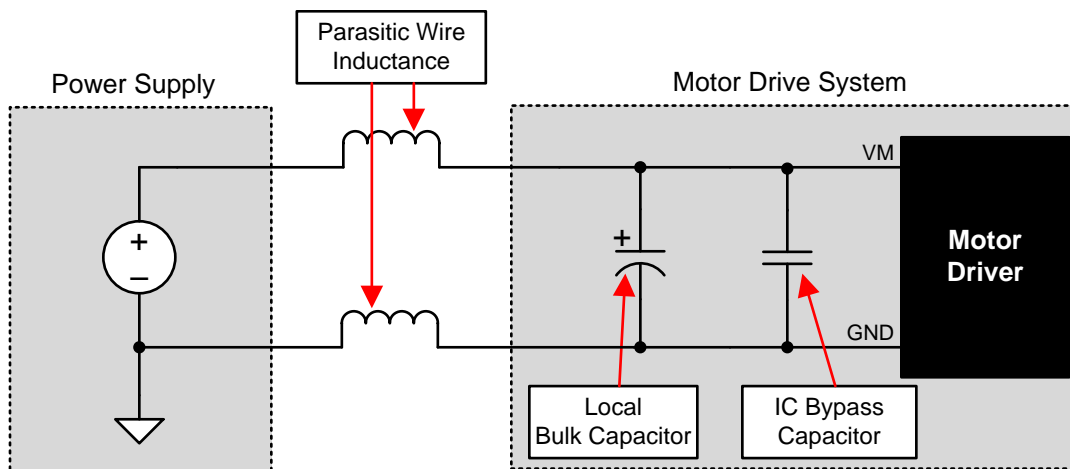

**Figure 10. Setup of Motor Drive System With External Power Supply**



## 10 Layout

### 10.1 Layout Guidelines

Each VM terminal must be bypassed to GND using a low-ESR ceramic bypass capacitors with recommended values of 0.1  $\mu\text{F}$  rated for VM. These capacitors should be placed as close to the VM pins as possible with a thick trace or ground plane connection to the device GND pin.

The VM pin must be bypassed to ground using a bulk capacitor rated for VM. This component may be an electrolytic.

A low-ESR ceramic capacitor must be placed in between the CP1 and CP2 pins. TI recommends a value of 0.1  $\mu\text{F}$  rated for VM . Place this component as close to the pins as possible.

A low-ESR ceramic capacitor must be placed in between the VM and VCP pins. TI recommends a value of 0.47  $\mu\text{F}$  rated for 16 V. Place this component as close to the pins as possible. In addition, place a 1 M $\Omega$  between VM and VCP.

Bypass V3P3OUT to ground with a ceramic capacitor rated 6.3 V. Place this bypassing capacitor as close to the pin as possible.

The current sense resistor should be placed as close as possible to the device pins to minimize trace inductance between the pin and resistor.

### 10.2 Layout Example

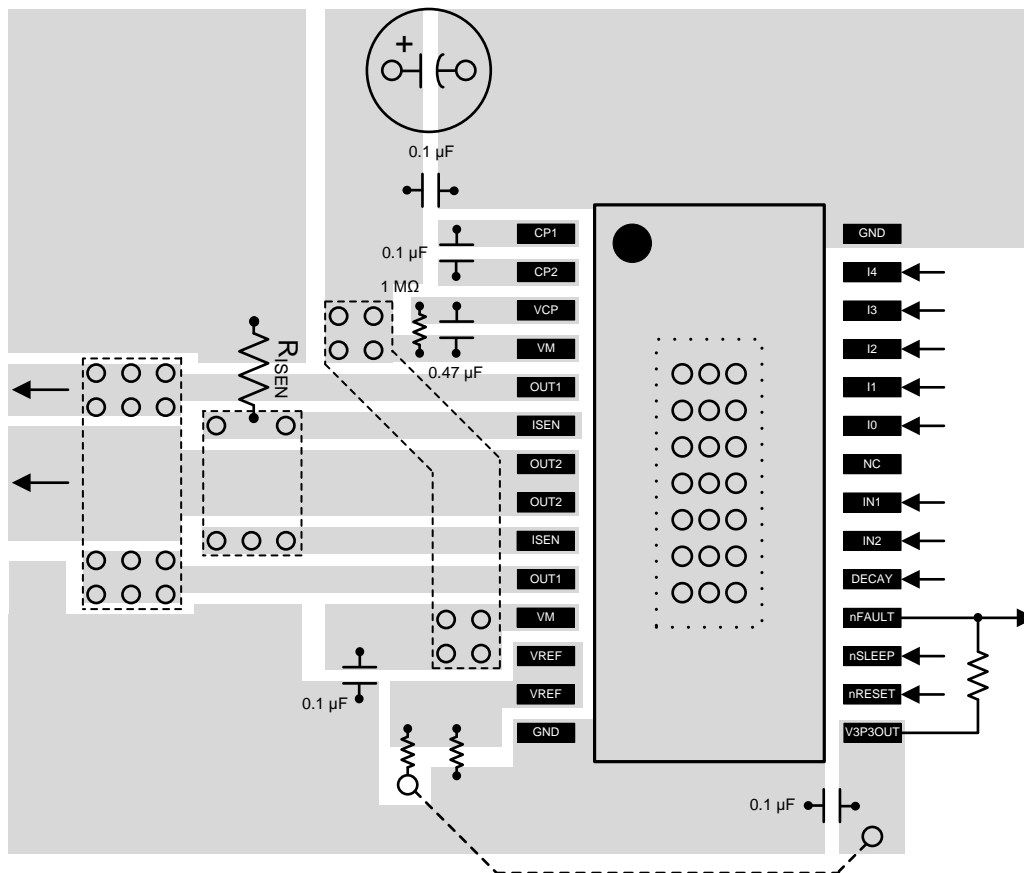

Figure 11. Example Layout

### 10.3 Thermal Considerations

The DRV8842 has thermal shutdown (TSD) as described above. If the die temperature exceeds approximately 150°C, the device will be disabled until the temperature drops to a safe level.

Any tendency of the device to enter TSD is an indication of either excessive power dissipation, insufficient heatsinking, or too high an ambient temperature.

#### 10.3.1 Power Dissipation

Average power dissipation in the DRV8842 when running a DC motor can be roughly estimated by: [Equation 3](#).

$$P = 2 \times R_{DS(ON)} \times (I_{OUT})^2 \quad (3)$$

where P is the power dissipation of one H-bridge,  $R_{DS(ON)}$  is the resistance of each FET, and  $I_{OUT}$  is the RMS output current being applied to each winding.  $I_{OUT}$  is equal to the average current drawn by the DC motor. Note that at start-up and fault conditions this current is much higher than normal running current; these peak currents and their duration also need to be taken into consideration. The factor of 2 comes from the fact that at any instant two FETs are conducting winding current (one high-side and one low-side).

The maximum amount of power that can be dissipated in the device is dependent on ambient temperature and heatsinking.

Note that  $R_{DS(ON)}$  increases with temperature, so as the device heats, the power dissipation increases. This must be taken into consideration when sizing the heatsink.

#### 10.3.2 Heatsinking

The PowerPAD™ package uses an exposed pad to remove heat from the device. For proper operation, this pad must be thermally connected to copper on the PCB to dissipate heat. On a multi-layer PCB with a ground plane, this can be accomplished by adding a number of vias to connect the thermal pad to the ground plane. On PCBs without internal planes, copper area can be added on either side of the PCB to dissipate heat. If the copper area is on the opposite side of the PCB from the device, thermal vias are used to transfer the heat between top and bottom layers.

For details about how to design the PCB, see the TI application report, *PowerPAD™ Thermally Enhanced Package (SLMA002)*, and the TI application brief, *PowerPAD™ Made Easy (SLMA004)*, available at [www.ti.com](http://www.ti.com).

In general, the more copper area that can be provided, the more power can be dissipated.

## 11 Device and Documentation Support

### 11.1 Documentation Support

#### 11.1.1 Related Documentation

For related documentation see the following:

- *Calculating Motor Driver Power Dissipation*, [SLVA504](#)
- *CPG005\_DRV88xx Evaluation Modules*, [SLVU410](#)
- *PowerPAD™ Thermally Enhanced Package*, [SLMA002](#)
- *PowerPAD™ Made Easy*, [SLMA004](#)
- *Solenoid Driving With DRV8841/42*, [SLVA460](#)
- *Various Reference Voltage Driving Techniques for Motor Drive Current Regulation*, [SLOA170](#)
- *Understanding Motor Driver Current Ratings*, [SLVA505](#)

### 11.2 Community Resources

The following links connect to TI community resources. Linked contents are provided "AS IS" by the respective contributors. They do not constitute TI specifications and do not necessarily reflect TI's views; see TI's [Terms of Use](#).

**TI E2E™ Online Community** *TI's Engineer-to-Engineer (E2E) Community*. Created to foster collaboration among engineers. At [e2e.ti.com](http://e2e.ti.com), you can ask questions, share knowledge, explore ideas and help solve problems with fellow engineers.

**Design Support** *TI's Design Support* Quickly find helpful E2E forums along with design support tools and contact information for technical support.

### 11.3 Trademarks

PowerPAD, E2E are trademarks of Texas Instruments.  
All other trademarks are the property of their respective owners.

### 11.4 Electrostatic Discharge Caution



These devices have limited built-in ESD protection. The leads should be shorted together or the device placed in conductive foam during storage or handling to prevent electrostatic damage to the MOS gates.

### 11.5 Glossary

[SLYZ022](#) — *TI Glossary*.

This glossary lists and explains terms, acronyms, and definitions.

## 12 Mechanical, Packaging, and Orderable Information

The following pages include mechanical, packaging, and orderable information. This information is the most current data available for the designated devices. This data is subject to change without notice and revision of this document. For browser-based versions of this data sheet, refer to the left-hand navigation.

**PACKAGING INFORMATION**

Orderable Device	Status (1)	Package Type	Package Drawing	Pins	Package Qty	Eco Plan (2)	Lead finish/ Ball material (6)	MSL Peak Temp (3)	Op Temp (°C)	Device Marking (4/5)	Samples
DRV8842PWP	ACTIVE	HTSSOP	PWP	28	50	RoHS & Green	NIPDAU	Level-3-260C-168 HR	-40 to 85	DRV8842	<a href="#">Samples</a>
DRV8842PWPR	ACTIVE	HTSSOP	PWP	28	2000	RoHS & Green	NIPDAU	Level-3-260C-168 HR	-40 to 85	DRV8842	<a href="#">Samples</a>

(1) The marketing status values are defined as follows:

**ACTIVE:** Product device recommended for new designs.

**LIFEBUY:** TI has announced that the device will be discontinued, and a lifetime-buy period is in effect.

**NRND:** Not recommended for new designs. Device is in production to support existing customers, but TI does not recommend using this part in a new design.

**PREVIEW:** Device has been announced but is not in production. Samples may or may not be available.

**OBSOLETE:** TI has discontinued the production of the device.

(2) **RoHS:** TI defines "RoHS" to mean semiconductor products that are compliant with the current EU RoHS requirements for all 10 RoHS substances, including the requirement that RoHS substance do not exceed 0.1% by weight in homogeneous materials. Where designed to be soldered at high temperatures, "RoHS" products are suitable for use in specified lead-free processes. TI may reference these types of products as "Pb-Free".

**RoHS Exempt:** TI defines "RoHS Exempt" to mean products that contain lead but are compliant with EU RoHS pursuant to a specific EU RoHS exemption.

**Green:** TI defines "Green" to mean the content of Chlorine (Cl) and Bromine (Br) based flame retardants meet JS709B low halogen requirements of <=1000ppm threshold. Antimony trioxide based flame retardants must also meet the <=1000ppm threshold requirement.

(3) MSL, Peak Temp. - The Moisture Sensitivity Level rating according to the JEDEC industry standard classifications, and peak solder temperature.

(4) There may be additional marking, which relates to the logo, the lot trace code information, or the environmental category on the device.

(5) Multiple Device Markings will be inside parentheses. Only one Device Marking contained in parentheses and separated by a "~" will appear on a device. If a line is indented then it is a continuation of the previous line and the two combined represent the entire Device Marking for that device.

(6) Lead finish/Ball material - Orderable Devices may have multiple material finish options. Finish options are separated by a vertical ruled line. Lead finish/Ball material values may wrap to two lines if the finish value exceeds the maximum column width.

**Important Information and Disclaimer:**The information provided on this page represents TI's knowledge and belief as of the date that it is provided. TI bases its knowledge and belief on information provided by third parties, and makes no representation or warranty as to the accuracy of such information. Efforts are underway to better integrate information from third parties. TI has taken and continues to take reasonable steps to provide representative and accurate information but may not have conducted destructive testing or chemical analysis on incoming materials and chemicals. TI and TI suppliers consider certain information to be proprietary, and thus CAS numbers and other limited information may not be available for release.

In no event shall TI's liability arising out of such information exceed the total purchase price of the TI part(s) at issue in this document sold by TI to Customer on an annual basis.

**OTHER QUALIFIED VERSIONS OF DRV8842 :**

- Enhanced Product: [DRV8842-EP](#)

## NOTE: Qualified Version Definitions:

- Enhanced Product - Supports Defense, Aerospace and Medical Applications

**TAPE AND REEL INFORMATION**

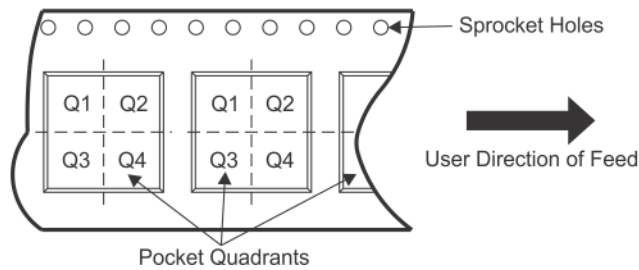
**QUADRANT ASSIGNMENTS FOR PIN 1 ORIENTATION IN TAPE**

\*All dimensions are nominal

Device	Package Type	Package Drawing	Pins	SPQ	Reel Diameter (mm)	Reel Width W1 (mm)	A0 (mm)	B0 (mm)	K0 (mm)	P1 (mm)	W (mm)	Pin1 Quadrant
DRV8842PWPR	HTSSOP	PWP	28	2000	330.0	16.4	6.9	10.2	1.8	12.0	16.0	Q1

**TAPE AND REEL BOX DIMENSIONS**

\*All dimensions are nominal

Device	Package Type	Package Drawing	Pins	SPQ	Length (mm)	Width (mm)	Height (mm)
DRV8842PWPR	HTSSOP	PWP	28	2000	350.0	350.0	43.0

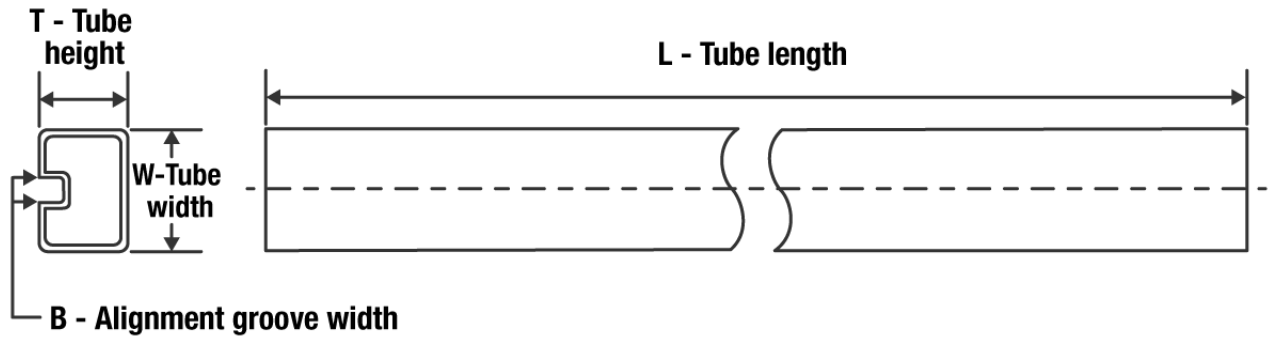
**TUBE**

\*All dimensions are nominal

Device	Package Name	Package Type	Pins	SPQ	L (mm)	W (mm)	T (μm)	B (mm)
DRV8842PWP	PWP	HTSSOP	28	50	530	10.2	3600	3.5



## GENERIC PACKAGE VIEW

**PWP 28**

**PowerPAD™ TSSOP - 1.2 mm max height**

4.4 x 9.7, 0.65 mm pitch

SMALL OUTLINE PACKAGE

This image is a representation of the package family, actual package may vary.  
Refer to the product data sheet for package details.

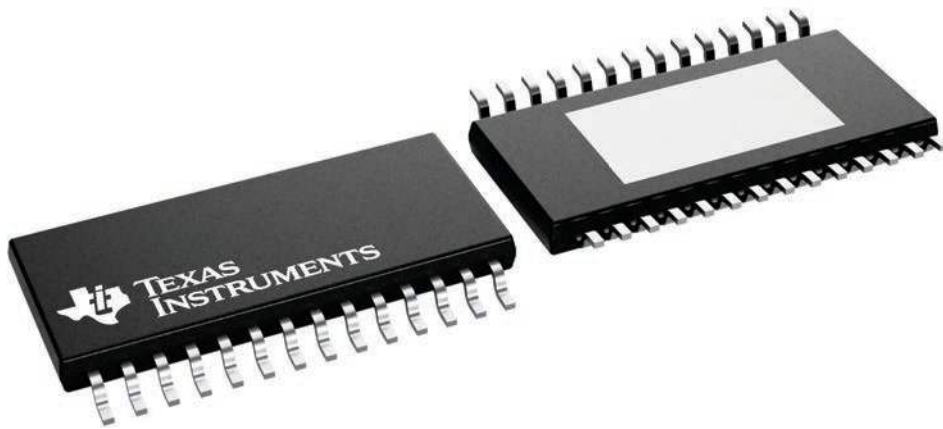

4224765/B

# PWP0028C

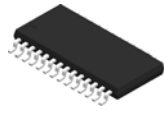

# PACKAGE OUTLINE

## PowerPAD™ TSSOP - 1.2 mm max height

SMALL OUTLINE PACKAGE

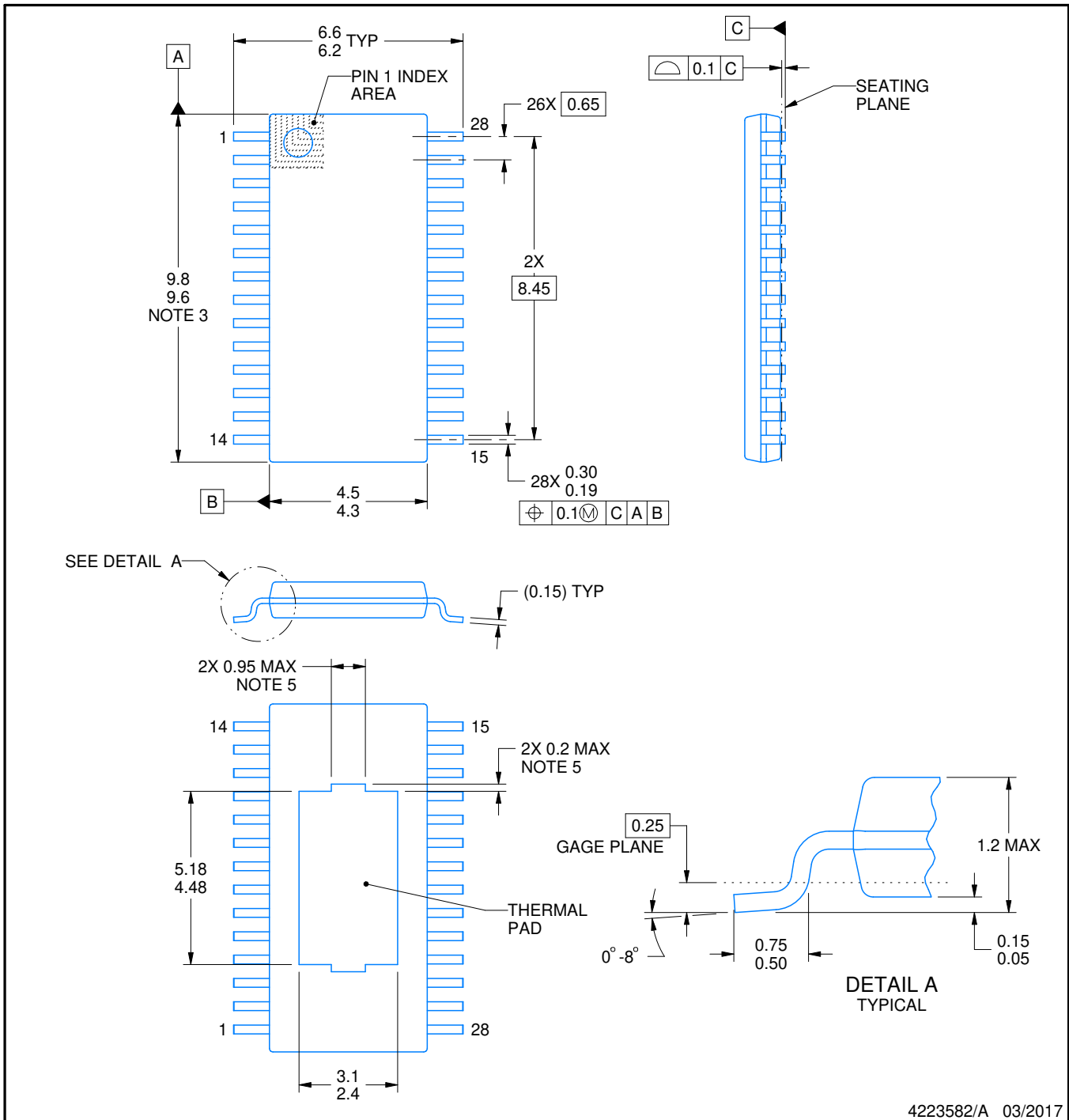

4223582/A 03/2017

### NOTES:

PowerPAD is a trademark of Texas Instruments.

1. All linear dimensions are in millimeters. Any dimensions in parenthesis are for reference only. Dimensioning and tolerancing per ASME Y14.5M.
2. This drawing is subject to change without notice.
3. This dimension does not include mold flash, protrusions, or gate burrs. Mold flash, protrusions, or gate burrs shall not exceed 0.15 mm per side.
4. Reference JEDEC registration MO-153.
5. Features may differ or may not be present.



# EXAMPLE STENCIL DESIGN

PWP0028C

PowerPAD™ TSSOP - 1.2 mm max height

SMALL OUTLINE PACKAGE

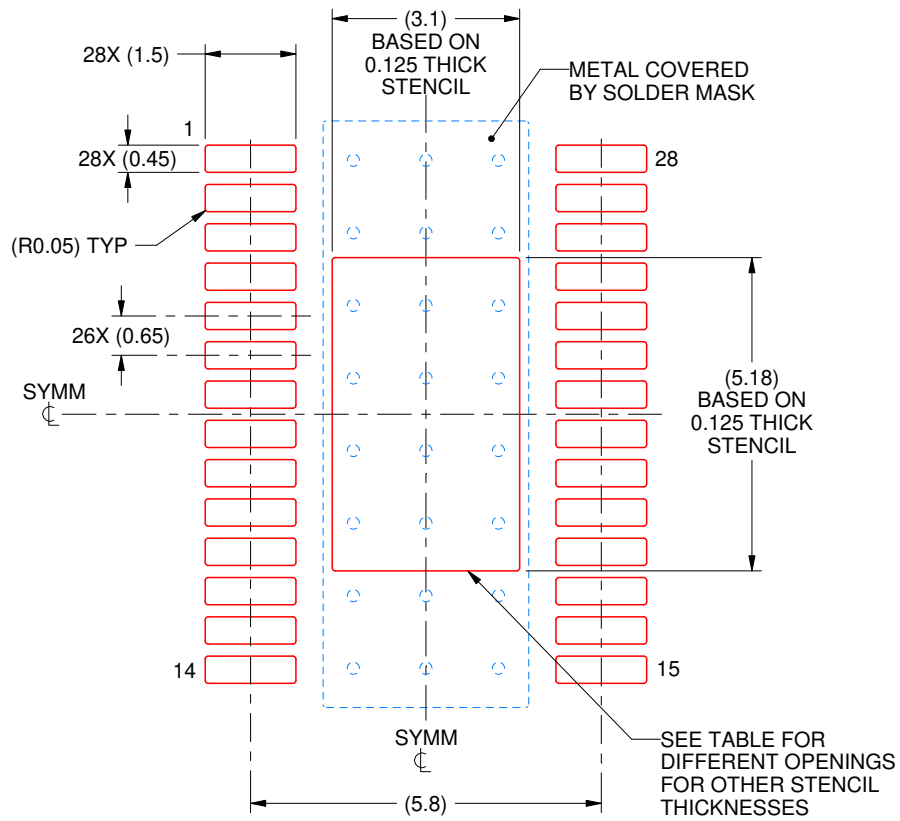

**SOLDER PASTE EXAMPLE**  
 BASED ON 0.125 mm THICK STENCIL  
 SCALE: 8X

STENCIL THICKNESS	SOLDER STENCIL OPENING
0.1	3.47 X 5.79
0.125	3.10 X 5.18 (SHOWN)
0.15	2.83 X 4.73
0.175	2.62 X 4.38

4223582/A 03/2017

NOTES: (continued)

11. Laser cutting apertures with trapezoidal walls and rounded corners may offer better paste release. IPC-7525 may have alternate design recommendations.
12. Board assembly site may have different recommendations for stencil design.

## IMPORTANT NOTICE AND DISCLAIMER

TI PROVIDES TECHNICAL AND RELIABILITY DATA (INCLUDING DATA SHEETS), DESIGN RESOURCES (INCLUDING REFERENCE DESIGNS), APPLICATION OR OTHER DESIGN ADVICE, WEB TOOLS, SAFETY INFORMATION, AND OTHER RESOURCES "AS IS" AND WITH ALL FAULTS, AND DISCLAIMS ALL WARRANTIES, EXPRESS AND IMPLIED, INCLUDING WITHOUT LIMITATION ANY IMPLIED WARRANTIES OF MERCHANTABILITY, FITNESS FOR A PARTICULAR PURPOSE OR NON-INFRINGEMENT OF THIRD PARTY INTELLECTUAL PROPERTY RIGHTS.

These resources are intended for skilled developers designing with TI products. You are solely responsible for (1) selecting the appropriate TI products for your application, (2) designing, validating and testing your application, and (3) ensuring your application meets applicable standards, and any other safety, security, regulatory or other requirements.

These resources are subject to change without notice. TI grants you permission to use these resources only for development of an application that uses the TI products described in the resource. Other reproduction and display of these resources is prohibited. No license is granted to any other TI intellectual property right or to any third party intellectual property right. TI disclaims responsibility for, and you will fully indemnify TI and its representatives against, any claims, damages, costs, losses, and liabilities arising out of your use of these resources.

TI's products are provided subject to [TI's Terms of Sale](#) or other applicable terms available either on [ti.com](http://ti.com) or provided in conjunction with such TI products. TI's provision of these resources does not expand or otherwise alter TI's applicable warranties or warranty disclaimers for TI products.

TI objects to and rejects any additional or different terms you may have proposed.

Mailing Address: Texas Instruments, Post Office Box 655303, Dallas, Texas 75265  
Copyright © 2022, Texas Instruments Incorporated