

ISL3295E, ISL3298E

±16.5kV ESD Protected, +125°C, 3.0V to 5.5V, SOT-23/TDFN Packaged, Low Power, RS-485/RS-422 Transmitters

FN6544
Rev.4.00
Oct 9, 2019

The [ISL3295E](#) and [ISL3298E](#) are ±16.5kV HBM ESD Protected (7kV IEC61000 contact), 3.0V to 5.5V powered, single transmitters for balanced communication using the RS-485 and RS-422 standards. These drivers have very low output leakage current (±40µA), so they present less than a “1/8 unit load” to the RS-485 bus. This allows more than 256 transmitters on the network without violating the RS-485 specification’s 32 unit load maximum, and without using repeaters.

Hot Plug circuitry ensures that the Tx outputs remain in a high impedance state while the power supply stabilizes.

Drivers on the ISL3295E and ISL3298E are not limited, so they can achieve the 20Mbps data rate. They are offered in industrial and extended industrial (-40°C to +125°C) temperature ranges.

A 26% smaller footprint is available with the ISL3298E TDFN package. This device also features a logic supply pin (V_L) that sets the switching points of the DE and DI inputs to be compatible with a lower supply voltage in mixed voltage systems.

For companion single RS-485 receivers in micro packages, please see the [ISL3280E](#), [ISL3281E](#), [ISL3282E](#), [ISL3283E](#), [ISL3284E](#) datasheet.

Related Literature

For a full list of related documents, visit our website

- [ISL3295E](#) and [ISL3298E](#) device pages

Features

- High ESD protection on RS-485 outputs ±16.5kV HBM
 - IEC61000-4-2 contact test method ±7kV
 - Class 3 ESD level on all other pins. >8kV HBM
- Specified for +125°C operation (V_{CC} ≤ 3.6V only)
- Logic supply pin (V_L) eases operation in mixed supply systems (ISL3298E only)
- Hot plug - Tx outputs remain three-state during power-up
- Low Tx leakage allows >256 devices on the bus
- High data rates. up to 20Mbps
- Low quiescent supply current. 150µA (max)
 - Very low shutdown supply current 1µA (max)
- -7V to +12V common-mode output voltage range (V_{CC} ≤ 3.6V only)
- Current limiting and thermal shutdown for driver overload protection (V_{CC} ≤ 3.6V only)
- Tri-statable Tx outputs
- 5V tolerant logic inputs when V_{CC} ≤ 5V
- Pb-free (RoHS compliant)

Applications

- Clock distribution
- High node count systems
- Space constrained systems
- Security camera networks
- Building environmental control/lighting systems
- Industrial/process control networks

TABLE 1. SUMMARY OF FEATURES

PART NUMBER	FUNCTION	DATA RATE (Mbps)	SLEW RATE LIMITED?	HOT PLUG?	V _L PIN?	TX ENABLE? (Note 11)	MAXIMUM QUIESCENT I _{CC} (µA)	LOW POWER SHUTDOWN?	PIN COUNT
ISL3295E	1 Tx	20	NO	YES	NO	YES	150	YES	6 Ld SOT
ISL3298E	1 Tx	20	NO	YES	YES	YES	150	YES	8 Ld TDFN

Pin Configurations

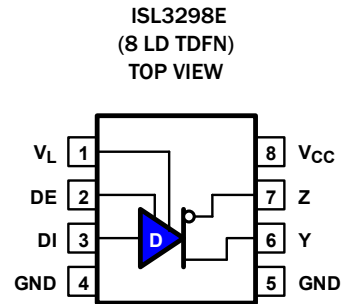
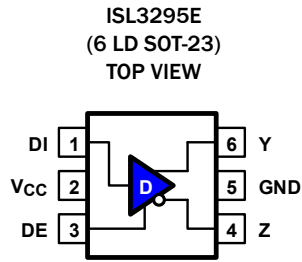

NOTE: BOTH GND PINS MUST BE CONNECTED

Truth Tables

TRANSMITTING			
INPUTS		OUTPUTS	
DE (Note 11)	DI	Z	Y
1	1	0	1
1	0	1	0
0	X	High-Z *	High-Z *

NOTE: *Shutdown Mode

Pin Descriptions

PIN NAME	FUNCTION
DE	Driver output enable. The driver outputs, Y and Z, are enabled by bringing DE high, and are high impedance when DE is low. If the driver enable function isn't needed, connect DE to V _{CC} (or V _L) through a 1kΩ to 3kΩ resistor.
DI	Driver input. A low on DI forces output Y low and output Z high. Similarly, a high on DI forces output Y high and output Z low.
GND	Ground connection. This is also the potential of the TDFN thermal pad.
Y	±15kV HBM, ±7kV IEC61000 (contact method) ESD Protected RS-485/422 level, noninverting transmitter output.
Z	±15kV HBM, ±7kV IEC61000 (contact method) ESD Protected RS-485/422 level, inverting transmitter output.
V _{CC}	System power supply input (3.0V to 5.5V). On devices with a V _L pin powered from a separate supply, power-up V _{CC} first.
V _L	Logic-level supply which sets the V _{IL} /V _{IH} levels for the DI and DE pins (ISL3298E only). If V _L and V _{CC} are different supplies, power-up this supply after V _{CC} , and keep V _L ≤ V _{CC} .

Ordering Information

PART NUMBER (Notes 1, 3)	PART MARKING (Note 4)	TEMP. RANGE (°C)	TAPE AND REEL (UNITS) (Note 2)	PACKAGE (RoHS Compliant)	PKG. DWG. #
ISL3295EFHZ-T	295F	-40 to +125	3k	6 Ld SOT-23	P6.064
ISL3295EFHZ-T7A	295F	-40 to +125	250	6 Ld SOT-23	P6.064
ISL3295EIHZ-T	295I	-40 to +85	3k	6 Ld SOT-23	P6.064
ISL3295EIHZ-T7A	295I	-40 to +85	250	6 Ld SOT-23	P6.064
ISL3298EFRTZ-T	98F	-40 to +125	6k	8 Ld TDFN	L8.2x3A

NOTES:

1. These Pb-free plastic packaged products employ special Pb-free material sets, molding compounds/die attach materials, and 100% matte tin plate plus anneal (e3 termination finish, which is RoHS compliant and compatible with both SnPb and Pb-free soldering operations). Pb-free products are MSL classified at Pb-free peak reflow temperatures that meet or exceed the Pb-free requirements of IPC/JEDEC J-STD-020.
2. See [TB347](#) for details about reel specifications.
3. For Moisture Sensitivity Level (MSL), see the [ISL3295E](#) and [ISL3298E](#) device pages. For more information about MSL, see [TB363](#).
4. SOT-23 "PART MARKING" is branded on the bottom side.

Typical Operating Circuits

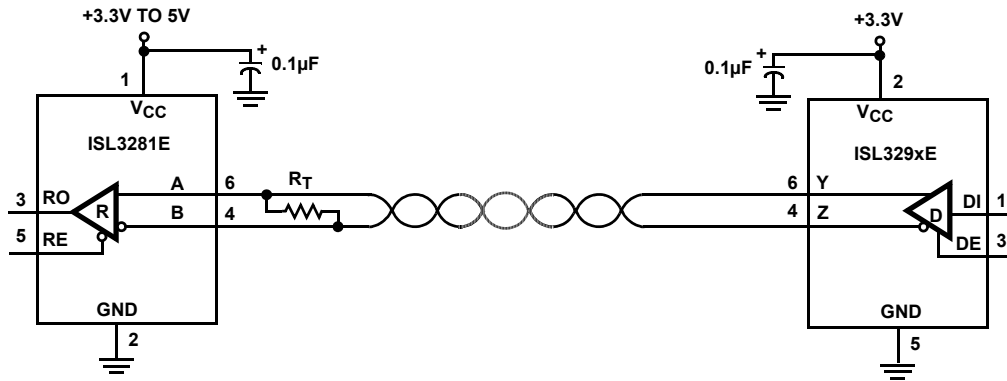

FIGURE 1. NETWORK WITH ENABLES

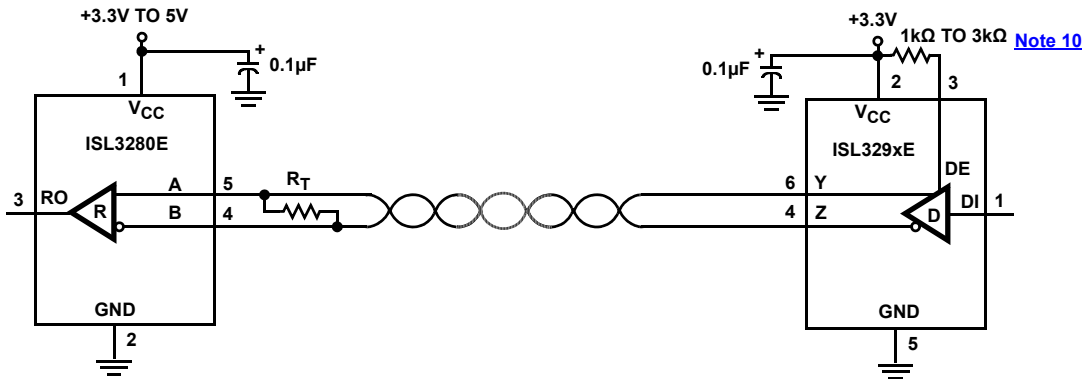

FIGURE 2. NETWORK WITHOUT ENABLE

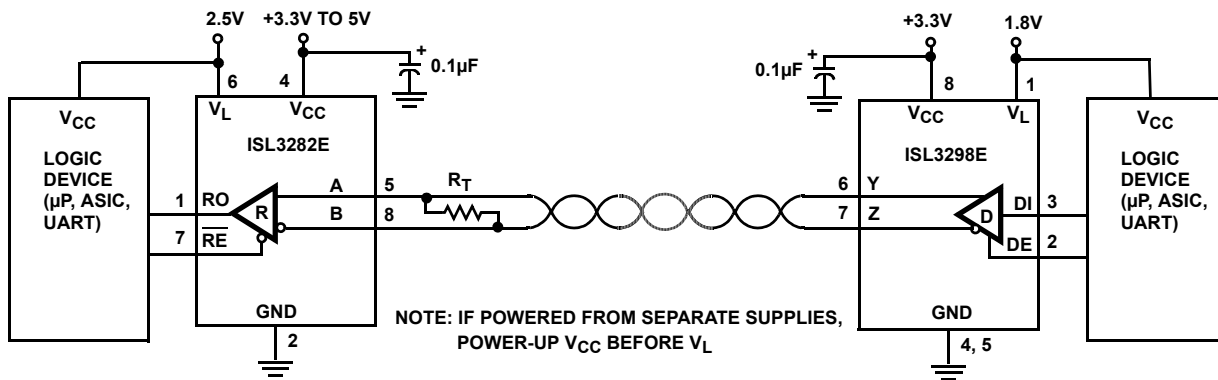

FIGURE 3. NETWORK WITH VL PIN FOR INTERFACING TO LOWER VOLTAGE LOGIC DEVICES

Absolute Maximum Ratings

V_{CC} to GND	-0.3V to 7V
V_L to GND (ISL3298E Only)	-0.3V to ($V_{CC} + 0.3V$)
Input Voltages	
DI, DE	-0.3V to 7V
Output Voltages	
Y, Z ($V_{CC} \leq 3.6V$)	-8V to +13V
Y, Z ($V_{CC} > 3.6V$)	-0.5V to $V_{CC} + 0.5V$
Short-circuit Duration	
Y, Z ($V_{CC} \leq 3.6V$)	Continuous
Y, Z ($V_{CC} > 3.6V$, Note 13)	1s at <300mA
ESD Rating	See Electrical Specifications on page 6

Thermal Information

Thermal Resistance (Typical)	θ_{JA} ($^{\circ}C/W$)	θ_{JC} ($^{\circ}C/W$)
6 Ld SOT-23 Package (Note 5)	177	N/A
8 Ld TDFN Package (Notes 6, 7)	65	8
Maximum Junction Temperature (Plastic Package)	+150 $^{\circ}C$	
Maximum Storage Temperature Range	-65 $^{\circ}C$ to +150 $^{\circ}C$	
Pb-free Reflow Profile	see TB493	

Operating Conditions

Temperature Range	
F Suffix ($V_{CC} \leq 3.6V$ only)	-40 $^{\circ}C$ to +125 $^{\circ}C$
I Suffix	-40 $^{\circ}C$ to +85 $^{\circ}C$

CAUTION: Do not operate at or near the maximum ratings listed for extended periods of time. Exposure to such conditions can adversely impact product reliability and result in failures not covered by warranty.

NOTES:

- θ_{JA} is measured with the component mounted on a high-effective thermal conductivity test board in free air. See [TB379](#) for details.
- θ_{JA} is measured in free air with the component mounted on a high effective thermal conductivity test board with "direct attach" features. See [TB379](#).
- For θ_{JC} , the "case temp" location is the center of the exposed metal pad on the package underside.

Electrical Specifications Test Conditions: $V_{CC} = 3.0V$ to $5.5V$, $V_L = V_{CC}$ (ISL3298E only), typicals are at $T_A = +25^{\circ}C$, unless otherwise specified. ([Note 8](#))

PARAMETER	SYMBOL	TEST CONDITIONS	TEMP ($^{\circ}C$)	MIN (Note 12)	TYP (Note 14)	MAX (Note 12)	UNIT	
DC CHARACTERISTICS								
Driver Differential V_{OUT}	V_{OD}	$R_L = 100\Omega$ (RS-422) (Figure 4A)	$V_{CC} \geq 3.15V$	Full	2	2.3	-	V
			$V_{CC} \geq 4.5V$	Full	3	3.8	-	V
	$R_L = 54\Omega$ (RS-485) (Figure 4A)	$V_{CC} \geq 3.0V$	Full	1.5	2	V_{CC}	V	
		$V_{CC} \geq 4.5V$	Full	2.5	3.4	V_{CC}	V	
	No load	Full	-	-	V_{CC}			
		$R_L = 60\Omega$, $-7V \leq V_{CM} \leq 12V$ (Figure 4B)	Full	1.5	2, 3.4	-	V	
Change in Magnitude of Driver Differential V_{OUT} for Complementary Output States	ΔV_{OD}	$R_L = 54\Omega$ or 100Ω (Figure 4A)	Full	-	0.01	0.2	V	
Driver Common-mode V_{OUT}	V_{OC}	$R_L = 54\Omega$ or 100Ω (Figure 4A)	$V_{CC} \leq 3.6V$	Full	-	2	3	V
			$V_{CC} \leq 5.5V$	Full	-	-	3.2	V
Change in Magnitude of Driver Common-mode V_{OUT} for Complementary Output States	ΔV_{OC}	$R_L = 54\Omega$ or 100Ω (Figure 4A)	Full	-	0.01	0.2	V	
Input High Voltage (DI, DE)	V_{IH1}	$V_L = V_{CC}$ if ISL3298E	$V_{CC} \leq 3.6V$	Full	2.2	-	-	V
	$V_{CC} \leq 5.5V$		Full	3	-	-	V	
	V_{IH2}							
	V_{IH3}	$2.7V \leq V_L < 3.0V$ (ISL3298E only)	Full	2	-	-	V	
	V_{IH4}	$2.3V \leq V_L < 2.7V$ (ISL3298E only)	Full	1.65	-	-	V	
	V_{IH5}	$1.6V \leq V_L < 2.3V$ (ISL3298E only)	Full	$0.7 \cdot V_L$	-	-	V	
V_{IH6}	$1.35V \leq V_L < 1.6V$ (ISL3298E only)	25	-	$0.5 \cdot V_L$	-	V		

Electrical Specifications Test Conditions: $V_{CC} = 3.0V$ to $5.5V$, $V_L = V_{CC}$ (ISL3298E only), typicals are at $T_A = +25^\circ C$, unless otherwise specified. (Note 8) (Continued)

PARAMETER	SYMBOL	TEST CONDITIONS	TEMP (°C)	MIN (Note 12)	TYP (Note 14)	MAX (Note 12)	UNIT	
Input Low Voltage (DI, DE)	V_{IL1}	$V_L = V_{CC}$ if ISL3298E	Full	-	-	0.8	V	
	V_{IL2}	$V_L \geq 2.7V$ (ISL3298E only)	Full	-	-	0.8	V	
	V_{IL3}	$2.3V \leq V_L < 2.7V$ (ISL3298E only)	Full	-	-	0.65	V	
	V_{IL4}	$1.6V \leq V_L < 2.3V$ (ISL3298E only)	Full	-	-	$0.22 \cdot V_L$	V	
	V_{IL5}	$1.35V \leq V_L < 1.6V$ (ISL3298E only)	25	-	$0.3 \cdot V_L$	-	V	
Logic Input Current	I_{IN}	DI = DE = 0V or V_{CC} (Note 11)	Full	-2	-	2	μA	
Output Leakage Current (Y, Z, Note 11)	I_{OZ}	DE = 0V, $V_{CC} = 0V, 3.6V, \text{ or } 5.5V$	$V_{IN} = 12V$	Full	-	0.1	40	μA
			$V_{IN} = -7V$	Full	-40	-10	-	μA
Driver Short-circuit Current, $V_O = \text{High or Low}$ (Note 9)	I_{OSD1}	DE = V_{CC} , $-7V \leq V_O \leq 12V$, $V_{CC} \leq 3.6V$		Full	-	-	± 250	mA
		DE = V_{CC} , $0V \leq V_O \leq V_{CC}$, $V_{CC} > 3.6V$ (Note 13)		Full	-	-	± 450	mA
Thermal Shutdown Threshold	T_{SD}		Full	-	160	-	$^\circ C$	
SUPPLY CURRENT								
No-load Supply Current	I_{CC}	DI = 0V or V_{CC}	DE = V_{CC}	Full	-	120	150	μA
Shutdown Supply Current	I_{SHDN}	DE = 0V, DI = 0V or V_{CC}		Full	-	0.01	1	μA
ESD PERFORMANCE								
RS-485 Pins (Y, Z)		Human Body Model, from bus pins to GND		25	-	± 16.5	-	kV
		IEC61000 Contact, from bus pins to GND		25	-	± 7	-	kV
All Pins		HBM, per MIL-STD-883 Method 3015		25	-	± 8	-	kV
		Machine Model		25	-	± 400	-	V
DRIVER SWITCHING CHARACTERISTICS								
Maximum Data Rate	f_{MAX}	$V_{OD} = \pm 1.5V$, $C_D = 360pF$ (Figure 7)		Full	20	-	-	Mbps
Driver Single-ended Output Delay	t_{SD}	$R_{DIFF} = 54\Omega$, $C_D = 50pF$ (Figure 5)	$V_L = V_{CC}$	Full	15	29, 23	42	ns
			$V_L \geq 1.8V$	25	-	32	-	ns
			$V_L = 1.5V$	25	-	36	-	ns
			$V_L = 1.35V$	25	-	40	-	ns
Part-to-part Output Delay Skew	t_{SKPP}	$R_{DIFF} = 54\Omega$, $C_D = 50pF$ (Figure 5, Note 10)		Full	-	-	25	ns
Driver Single-ended Output Skew	t_{SSK}	$R_{DIFF} = 54\Omega$, $C_D = 50pF$ (Figure 5)	$V_L = V_{CC}$	Full	-	3	7	ns
			$V_L \geq 1.8V$	25	-	3	-	ns
			$V_L = 1.5V$	25	-	4	-	ns
			$V_L = 1.35V$	25	-	5	-	ns
Driver Differential Output Delay	t_{DD}	$R_{DIFF} = 54\Omega$, $C_D = 50pF$ (Figure 5)	$V_L = V_{CC}$	Full	-	29, 22	42	ns
			$V_L \geq 1.8V$	25	-	32	-	ns
			$V_L = 1.5V$	25	-	36	-	ns
			$V_L = 1.35V$	25	-	42	-	ns

Electrical Specifications Test Conditions: $V_{CC} = 3.0V$ to $5.5V$, $V_L = V_{CC}$ (ISL3298E only), typicals are at $T_A = +25^\circ C$, unless otherwise specified. (Note 8) (Continued)

PARAMETER	SYMBOL	TEST CONDITIONS	TEMP (°C)	MIN (Note 12)	TYP (Note 14)	MAX (Note 12)	UNIT	
Driver Differential Output Skew	t_{DSK}	$R_{DIFF} = 54\Omega$, $C_D = 50pF$ (Figure 5)	$V_L = V_{CC} \leq 3.6V$	Full	-	0.5	3	ns
			$V_L = V_{CC} = 5V$	25	-	2	-	ns
			$V_L \geq 1.8V$	25	-	0.5, 1	-	ns
			$V_L \geq 1.5V$	25	-	1, 2	-	ns
			$V_L = 1.35V$	25	-	2, 4	-	ns
Driver Differential Rise or Fall Time	t_R, t_F	$R_{DIFF} = 54\Omega$, $C_D = 50pF$ (Figure 5)	$V_L = V_{CC}$	Full	-	9	15	ns
			$V_L \geq 1.35V$	25	-	9	-	ns
Driver Enable to Output High	t_{ZH}	$R_L = 500\Omega, C_L = 50pF, SW = GND$ (Figure 6)	Full	-	100, 60	250	ns	
Driver Enable to Output Low	t_{ZL}	$R_L = 500\Omega, C_L = 50pF, SW = V_{CC}$ (Figure 6)	Full	-	60, 35	250	ns	
Driver Disable from Output High	t_{HZ}	$R_L = 500\Omega, C_L = 50pF, SW = GND$ (Figure 6)	Full	-	30, 22	60	ns	
Driver Disable from Output Low	t_{LZ}	$R_L = 500\Omega, C_L = 50pF, SW = V_{CC}$ (Figure 6)	Full	-	25, 20	60	ns	

NOTES:

- All currents into device pins are positive; all currents out of device pins are negative. All voltages are referenced to device ground unless otherwise specified.
- Applies to peak current. See "Typical Performance Curves" on page 11 for more information.
- t_{SKPP} is the magnitude of the difference in propagation delays of the specified terminals of two units tested with identical test conditions (such as V_{CC} , temperature).
- If the driver enable function is not needed, connect DE to V_{CC} (or V_L) through a $1k\Omega$ to $3k\Omega$ resistor.
- Parts are 100% tested at $+25^\circ C$. Over-temperature limits established by characterization and are not production tested.
- Due to the high short-circuit current at $V_{CC} > 3.6V$, the outputs must not be shorted outside the range of GND to V_{CC} or damage may occur. To prevent excessive power dissipation that may damage the output, the short-circuit current should be limited to $\leq 300mA$ during testing. It is best to use an external resistor for this purpose, because the current limiting on the V_O supply may respond too slowly to protect the output.
- Typicals are measured at $V_{CC} = 3.3V$ for parameters specified with $3V \leq V_{CC} \leq 3.6V$, and are measured at $V_{CC} = 5V$ for parameters specified with $4.5V \leq V_{CC} \leq 5.5V$. If V_{CC} isn't specified, then a single "TYP" entry applies to both $V_{CC} = 3.3V$ and $5V$, and two entries separated by a comma refer to $V_{CC} = 3.3V$ and $5V$, respectively.

Test Circuits and Waveforms

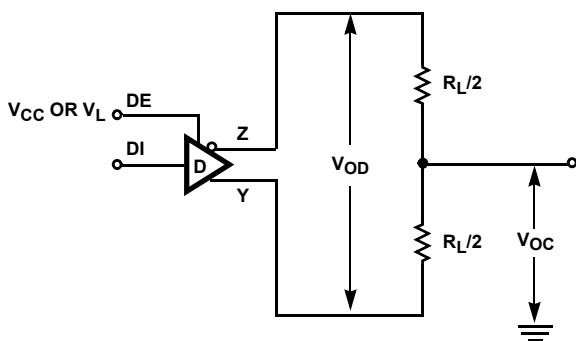

FIGURE 4A. V_{OD} AND V_{OC}

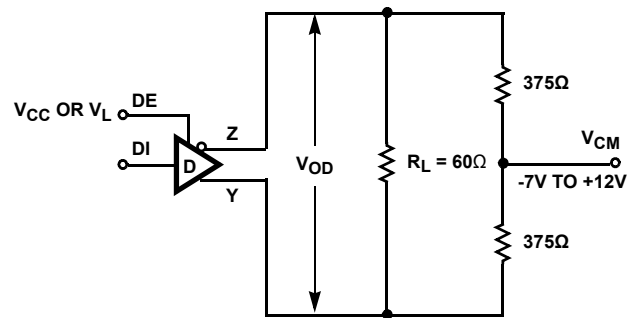

FIGURE 4B. V_{OD} WITH COMMON-MODE LOAD

FIGURE 4. DC DRIVER TEST CIRCUITS

Test Circuits and Waveforms (Continued)

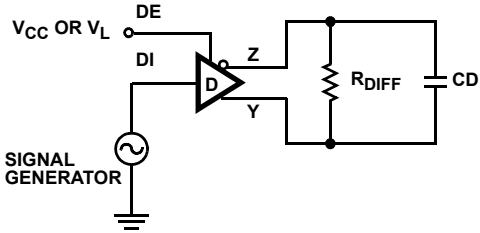

FIGURE 5A. TEST CIRCUIT

FIGURE 5. DRIVER PROPAGATION DELAY AND DIFFERENTIAL TRANSITION TIMES

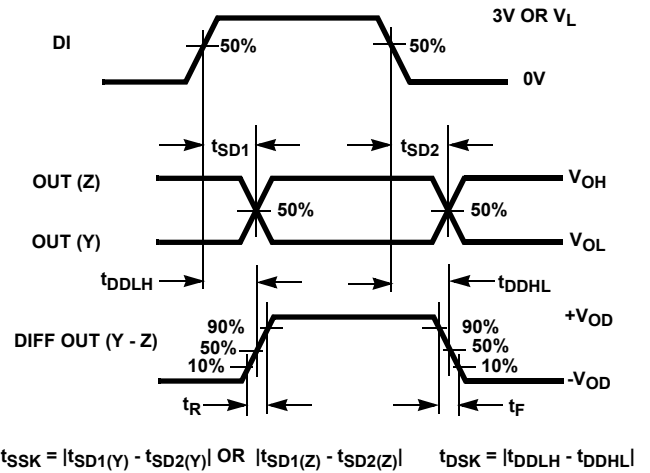
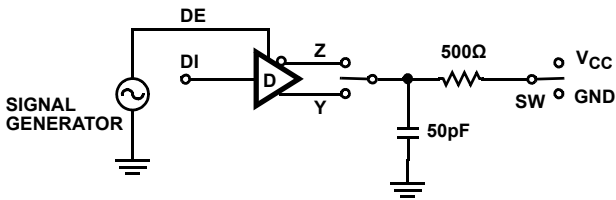

FIGURE 5B. MEASUREMENT POINTS



PARAMETER	OUTPUT	DI	SW
t_{HZ}	Y/Z	1/0	GND
t_{LZ}	Y/Z	0/1	V_{CC}
t_{ZH}	Y/Z	1/0	GND
t_{ZL}	Y/Z	0/1	V_{CC}

FIGURE 6A. TEST CIRCUIT

FIGURE 6. DRIVER ENABLE AND DISABLE TIMES

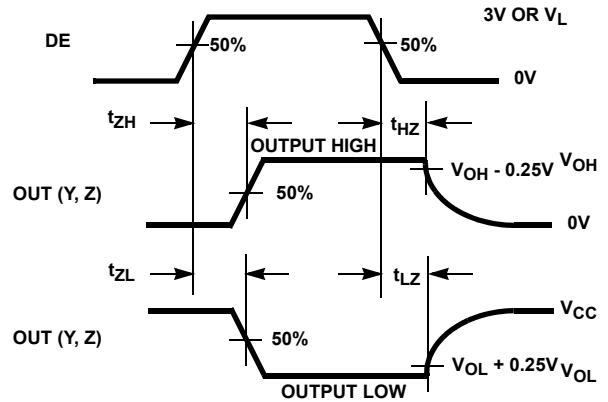

FIGURE 6B. MEASUREMENT POINTS

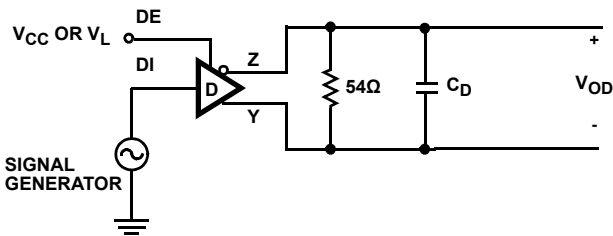

FIGURE 7A. TEST CIRCUIT

FIGURE 7. DRIVER DATA RATE

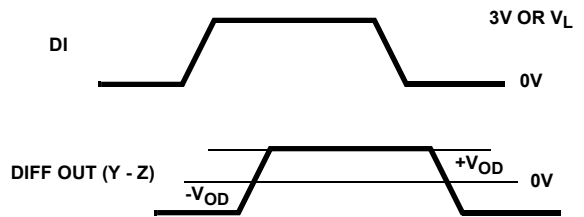

FIGURE 7B. MEASUREMENT POINTS

Application Information

RS-485 and RS-422 are differential (balanced) data transmission standards for use in long haul or noisy environments. RS-422 is a subset of RS-485, so RS-485 transmitters and receivers are also RS-422 compliant. RS-422 is a point-to-multipoint (multidrop) standard, which allows only one driver and up to 10 (assuming one unit load devices) receivers on each bus. RS-485 is a true multipoint standard, which allows up to 32 one unit load devices (any combination of drivers and receivers) on each bus. To allow for multipoint operation, the RS-485 specification requires that drivers must handle bus contention without sustaining any damage.

Another important advantage of RS-485 is the extended Common-Mode Range (CMR), which specifies that the driver outputs and receiver inputs withstand signals that range from +12V to -7V. RS-422 and RS-485 are intended for runs as long as 4000', so the wide CMR is necessary to handle ground potential differences, as well as voltages induced in the cable by external fields.

Driver Features

These RS-485/RS-422 drivers are differential output devices that delivers at least 1.5V across a 54Ω load (RS-485) and at least 2V across a 100Ω load (RS-422). The drivers feature low propagation delay skew to maximize bit width and to minimize EMI.

All drivers are tri-statable via the active high DE input. If the Tx enable function is not needed, tie DE to V_{CC} (or V_L) through a 1kΩ to 3kΩ resistor.

The outputs of the ISL3295E and ISL3298E drivers are not slew rate limited, so faster output transition times allow data rates of at least 20Mbps.

Wide Supply Range

The ISL3295E and ISL3298E are optimized for 3.3V operation, but can be operated with supply voltages as high as 5.5V. These devices meet the RS-422 and RS-485 specifications for supply voltages less than 4V, and are RS-422 and RS-485 compatible for supplies greater than 4V. Operation at +125°C requires $V_{CC} \leq 3.6V$, while 5V operation requires adding output current limiting resistors (as described in the [“Driver Overload Protection” on page 10](#)) if output short-circuits (for example, from bus contention) are a possibility.

5.5V Tolerant Logic Pins

Logic input pins (DI, DE) contain no ESD nor parasitic diodes to V_{CC} (nor to V_L), so they withstand input voltages exceeding 5.5V regardless of the V_{CC} and V_L voltages.

Logic Supply (V_L Pin, ISL3298E)

Note: If powered from separate supplies, power-up V_{CC} before powering up the V_L supply and keep $V_L \leq V_{CC}$.

The ISL3298E includes a V_L pin that powers the logic inputs (DI and DE). This pin interfaces with “logic” devices such as UARTs, ASICs, and μ controllers, and today most of these devices use power supplies significantly lower than 3.3V. Thus, the logic device’s low V_{OH} might not exceed the V_{IH} of a 3.3V or 5V

powered DI or DE input. Connecting the V_L pin to the power supply of the logic device (as shown in [Figure 8](#)) reduces the DI and DE input switching points to values compatible with the logic device’s output levels. Tailoring the logic pin input switching points and output levels to the supply voltage of the UART, ASIC, or μ controller eliminates the need for a level shifter/translator between the two ICs.

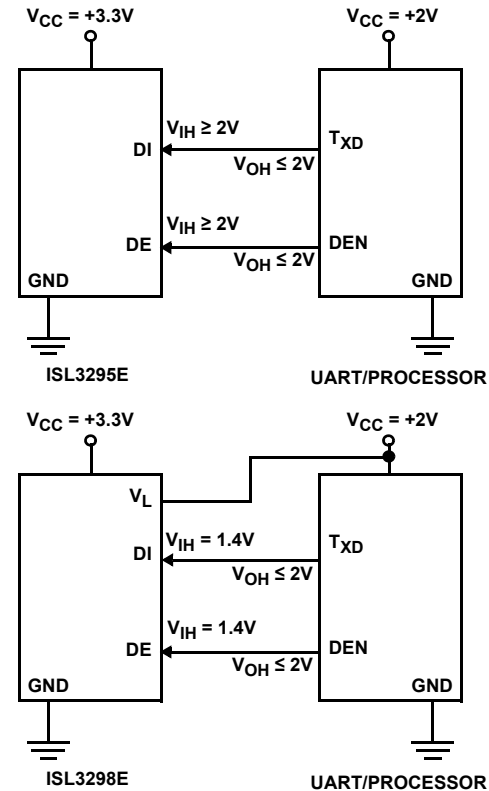

FIGURE 8. USING V_L PIN TO ADJUST LOGIC LEVELS

V_L can be anywhere from V_{CC} down to 1.35V, but the input switching points may not provide enough noise margin and 20Mbps data rates may not be achievable, when $V_L < 1.5V$. [Table 2](#) indicates typical V_{IH} and V_{IL} values for various V_L settings so you can ascertain whether or not a particular V_L voltage meets his needs.

TABLE 2. V_{IH} AND V_{IL} vs V_L FOR $V_{CC} = 3.3V$ OR $5V$

V_L (V)	V_{IH} (V)	V_{IL} (V)
1.35	0.7	0.4
1.5	0.8	0.5
1.8	0.9	0.7
2.3	1.1	1.0
2.7	1.3	1.1
3.3	1.5	1.4
5.0 (i.e., V_{CC})	2.7	2.3

The V_L supply current (I_L) is typically much less than 20 μ A, as shown in [Figure 12 on page 11](#), when DE and DI are above/below V_{IH}/V_{IL} .

Hot Plug Function

When a piece of equipment powers up, there is a period of time where the processor or ASIC driving the RS-485 control line (DE) is unable to ensure that the RS-485 Tx outputs are kept disabled. If the equipment is connected to the bus, a driver activating prematurely during power-up can crash the bus. To avoid this scenario, the ISL329xE family incorporates a “Hot Plug” function. During power-up, circuitry monitoring V_{CC} ensures that the Tx outputs remain disabled for a period of time, regardless of the state of DE. This gives the processor/ASIC a chance to stabilize and drive the RS-485 control lines to the proper states.

ESD Protection

All pins on these devices include class 3 (8kV) Human Body Model (HBM) ESD protection structures, but the RS-485 pins (driver outputs) incorporate advanced structures allowing them to survive ESD events in excess of $\pm 16.5\text{kV}$ HBM and $\pm 7\text{kV}$ to the IEC61000 contact test method. The RS-485 pins are particularly vulnerable to ESD damage because they typically connect to an exposed port on the exterior of the finished product. Simply touching the port pins, or connecting a cable, can cause an ESD event that might destroy unprotected ICs. These new ESD structures protect the device whether or not it is powered up and without degrading the RS-485 common-mode range of -7V to +12V. This built-in ESD protection eliminates the need for board level protection structures (such as transient suppression diodes) and the associated, undesirable capacitive load they present.

Data Rate, Cables and Terminations

The length of RS-485/RS-422 networks operating at 20Mbps is limited to less than 100'. Twisted pair is the cable of choice for RS-485/RS-422 networks. Twisted pair cables tend to pick up noise and other electromagnetically induced voltages as common-mode signals, which are effectively rejected by the differential receivers in these ICs.

Proper termination is imperative to minimize reflections. In point-to-point, or point-to-multipoint (single driver on bus) networks, the main cable should be terminated in its characteristic impedance (typically 120Ω) at the end farthest from the driver. In multireceiver applications, stubs connecting receivers to the main cable should be kept as short as possible. Multipoint (multidriver) systems require that the main cable be terminated in its characteristic impedance at both ends. Stubs connecting a transmitter or receiver to the main cable should be kept as short as possible.

Driver Overload Protection

As stated previously, the RS-485 specification requires that drivers survive worst case bus contentions undamaged. These drivers meet this requirement, for $V_{CC} \leq 3.6\text{V}$, via driver output short-circuit current limits and on-chip thermal shutdown circuitry.

The driver output stages incorporate short-circuit current limiting circuitry, which ensures that the output current never exceeds the RS-485 specification, for $V_{CC} \leq 3.6\text{V}$, even at the common-mode voltage range extremes. Additionally, these devices utilize a foldback circuit which reduces the short-circuit current and thus the power dissipation, whenever the contending voltage exceeds either V_{CC} or GND.

In the event of a major short-circuit condition, devices also include a thermal shutdown feature that disables the drivers whenever the die temperature becomes excessive. This eliminates the power dissipation, allowing the die to cool. The drivers automatically reenables after the die temperature drops about $+20^\circ\text{C}$. If the contention persists, the thermal shutdown/reenable cycle repeats until the fault is cleared.

At $V_{CC} > 3.6\text{V}$, the instantaneous short-circuit current is high enough that output stage damage can occur during short-circuit conditions to voltages outside of GND to V_{CC} , before the short-circuit limiting and thermal shutdown activate. For $V_{CC} = 5\text{V}$ operation, if output short-circuits are a possibility (for example, due to bus contention), it is recommended that a 5Ω resistor be inserted in series with each output. This resistor limits the instantaneous current below levels that can cause damage. The driver V_{OD} at $V_{CC} = 5\text{V}$ is so large that this small added resistance has little impact.

High Temperature Operation

Due to power dissipation and instantaneous output short-circuit current levels at $V_{CC} = 5\text{V}$, these transmitters may not be operated at $+125^\circ\text{C}$ with $V_{CC} > 3.6\text{V}$.

At $V_{CC} = 3.6\text{V}$, even the SOT-23 versions may be operated at $+125^\circ\text{C}$, while driving a 100', double terminated, CAT 5 cable at 20Mbps, without triggering the thermal SHDN circuit.

Low Power Shutdown Mode

These BiCMOS transmitters all use a fraction of the power required by their bipolar counterparts, but they also include a shutdown feature that reduces the already low quiescent I_{CC} to a $1\mu\text{A}$ trickle. These devices enter shutdown whenever the driver disables (DE = GND).

Typical Performance Curves

$V_{CC} = V_L = 3.3V$, $T_A = +25^\circ C$, unless otherwise specified.

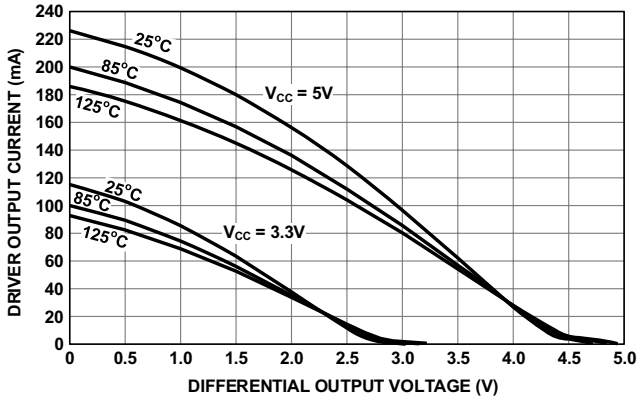

FIGURE 9. DRIVER OUTPUT CURRENT vs DIFFERENTIAL OUTPUT VOLTAGE

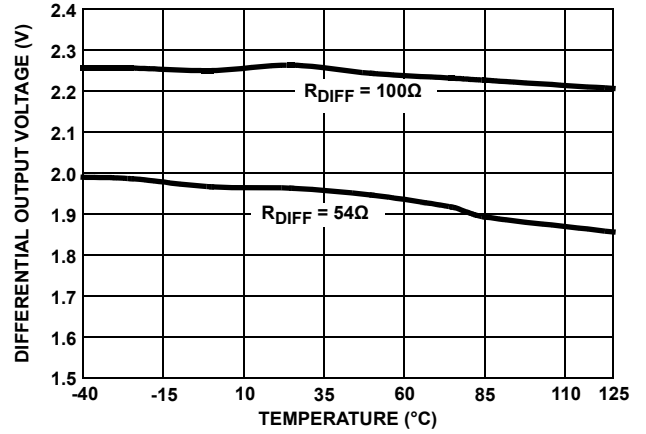

FIGURE 10. DRIVER DIFFERENTIAL OUTPUT VOLTAGE vs TEMPERATURE

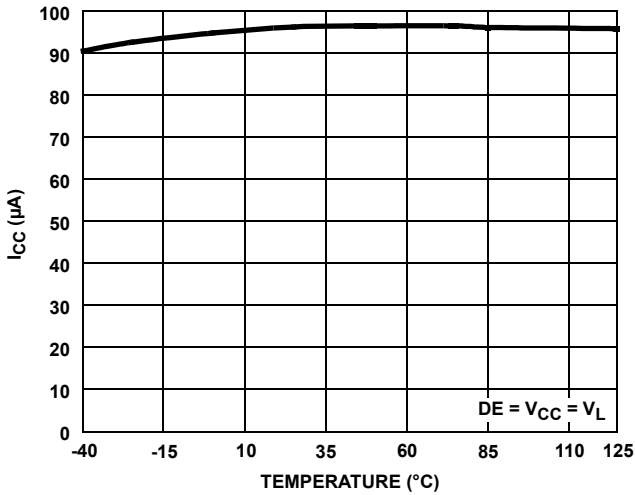

FIGURE 11. SUPPLY CURRENT vs TEMPERATURE

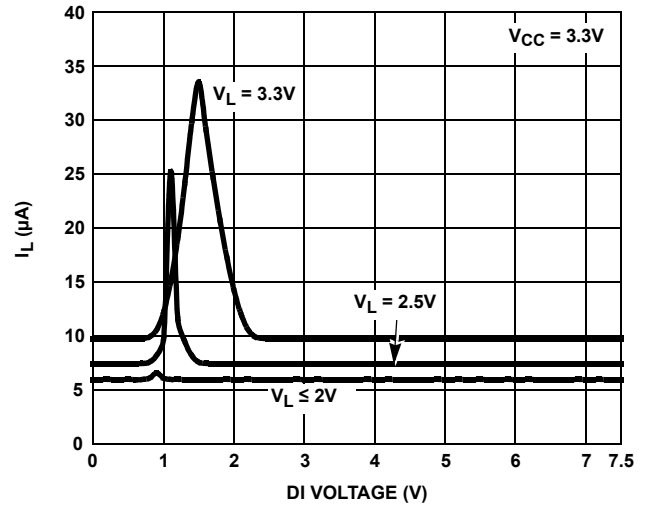

FIGURE 12. V_L SUPPLY CURRENT vs LOGIC PIN VOLTAGE

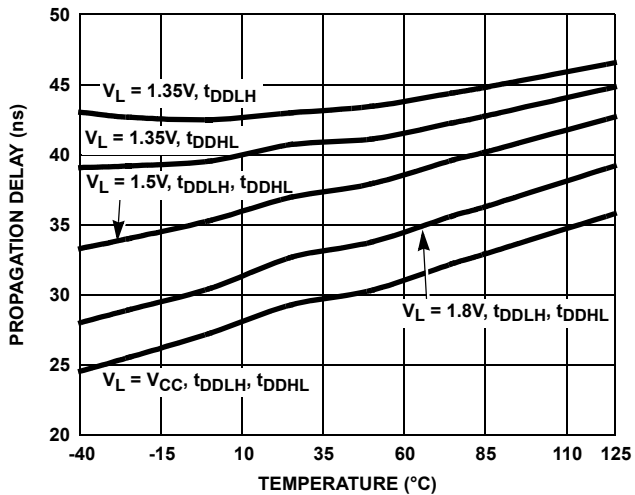

FIGURE 13. DRIVER DIFFERENTIAL PROPAGATION DELAY vs TEMPERATURE

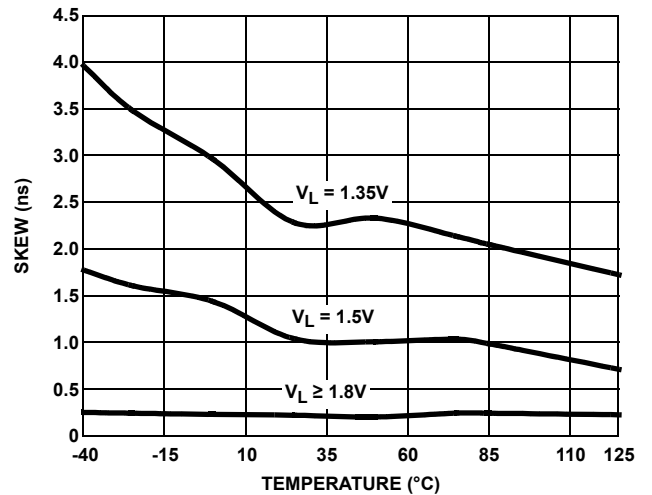

FIGURE 14. DRIVER DIFFERENTIAL SKEW vs TEMPERATURE

$V_{CC} = V_L = 3.3V$, $T_A = +25^\circ C$, unless otherwise specified. (Continued)

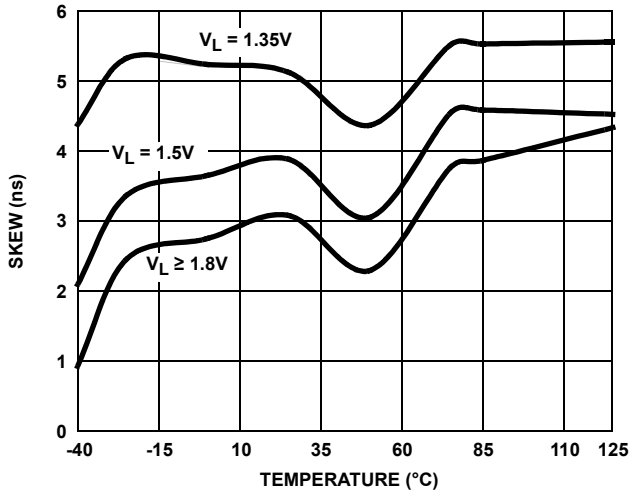

FIGURE 15. DRIVER SINGLE-ENDED SKEW vs TEMPERATURE

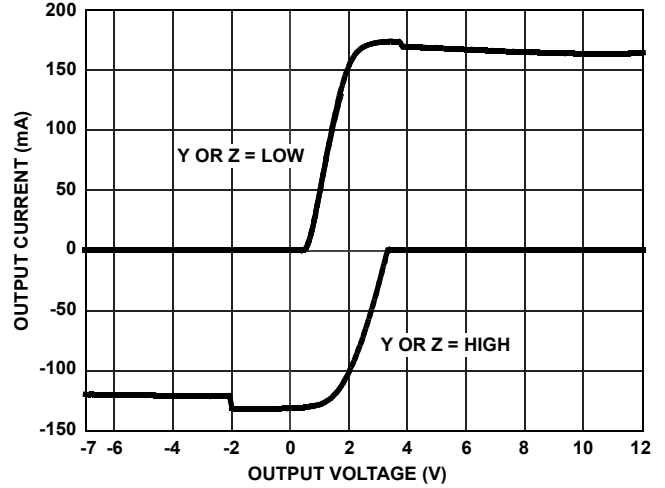

FIGURE 16. DRIVER OUTPUT CURRENT vs SHORT-CIRCUIT VOLTAGE

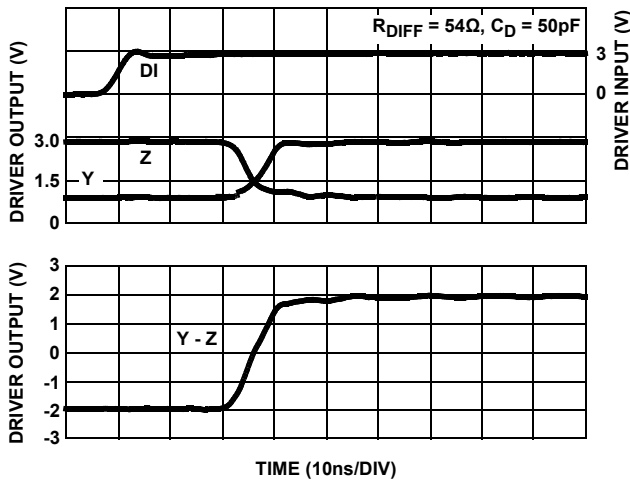

FIGURE 17. DRIVER WAVEFORMS, LOW-TO-HIGH

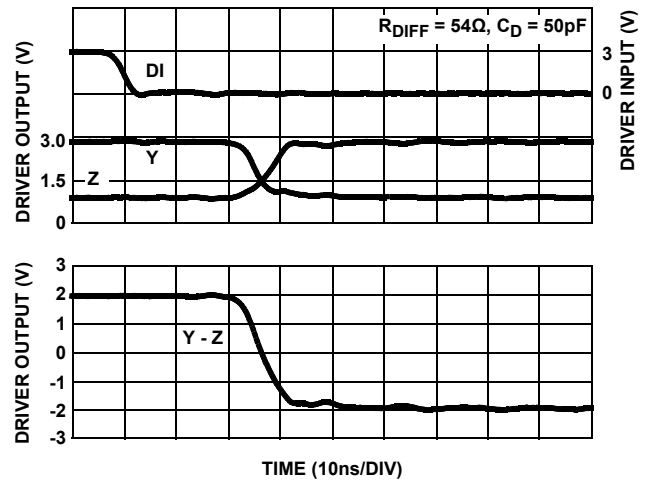

FIGURE 18. DRIVER WAVEFORMS, HIGH-TO-LOW

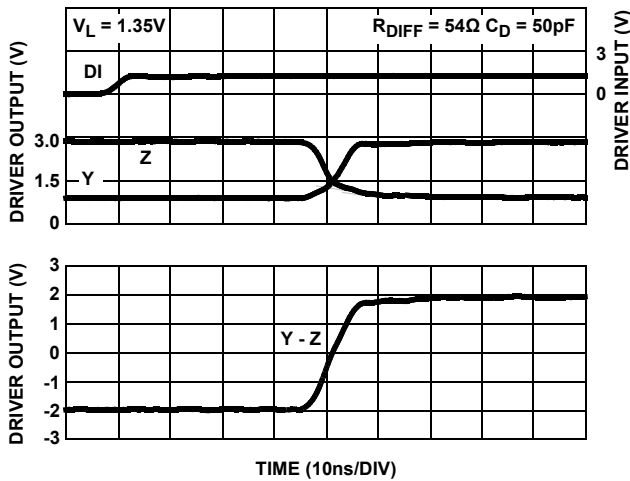

FIGURE 19. DRIVER WAVEFORMS, LOW-TO-HIGH

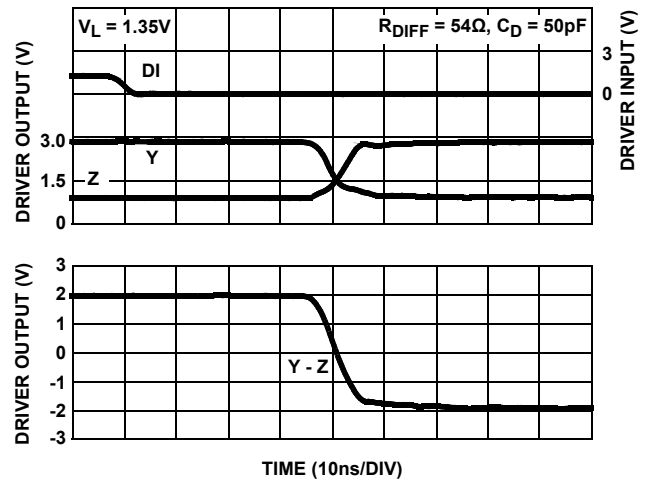

FIGURE 20. DRIVER WAVEFORMS, HIGH-TO-LOW

Die Characteristics

SUBSTRATE AND TDFN THERMAL PAD POTENTIAL (POWERED UP):

GND

TRANSISTOR COUNT:

516

PROCESS:

Si Gate BiCMOS

Revision History

The revision history provided is for informational purposes only and is believed to be accurate, but not warranted. Please go to the web to make sure that you have the latest revision.

DATE	REVISION	CHANGE
Oct 9, 2019	FN6544.4	Updated links throughout. Removed ISL3293E, ISL3294E, ISL3296E, and ISL3297E information from document. Updated Pin Configuration diagrams Updated ordering information table by adding tape and reel quantity column and updating notes. Updated Figure 9. Removed About Intersil section Updated Disclaimer.
Sep 25, 2015	FN6544.3	On page 1, table 1, for ISL3293E entry, added "Recommended replacement: ISL32613E" after "No longer available or supported". For ISL3294E entry, added "Recommended replacement: ISL32614E" after "No longer available or supported". On page 3, "Ordering Information" table, for ISL3293E entries (rows 1 and 2), added "Recommended replacement: ISL32613E" after "No longer available or supported". For ISL3294E entries (rows 3 and 4), added "Recommended replacement: ISL32614E" after "No longer available or supported".
Jul 27, 2015	FN6544.2	Table 1 Summary of Features on page 1, added "No longer available or supported" to ISL3293E, ISL3294E, ISL3296E, ISL3297E. Ordering Information table on page 3, added "No longer available or supported" to the following parts: ISL3293E and ISL3294E (1st 4 rows) and to ISL3296E and ISL3297E (rows 7-10). Electrical Spec table, added "(Parts no longer available or supported)" to DRIVER SWITCHING CHARACTERISTICS sections on page 6 (for parts ISL3293E, ISL3296E and ISL3294E, ISL3297E). POD on page 16, updated from ref 1 to rev 2. Changes since rev 1: Tiebar Note updated From: Tiebar shown (if present) is a non-functional feature. To: Tiebar shown (if present) is a non-functional feature and may be located on any of the 4 sides (or ends).
Dec 11, 2014	FN6544.1	Updated entire datasheet to Intersil new standard. Added text in several places to clarify that VL can be connected to Vcc. Updated PODs P6.064 and L8.2x3A to latest revisions with changes as follows: Updated to new POD format by removing table listing dimensions and moving dimensions onto drawing. Added Typical Recommended Land Pattern.
Sep 19, 2007	FN6544.0	Initial Release.

Package Outline Drawings

For the most recent package outline drawing, see [P6.064](#).

P6.064
 6 LEAD SMALL OUTLINE TRANSISTOR PLASTIC PACKAGE
 Rev 4, 2/10

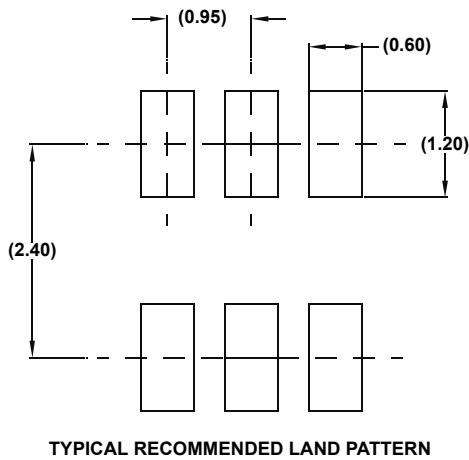
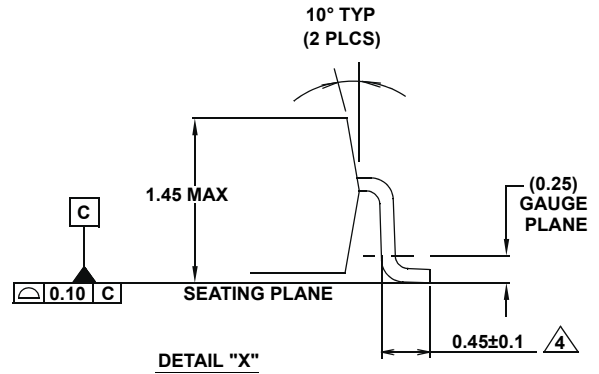
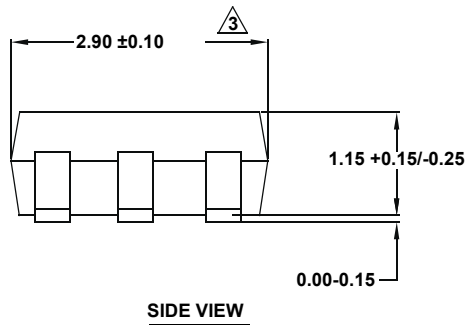
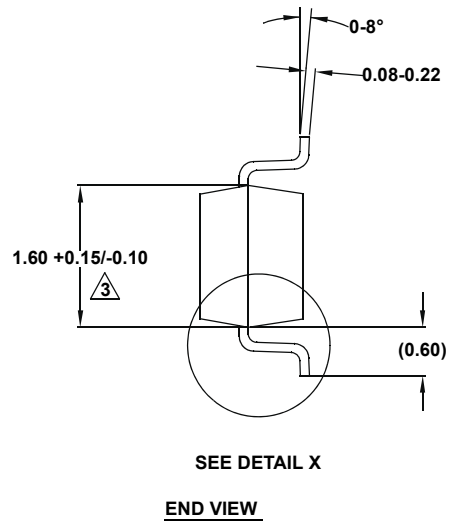
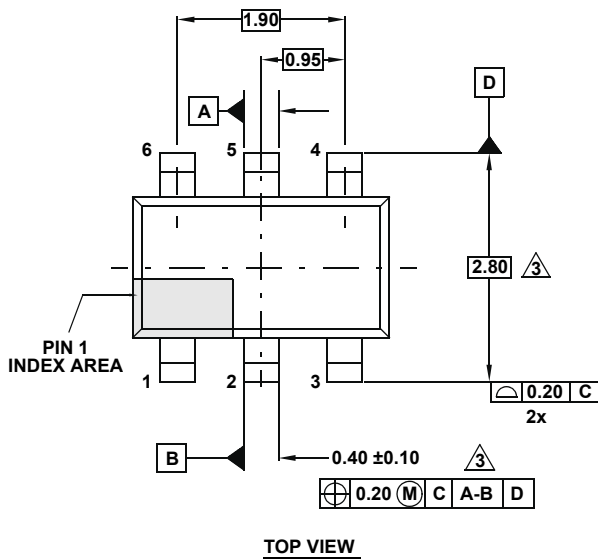

NOTES:

1. Dimensions are in millimeters.
 Dimensions in () for Reference Only.
2. Dimensioning and tolerancing conform to ASME Y14.5M-1994.
3. Dimension is exclusive of mold flash, protrusions or gate burrs.
4. Foot length is measured at reference to gauge plane.
5. Package conforms to JEDEC MO-178AB.

L8.2x3A
8 LEAD THIN DUAL FLAT NO-LEAD PLASTIC PACKAGE WITH E-PAD
 Rev 2, 05/15

For the most recent package outline drawing, see [L8.2x3A](#).

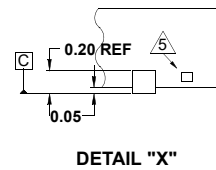
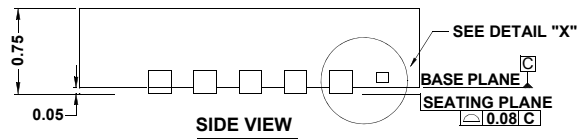
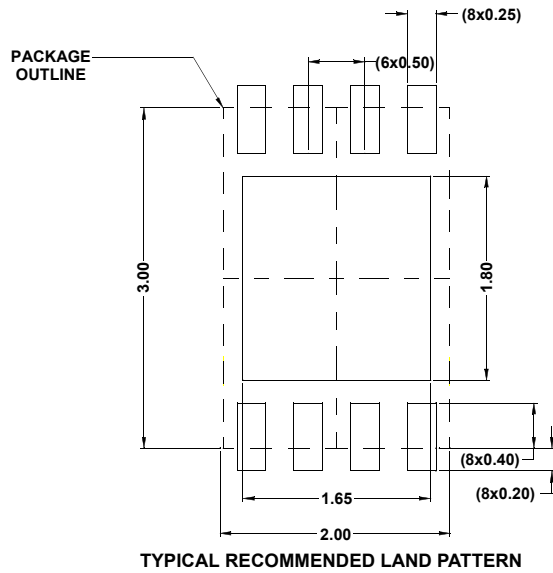
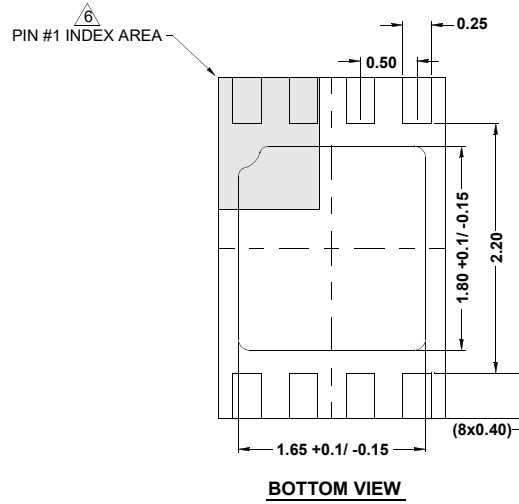
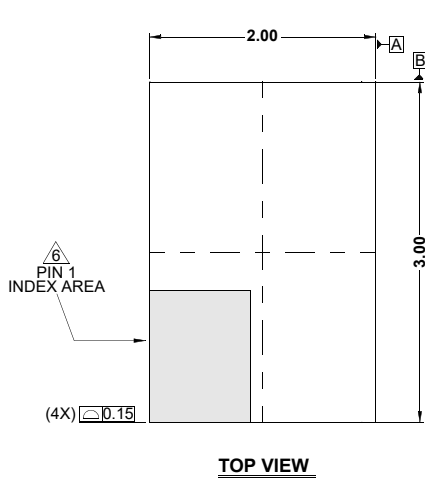

NOTES:

1. Dimensions are in millimeters.
Dimensions in () for Reference Only.
2. Dimensioning and tolerancing conform to ASME Y14.5m-1994.
3. Unless otherwise specified, tolerance : Decimal ± 0.05
4. Dimension b applies to the metallized terminal and is measured between 0.20mm and 0.32mm from the terminal tip.
5. Tiebar shown (if present) is a non-functional feature and may be located on any of the 4 sides (or ends).
6. The configuration of the pin #1 identifier is optional, but must be located within the zone indicated. The pin #1 identifier may be either a mold or mark feature.

Notice

1. Descriptions of circuits, software and other related information in this document are provided only to illustrate the operation of semiconductor products and application examples. You are fully responsible for the incorporation or any other use of the circuits, software, and information in the design of your product or system. Renesas Electronics disclaims any and all liability for any losses and damages incurred by you or third parties arising from the use of these circuits, software, or information.
2. Renesas Electronics hereby expressly disclaims any warranties against and liability for infringement or any other claims involving patents, copyrights, or other intellectual property rights of third parties, by or arising from the use of Renesas Electronics products or technical information described in this document, including but not limited to, the product data, drawings, charts, programs, algorithms, and application examples.
3. No license, express, implied or otherwise, is granted hereby under any patents, copyrights or other intellectual property rights of Renesas Electronics or others.
4. You shall not alter, modify, copy, or reverse engineer any Renesas Electronics product, whether in whole or in part. Renesas Electronics disclaims any and all liability for any losses or damages incurred by you or third parties arising from such alteration, modification, copying or reverse engineering.
5. Renesas Electronics products are classified according to the following two quality grades: "Standard" and "High Quality". The intended applications for each Renesas Electronics product depends on the product's quality grade, as indicated below.
 - "Standard": Computers; office equipment; communications equipment; test and measurement equipment; audio and visual equipment; home electronic appliances; machine tools; personal electronic equipment; industrial robots; etc.
 - "High Quality": Transportation equipment (automobiles, trains, ships, etc.); traffic control (traffic lights); large-scale communication equipment; key financial terminal systems; safety control equipment; etc.Unless expressly designated as a high reliability product or a product for harsh environments in a Renesas Electronics data sheet or other Renesas Electronics document, Renesas Electronics products are not intended or authorized for use in products or systems that may pose a direct threat to human life or bodily injury (artificial life support devices or systems; surgical implantations; etc.), or may cause serious property damage (space system; undersea repeaters; nuclear power control systems; aircraft control systems; key plant systems; military equipment; etc.). Renesas Electronics disclaims any and all liability for any damages or losses incurred by you or any third parties arising from the use of any Renesas Electronics product that is inconsistent with any Renesas Electronics data sheet, user's manual or other Renesas Electronics document.
6. When using Renesas Electronics products, refer to the latest product information (data sheets, user's manuals, application notes, "General Notes for Handling and Using Semiconductor Devices" in the reliability handbook, etc.), and ensure that usage conditions are within the ranges specified by Renesas Electronics with respect to maximum ratings, operating power supply voltage range, heat dissipation characteristics, installation, etc. Renesas Electronics disclaims any and all liability for any malfunctions, failure or accident arising out of the use of Renesas Electronics products outside of such specified ranges.
7. Although Renesas Electronics endeavors to improve the quality and reliability of Renesas Electronics products, semiconductor products have specific characteristics, such as the occurrence of failure at a certain rate and malfunctions under certain use conditions. Unless designated as a high reliability product or a product for harsh environments in a Renesas Electronics data sheet or other Renesas Electronics document, Renesas Electronics products are not subject to radiation resistance design. You are responsible for implementing safety measures to guard against the possibility of bodily injury, injury or damage caused by fire, and/or danger to the public in the event of a failure or malfunction of Renesas Electronics products, such as safety design for hardware and software, including but not limited to redundancy, fire control and malfunction prevention, appropriate treatment for aging degradation or any other appropriate measures. Because the evaluation of microcomputer software alone is very difficult and impractical, you are responsible for evaluating the safety of the final products or systems manufactured by you.
8. Please contact a Renesas Electronics sales office for details as to environmental matters such as the environmental compatibility of each Renesas Electronics product. You are responsible for carefully and sufficiently investigating applicable laws and regulations that regulate the inclusion or use of controlled substances, including without limitation, the EU RoHS Directive, and using Renesas Electronics products in compliance with all these applicable laws and regulations. Renesas Electronics disclaims any and all liability for damages or losses occurring as a result of your noncompliance with applicable laws and regulations.
9. Renesas Electronics products and technologies shall not be used for or incorporated into any products or systems whose manufacture, use, or sale is prohibited under any applicable domestic or foreign laws or regulations. You shall comply with any applicable export control laws and regulations promulgated and administered by the governments of any countries asserting jurisdiction over the parties or transactions.
10. It is the responsibility of the buyer or distributor of Renesas Electronics products, or any other party who distributes, disposes of, or otherwise sells or transfers the product to a third party, to notify such third party in advance of the contents and conditions set forth in this document.
11. This document shall not be reprinted, reproduced or duplicated in any form, in whole or in part, without prior written consent of Renesas Electronics.
12. Please contact a Renesas Electronics sales office if you have any questions regarding the information contained in this document or Renesas Electronics products.

(Note1) "Renesas Electronics" as used in this document means Renesas Electronics Corporation and also includes its directly or indirectly controlled subsidiaries.

(Note2) "Renesas Electronics product(s)" means any product developed or manufactured by or for Renesas Electronics.

(Rev.4.0-1 November 2017)

Corporate Headquarters

TOYOSU FORESIA, 3-2-24 Toyosu,
Koto-ku, Tokyo 135-0061, Japan
www.renesas.com

Contact Information

For further information on a product, technology, the most up-to-date version of a document, or your nearest sales office, please visit:
www.renesas.com/contact/

Trademarks

Renesas and the Renesas logo are trademarks of Renesas Electronics Corporation. All trademarks and registered trademarks are the property of their respective owners.