

THIS DRAWING IS UNPUBLISHED. RELEASED FOR PUBLICATION
 © COPYRIGHT 19 BY AMP INCORPORATED. ALL RIGHTS RESERVED.

LOC		DIST		REVISIONS			
P	LTR	DESCRIPTION		DATE	DWN	APVD	
E		REV & REDRAWN; 0600-5878-96		11-96	CT	CS	

WIRING TABLE	
POSITION NO.	WIRE COLOR
1	BROWN
2	RED
3	ORANGE
4	YELLOW
5	GREEN

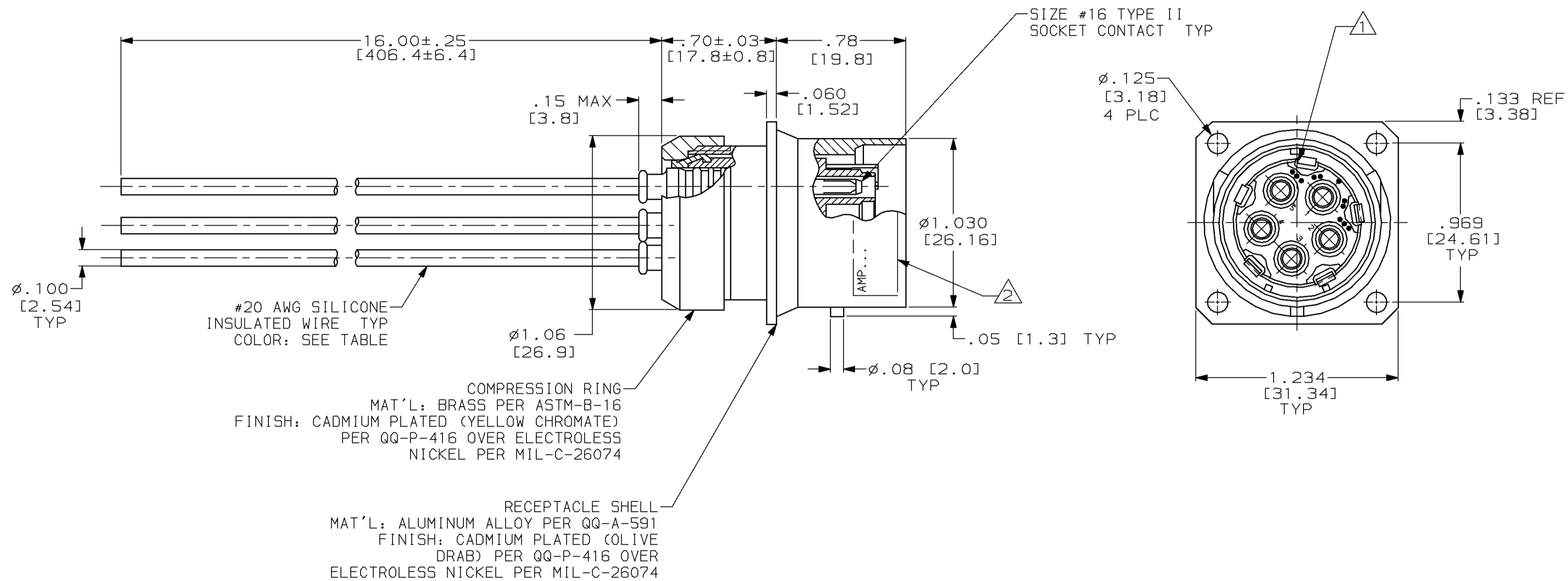

- 1 TRIPLE DOT FOR NORMAL POLARIZATION LOCATED UNDER MAJOR KEYWAY.
- 2 AMP INFO MARKED PER MIL-STD-130.
- 3. MAXIMUM MOUNTING PANEL THICKNESS: .100 [2.54].
- 4. WORKING VOLTAGE IS 4.5 KVDC MAX WHEN PROPERLY MATED.

863985-1
 PART NO.

THIS DRAWING IS A CONTROLLED DOCUMENT.		DWN C.C. THOMAS 11-18-96	AMP Incorporated Harrisburg, PA 17105-3608	
DIMENSIONS: INCHES [mm]		CHK C. SHELLY 11-19-96	NAME CABLE ASSY, 5 POSN, LGH	
TOLERANCES UNLESS OTHERWISE SPECIFIED:		APVD C. SHELLY 11-19-96	RESTRICTED TO	
0 PLC ±		PRODUCT SPEC	SIZE CAGE CODE DRAWING NO	
1 PLC ±		APPLICATION SPEC	A2 00779 C-863985	
2 PLC ±.02 [0.5]		WEIGHT	SCALE SHEET OF REV	
3 PLC ±.010 [0.25]		CUSTOMER DRAWING	2:1 1 OF 1 E	
4 PLC ±				
ANGLES ±				
FINISH -				