

National Semiconductor is now part of
Texas Instruments.

Search <http://www.ti.com/> for the latest technical
information and details on our current products and services.

LM3411 Precision Secondary Regulator/Driver

General Description

The LM3411 is a low power fixed-voltage (3.3V or 5.0V) precision shunt regulator designed specifically for driving an optoisolator to provide feedback isolation in a switching regulator.

The LM3411 circuitry includes an internally compensated op amp, a bandgap reference, NPN output transistor, and voltage setting resistors.

A trimmed precision bandgap reference with temperature drift curvature correction, provides a guaranteed 1% precision over the operating temperature range (A grade version). The amplifier's inverting input is externally accessible for loop frequency compensation when used as part of a larger servo system. The output is an open-emitter NPN transistor capable of driving up to 15 mA of load current.

Because of its small die size, one of the available packages is the sub-miniature 5-lead SOT23-5 surface mount package. This package is ideal for use in space critical applications.

Although its main application is to provide a precision output voltage (no trimming required) and maintain very good regulation in isolated DC/DC converters, it can also be used with

other types of voltage regulators or power semiconductors to provide a precision output voltage without precision resistors or trimming.

Features

- Fixed voltages of 3.3V and 5.0V with initial tolerance of $\pm 1\%$ for standard grade and $\pm 0.5\%$ for A grade
- Custom voltages available (3V–17V)
- Wide output current range, 20 μA –15 mA
- Low temperature coefficient
- Available in 8-pin DIP and 5-lead SOT23-5 surface mount package (tape and reel)

Applications

- Secondary controller for isolated DC/DC PWM switching regulators systems
- Use with LDO regulator for high-precision fixed output regulators
- Precision monitoring applications
- Use with many types of regulators to increase precision and improve performance

Typical Application and Functional Diagram

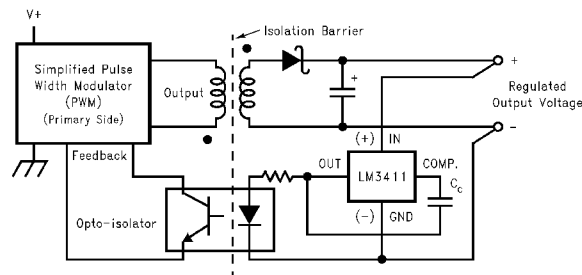

DS011987-1

Basic Isolated DC/DC Converter

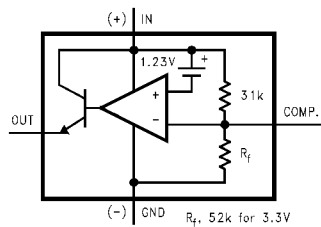

DS011987-2

LM3411 Functional Diagram

SIMPLE SWITCHER™ is a trademark of National Semiconductor Corporation.

Connection Diagrams and Order Information

5-Lead Small Outline Package (M5)

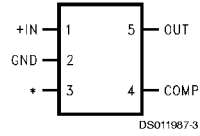

*No internal connection, but should be soldered to PC board for best heat transfer.

Top View

Actual Size



For Ordering Information
See *Figure 1* in this Data Sheet
See NS Package Number MA05A

8-Lead Dual-In-Line Package (N)

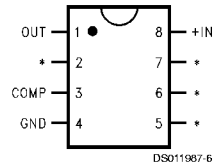

*No internal connection, but should be soldered to PC board for best heat transfer.

Top View

Actual Size



Order Number LM3411N-3.3, LM3411AN-3.3,
L3411N-5.0 or LM3411AN-5.0
See NS Package Number N08E

Absolute Maximum Ratings (Note 1)

If Military/Aerospace specified devices are required, please contact the National Semiconductor Sales Office/Distributors for availability and specifications.

Input Voltage V(IN)	20V
Output Current	20 mA
Junction Temperature	150°C
Storage Temperature	-65°C to +150°C
Lead Temperature	
M5 Package	
Vapor Phase (60 sec.)	+215°C
Infrared (15 sec.)	+220°C
N Package Soldering (10 sec.)	
	+260°C
Power Dissipation (T _A = 25°C) (Note 2)	

M5 Package	300 mW
N Package	600 mW
ESD Susceptibility (Note 3)	
Human Body Model	1500V
See AN-450 "Surface Mounting Methods and Their Effect on Product Reliability" for methods on soldering surface-mount devices.	

Operating Ratings (Notes 1, 2)

Ambient Temperature Range	-40°C ≤ T _A ≤ +85°C
Junction Temperature Range	-40°C ≤ T _J ≤ +125°C
Output Current	15 mA

LM3411-3.3 Electrical Characteristics

Specifications with standard type face are for T_J = 25°C, and those with **boldface type** apply over **full Operating Temperature Range**. Unless otherwise specified, V(IN) = V_{REG}, V_{OUT} = 1.5V.

Symbol	Parameter	Conditions	Typical (Note 4)	LM3411A-3.3 Limit (Note 5)	LM3411-3.3 Limit (Note 5)	Units (Limits)
V _{REG}	Regulation Voltage	I _{OUT} = 5 mA	3.3	3.317/ 3.333 3.284/ 3.267	3.333/ 3.366 3.267/ 3.234	V V(max) V(min)
	Regulation Voltage Tolerance	I _{OUT} = 5 mA		±0.5/ ±1	±1/ ±2	%(max)
I _q	Quiescent Current	I _{OUT} = 5 mA	85	110/ 115	125/ 150	μA μA(max)
G _m	Transconductance ΔI _{OUT} /ΔV _{REG}	20 μA ≤ I _{OUT} ≤ 1 mA	3.3	1.5/ 0.75	1/ 0.50	mA/mV mA/mV(min)
		1 mA ≤ I _{OUT} ≤ 15 mA	6.0	3.3/ 2.0	2.5/ 1.7	mA/mV mA/mV(min)
A _v	Voltage Gain ΔV _{OUT} /ΔV _{REG}	1V ≤ V _{OUT} ≤ V _{REG} - 1.2V (-1.3) R _L = 140Ω (Note 6)	1000	550/ 250	450/ 200	V/V V/V(min)
		1V ≤ V _{OUT} ≤ V _{REG} - 1.2V (-1.3) R _L = 2 kΩ	3500	1500/ 900	1000/ 700	V/V V/V(min)
V _{SAT}	Output Saturation (Note 7)	V(IN) = V _{REG} +100 mV I _{OUT} = 15 mA	1.0	1.2/ 1.3	1.2/ 1.3	V V(max)
I _L	Output Leakage Current	V(IN) = V _{REG} -100 mV V _{OUT} = 0V	0.1	0.5/ 1.0	0.5/ 1.0	μA μA(max)
R _f	Internal Feedback Resistor (Note 8)		52	65 39	65 39	kΩ kΩ(max) kΩ(min)
E _n	Output Noise Voltage	I _{OUT} = 1 mA, 10 Hz ≤ f ≤ 10 kHz	50			μV _{RMS}

LM3411-5.0 Electrical Characteristics

Specifications with standard type face are for $T_J = 25^\circ\text{C}$, and those with **boldface type** apply over **full Operating Temperature Range**. Unless otherwise specified, $V(\text{IN}) = V_{\text{REG}}$, $V_{\text{OUT}} = 1.5\text{V}$.

Symbol	Parameter	Conditions	Typical (Note 4)	LM3411A-5.0 Limit (Note 5)	LM3411-5.0 Limit (Note 5)	Units (Limits)
V_{REG}	Regulation Voltage	$I_{\text{OUT}} = 5\text{ mA}$	5	5.025/ 5.050 4.975/ 4.950	5.050/ 5.100 4.950/ 4.900	V V(max) V(min)
	Regulation Voltage Tolerance	$I_{\text{OUT}} = 5\text{ mA}$		$\pm 0.5/\pm 1$	$\pm 1/\pm 2$	%(max)
I_q	Quiescent Current	$I_{\text{OUT}} = 5\text{ mA}$	85	110/ 115	125/ 150	μA $\mu\text{A}(\text{max})$
G_m	Transconductance $\Delta I_{\text{OUT}}/\Delta V_{\text{REG}}$	$20\ \mu\text{A} \leq I_{\text{OUT}} \leq 1\text{ mA}$	3.3	1.5/ 0.75	1.0/ 0.5	mA/mV $\text{mA}/\text{mV}(\text{min})$
		$1\text{ mA} \leq I_{\text{OUT}} \leq 15\text{ mA}$	6.0	3.3/2.0	2.5/1.7	mA/mV $\text{mA}/\text{mV}(\text{min})$
A_v	Voltage Gain $\Delta V_{\text{OUT}}/\Delta V_{\text{REG}}$	$1\text{V} \leq V_{\text{OUT}} \leq V_{\text{REG}} - 1.2\text{V}$ (-1.3) $R_L = 250\ \Omega$ (Note 6)	1000	750/ 350	650/ 300	V/V V/V(min)
		$1\text{V} \leq V_{\text{OUT}} \leq V_{\text{REG}} - 1.2\text{V}$ (-1.3) $R_L = 2\text{ k}\Omega$	3500	1500/ 900	1000/ 700	V/V V/V(min)
V_{SAT}	Output Saturation (Note 7)	$V(\text{IN}) = V_{\text{REG}} + 100\text{ mV}$ $I_{\text{OUT}} = 15\text{ mA}$	1.0	1.2/ 1.3	1.2/ 1.3	V V(max)
I_L	Output Leakage Current	$V(\text{IN}) = V_{\text{REG}} - 100\text{ mV}$ $V_{\text{OUT}} = 0\text{V}$	0.1	0.5/ 1.0	0.5/ 1.0	μA $\mu\text{A}(\text{max})$
R_f	Internal Feedback Resistor (Note 8)		94	118	118	$\text{k}\Omega$ $\text{k}\Omega(\text{max})$
				70	70	$\text{k}\Omega(\text{min})$
E_n	Output Noise Voltage	$I_{\text{OUT}} = 1\text{ mA}$, $10\text{ Hz} \leq f \leq 10\text{ kHz}$	80			μV_{RMS}

Note 1: Absolute Maximum Ratings indicate limits beyond which damage to the device may occur. Operating Ratings indicate conditions for which the device is intended to be functional, but do not guarantee specific performance limits. For guaranteed specifications and test conditions, see the Electrical Characteristics. The guaranteed specifications apply only for the test conditions listed. Some performance characteristics may degrade when the device is not operated under the listed test conditions.

Note 2: The maximum power dissipation must be derated at elevated temperatures and is dictated by T_{Jmax} (maximum junction temperature), θ_{JA} (junction to ambient thermal resistance), and T_{A} (ambient temperature). The maximum allowable power dissipation at any temperature is $(P_{\text{Dmax}} = T_{\text{Jmax}} - T_{\text{A}})/\theta_{\text{JA}}$ or the number given in the Absolute Maximum Ratings, whichever is lower. The typical thermal resistance (θ_{JA}) when soldered to a printed circuit board is approximately $306^\circ\text{C}/\text{W}$ for the M5 package, and $100^\circ\text{C}/\text{W}$ for the N package.

Note 3: The human body model is a 100 pF capacitor discharged through a $1.5\text{ k}\Omega$ resistor into each pin.

Note 4: Typical numbers are at 25°C and represent the most likely parametric norm.

Note 5: Limits are 100% production tested at 25°C . Limits over the operating temperature range are guaranteed through correlation using Statistical Quality Control (SQC) methods. The limits are used to calculate National's Averaging Outgoing Level (AOQL).

Note 6: Actual test is done using equivalent current sink instead of a resistor load.

Note 7: $V_{\text{SAT}} = V(\text{IN}) - V_{\text{OUT}}$, when the voltage at the IN pin is forced 100 mV above the nominal regulating voltage (V_{REG}).

Note 8: See Applications and Curves sections for information on this resistor.

Typical Performance Characteristics

Normalized Temperature Drift

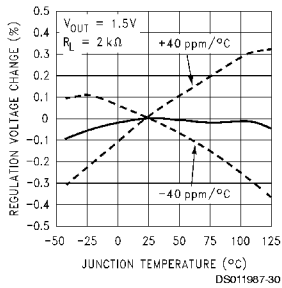

Quiescent Current

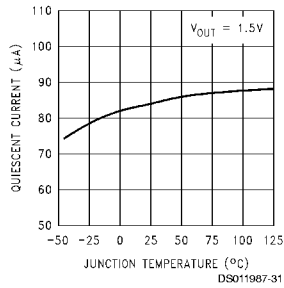

Output Saturation Voltage (V)SAT

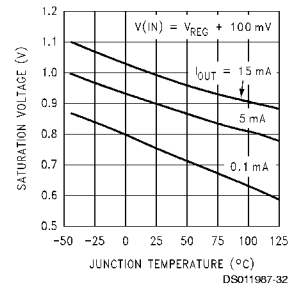

Circuit Used for Bode Plots

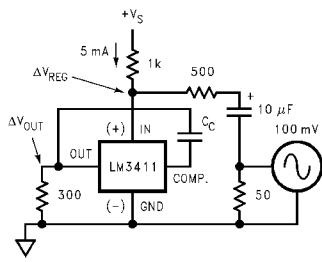

Bode Plot

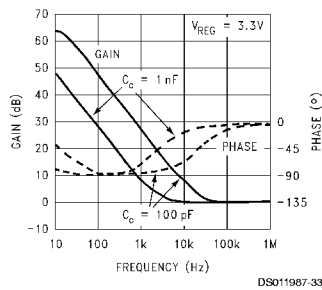

Bode Plot

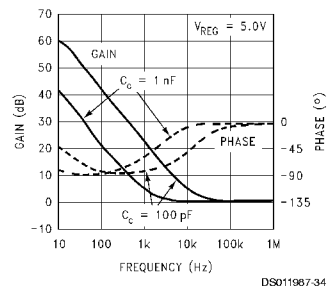

Bode Plot

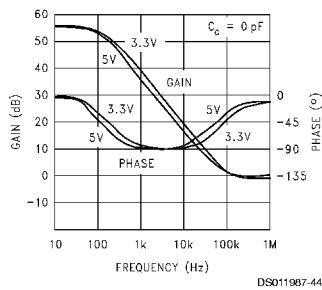

Response Time for 3.3V Version (CC = 0 pF)

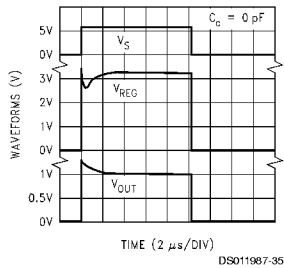

Response Time for 3.3V Version (CC = 10 nF)

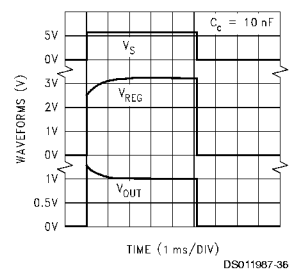

Typical Performance Characteristics (Continued)

Circuit Used for Response Time

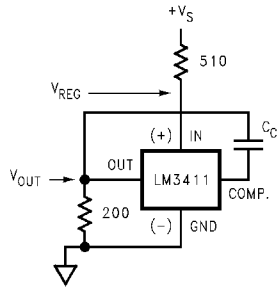

DS011987-11

Response Time for 5V Version ($C_C = 0$ pF)

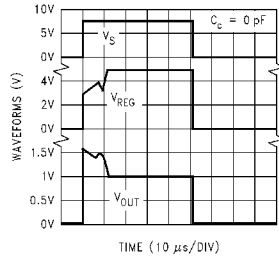

DS011987-37

Response Time for 5V Version ($C_C = 10$ nF)

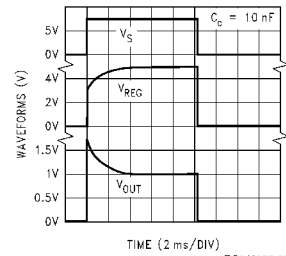

DS011987-38

Tempco of Internal Feedback Resistor (R_f)

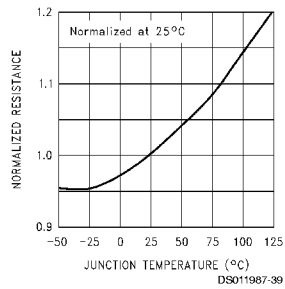

DS011987-39

Regulation Voltage Change vs Output Current

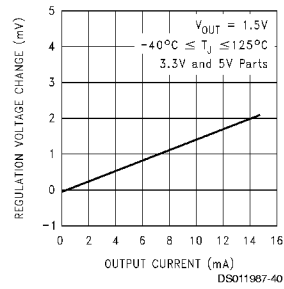

DS011987-40

Regulation Voltage vs Output Voltage and Load Resistance

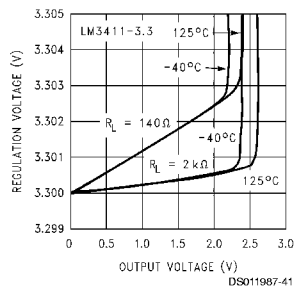

DS011987-41

Regulation Voltage vs Output Voltage and Load Resistance

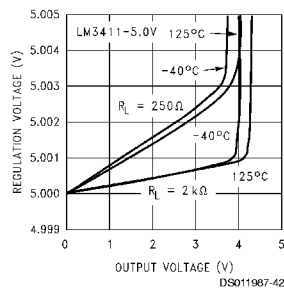

DS011987-42

Five Lead Surface Mount Package Marking and Order Information (SOT23-5)

The small SOT23-5 package allows only 4 alphanumeric characters to identify the product. The table below contains the field information marked on the package.

	Grade	Order Information	Package Marking	Supplied as
3.3V	A (Prime)	LM3411AM5-3.3	D00A	250 unit increments on tape and reel
3.3V	A (Prime)	LM3411AM5X-3.3	D00A	3K unit increments on tape and reel
3.3V	B (Standard)	LM3411M5-3.3	D00B	250 unit increments on tape and reel
3.3V	B (Standard)	LM3411M5X-3.3	D00B	3K unit increments on tape and reel
5.0V	A (Prime)	LM3411AM5-5.0	D01A	250 unit increments on tape and reel
5.0V	A (Prime)	LM3411AM5X-5.0	D01A	3K unit increments on tape and reel
5.0V	B (Standard)	LM3411M5-5.0	D01B	250 unit increments on tape and reel
5.0V	B (Standard)	LM3411M5X-5.0	D01B	3K unit increments on tape and reel

FIGURE 1. SOT23-5 Marking and Order Information

The first letter "D" identifies the part as a Driver, the next two numbers indicate the voltage, "00" for 3.3V part and "01" for a 5V part. The fourth letter indicates the grade, "B" for standard grade, "A" for the prime grade.

The SOT23-5 surface mount package is only available on tape in quantities increments of 250 on tape and reel (indicated by the letters "M5" in the part number), or in quantities increments of 3000 on tape and reel (indicated by the letters "M5X" in the part number).

Product Description

The LM3411 is a shunt regulator specifically designed to be the reference and control section in an overall feedback loop of a regulated power supply. The regulated output voltage is sensed between the IN pin and GROUND pin of the LM3411. If the voltage at the IN pin is less than the LM3411 regulating voltage (V_{REG}), the OUT pin sources no current. As the voltage at the IN pin approaches the V_{REG} voltage, the OUT pin begins sourcing current. This current is then used to drive a feedback device, (opto-coupler) or a power device, (linear regulator, switching regulator, etc.) which serves the output voltage to be the same value as V_{REG} .

In some applications, (even under normal operating conditions) the voltage on the IN pin can be forced above the V_{REG} voltage. In these instances, the maximum voltage applied to the IN pin should not exceed 20V. In addition, an external resistor may be required on the OUT pin to limit the maximum current to 20 mA.

Compensation

The inverting input of the error amplifier is brought out to allow overall closed-loop compensation. In many of the applications circuits shown here, compensation is provided by a single capacitor connected from the compensation pin to the out pin of the LM3411. The capacitor values shown in the schematics are adequate under most conditions, but they can be increased or decreased depending on the desired loop response. Applying a load pulse to the output of a regulator circuit and observing the resultant output voltage response is a easy method of determining the stability of the control loop. Analyzing more complex feedback loops requires additional information.

The formula for AC gain at a frequency (f) is as follows;

$$\text{Gain (f)} = 1 + \frac{Z_i(f)}{R_f}$$

$$\text{where } Z_i(f) = \frac{1}{j \cdot 2\pi \cdot f \cdot C}$$

where $R_f \approx 52 \text{ k}\Omega$ for the 3.3V part, and $R_f \approx 94 \text{ k}\Omega$ for the 5V part.

The resistor (R_f) in the formula is an internal resistor located on the die. Since this resistor value will affect the phase margin, the worst case maximum and minimum values are important when analyzing closed loop stability. The minimum and maximum room temperature values of this resistor are specified in the Electrical Characteristics section of this data sheet, and a curve showing the temperature coefficient is shown in the curves section. In the applications shown here, the worst case phase margin occurs with minimum values of R_f .

Test Circuit

The test circuit shown in *Figure 2* can be used to measure and verify various LM3411 parameters. Test conditions are set by forcing the appropriate voltage at the V_{OUT} . Set test point and selecting the appropriate R_L or I_{OUT} as specified in the Electrical Characteristics section. Use a DVM at the "measure" test points to read the data.

Test Circuit (Continued)

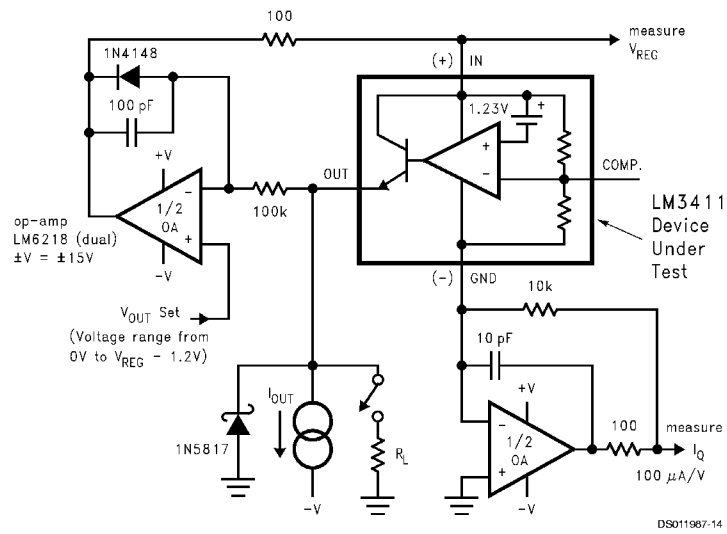

FIGURE 2. LM3411 Test Circuit

Applications Information

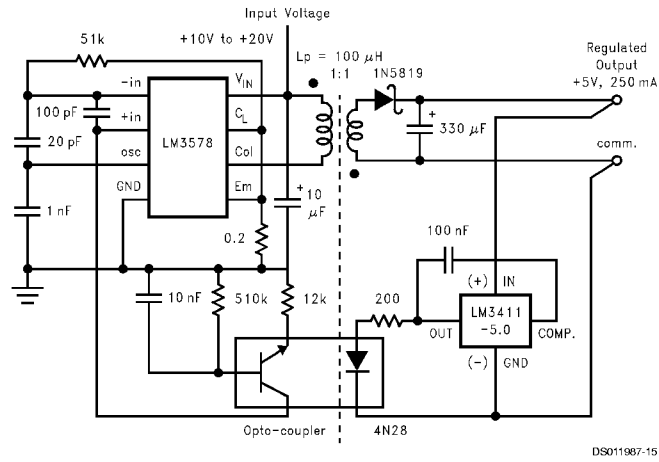
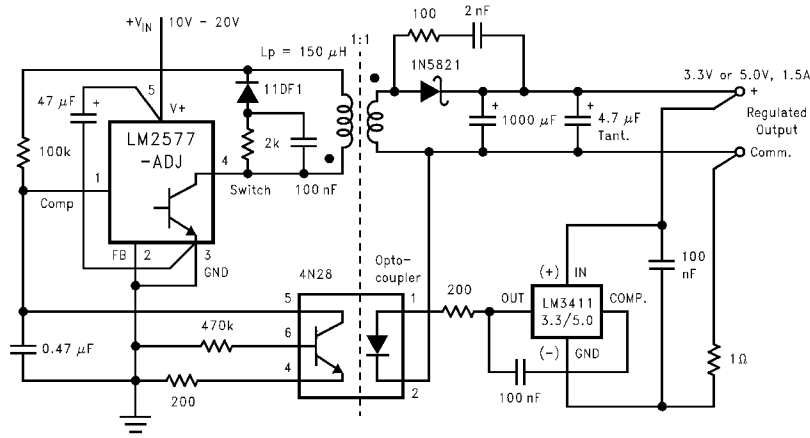

FIGURE 3. Isolated 250 mA Flyback Switching Regulator

Applications Information (Continued)



DS011987-16

FIGURE 4. Isolated 1.5A Flyback Switching Regulator Using a LM2577

The LM3411 regulator/driver provides the reference and feedback drive functions in a regulated power supply. It can also be used together with many different types of regulators, (both linear and switching) as well as other power semiconductor devices to add precision and improve regulation specifications. Output voltage tolerances better than 0.5% are possible without using trim pots or precision resistors.

One of the main applications of the LM3411 is to drive an opto-isolator to provide feedback signal isolation in a switching regulator circuit. For low current applications, (up to 250 mA) the circuit shown in *Figure 3* provides good regulation and complete input/output electrical isolation.

For an input voltage of 15V, this circuit can provide an output of either 3.3V or 5V with a load current up to 250 mA with excellent regulation characteristics. With the part values shown, this circuit operates at 80 kHz., and can be synchronized to a clock or an additional LM3578. (See LM1578 data sheet for additional information.)

An isolated DC/DC flyback converter capable of higher output current is shown in *Figure 4*. This circuit utilizes the

LM2577 SIMPLE SWITCHER™ voltage regulator for the Pulse Width Modulation (PWM), power switch and protection functions, while the LM3411 provides the voltage reference, gain and opto coupler drive functions. In this circuit, the reference and error amplifier in the LM2577 are not used (note that the feedback pin is grounded). The gain is provided by the LM3411. Since the voltage reference is located on the secondary side of the transformer, this circuit provides very good regulation specifications.

The output of a switching regulator typically will contain a small ripple voltage at the switching frequency and may also contain voltage transients. These transient voltage spikes can be sensed by the LM3411 and could give an incorrect regulation voltage. An RC filter consisting of a 1Ω resistor and a 100 nF capacitor will filter these transients and minimize this problem. The 1Ω resistor should be located on the ground side of the LM3411, and the capacitor should be physically located near the package.

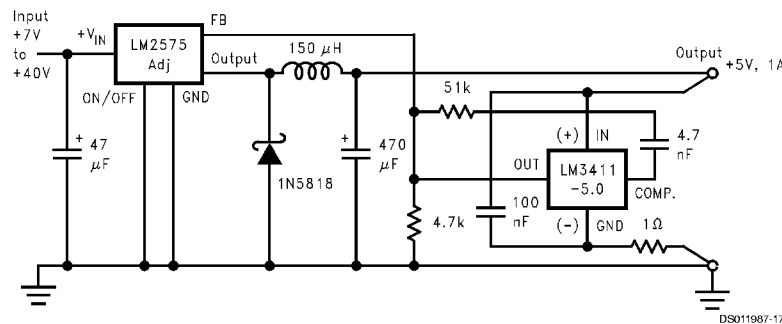

DS011987-17

FIGURE 5. Precision 1A Buck Regulator

Applications Information (Continued)

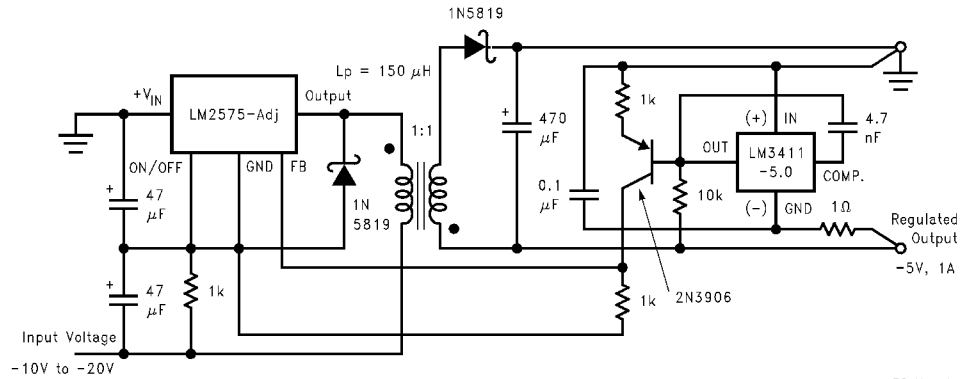

FIGURE 6. Negative Input, Negative or Positive Output Flyback Regulator

Improved output voltage tolerance and regulation specifications are possible by combining the LM3411A with one of the SIMPLE SWITCHER buck regulator IC's, such as the LM2574, LM2575, or LM2576. The circuit shown in *Figure 5* can provide a 5V, $\pm 0.5\%$ Output (1% over the operating temperature range) without using any trim-pots or precision resistors. Typical line regulation numbers are a 1 mV change on the output for a 8V–18V change on the input, and load regulation of 1 mV with a load change from 100 mA–1A.

A DC-DC flyback converter that accepts a negative input voltage, and delivers either a positive or negative output is shown in *Figure 6*. The circuit utilizes a buck regulator (such as the LM2574, LM2575, or LM2576, depending on how much output current is needed) operating in a flyback configuration. The LM3411 provides the reference and the required level shifting circuitry needed to make the circuit work correctly.

A unique feature of this circuit is the ability to ground either the high or low side of the output, thus generating either a negative or a positive output voltage. Although no isolation is

provided, with the addition of an opto-isolator and related components, this circuit could provide input/output isolation. Combining a LM3411A-5.0 with a 1A low dropout linear regulator results in a 5V $\pm 0.5\%$ (1% over the operating temperature range) regulator with excellent regulation specifications, with no trimming or 1% resistors needed.

An added benefit of this circuit (and also true of many of the other circuits shown here) is the high-side and low-side remote output voltage sensing feature. Sensing the output voltage at the load eliminates the voltage drops associated with wire resistance, thus providing near perfect load regulation.

A 5V, 1A regulator circuit featuring low dropout, very good regulation specifications, self protection features and allows output voltage sensing is shown in *Figure 7*. The regulator used is a LM2941 adjustable low dropout positive regulator, which also features an ON/OFF pin to provide a shutdown feature.

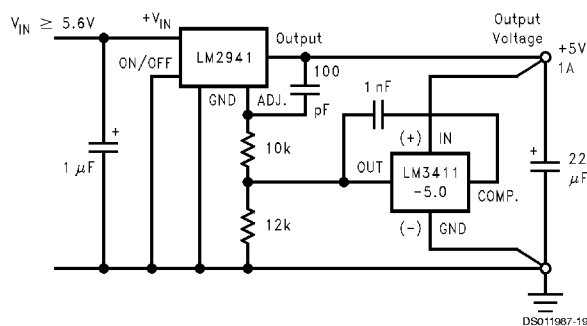

FIGURE 7. Precision 5V 1A Low Dropout Regulator

Applications Information (Continued)

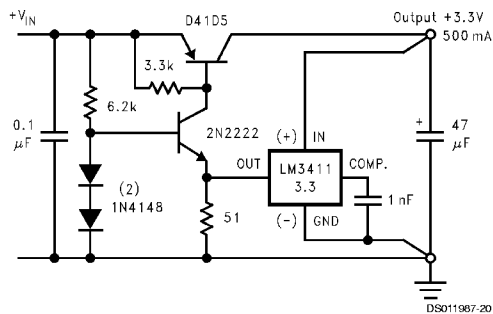

FIGURE 8. 3.3V 0.5A Low Dropout Regulator

The circuit in *Figure 8* shows a 3.3V low dropout regulator using the LM3411-3.3 and several discrete components.

This circuit is capable of excellent performance with both the dropout voltage and the ground pin current specifications improved over the LM2941/LM3411 circuit.

The standard LM317 three terminal adjustable regulator circuit can greatly benefit by adding a LM3411. Performance is increased and features are added. The circuit shown in *Figure 9* provides much improved line and load regulation, lower temperature drift, and full remote output voltage sensing on both the high and low side. In addition, a precise current limit or constant current feature is simple to add.

Current limit protection in most IC regulators is mainly to protect the IC from gross over-current conditions which could otherwise fuse bonding wires or blow IC metalization, therefore not much precision is needed for the actual current limit values. Current limit tolerances can sometimes vary from $\pm 10\%$ to as high as $+300\%$ over manufacturing and temperature variations. Often critical circuitry requires a much tighter control over the amount of current the power supply can deliver. For example, a power supply may be needed that can deliver 100% of its design current, but can still limit the maximum current to 110% to protect critical circuitry from high current fault conditions.

The circuit in *Figure 9* can provide a current limit accuracy that is better than $\pm 4\%$, over all possible variations, in addition to having excellent line, load and temperature specifications.

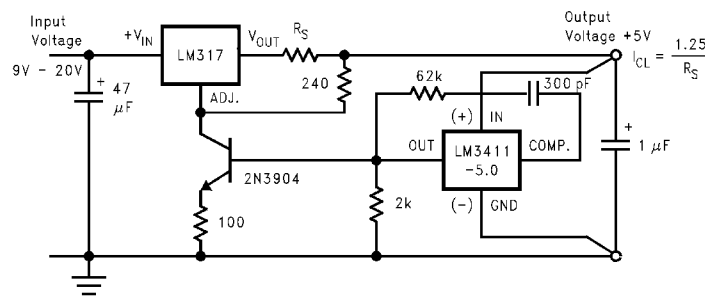

FIGURE 9. Precision Positive Voltage Regulator with Accurate Current Limit

Like the positive regulators, the performance of negative adjustable regulators can also be improved by adding the LM3411. Output voltages of either 3.3V or 5V at currents up to 1.5A (3A when using a LM333) are possible. Adding two resistors to the circuit in *Figure 10* adds the precision current limit feature as shown in *Figure 11*. Current limit tolerances of $\pm 4\%$ over manufacturing and temperature variations are possible with this circuit.

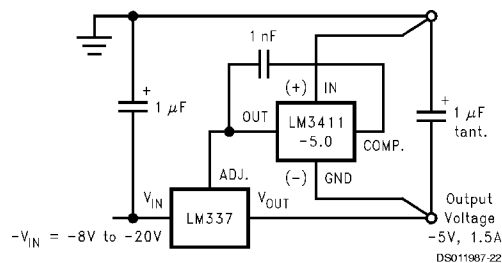

FIGURE 10. Precision Negative Voltage Regulator

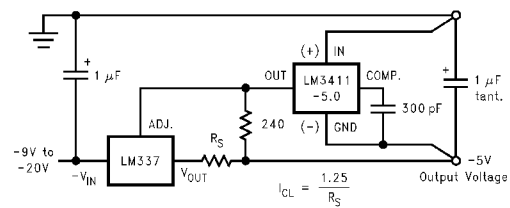
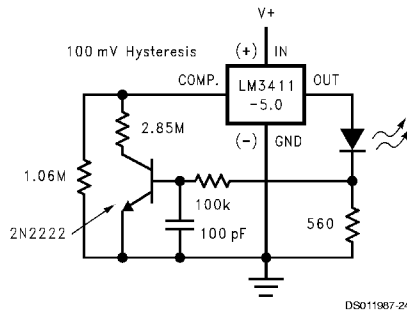

FIGURE 11. Precision Negative Voltage Regulator with Accurate Current Limit

A simple 5V supply monitor circuit is shown in *Figure 12*. Using the LM3411's voltage reference, op-amp (as a comparator) and output driver, this circuit provides a LED indication of the presence of the 5V supply.

Applications Information (Continued)



DS011987-24

FIGURE 12. 4.7V Power ON Detector with Hysteresis

The LM3411 initial room temperature tolerance is $\pm 1\%$ and $\pm 0.5\%$ for the "A" grade part. If a tighter tolerance is needed, a trim scheme is shown in *Figure 13* that provides approximately $\pm 1\%$ adjustment range of the regulation voltage (V_{REG}).

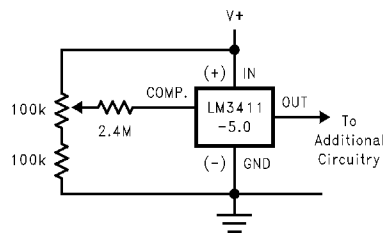

DS011987-25

FIGURE 13. ± 50 mV External Trim

The LM3411 is guaranteed to drive a 15 mA load, but if more current is needed, a NPN boost transistor can be added. The circuit shown in *Figure 14* is a shunt regulator capable of providing excellent regulation over a very wide range of current.

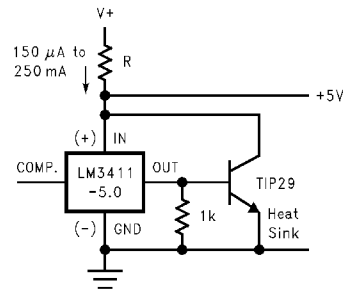

DS011987-26

FIGURE 14. 250 mA Shunt Regulator

Perhaps one of the simplest applications for the LM3411 is the voltage detector circuit shown in *Figure 15*. The OUT pin is low when the input voltage is less than V_{REG} . When the $V(IN)$ pin rises above V_{REG} , the OUT pin is pulled high by the internal NPN output resistor.

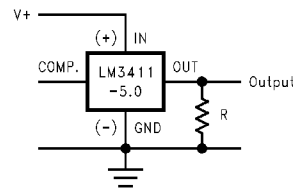

DS011987-27

FIGURE 15. Voltage Detector

Also an overvoltage detector, the crowbar circuit shown in *Figure 16* is normally located at the output of a power supply to protect the load from an overvoltage condition should the power supply fail with an input/output short.

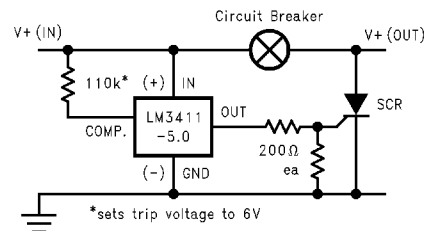

DS011987-28

FIGURE 16. Overvoltage Crowbar

Schematic Diagram

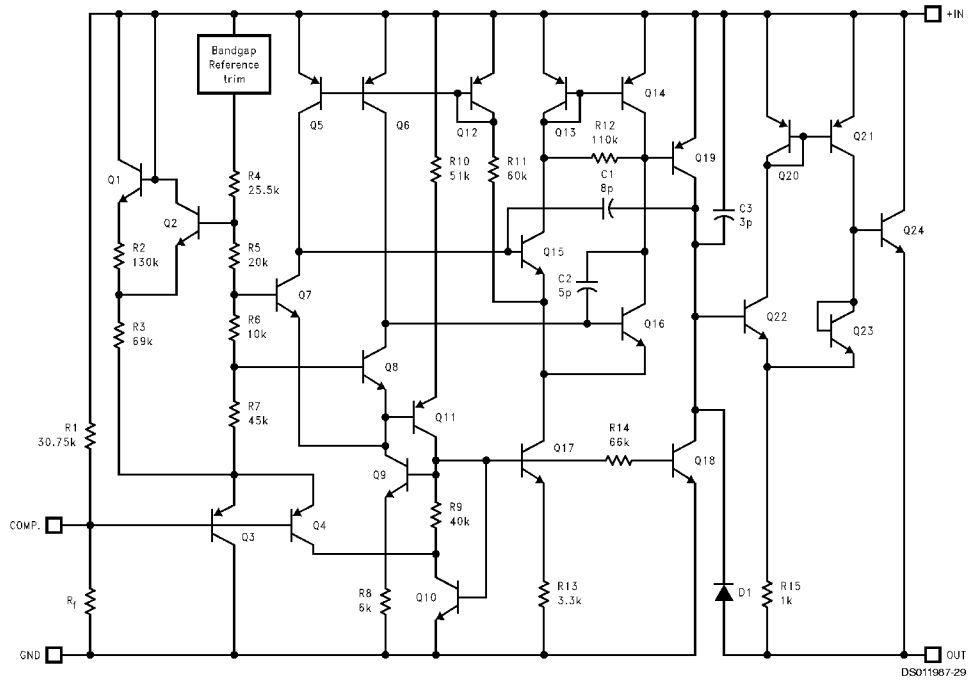

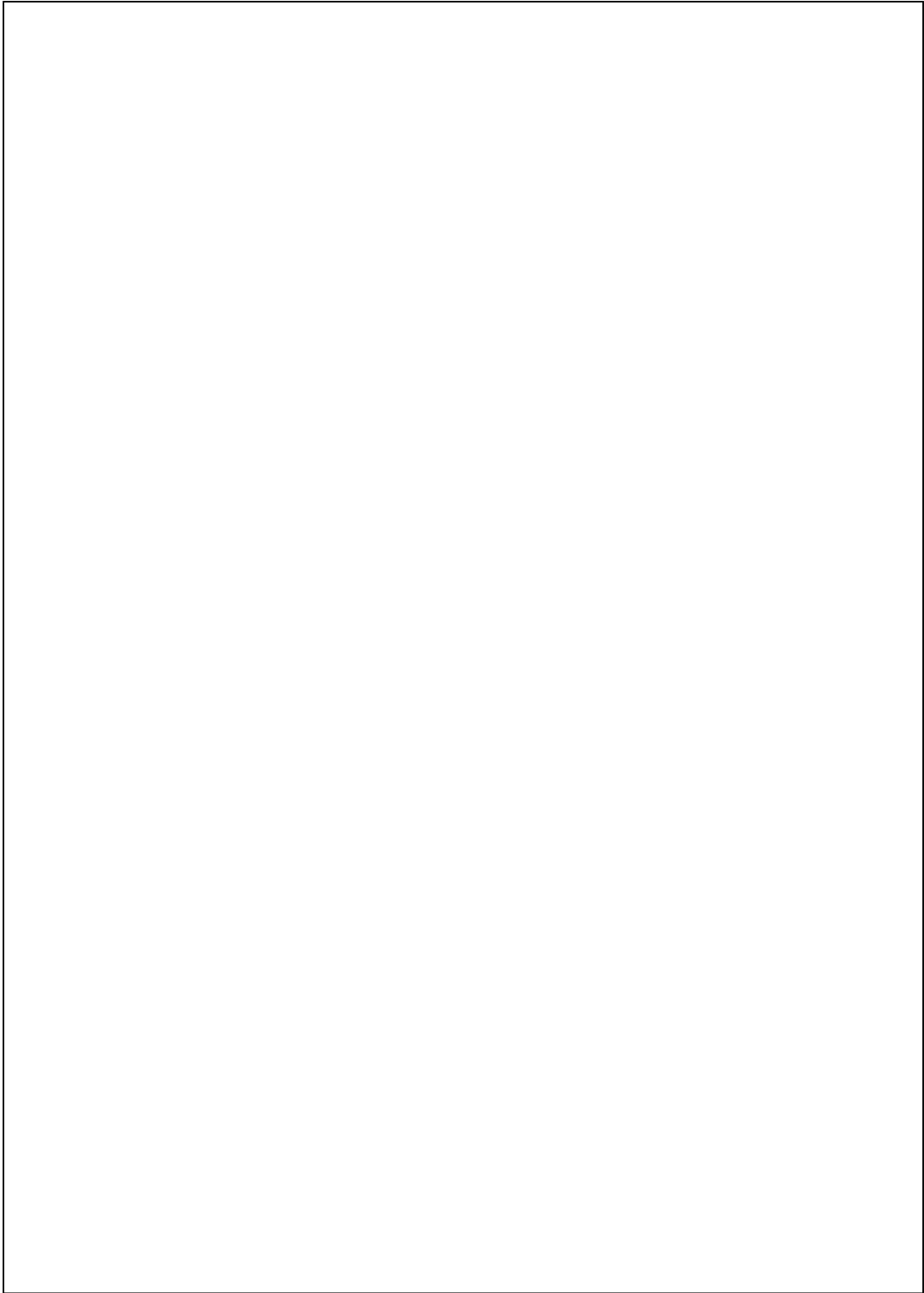

Physical Dimensions inches (millimeters) unless otherwise noted

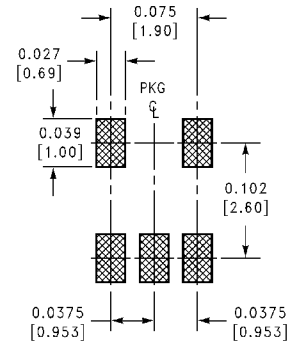
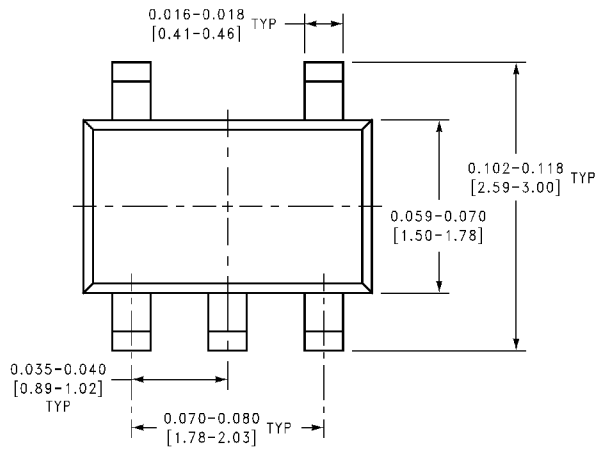

LAND PATTERN RECOMMENDATION

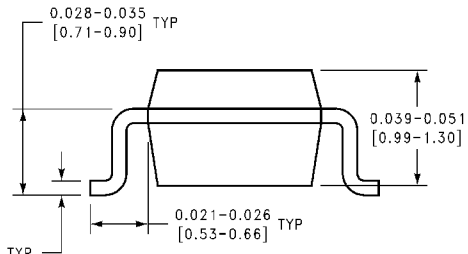
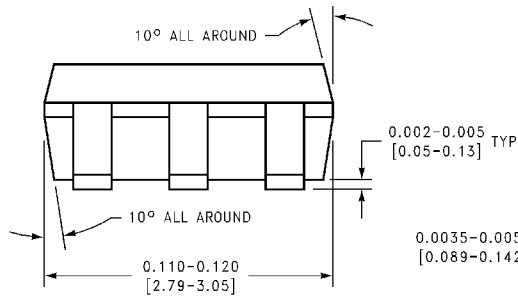

MA05A (REV D)

5-Lead Small Outline Package (M5)
Order Number LM3411M5-3.3, LM3411AM5-3.3,
LM3411M5-5.0 or LM3411AM5-5.0
NS Package Number MA05A

Physical Dimensions inches (millimeters) unless otherwise noted (Continued)

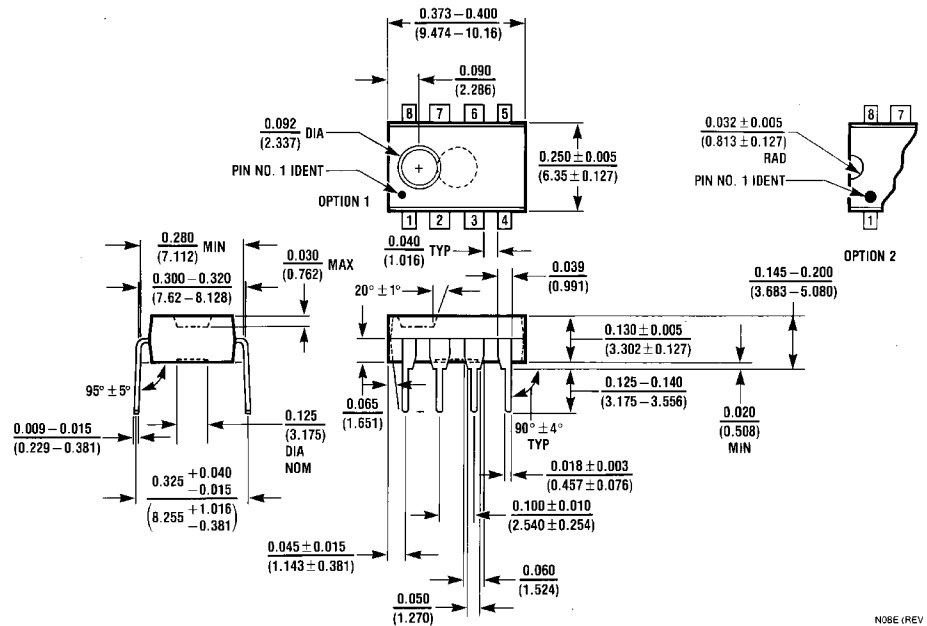

8-Lead Dual-In-Line Package (N)
Order Number LM3411N-3.3, LM3411AN-3.3,
L3411N-5.0 or LM3411AN-5.0
NS Package Number N08E

N08E (REV F)

LIFE SUPPORT POLICY

NATIONAL'S PRODUCTS ARE NOT AUTHORIZED FOR USE AS CRITICAL COMPONENTS IN LIFE SUPPORT DEVICES OR SYSTEMS WITHOUT THE EXPRESS WRITTEN APPROVAL OF THE PRESIDENT OF NATIONAL SEMICONDUCTOR CORPORATION. As used herein:

1. Life support devices or systems are devices or systems which, (a) are intended for surgical implant into the body, or (b) support or sustain life, and whose failure to perform when properly used in accordance with instructions for use provided in the labeling, can be reasonably expected to result in a significant injury to the user.
2. A critical component in any component of a life support device or system whose failure to perform can be reasonably expected to cause the failure of the life support device or system, or to affect its safety or effectiveness.



National Semiconductor Corporation
 Americas
 Tel: 1-800-272-9959
 Fax: 1-800-737-7018
 Email: support@nsc.com

National Semiconductor Europe
 Fax: +49 (0) 1 80-530 85 86
 Email: europe.support@nsc.com
 Deutsch Tel: +49 (0) 1 80-530 85 85
 English Tel: +49 (0) 1 80-532 78 32
 Français Tel: +49 (0) 1 80-532 93 58
 Italiano Tel: +49 (0) 1 80-534 16 80

National Semiconductor Asia Pacific Customer Response Group
 Tel: 65-2544466
 Fax: 65-2504466
 Email: sea.support@nsc.com

National Semiconductor Japan Ltd.
 Tel: 81-3-5620-6175
 Fax: 81-3-5620-6179

www.national.com