

REV.	DATE	DESCRIPTION
A	02/24/03	UPDATE DRAWING FORMAT
B	06/30/07	REVISE BODY LENGTH, CONTACT PIN, FERRULE DIMENSIONS

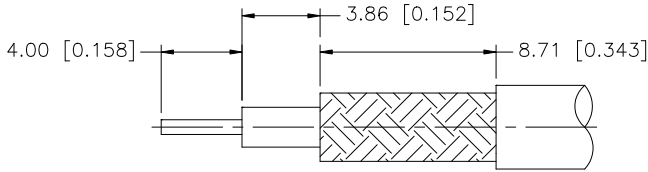

RECOMMENDED
CABLE STRIPPING DIMS.

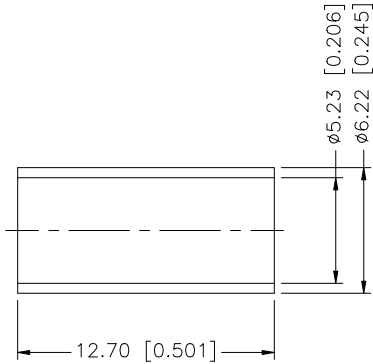
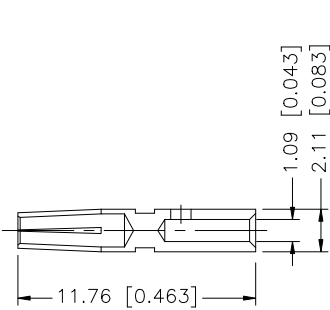
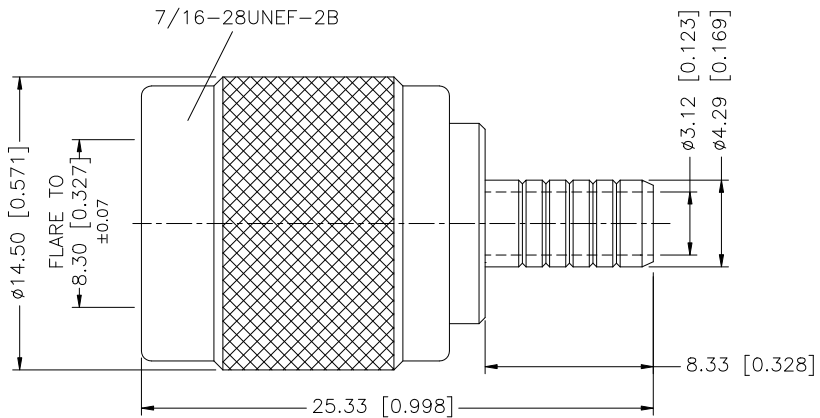

NOTE:

1. CRIMPED FERRULE HEX CRIMP SIZE .213"
2. CRIMPED CONTACT PIN HEX CRIMP SIZE .068"

				UNLESS OTHERWISE SPECIFIED DIMENSIONS ARE IN MILLIMETERS. DIMENSIONS IN [] ARE IN INCHES AND FOR CUSTOMER REFERENCE ONLY.	APPROVALS	DATE	<h1 style="color: blue; margin: 0;">Amphenol Connex</h1>					
8					DRAWN	G.R.S.					06/30/07	PART DESCRIPTION TNC REVERSE POLARITY CRIMP PLUG (FOR RG-58C/U CABLE)
7					CHECKED			PART NO. 122108RP				
6					ISSUED							DWG. NO. 122108RP.DWG
5	FERRULE	COPPER	NICKEL	1	SHEET	1 OF 1		REV. B SIZE A SCALE NA				
4	GASKET	RUBBER	RED	1								CAD FILE C:/122/122108RP.DWG
3	CONTACT PIN	PHOS. BRONZE	GOLD	1	UNLESS OTHERWISE SPECIFIED TOLERANCES FOR MILLIMETERS ARE: 0.5 - 8mm ± 0.20mm 8 - 30mm ± 0.40mm 30 - 120mm ± 0.50mm UNLESS OTHERWISE SPECIFIED TOLERANCES FOR INCHES ARE: .020 - .315 = ± 0.007" .315 - 1.180 = ± 0.015" 1.180 - 4.724 = ± 0.020" DO NOT SCALE DRAWING				DESCRIPTION MATERIAL FINISH QTY			
2	INSULATOR	TEFLON	NATURAL	1								
1	SHELL/BODY	BRASS	NICKEL	1	DESCRIPTION MATERIAL FINISH QTY							