

THIS DRAWING IS UNPUBLISHED. RELEASED FOR PUBLICATION .19
 © COPYRIGHT 19 BY AMP INCORPORATED, HARRISBURG, PA. ALL INTERNATIONAL RIGHTS RESERVED. AMP PRODUCTS MAY BE COVERED BY U.S. AND FOREIGN PATENTS AND/OR PATENTS PENDING.

LOC	DIST	P	F	ZONE	LTR	DESCRIPTION	DATE	APPROVED
AF	50				H	ADDED -2 PER 0L10-0466-97	11/19/97	

1 - CONTINUOUS STRIP ON REELS.
 2 - REVERSE REELING OF 63497-1.

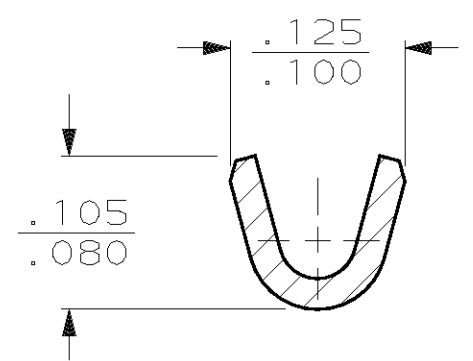
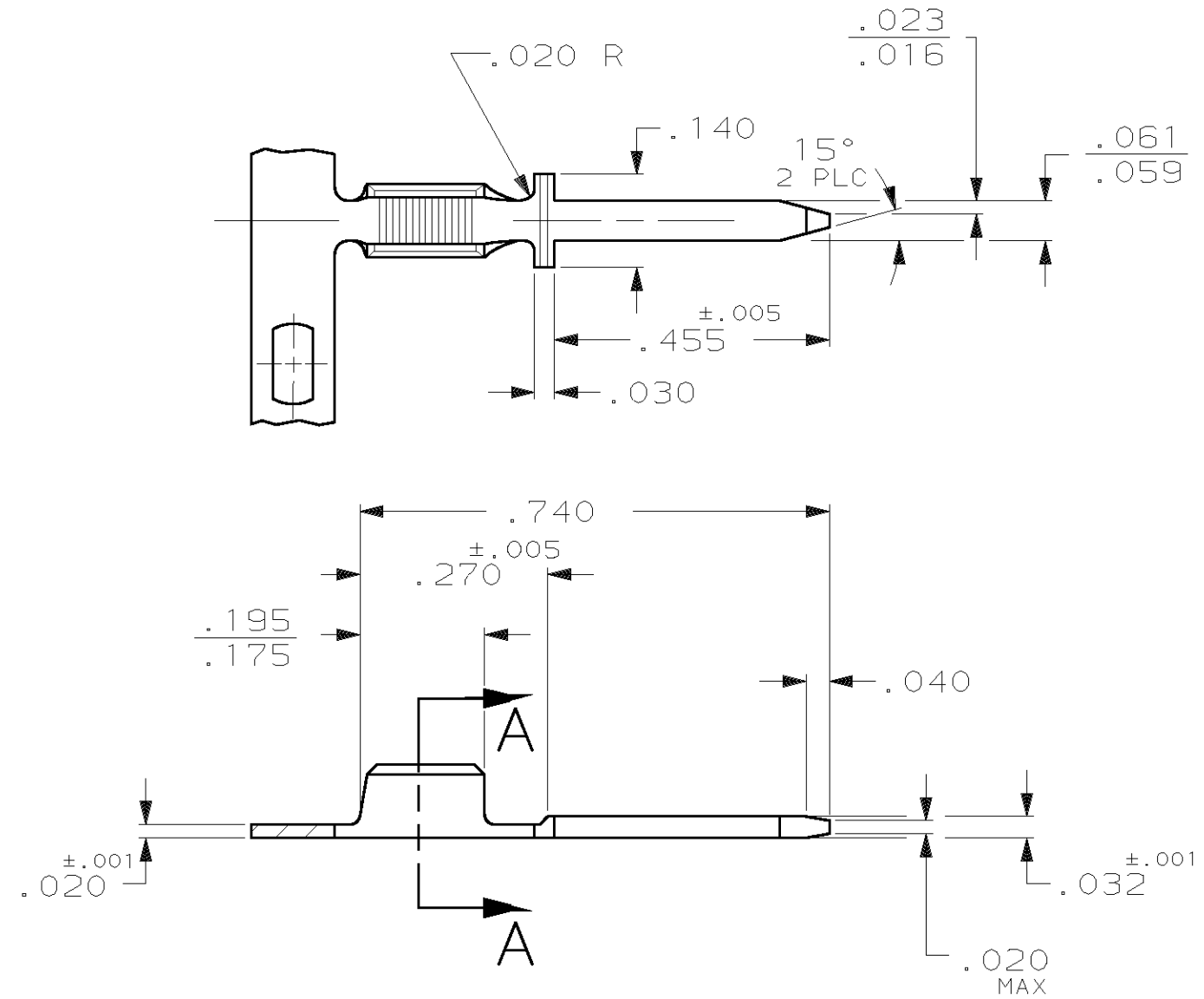

2	23-19 MAGNET	63497-2
	23-19 MAGNET	63497-1
	WIRE BARREL	PART NO

UNLESS OTHERWISE SPECIFIED DIMENSIONS ARE IN INCHES TOLERANCES ON: 2 PL DEC ± _____ 3 PL DEC ± .010 ANGLES ± _____		DR 5/27/88 JR RUTH	AMP INCORPORATED Harrisburg, Pa. 17105	
MATERIAL #2H PREMILLED BRASS		CHK 5/27/88 MS FEHER		
FINISH TIN .000080 MIN		APPD 5/27/88 C MEYERS	NAME TAB, AMPLIVAR	
		APPD 5/27/88 R KUZO	SIZE B	FSCM NO 00779
		PRODUCT SPEC _____	DRAWING NO 63497	
		APPLICATION SPEC _____	SCALE 4:1	SHEET 1 OF 1
		WEIGHT _____		