

# HMS-EN2PB-R Linking Device INSTALLATION SHEET



HMS Industrial Networks AB  
Web: [www.anybus.com](http://www.anybus.com)  
Tel: +46 35 172900  
E-mail: [info@hms.se](mailto:info@hms.se)



SP2092, rev 1.00, March 2017.

[www.anybus.com](http://www.anybus.com)

## Module Front

USB port:  
Connect a PC to the USB port for firmware upgrades.

EtherNet/IP Connector:

Pin no	Description
1	TX+
2	TX-
3	RX+
6	RX-
4, 5, 7, 8	Termination

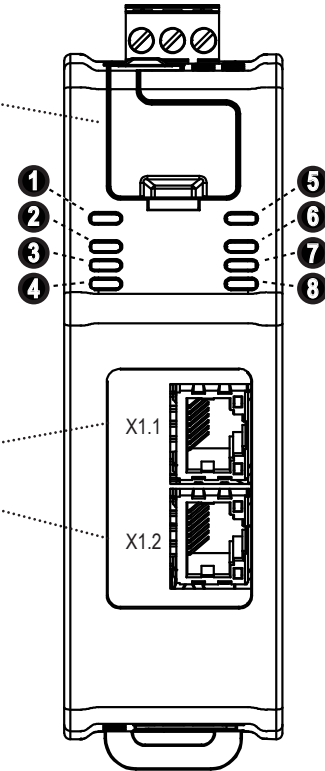
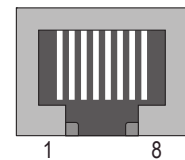

## LED Indicators:

No	Name	Indication	Meaning
1	(MS EN) Module Status	Off Flashing green Green Yellow Flashing red Red	Power off Not configured, or scanner in idle state Controlled by a scanner in run state Boot up Recoverable error Fatal error
2	(NS) Network Status	Off Flashing green Green Yellow Flashing red Red	No IP address Online, no connection Online, connection established Boot up Timeout Duplicate IP address, fatal error
3	(Link 1, Link 2) Ethernet Link 1 & 2	Off Flashing green Yellow Flashing yellow	No link Receiving/transmitting Ethernet packets at 100 Mbit Boot up Receiving/transmitting Ethernet packets at 10 Mbit
5	(MS PB) Master Status	Off Red Flashing green Green	Master is offline Master in STOP mode Master in CLEAR mode Master in OPERATE mode
6	(DB) Database Status	Off Green Flashing green Red	No database Database OK Database download in progress Database invalid
7	(CS) Communication Status	Off Green Flashing green Red	No data exchange Data exchange with all slaves Data exchange with at least one slave Bus control error
8	(TH) Token Hold	Off Green	Another station holds the Token Master interface holds the Token

At power-up, LED 1 - 4 will indicate solid yellow for 15 - 30 seconds. This will be followed by a LED test sequence, performed on the (MS EN) Module Status and (NS) Network Status LEDs.

## Accessories Checklist

The following items are required for installation:

- Subnetwork connector.
- Ethernet cable and connector (not included).

## Installation and Startup Summary

- Mount the EN2PB-R linking device on the DIN-rail.
- Connect the linking device to the EtherNet/IP network.
- Connect the device to the PROFIBUS network.
- Connect the power cable and apply power.
- Assign an IP address to the device using a BOOTP-DHCP server.
- Start the Studio 5000 software.
- Search in the catalogue for the HMS-EN2PB-R.
- Add the device to the Ethernet network in the I/O configuration.
- In the general tab, assign a name and the previously chosen IP address to the device.
- Configure the device using the configuration manager and download the configuration to the device.
- Set up the EtherNet/IP communication according to the device configuration.

## Technical Details

- Power supply:  
24 V DC (-15% to +20%).
- Power consumption:  
Maximum power consumption is 300 mA @ 24 V DC.  
Typical power consumption: 220 mA @ 24 V DC.
- Functional Earth (FE):  
Internal connection to FE via DIN-rail or, if the DIN-rail can not be used, via the power connector.  
**Note:** Make sure the DIN-rail is properly connected to FE.

## Top View

Power:  
(+) +24 V DC  
(-) GND  
(⊕) FE

SD card slot:  
(Not used)

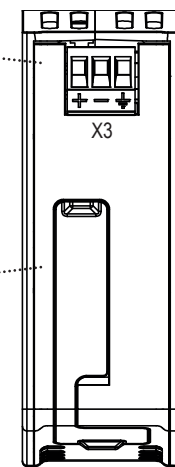

## PROFIBUS Bottom Connector (DB9F)

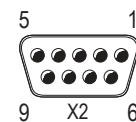

Pin no	Description
3	B-Line
4	RTS
5	GND bus
6	+5 V bus out
8	A-Line
1, 2, 7, 9	Not connected
Housing	FE

For maintenance and support, contact the HMS support department. Contact information is available at the support pages on [www.anybus.com](http://www.anybus.com).

Further information and documents about this product can be found at the product pages on [www.anybus.com](http://www.anybus.com).

# HMS-EN2PB-R Linking Device INSTALLATION SHEET

## DIN-rail Mounting

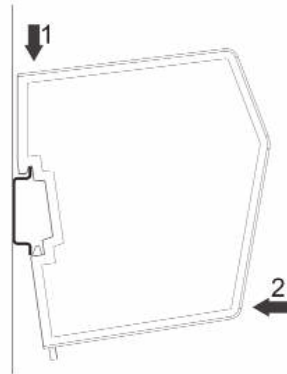

Ensure that the DIN-rail fastening mechanism on the back of the module is in a fixed and closed position, i. e. that it is pushed all the way up.

To mount the module, first hook it on to the DIN-rail (1), then push it against the DIN-rail to make it snap on (2).

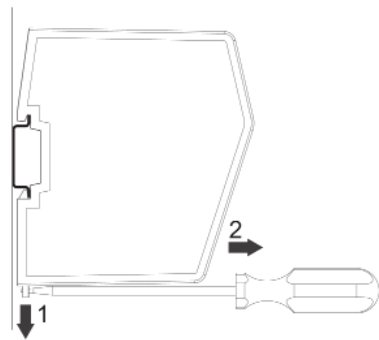

To unmount the module, use a screwdriver to push the DIN-rail fastening mechanism on the back of the module down until it locks in a fixed and open position (1). Then unhook the module from the DIN-rail (2).

**Note:** Do not leave the module with the DIN-rail fastening mechanism in a fixed and open position. This may cause unnecessary wear on the fastening mechanism, so that it cannot be used efficiently. Be sure to push the DIN-rail fastening mechanism back into the fixed and closed position after unmounting the module, with reference to the picture below.

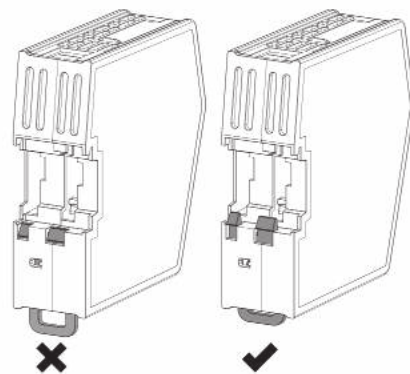

## Additional Installation and Operating Instructions

Supply voltage: The linking device requires a regulated 24 (20.4-28.8V) VDC power source.

Field wiring terminal markings (wire type Cu only, 14-30AWG)  
"Use 105°C copper (Cu) wire only"  
Terminal tightening torque (5-7 lb-in).

Use in Overvoltage Category I Pollution Degree 2 Environment.

Install in an enclosure considered representative of the intended use. To comply with ATEX directives, the equipment must be installed within an IP54 enclosure and must be installed with a transient suppressor on the supply that does not exceed 140% (33.6 V DC) of the nominal rated supply voltage.

Operating temperature/Surrounding temperature:  
-25° to +60° degrees C @ 300 mA @ 24 V DC.  
**NOTE:** If the surrounding temperature exceeds +40° C, install the unit with at least 10 mm of air on each side.

Maximum surface temperature: 135 degrees C.

Pressure: 850 - 1050 millibar.

This product is designed to safely operate in class I, division 2 Hazardous location according to ANSI/ISA 12.12.01-2015 and category 3, zone 2 according to EN 60079-0 and EN 60079-15.

SUITABLE FOR USE IN CLASS I, DIVISION 2, GROUPS A, B, C AND D HAZARDOUS LOCATIONS, OR NONHAZARDOUS LOCATIONS ONLY.

## Warnings

- **WARNING - EXPLOSION HAZARD - SUBSTITUTION OF ANY COMPONENTS MAY IMPAIR SUITABILITY FOR CLASS I, DIVISION 2.**
- **WARNING - EXPLOSION HAZARD - WHEN IN HAZARDOUS LOCATIONS, TURN OFF POWER BEFORE REPLACING OR WIRING MODULES.**
- **WARNING - EXPLOSION HAZARD - DO NOT DISCONNECT EQUIPMENT WHILE THE CIRCUIT IS LIVE OR UNLESS THE AREA IS KNOWN TO BE FREE OF IGNITABLE CONCENTRATIONS.**
- **WARNING - EXPLOSION HAZARD- THE USB CONNECTOR IS NOT FOR USE IN HAZARDOUS LOCATIONS AND FOR TEMPORARY CONNECTION ONLY. DO NOT USE, CONNECT OR DISCONNECT UNLESS THE AREA IS KNOWN TO BE NONHAZARDOUS. CONNECTION OR DISCONNECTION IN AN EXPLOSIVE ATMOSPHERE COULD RESULT IN AN EXPLOSION.**
- **WARNING - EXPLOSION HAZARD - DO NOT CONNECT OR DISCONNECT THE SD CARD UNLESS THE AREA IS KNOWN TO BE NONHAZARDOUS. CONNECTION OR DISCONNECTION IN AN EXPLOSIVE ATMOSPHERE COULD RESULT IN AN EXPLOSION.**
- **WARNING - INSTALL IN AN ENCLOSURE CONSIDERED REPRESENTATIVE OF THE INTENDED USE. TO COMPLY WITH ATEX DIRECTIVES, THE EQUIPMENT MUST BE INSTALLED WITHIN AN IP54 ENCLOSURE AND MUST BE INSTALLED WITH A TRANSIENT SUPPRESSOR ON THE SUPPLY THAT DOES NOT EXCEED 140% (33.6 V DC) OF THE NOMINAL RATED SUPPLY VOLTAGE.**

## UL Certification



Ind. Contr. Eq./Haz.Loc.  
22ZB, E214107  
67AM, E203225  
CL1, DIV 2, GP A, B, C, D  
TEMP CODE T4

## Atex Certification

EX nA IIC T4 Gc



Demko 16 ATEX 1775X

## EMC Compliance (CE)



This product is in accordance with the EMC directive 2014/30/EU through conformance with the following standards:

- **EN 61000-6-4**  
Emission standard for industrial environment  
EN 55016-2-3, Class A
- **EN 61000-6-2**  
Immunity for industrial environment  
EN 61000-4-2  
EN 61000-4-3  
EN 61000-4-4  
EN 61000-4-5  
EN 61000-4-6

HMS Industrial Networks AB  
Stationsgatan 37  
302 45 Halmstad  
Sweden



Further information and documents about this product can be found at the product pages on [www.anybus.com](http://www.anybus.com).