



Please note that Cypress is an Infineon Technologies Company.

The document following this cover page is marked as “Cypress” document as this is the company that originally developed the product. Please note that Infineon will continue to offer the product to new and existing customers as part of the Infineon product portfolio.

Continuity of document content

The fact that Infineon offers the following product as part of the Infineon product portfolio does not lead to any changes to this document. Future revisions will occur when appropriate, and any changes will be set out on the document history page.

Continuity of ordering part numbers

Infineon continues to support existing part numbers. Please continue to use the ordering part numbers listed in the datasheet for ordering.

General Description

CY9EF226 series is based on Cypress's advanced Arm® architecture (32-bit with instruction pipeline for RISC-like performance). Improvements compared to the previous generation include significantly improved performance at higher frequency, reduced power consumption and faster start-up time.

For highest processing speed at optimized power consumption an internal PLL can be selected to supply the CPU with up to 128 MHz operation frequency from an external resonator.

Note: Arm, Cortex, Thumb and CoreSight are the trademarks of Arm Limited in the EU and other countries.

Features

High-Performance/High Memory Content

- Arm® Cortex®-R4, 8KB D-Cache, 8KB I-Cache
- 32-Bit Armv7 architecture
- 205 DMIPS
- 2MB Internal Flash
- 48KB Internal EFlash (Data Flash)
- 208KB Internal RAM with ECC

Graphics

- 2D-Graphics Engine
- 1MB Embedded VRAM
- Max Resolution: 1024 pixel hor. x 1024 pixel ver.
- 4 Display Layer plus Alpha blending layer
- Display Controller/TCON
- Max. Pixel clock of 40MHz
- Bit Blitter
- Signature Unit
- Command Sequencer
- TTL and RSDS Output (RGB888)
- Dithering for Display with low color resolution

Connectivity

- 2x CAN, 2 x LIN-USART, 3 x SPI, 1 x I2C, 2 x I2S
- Up to six Stepper Motor Control (SMC) outputs
- HS-SPI (memory mapped access)

Safety Features/Security Features

- Multiple Memory Protection Units (MPU)
- Peripheral Protection Units (PPU)
- Timing Protection Unit (TPU)
- Cyclic Redundancy Checks (CRC of Flash, Cache and RAM)
- Watchdog
- Flash-, Debug- and Test-Security

- Secure Hardware Extension (SHE)
 - Self-contained secure area
 - Random Number generator
 - Secure repository for cryptographic keys
 - AES encryption/decryption block

Other Features

- Up/Down Counters
- Programmable Pulse Generators
- Analog-to-Digital Converters - 50 channels
- Sound Generator
- Free Running/Reload Timers
- Real Time Clock (RTC)
- Input Capture Units, Output Compare units
- 32 external Interrupts

Low Power

- Switchable Power Domains
- 16KB Retention RAM
- Flexible Clock Control
- Debugging/Testing
- Arm® Coresight™ Debug and Trace
- Debugging via JTAG Interface
- Boundary Scan

Characteristics

- 5V and 3.3V capable IOs
- Ta: -40 °C to +105 °C
- Package: LQFP-176

Applications

- Hybrid Automotive Instruments Cluster with pointers and TFT display
- Classical Automotive Instruments Cluster with pointers

Errata: For information on silicon errata, see [Errata on page 292](#). Details include trigger conditions, devices affected, and proposed workaround.

Block Diagram

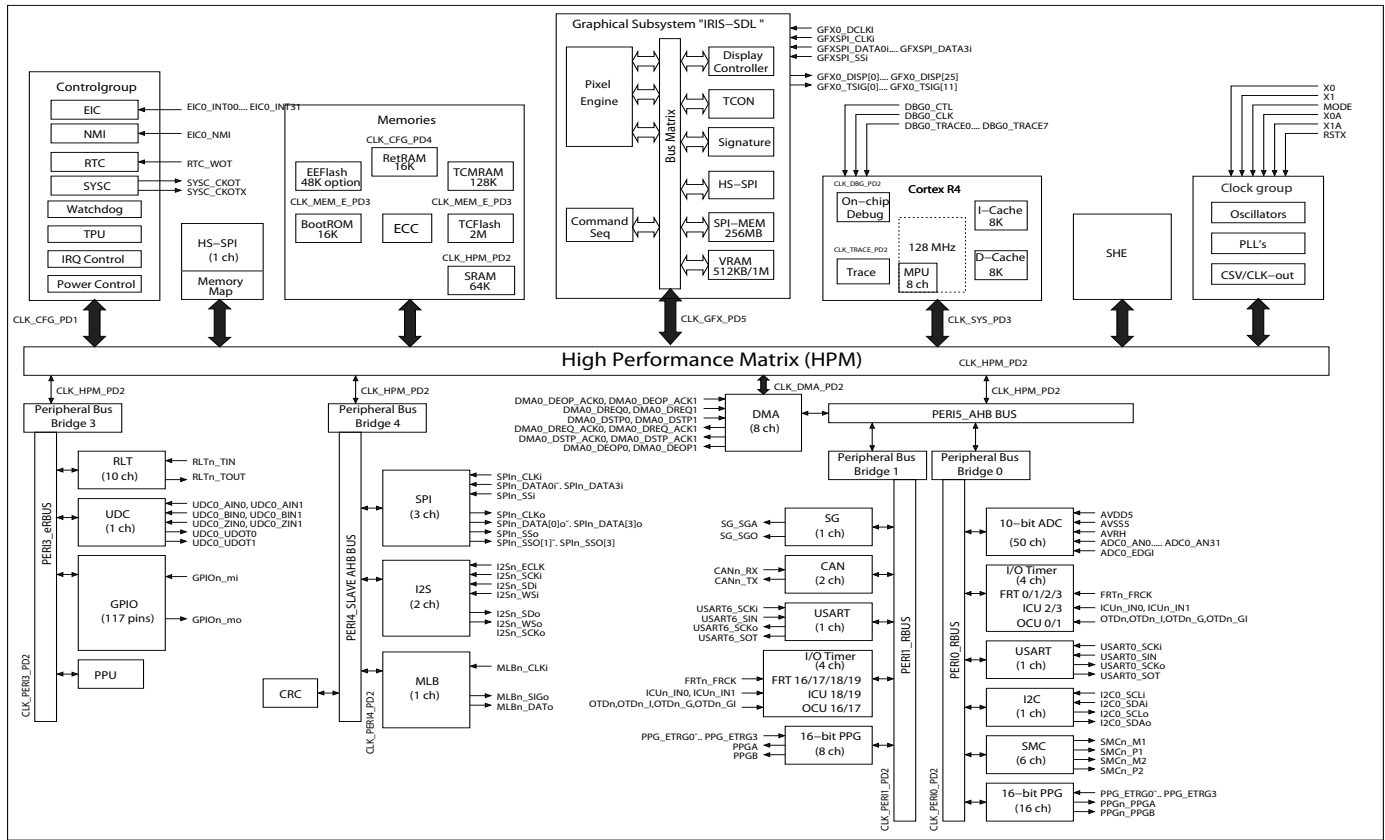

Power Domain

Power Domain	Modules
PD1	Clockgroup (Osc, PLL, CSV), Controlgroup (EIC, NMI, RTC, SYSC, WDG, TPU, IRQ Control, Power Control)
PD2	Peripheral bus 0 (ADC, FRT, ICU, OCU, USART, I2C, SMC, PPG), Peripheral bus 1 (SG, CAN, USART, FRT, ICU, OCU, PPG), Peripheral bus 3 (RLT, UDC, GPIO, PPU), Peripheral bus 4 (SPI, I2S), On-Chip Debug, Trace, SRAM, CRC, Cortex R4, SHE, MPU, I-Cache, D-Cache, TCM, TCFflash, EEFflash, TPU, BootROM, HS-SPI, MLB, IRIS-SDL
PD4	RetRAM

Contents

CY9EF226 Features	4	Boundary Scan	275
Resource Distribution for Non-modulated Clock	13	Flash Parallel Programming	277
Lock/Unlock Values for Protection Units	13	Debug and Trace	286
ID-Values for Module Identification Registers	14	Handling Devices	288
Package and Pin Assignment	15	Preventing Latch-up	288
Package	15	Handling of Unused Input Pins	288
QFP-176 Pin Assignment	15	Power Supply Pins	288
I/O Pins and Functions	19	Power on Sequence	288
I/O Pin Types	65	Pin State During Active External Reset	289
IO Circuit Types	68	Crystal Oscillator Circuit	289
Packages	73	Notes on Using External Clock	289
Interrupt/DMA	74	Reference Documents	291
Interrupt Table	74	Errata	292
NMI	80	Ordering Information	309
DMA Overview	81	Appendix	310
PPU	85	Workaround for Flash Erase Suspend Issue	310
Master ID	86	Workaround for IRQ Unit Register Read	
I/O Map	86	Timing Issue	311
Electrical Characteristics	245	Workaround for IUNIT Interrupt Handling	
Absolute Maximum Ratings	245	Problem	318
Recommended Operating Conditions	249	Document History Page	320
DC Characteristics	250	Sales, Solutions, and Legal Information	321
AC Characteristics	257	Worldwide Sales and Design Support	321
Analog Digital Converter	268	Products	321
FLASH Memory Program/Erase Characteristics	270	PSoC® Solutions	321
RC Oscillator Frequency	271	Cypress Developer Community	321
ESD Structure between Power Domains	273	Technical Support	321
Procedures	275		

CY9EF226 Features
Table 1. Overview

Feature	CY9EF226 / QFP-176	CY9EF226L / QFP-176
Max. Core frequency	128 MHz	128 MHz
DMA	8 channels	8 channels
TCFlash	2 MB	2 MB
EEFlash	48 KB	48 KB
AXI RAM (with ECC)	64 KB	64 KB
TCM RAM (with ECC)	128 KB	128 KB
RetRAM	16 KB	16 KB
Core has 4-way-associative cache	I/D each 8KB	I/D each 8KB
SHE	yes	yes
Boot-ROM	16 KB	16 KB
IRQ Ctrl	256	256
Graphics subsystem	Iris-SDL	-
Graphic RAM (VRAM)	1MB	1MB
RTC (with auto calibration)	1 channel	1 channel
Source clock timer	4	4
RLT (Reload Timer) (32 bit)	10 channels	10 channels
FRT	8 channels	8 channels
ICU	8 channels	8 channels
OCU	8 channels	8 channels
PPG	24 channels	24 channels
SG (Sound Generator)	1 channel	1 channel
UDC (UpDown Counter)	2 channels	2 channels
CAN	2 channels	2 channels
USART (LIN-USART)	2 channels	2 channels
SPI	3 channels	3 channels
I2C	1 channel	1 channel
I2S	2 channels	2 channels
Quad - SPI	2 channel	2 channel
Media LB	1 channel	1 channel
EIC (External Interrupts)	32 channels	32 channels
NMI (intern / extern)	32/1	32/1
SMC	4(6) channels	4 channels
ADC (10-bit)	50 channels (including 24 channels shared with SMC)	50 channels (including 24 channels shared with SMC)
CRC	1 channel	1 channel
Package	QFP-176	QFP-176

Table 2. Device Features

Feature	Description
Technology	90 nm CMOS with embedded flash
Processor Subsystem	<ul style="list-style-type: none"> ■ Cortex R4 CPU core ■ 32-bit Arm architecture, dual-issue superscalar eight stage pipeline ■ Armv7 and Thumb[®]-2 instruction set compliant ■ Memory Protection Unit (MPU) with 12 regions ■ Two Tightly Coupled Memory (TCM) ports. 64-bit AXI slave port for access to TCMs ■ 64-bit AXI master port ■ Vectored Interrupt Controller (VIC) port for faster interrupt processing ■ Single error correction, double error detection (SECCDED) Error Correction Coding (ECC) for memory error detection and correction ■ Instruction cache: 8KB 4-way set-associative ■ Data cache: 8KB 4-way set-associative ■ Up to 8 break-points and 8 watchpoints
Debug and Trace	<ul style="list-style-type: none"> ■ Arm[®] Coresight[™] technology ■ Standard 5-pin JTAG interface ■ 4-bit, 8-bit and 16-bit trace data width supported depending on package ■ Secure entry supported for debugger
Graphics Subsystem	<ul style="list-style-type: none"> ■ 2D graphics engine with base level hardware acceleration ■ Maximum frame resolution: 1024 pixel x 1024 pixel ■ Video modes up to 40MHz pixel clock ■ 1MB embedded SRAM video memory ■ 64-bit multi-layer AXI bus for memory access ■ Quad SPI interface for external flash ■ One background and 3 alpha blended foreground layers. ■ One dedicated alpha layer. ■ Rotation of display by 90/180/270 degrees ■ Gamma correction for display output ■ Color dithering for low resolution panels ■ Copy and blend bit operations (OpenGL and OpenVG blending modes) ■ Pixel formats 1, 2, 4, 8, 16, 24, and 32 bpp ■ Raster operations (ROP2 and ROP3)
Clocks	<ul style="list-style-type: none"> ■ External main clock of 4MHz (up to 8MHz under evaluation) ■ External sub clock (typical 32.768 kHz) ■ Embedded RC oscillator (typical 8/12 MHz, configurable) ■ Embedded Slow RC oscillator (typical 100 kHz) ■ On-chip Phase Locked Loop (PLL) clock multiplier for main clock, Spread Spectrum Clock Generation (SSCG), SSCG for graphics ■ Stabilization timers for all source clocks
Clock Supervisor	<ul style="list-style-type: none"> ■ Clock supervision for all source clocks and PLL outputs ■ Reset generation for out-of-bound clock frequencies on input source clocks, or PLL output clocks
Resets	<ul style="list-style-type: none"> ■ External Reset ■ Software triggered hard reset ■ Clock supervision resets ■ Watchdog ■ Low Voltage Detection reset ■ Software reset
Watchdog Timer	<ul style="list-style-type: none"> ■ 32-bit counter ■ Supports selection of four clock sources (Main clock, Sub clock, RC clock or Slow RC clock) ■ Support for window watchdog functionality ■ Reset or NMI generation support on watchdog errors ■ Support for preemptive warning interrupt before watchdog reset or NMI generation ■ Additional safety provision through three times redundancy and error correction logic for important configuration bits ■ Option to halt watchdog counter in case of core reaching break-point

Table 2. Device Features (Continued)

Feature	Description
DMA	<ul style="list-style-type: none"> ■ 64-bit AHB Master Interface ■ 32-bit AHB Slave Interface ■ Block, burst and demand transfer modes ■ Fixed and incremental addressing for source as well as destination ■ 116 clients ■ 8 channels to handle independent data flows ■ Fixed priority, dynamic priority, and round robin arbitration
Interrupts	<ul style="list-style-type: none"> ■ Interrupt Request (IRQ) and Fast Interrupt Request (FIQ) capability ■ NMI sources can generate FIQ ■ Supports 32 Non Maskable Interrupt (NMI) source for FIQ generation ■ Supports 512 Normal Interrupt sources for IRQ generation ■ Supports request for low power mode entry ■ Programmable 32-level priority controller for normal IRQ sources. Also, supports programmable priority level masking ■ Programmable 16-level priority controller for NMI interrupt sources ■ Software interrupt generation ■ Privileged mode support for restricted access
External Interrupts	<ul style="list-style-type: none"> ■ Up to 32 pins can be used as external interrupts ■ Optional 25ns (typical) noise filters on all lines ■ DMA support ■ NMI support ■ Five polarity support ('H', 'L', rising edge, falling edge, and, any edge) ■ Event capture support for all 32 external interrupt pins ■ Software enabled monitoring of external events, with sampling frequency of 500Hz to 16MHz
Timing Protection	<ul style="list-style-type: none"> ■ Up to eight identical 24-bit timers for execution time protection, locking time protection, inter-arrival time protection or deadline protection ■ Normal and overflow mode support ■ Global linear prescaler (1 to 64) to scale down clock frequency ■ Additional, individual timer prescaler to support 4 different software programmable frequencies (1, 1/2, 1/4, and 1/16) ■ Start, stop, and continue options per timer controllable by software
Memory Protection	<ul style="list-style-type: none"> ■ Memory protection unit for all bus masters ■ AXI interface support ■ 8 programmable memory regions, and one background region which covers entire 4GB address space ■ Unauthorized access generates NMI
Peripheral Protection	<ul style="list-style-type: none"> ■ Protection to all peripherals and General Purpose IOs (GPIO) ■ Individual protection setting for up to 512 peripherals, and 512 GPIO channels ■ DMA access support for faster register configuration
CAN	<ul style="list-style-type: none"> ■ Supports CAN protocol version 2.0 part A and B ■ Bit rates up to 1 Mbps ■ 64 message objects ■ Each message object has its own identifier mask ■ Programmable FIFO mode (concatenation of message objects) ■ Maskable interrupt ■ Disabled automatic retransmission mode for time triggered CAN applications ■ Programmable loop-back mode for self-test operation
USART/LIN	<ul style="list-style-type: none"> ■ Programmable LIN or USART function ■ Full-duplex support ■ Clock synchronous (start-stop synchronization and start-stop-bit option), and Clock asynchronous (using start-, stop-bits) transfer modes ■ Dedicated baud rate generator. Mechanism for automatic baud rate adjust available in LIN mode ■ Support for data length of 7-bits (not in synchronous or LIN mode) and 8-bits ■ Support for signal modes Non-Return to Zero (NRZ) and Non-Return to Zero Inverted (NRZI) ■ Reception error detection for framing, overrun, parity, checksum, sync field timeout, and frame-ID (only in LIN mode) errors ■ Interrupt capability for transmission, reception, and errors ■ DMA support

Table 2. Device Features (Continued)

Feature	Description
I2C	<ul style="list-style-type: none"> ■ Master/slave transmitting and receiving functions ■ 7-bit addressing as master and slave ■ 10-bit addressing as master and slave ■ Acknowledge disable option upon slave address reception (master-only operation) ■ Address mirroring to give interface several slave addresses ■ Up to 400 kbps transfer rate ■ Optional noise filters for SDA and SCL ■ Interrupt capability on transmission and bus error events
Stepper Motor Control	<ul style="list-style-type: none"> ■ PWM duty cycle programmable from 0% to 100% ■ Programmable setting to select 'L', 'H', 'PWM' and 'HighZ' output ■ High current output pins
A/D Converter	<ul style="list-style-type: none"> ■ 50 channels ■ Conversion time: 1us per channel ■ RC type Successive Approximation (SAR) with sample and hold circuit ■ 10-bit or 8-bit resolution ■ Program selection analog input from 32 channels ■ Single conversion, continuous conversion, and scan conversion options ■ Interrupt capability ■ DMA support ■ 4 range comparator channels for comparing conversion output with thresholds
I2S	<ul style="list-style-type: none"> ■ Programmable master/slave operations ■ Supports transmission only, reception only and simultaneous transmission/reception operations ■ Support for 1 sub frame and 2 sub frame constructions ■ Up to 32 channels supported in each sub frame ■ Support for individual configuration of channel number, channel length, word length in each sub frame ■ Word length support from 7-bits to 32-bits ■ Programmable frequency, polarity, and phase of frame synchronous signal ■ Programmable sampling point of received data (center or at the end of received data) ■ Support for frequency division from 1 to 126 in multiples of 2 ■ DMA support ■ Interrupt capability
Sound Generator	<ul style="list-style-type: none"> ■ Produces sound/melody with varying frequency and amplitude ■ Square wave sound output with frequency of 100Hz – 6kHz (resolution 20Hz) ■ Programmable Pulse Width Modulated (PWM) cycle width of 255 or 511 clocks. PWM duty cycle programmable from 0% to 100% ■ Two 2-bit prescaler with programmable clock division of 1, 1/2, 1/3, and 1/4 ■ Automatic linear or exponential amplitude increment or decrement ■ Start, stop, resume functionality ■ DMA support ■ Automatic sound output stop when amplitude becomes 0
Up Down Counter	<ul style="list-style-type: none"> ■ Format: 32-bit or 2 times 16-bit ■ Three count modes (timer mode, up/down count mode, and phase difference count mode) supported ■ Multiply by 2 or multiply by 4 in phase difference count mode ■ Count source can be internal clock or external trigger ■ Counting range: any value between 0 and $2^{32}-1$ can be set ■ 4 interrupt options (Compare-match interrupt, Underflow interrupt, Overflow interrupt, and Count direction change interrupt)
Reload Timers	<ul style="list-style-type: none"> ■ 32-bit reload counter ■ External and Internal clock/event source ■ Trigger signal programmable as rising/falling edge or both ■ Gated count function ■ One-shot or reload counter mode ■ Counter state can be made visible at external pin ■ Prescaler with six different settings for the internal clock and two settings for the external clock ■ Several Reload Timers can be cascaded to form a longer Reload Timer ■ DMA support

Table 2. Device Features (Continued)

Feature	Description
Free Running Timers	<ul style="list-style-type: none"> ■ Signals an interrupt on overflow, match with Compare registers, zero-detection, or match with Compare Clear Register ■ Option to mask zero detection, compare clear match interrupt, or both to allow for interrupt generation only after multiple events ■ Programmable timer period up to 1 s ■ Support for 11 counter clocks. Prescaler with 1, 1/2, 1/4, 1/8, 1/16, 1/32, 1/64, 1/128, 1/256, 1/512, and 1/1024 of peripheral clock frequency ■ DMA support
Input Capture Units	<ul style="list-style-type: none"> ■ Consists of 2 independent input channels ■ 16-bit wide capture registers per channel ■ Signals an interrupt upon external event ■ Rising edge, falling edge or rising & falling edge sensitive ■ DMA support
Output Compare Units	<ul style="list-style-type: none"> ■ Consists of 2 independent channels ■ 16-bit wide ■ Signals an interrupt when a match with 16-bit I/O Timer occurs ■ A pair of compare registers can be used to generate an output signal ■ Interrupt capability
Programmable Pulse Generator	<ul style="list-style-type: none"> ■ 16-bit down counter, cycle and duty setting registers ■ Interrupt at trigger, counter borrow and/or duty match ■ PWM operation and one-shot operation ■ Internal prescaler allows 1, 1/4, 1/16, 1/64 of peripheral clock as counter clock and Reload timer underflow as clock input ■ Can be triggered by software or reload timer
Real Time Clock	<ul style="list-style-type: none"> ■ Can be clocked from main clock, sub clock or RC clock ■ Automatic calibration support even when device is in low power state ■ Interrupt capability on half-second, 1 second, 1 minute, 1 hour, and 1 day duration ■ Additional capability for interrupt generation on calibration failure detection and calibration done event ■ Auto calibration of Sub clock or RC clock with respect to Main clock ■ Separate clock selector for calibration ■ Configurable calibration duration ■ Auto/manual trigger for calibration
Internal Memories- TCMRAM	<ul style="list-style-type: none"> ■ 128 KB ■ 64-bit interface ■ Single error correction, double error detection (SECEDED) ECC support
Internal Memories- System RAM	<ul style="list-style-type: none"> ■ 64-bit AXI interface ■ 64 KB ■ Single error correction, double error detection (SECEDED) ECC support ■ Parallel read/write capability for 2 different banks
Internal Memories- Retention RAM	<ul style="list-style-type: none"> ■ 16 KB ■ 4 banks ■ 32-bit AHB ■ Low leakage RAMs for low power consumption
Tightly Coupled Flash Memory	<ul style="list-style-type: none"> ■ 2 MB ■ Parallel Programming support ■ Mapped to TCM address space as well as Cacheable address space through AXI interface ■ Single error correction, double error detection (SECEDED) ECC support ■ TCM address space supports only read access ■ Cacheable AXI address space supports write and read access ■ Detection of hang-up 1 state ■ 32 large sectors of 64KB each ■ 16 small sectors of 8KB each ■ Sector-wise access protection for write and read accesses

Table 2. Device Features (Continued)

Feature	Description
EEPROM Emulation Flash Memory ¹⁾	<ul style="list-style-type: none"> ■ 48 KB ■ Single error correction, double error detection (SECDED) ECC support ■ Support for sector erase ■ EEPROM emulation mode support ■ Support for mirroring of memory in 3 diverse memory-mapped regions ■ 6 sectors of 8KB each ■ Sector-wise access protection for write and read accesses <p>Note 1. Electronically Erasable and Programmable Read-Only Memory (EEPROM).</p>
Quad SPI	<ul style="list-style-type: none"> ■ Supports legacy as well as the dual-bit and quad-bit modes of SPI operation ■ Supports up to four slave devices in master mode ■ Programmable transfer rate, active-level of slave-select signal, polarity, and phase of the serial clock per slave select ■ Support for memory mapped operation of external serial flash and serial SRAM devices in command sequencer mode ■ Additional direct mode support for standard SPI operation through FIFO interface
Error Collection	<ul style="list-style-type: none"> ■ Error collection on all peripherals ■ Optional Non-Maskable Interrupt (NMI) generation capability
Low Voltage Detect	<ul style="list-style-type: none"> ■ Low voltage detection for 5V, 3.3V, and 1.2V ■ Programmable thresholds ■ Reset generation capability on low voltage events
I/O Ports	<ul style="list-style-type: none"> ■ All functional pins can be used as GPIO ■ Programmable analog or digital functionality selection ■ Programmable input levels (Automotive, CMOS, and TTL) ■ Programmable pull-up/pull-down and output drive
MediaLB	<ul style="list-style-type: none"> ■ Implements ■ Supports 16 logical channels ■ Each logical channel can be programmed as synchronous, asynchronous, isochronous and control channel type and as transmit or receive ■ Loop back mode between the logical channel 0 (reception) and logical channel 1(transmission) ■ Programmable for 256Fs, 512Fs and 1024Fs transfer rates of operation at either 44.0kHz, 48.0kHz, or 48.1kHz. ■ 3-pin mode
SHE	<ul style="list-style-type: none"> ■ Implements all commands defined by the functional specification of SHE (chapter 7) ■ Provides AES-128 encryption and decryption operations ■ Electronic cipher book (ECB) and cipher block chaining (CBC) modes ■ Supports generation of the cipher-based message authentication code (CMAC) ■ Implements Miyaguchi-Preneel compression function. ■ Provides random number generation function ■ Supports secure booting ■ Measurement during / before application start-up ■ Secure boot mode, start address and length of the bootloader are configurable by the user ■ Secure key storage implemented in EEFLASH
CRC	<ul style="list-style-type: none"> ■ Programmable 8, 16, 24 or 32 bit input data width ■ Programmable polynomial value (Polynomial degree from 2 to 32) ■ Programmable initial seed value ■ Programmable final checksum XOR value ■ Interrupt and DMA trigger capability ■ Configurable input/output bit reflection and byte swapping ■ Supports PPU ■ Supports block/multiple data transfers (more than 32-bit)
Packages	QFP-176 (series variant)

Table 3. Memory Map

Start Address	Module
FFFF4000	Reserved
FFFF0000	BOOTROM
FFFEF000	ERCFG_CONFIG
B0D01000	Reserved
B0D00000	SYSTEM_RAM_CONFIG
B0C00000	PERI5_AHB
B0B00000	PERI4_SLAVE
B0A00000	PERI3_ERBUS
B0900000	Reserved
B0800000	PERI1_RBUS
B0700000	PERI0_RBUS
B0600000	MCU_CONFIG
B0500000	DEBUG_BUS
B0400000	MEMORY_CONFIG
B0180000	Reserved
B0100000	GFXCFG
B0080000	Reserved
B0000000	HSSPI0CFG
90000000	Reserved
80000000	HSSPI0_MEMORY
60000000	Reserved
40000000	GFXMEM
06000000	Reserved

Start Address	Module
05FE0000	AXI_SLAVE_CORE0_TCM_FLASH_SMALL_SECTORS
05A00000	Reserved
05800000	AXI_SLAVE_CORE0_TCM_FLASH_LARGE_SECTORS
05020000	Reserved
05000000	AXI_SLAVE_CORE0_TCM_RAM
04800000	AXI_SLAVE_CORE0_DCACHE
04000000	AXI_SLAVE_CORE0_ICACHE
01A10000	Reserved
01A00000	SYSTEM_RAM
01800000	Reserved
017E0000	AXI_FLASH_MEMORY_SMALL_SECTORS
01200000	Reserved
00100000	AXI_FLASH_MEMORY_LARGE_SECTORS
00FE0000	TCM_FLASH_SMALL_SECTORS
00A00000	Reserved
00080000	TCM_FLASH_LARGE_SECTORS
00020000	Reserved
00000000	TCM_RAM

Table 4. HSSPI0 Memory Map

Start Address	Module
B007FC00	BSU8
B0078400	Reserved
B0078000	RICFG8
B0000000	HSSPI0

Table 5. Memory and Config (MEMORY_CONFIG) AHB Bus Memory Map

Start Address	Module
B04C0000	EEFLASH_NOECC_MIR
B0480000	EEFLASH_TABLE_MIR
B0440000	EEFLASH_ECC_MIR
B0418400	Reserved
B0418000	BSU6
B0414400	Reserved
B0414000	MPUXSHE0
B0413400	Reserved
B0413000	SHE_IF_CFG
B0412400	Reserved
B0412000	EEFCFG
B0411400	Reserved
B0411000	TCFCFG

Table 5. Memory and Config (MEMORY_CONFIG) AHB Bus Memory Map (Continued)

Start Address	Module
B0410400	Reserved
B0410000	TRCFG
B0408400	Reserved
B0408000	TPU0
B0404000	Reserved
B0400000	IRQ0

Table 6. MCU_CONFIG AHB Bus Memory Map

Start Address	Module
B06FFC00	BSU7
B06F8000	RICFG7
B0648000	Reserved
B063B000	RETRAMBANK3
B063A000	RETRAMBANK2
B0639000	RETRAMBANK1
B0638000	RETRAMBANK0
B0628400	Reserved
B0628000	EICU0
B0620400	Reserved
B0620000	EIC0
B0618400	Reserved
B0618000	RTC
B0610400	Reserved
B0610000	RRCFG
B0608400	Reserved
B0608000	WDG
B0601000	Reserved
B0600000	SYSC

Table 7. PERI0_RBUS Memory Map

Start Address	Module
B07FFC00	BSU0
B07F8000	RICFG0
B07F0400	Reserved
B07F0000	BECU0
B07EC000	Reserved
B07E8000	PPC
B074C400	Reserved
B074C000	PPGGLC0
B0748C00	PPGGRP3
B0748800	PPGGRP2

Table 7. PERI0_RBUS Memory Map (Continued)

Start Address	Module
B0748400	PPGGRP1
B0748000	PPGGRP0
B073BC00	PPG15
B073B800	PPG14
B073B400	PPG13
B073B000	PPG12
B073AC00	PPG11
B073A800	PPG10
B073A400	PPG9
B073A000	PPG8
B0739C00	PPG7
B0739800	PPG6
B0739400	PPG5
B0739000	PPG4
B0738C00	PPG3
B0738800	PPG2
B0738400	PPG1
B0738000	PPG0
B0731C00	Reserved
B0731800	SMCTG0
B0731400	SMC5
B0731000	SMC4
B0730C00	SMC3
B0730800	SMC2
B0730400	SMC1
B0730000	SMC0
B0729800	Reserved
B0728000	USART0
B0720C00	Reserved
B0720000	I2C0
B071C000	Reserved
B0718400	OCU1
B0718000	OCU0
B0714000	Reserved
B0710C00	ICU3
B0710800	ICU2
B070C000	Reserved
B0708C00	FRT3
B0708800	FRT2
B0708400	FRT1
B0708000	FRT0

Table 7. PERI0_RBUS Memory Map (Continued)

Start Address	Module
B0700400	Reserved
B0700000	ADC0

Table 8. PERI1_RBUS Memory Map

Start Address	Module
B08FFC00	BSU1
B08F8000	RICFG1
B08F0400	Reserved
B08F0000	BECU1
B085C400	Reserved
B085C000	PPGGLC1
B0858400	PPGGRP17
B0858000	PPGGRP16
B0849C00	PPG71
B0849800	PPG70
B0849400	PPG69
B0849000	PPG68
B0848C00	PPG67
B0848800	PPG66
B0848400	PPG65
B0848000	PPG64
B0839800	Reserved
B0838000	USART6
B082C000	Reserved
B0828400	OCU17
B0828000	OCU16
B0824000	Reserved
B0820C00	ICU19
B0820800	ICU18
B081C000	Reserved
B0818C00	FRT19
B0818800	FRT18
B0818400	FRT17
B0818000	FRT16
B080A000	Reserved
B0808400	CAN1
B0808000	CAN0
B0801000	Reserved
B0800000	SG0

Table 9. PERI3_eRBUS Memory Map

Start Address	Module
B0AFFC00	BSU3
B0AF8000	RICFG3
B0AF0400	Reserved
B0AF0000	BECU3
B0A21000	Reserved
B0A20000	UDC0
B0A18000	Reserved
B0A12400	RLT9
B0A12000	RLT8
B0A11C00	RLT7
B0A11800	RLT6
B0A11400	RLT5
B0A11000	RLT4
B0A10C00	RLT3
B0A10800	RLT2
B0A10400	RLT1
B0A10000	RLT0
B0A09000	Reserved
B0A08000	GPIO
B0A00400	Reserved
B0A00000	PPU0

Table 10. PERI4_SLAVE AHB Bus Memory Map

Start Address	Module
B0BFFC00	BSU4
B0BF8000	RICFG4
B0B40400	Reserved
B0B40000	ARH0
B0B3B000	Reserved
B0B38800	SPI2
B0B38400	SPI1
B0B38000	SPI0
B0B30800	Reserved
B0B30000	CRC0
B0B22000	Reserved
B0B20400	I2S1
B0B20000	I2S0
B0B10800	Reserved
B0B10400	MPUHMLB0

Table 10. PERI4_SLAVE AHB Bus Memory Map (Continued)

Start Address	Module
B0B10000	MLB0
B0B00400	Reserved
B0B00000	MPUXGFX

Table 11. PERI5_AHB Bus Memory Map

Start Address	Module
B0CFFC00	BSU5
B0C09000	Reserved
B0C08000	MPUXDMA0
B0C04000	Reserved
B0C00000	DMA0
B0800000	PERI1_RBUS
B0700000	PERI0_RBUS

Resource Distribution for Non-modulated Clock

Some of the resources are available with modulated and non-modulated clock. [Table 12](#) provides the distribution.

Table 12. Clock Modulation for Resources

Module	Non-modulated	Modulation Possible
CAN	2	-
SG	1	-
ICU/OCU/FRT	4	4
PPG	8	16
USART/LIN	1	1
I2C	1	-
SMC	-	6

Lock/Unlock Values for Protection Units

For various protection and system relevant units, registers must be unlocked before configuring and can be locked for protection. For the details about functionality, see the FCR4 Hardware Manual.

Table 13. Lock/Unlock Values for FCR4 Protection Module Instances

Module	Unlock Value	Lock Value
TPU0	ACC5A110	B10CACC5
PPU0	ACC5BB01	BB0B10C1
MPUHMLB0	D76ACC01	D76B10C1
MPUXDMA0	ACCABB56	112ABB56
MPUXGFX	01ACC384	0B10C834
MPUXSHE0	0x15EDDE51	10CE0EB1
TRCFG	ACC55ECC	5ECCB10C
EXCFG	ACC5B007	B007ECF6
IRQ0	17ACC911	17B10C11
RRCFG	ACC5DECC	DECCB10C
SCCFG	5ECACCE5	A135331A
SRCFG	5ECC551F	551FB10C
GFXSIG	A1ACC384	AB10C834
GFXGCTR	7E1ECA57	D15AB1E0
TCFCFG	CF61F1A5	
EEFCFG	CF6DF1A5	
WDG	EDACCE55	
SYSC	5CACCE55	

ID-Values for Module Identification Registers

For several peripheral and system related modules, the hardware contains Module Identification Registers that hold read-only values which contain information about the module number, the version and possible patches.

Table 14. Module ID List

Module	ID-Register	ID Value
System Controller	SYSC_SYSIDR	0x00041100
Security Checker	SCCFG_MODID	0x00020400
SRAM Interface	SRCFG_MID	0x00040300
TC-Flash Interface	TCFCFG_FMIDR	0x000E0400
EE-Flash Interface	EEFCFG_MIR	0x00090700
Interrupt Controller 0	IRQ0_MID	0x000B0100
DMA Controller 0	DMA0_ID	0x00010400
Timing Protection Unit 0	TPU0_MID	0x00050200
Memory Protection Unit for DMA	MPUXDMA0_MID	0x000D0200
Memory Protection Unit for GFX	MPUXGFX_MID	0x000D0200
Memory Protection Unit for SHE	MPUXSHE0_MID	0x000D0200
Memory Protection Unit for MLB	MPUHMLB0_MID	0x00110100
Bus Error Collection Unit 0	BECU0_MIDH / BECU0_MIDL	0x0008 / 0x0300
Bus Error Collection Unit 1	BECU1_MIDH / BECU1_MIDL	0x0008 / 0x0300
Bus Error Collection Unit 3	BECU3_MIDH / BECU3_MIDL	0x0008 / 0x0300
High Speed SPI Interface 0	HSSPI0_MID	0x00060400
SPI Interface 0	SPI0_MID	0x00070400
SPI Interface 1	SPI1_MID	0x00070400
SPI Interface 2	SPI2_MID	0x00070400
Inter IC Sound 0	I2S0_MIDREG	0x000A0300
Inter IC Sound 1	I2S1_MIDREG	0x000A0300
SHE	SHE_IF_CFG_MID	0x000F0200

Package and Pin Assignment

Package

QFP-176 package will be used for CY9EF226. The package code is LQP176.

QFP-176 Pin Assignment

Figure 1. QFP-176 Pin Assignment

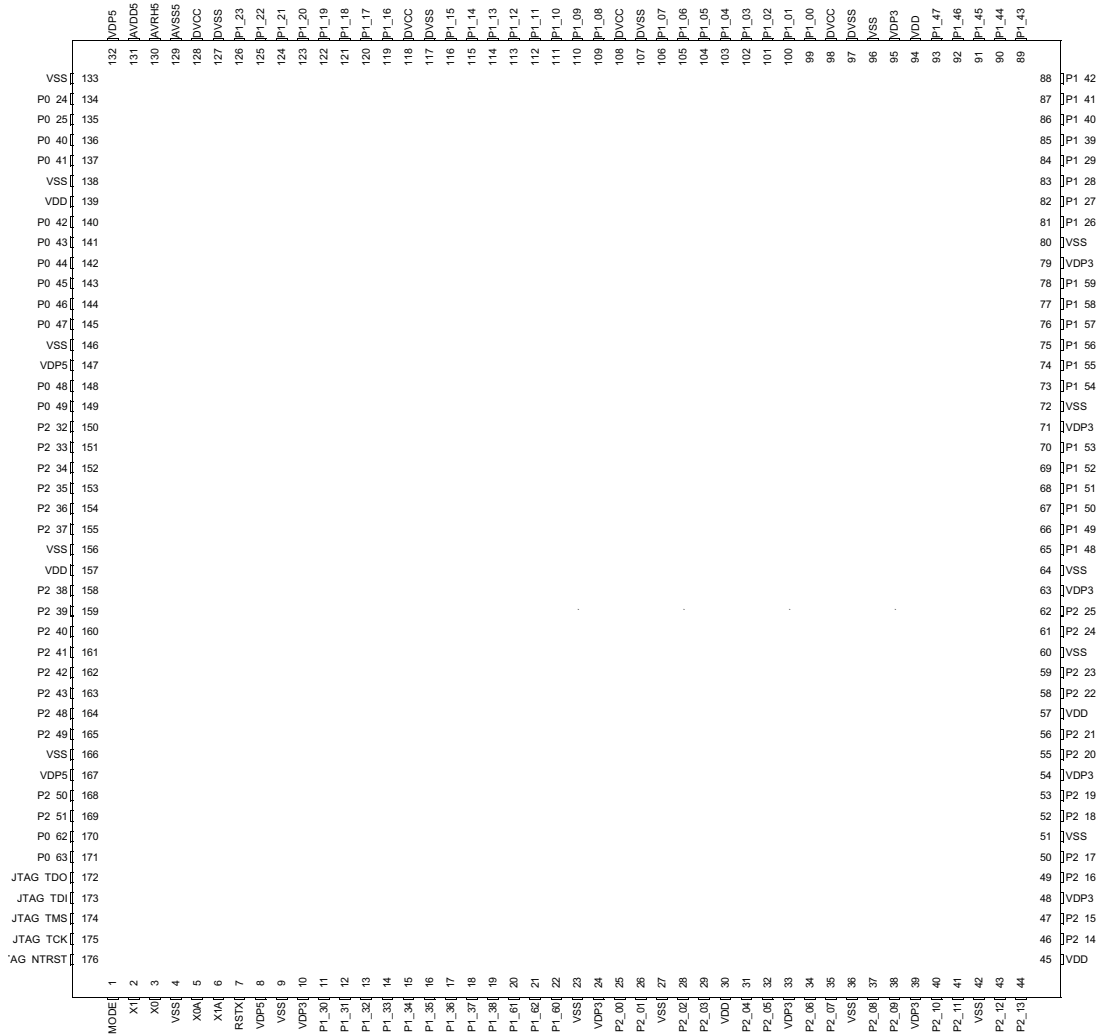

Table 15. QFP-176 Package Pinout

Pin Number	Pin Name
1	MODE
2	X1
3	X0
4	VSS
5	X0A
6	X1A
7	RSTX
8	VDP5
9	VSS
10	VDP3
11	P1_30
12	P1_31
13	P1_32
14	P1_33
15	P1_34
16	P1_35
17	P1_36
18	P1_37
19	P1_38
20	P1_61
21	P1_62
22	P1_60
23	VSS
24	VDP3
25	P2_00
26	P2_01
27	VSS
28	P2_02
29	P2_03
30	VDD
31	P2_04
32	P2_05
33	VDP3
34	P2_06
35	P2_07
36	VSS
37	P2_08
38	P2_09
39	VDP3
79	VDP3
80	VSS

Pin Number	Pin Name
40	P2_10
41	P2_11
42	VSS
43	P2_12
44	P2_13
45	VDD
46	P2_14
47	P2_15
48	VDP3
49	P2_16
50	P2_17
51	VSS
52	P2_18
53	P2_19
54	VDP3
55	P2_20
56	P2_21
57	VDD
58	P2_22
59	P2_23
60	VSS
61	P2_24
62	P2_25
63	VDP3
64	VSS
65	P1_48
66	P1_49
67	P1_50
68	P1_51
69	P1_52
70	P1_53
71	VDP3
72	VSS
73	P1_54
74	P1_55
75	P1_56
76	P1_57
77	P1_58
78	P1_59
118	DVCC
119	P1_16

Table 15. QFP-176 Package Pinout (Continued)

Pin Number	Pin Name
81	P1_26
82	P1_27
83	P1_28
84	P1_29
85	P1_39
86	P1_40
87	P1_41
88	P1_42
89	P1_43
90	P1_44
91	P1_45
92	P1_46
93	P1_47
94	VDD
95	VDP3
96	VSS
97	DVSS
98	DVCC
99	P1_00
100	P1_01
101	P1_02
102	P1_03
103	P1_04
104	P1_05
105	P1_06
106	P1_07
107	DVSS
108	DVCC
109	P1_08
110	P1_09
111	P1_10
112	P1_11
113	P1_12
114	P1_13
115	P1_14
116	P1_15
117	DVSS
157	VDD
158	P2_38
159	P2_39
160	P2_40

Pin Number	Pin Name
120	P1_17
121	P1_18
122	P1_19
123	P1_20
124	P1_21
125	P1_22
126	P1_23
127	DVSS
128	DVCC
129	AVSS5
130	AVRH5
131	AVDD5
132	VDP5
133	VSS
134	P0_24
135	P0_25
136	P0_40
137	P0_41
138	VSS
139	VDD
140	P0_42
141	P0_43
142	P0_44
143	P0_45
144	P0_46
145	P0_47
146	VSS
147	VDP5
148	P0_48
149	P0_49
150	P2_32
151	P2_33
152	P2_34
153	P2_35
154	P2_36
155	P2_37
156	VSS
173	JTAG_TDI
174	JTAG_TMS
175	JTAG_TCK
176	JTAG_NTRST

Table 15. QFP-176 Package Pinout (Continued)

Pin Number	Pin Name	Pin Number	Pin Name
161	P2_41	167	VDP5
162	P2_42	168	P2_50
163	P2_43	169	P2_51
164	P2_48	170	P0_62
165	P2_49	171	P0_63
166	VSS	172	JTAG_TDO

I/O Pins and Functions

IO Pin configuration needs to be done by writing into Port Pin Multiplexing registers and Resource Input Configuration registers which are described in [Port Pin Multiplexing](#) and [Resource Input Source](#). GPIO_PPERn register must be enabled before starting IO Pin configuration, since GPIO_PPERn enables corresponding pin of the device.

Note Since writing GPIO PPERn registers are required for both Portmux & resource-mux registers.

Port Pin Multiplexing

Table 16. Port Multiplexing

Register (Offset)	Resource Functional Output									Possible Resource Function Input
	Port	POF=0	POF=1	POF=2	POF=3	POF=4	POF=5	POF=6	POF=7	
PCFGR024 (0x0030)	P0_24	GPIO0_24o		OCU0_OTD0_GI		PPG8_PPGB	OCU0_OTD0	RLT3_TOT	PPG0_PPGA	GPIO0_24i, EIC0_INT09, EIC0_INT10, CAN1_RX, ICU2_IN0
PCFGR025 (0x0032)	P0_25	GPIO0_25o		OCU0_OTD1_GI	CAN1_TX	PPG9_PPGB	OCU0_OTD1	RLT4_TOT	PPG1_PPGA	GPIO0_25i, EIC0_INT08, CAN0_RX, ICU2_IN1, ADC0_AN25
PCFGR040 (0x0050)	P0_40	GPIO0_40o	SPI2_SSo	RTC_WOT		PPG64_PPGB	OCU16_OTD0_G		PPG8_PPGA	GPIO0_40i, EIC0_INT05, EIC0_INT12, EIC0_INT11, SPI2_SSi, USART6_SIN, USART0_SIN, FRT0_FRCK, RLT5_TIN, ADC0_AN15
PCFGR041 (0x0052)	P0_41	GPIO0_41o	SPI2_DATA1o	SYSC_CKOT	USART6_SCKo	PPG65_PPGB	OCU16_OTD1_G		PPG9_PPGA	GPIO0_41i, EIC0_INT15, SPI2_DATA1i, USART6_SCKi, USART0_SCKi, FRT1_FRCK, RLT6_TIN, ICU2_IN0, ICU18_IN1, ADC0_AN16
PCFGR042 (0x0054)	P0_42	GPIO0_42o	SPI2_DATA0o	SYSC_CKOTX	USART6_SOT	PPG66_PPGB	OCU17_OTD0_G	RLT2_TOT	PPG10_PPGA	GPIO0_42i, EIC0_INT08, EIC0_INT10, EIC0_INT11, SPI2_DATA0i, CAN0_RX, FRT2_FRCK, CAN1_RX, ICU2_IN1, ICU19_IN0, USART0_SIN, ADC0_AN17
PCFGR043 (0x0056)	P0_43	GPIO0_43o	SPI2_CLKo	WDG_OBSERVE	CAN0_TX	PPG67_PPGB	OCU17_OTD1_G		PPG11_PPGA	GPIO0_43i, EIC0_INT09, SPI2_CLKi, CAN1_RX, FRT3_FRCK, RLT2_TIN, ADC0_AN18
PCFGR044 (0x0058)	P0_44	GPIO0_44o	SPI0_SSo	SPI2_SSO2	SPI2_DATA2o	PPG68_PPGB	OCU0_OTD0_G	RLT3_TOT	PPG12_PPGA	GPIO0_44i, EIC0_INT03, SPI2_DATA2i, SPI0_SSi, FRT16_FRCK, UDC0_AIN0, ADC0_AN19

Table 16. Port Multiplexing (Continued)

Register (Offset)	Resource Functional Output									Possible Resource Function Input	
	Port	POF=0	POF=1	POF=2	POF=3	POF=4	POF=5	POF=6	POF=7		
PCFGR045 (0x005A)	P0_45	GPIO0_45o	SPI0_DATA1o	SPI2_SSO3	SPI2_DATA3o	PPG69_PPGB	OCU0_OTD1_G			PPG13_PPGA	GPIO0_45i, EIC0_INT11, EIC0_INT12, FRT16_FRCK, FRT18_FRCK, SPI2_DATA3i, SPI0_DATA1i, USART0_SIN, USART6_SIN, FRT17_FRCK, RLT3_TIN, FRT19_FRCK, UDC0_BIN0, ADC0_AN20
PCFGR046 (0x005C)	P0_46	GPIO0_46o	SPI0_DATA0o	SPI2_SSO1	USART0_SCKo	PPG70_PPGB	OCU1_OTD0_G			PPG14_PPGA	GPIO0_46i, EIC0_INT16, SPI0_DATA0i, USART0_SCKi, USART6_SCKi, FRT18_FRCK, RLT4_TIN, UDC0_ZIN0, ICU18_IN0, ADC0_AN21
PCFGR047 (0x005E)	P0_47	GPIO0_47o	SPI0_CLKo	UDC0_UDOT0	USART0_SCKo	PPG71_PPGB	OCU1_OTD1_G	OCU16_OTD0_G		PPG15_PPGA	GPIO0_47i, FRT0_FRCK, FRT1_FRCK, FRT2_FRCK, EIC0_INT17, FRT3_FRCK, SPI0_CLKi, FRT16_FRCK, FRT17_FRCK, FRT19_FRCK, RLT0_TIN, FRT18_FRCK, EIC0_INT12, ICU18_IN1, USART6_SIN, ADC0_AN22
PCFGR048 (0x0060)	P0_48	GPIO0_48o	SPI1_SSo	SPI0_SSO2	SPI0_DATA2o	PPG0_PPGB	OCU0_OTD0	RLT4_TOT		PPG64_PPGA	GPIO0_48i, EIC0_INT04, EIC0_INT09, EIC0_INT08, SPI0_DATA2i, SPI1_SSi, CAN1_RX, CAN0_RX, ICU2_IN0, UDC0_AIN1, ADC0_AN23
PCFGR049 (0x0062)	P0_49	GPIO0_49o	SPI1_DATA1o	SPI0_SSO1	CAN1_TX	PPG1_PPGB	OCU0_OTD1	RLT0_TOT		PPG65_PPGA	GPIO0_49i, EIC0_INT10, SPI1_DATA1i, ICU2_IN1, CAN0_RX, UDC0_BIN1, ADC0_AN24
PCFGR062 (0x007C)	P0_62	GPIO0_62o	I2C0_SCLo								GPIO0_62i, EIC0_INT24, I2C0_SCLi
PCFGR063 (0x007E)	P0_63	GPIO0_63o	I2C0_SDAo								GPIO0_63i, EIC0_INT00, I2C0_SDAi
PCFGR100 (0x0080)	P1_00	GPIO1_00o	SMC0_M2			PPG64_PPGB				PPG0_PPGA	GPIO1_00i, CAN0_RX, EIC0_INT08, EIC0_INT25, ADC0_AN26
PCFGR101 (0x0082)	P1_01	GPIO1_01o	SMC0_P2			PPG65_PPGB	CAN0_TX			PPG1_PPGA	GPIO1_01i, EIC0_INT26, ADC0_AN26
PCFGR102 (0x0084)	P1_02	GPIO1_02o	SMC0_M1			PPG66_PPGB				PPG2_PPGA	GPIO1_02i, EIC0_INT13, CAN1_RX, EIC0_INT09, ADC0_AN26

Table 16. Port Multiplexing (Continued)

Register (Offset)	Resource Functional Output									Possible Resource Function Input
	Port	POF=0	POF=1	POF=2	POF=3	POF=4	POF=5	POF=6	POF=7	
PCFGR103 (0x0086)	P1_03	GPIO1_03o	SMC0_P1			PPG67_PPGB	CAN1_TX		PPG3_PPGB	GPIO1_03i, EIC0_INT27, ADC0_AN26
PCFGR104 (0x0088)	P1_04	GPIO1_04o	SMC1_M2			PPG68_PPGB			PPG4_PPGB	GPIO1_04i, EIC0_INT28, ADC0_AN27
PCFGR105 (0x008A)	P1_05	GPIO1_05o	SMC1_P2			PPG69_PPGB			PPG5_PPGB	GPIO1_05i, EIC0_INT29, ADC0_AN27
PCFGR106 (0x008C)	P1_06	GPIO1_06o	SMC1_M1			PPG70_PPGB			PPG6_PPGB	GPIO1_06i, EIC0_INT30, ADC0_AN27
PCFGR107 (0x008E)	P1_07	GPIO1_07o	SMC1_P1			PPG71_PPGB			PPG7_PPGB	GPIO1_07i, EIC0_INT31, ADC0_AN27
PCFGR108 (0x0090)	P1_08	GPIO1_08o	SMC2_M2			PPG0_PPGB	SPI0_SS0		PPG8_PPGB	GPIO1_08i, USART0_SIN, RLT3_TIN, EIC0_INT00, SPI0_SSI, ADC0_AN28, EIC0_INT03, EIC0_INT11
PCFGR109 (0x0092)	P1_09	GPIO1_09o	SMC2_P2			PPG1_PPGB	SPI0_DATA1o	USART0_SCKo	PPG9_PPGB	GPIO1_09i, USART0_SCKi, RLT4_TIN, EIC0_INT01, SPI0_DATA1i, ICU2_IN1, ADC0_AN28
PCFGR110 (0x0094)	P1_10	GPIO1_10o	SMC2_M1			PPG2_PPGB	SPI0_DATA0o	USART0_SOT	PPG10_PPGB	GPIO1_10i, EIC0_INT02, SPI0_DATA0i, ICU2_IN0, ADC0_AN28
PCFGR111 (0x0096)	P1_11	GPIO1_11o	SMC2_P1			PPG3_PPGB	SPI0_CLKo		PPG11_PPGB	GPIO1_11i, EIC0_INT03, SPI0_CLKi, RLT0_TIN, ADC0_AN28
PCFGR112 (0x0098)	P1_12	GPIO1_12o	SMC3_M2			PPG4_PPGB	SPI1_SS0		PPG12_PPGB	GPIO1_12i, USART6_SIN, RLT5_TIN, EIC0_INT04, SPI1_SSI, ADC0_AN29, EIC0_INT12
PCFGR113 (0x009A)	P1_13	GPIO1_13o	SMC3_P2			PPG5_PPGB	SPI1_DATA1o	USART6_SCKo	PPG13_PPGB	GPIO1_13i, USART6_SCKi, RLT6_TIN, EIC0_INT05, SPI1_DATA1i, ICU18_IN0, ADC0_AN29
PCFGR114 (0x009C)	P1_14	GPIO1_14o	SMC3_M1			PPG6_PPGB	SPI1_DATA0o	USART6_SOT	PPG14_PPGB	GPIO1_14i, EIC0_INT06, SPI1_DATA0i, ICU19_IN1, ADC0_AN29
PCFGR115 (0x009E)	P1_15	GPIO1_15o	SMC3_P1			PPG7_PPGB	SPI1_CLKo		PPG15_PPGB	GPIO1_15i, EIC0_INT07, SPI1_CLKi, RLT1_TIN, ADC0_AN29
PCFGR116 (0x00A0)	P1_16	GPIO1_16o	SMC4_M2			PPG8_PPGB	SPI2_SS0	SPI1_SSO2	PPG64_PPGB	GPIO1_16i, EIC0_INT10, EIC0_INT13, SPI2_SSI, ADC0_AN30, EIC0_INT05
PCFGR117 (0x00A2)	P1_17	GPIO1_17o	SMC4_P2			PPG9_PPGB	SPI2_DATA1o	SPI1_SSO1	PPG65_PPGB	GPIO1_17i, EIC0_INT14, SPI2_DATA1i, ADC0_AN30

Table 16. Port Multiplexing (Continued)

Register (Offset)	Resource Functional Output									Possible Resource Function Input
	Port	POF=0	POF=1	POF=2	POF=3	POF=4	POF=5	POF=6	POF=7	
PCFGR118 (0x00A4)	P1_18	GPIO1_18o	SMC4_M1	SG0_SGA	DMA0_DR EQ_ACK1	PPG10_PPGB	SPI2_DATA0o	SPI1_SSO 3	PPG66_PPGA	GPIO1_18i, EIC0_INT15, SPI2 - DATA0i, ICU18_IN0, ADC0_AN30
PCFGR119 (0x00A6)	P1_19	GPIO1_19o	SMC4_P1	SG0_SGO	DMA0_D-STP_ACK1	PPG11_PPGB	SPI2_CLKo		PPG67_PPGA	GPIO1_19i, EIC0_INT16, SPI2_CLKi, ICU19_IN1, RLT2_TIN, ADC0_AN30
PCFGR120 (0x00A8)	P1_20	GPIO1_20o	SMC5_M2		DMA0_DE OP1	PPG12_PPGB			PPG68_PPGA	GPIO1_20i, EIC0_INT17, ADC0_AN31
PCFGR121 (0x00AA)	P1_21	GPIO1_21o	SMC5_P2			PPG13_PPGB			PPG69_PPGA	GPIO1_21i, EIC0_INT18, DMA0_DREQ1, ADC0_AN31
PCFGR122 (0x00AC)	P1_22	GPIO1_22o	SMC5_M1			PPG14_PPGB			PPG70_PPGA	GPIO1_22i, EIC0_INT19, DMA0_DSTP1, ADC0_AN31
PCFGR123 (0x00AE)	P1_23	GPIO1_23o	SMC5_P1			PPG15_PPGB			PPG71_PPGA	GPIO1_23i, EIC0_INT20, DMA0_D-EOP_ACK1, ADC0_AN31
PCFGR126 (0x00B4)	P1_26	GPIO1_26o	DBG0_TRAC E0	DMA0_DEO P0	I2S1_WSo	PPG7_PPGB	OCU17_OTD1		PPG71_PPGA	GPIO1_26i, EIC0_INT07, I2S1_Wsi, ICU19_IN1
PCFGR127 (0x00B6)	P1_27	GPIO1_27o	DBG0_TRAC E1		I2S1_SCKo					GPIO1_27i, EIC0_INT21, DMA0_DREQ0, I2S1_SCKi
PCFGR128 (0x00B8)	P1_28	GPIO1_28o	DBG0_CTL					RLT3_TOT		GPIO1_28i, EIC0_INT22, DMA0_DSTP0
PCFGR129 (0x00BA)	P1_29	GPIO1_29o	DBG0_CLK					RLT4_TOT		GPIO1_29i, EIC0_INT23, DMA0_DEOP_ACK0
PCFGR130 (0x00BC)	P1_30	GPIO1_30o	HSSPI0_SSO 3	OCU0_OTD0		DBG0_TRACE 2	DMA0_DREQ_A CK0			GPIO1_30i, EIC0_INT11, PPG_ETRG2, GFX0_DCLKi, USART0_SIN, RLT3_TIN, ADC0_EDGI
PCFGR131 (0x00BE)	P1_31	GPIO1_31o	HSSPI0_SSO 2	OCU0_OTD1	USART0_S CKo	DBG0_TRACE 3	DMA0_DST-P_ACK0			GPIO1_31i, EIC0_INT24, USART0_SCKi, ICU3_IN1, RLT4_TIN
PCFGR132 (0x00C0)	P1_32	GPIO1_32o	HSSPI0_SSO 1	OCU1_OTD0	USART0_S OT	DBG0_TRACE 4				GPIO1_32i, EIC0_INT25, ICU3_IN0
PCFGR133 (0x00C2)	P1_33	GPIO1_33o	HSSPI0_SSo	OCU1_OTD1	CAN0_TX	DBG0_TRACE 5				GPIO1_33i, EIC0_INT01, HSSPI0_SSi
PCFGR134 (0x00C4)	P1_34	GPIO1_34o	HSSPI0 - DATA3o							GPIO1_34i, EIC0_INT08, HSSPI0_DATA3i, CAN0_RX, UDC0_AIN0
PCFGR135 (0x00C6)	P1_35	GPIO1_35o	HSSPI0 - DATA2o		CAN1_TX					GPIO1_35i, EIC0_INT26, HSSPI0_DATA2i, ICU2_IN0, UDC0_BIN0

Table 16. Port Multiplexing (Continued)

Register (Offset)	Resource Functional Output									Possible Resource Function Input
	Port	POF=0	POF=1	POF=2	POF=3	POF=4	POF=5	POF=6	POF=7	
PCFGR136 (0x00C8)	P1_36	GPIO1_36o	HSSPI0_-DATA1o							GPIO1_36i, EIC0_INT09, HSSPI0_DATA1i, CAN1_RX, ICU2_IN1, UDC0_ZIN0
PCFGR137 (0x00CA)	P1_37	GPIO1_37o	HSSPI0_-DATA0o	UDC0_UDOT0				RLT5_TOT		GPIO1_37i, EIC0_INT13, HSSPI0_DATA0i, ICU3_IN0
PCFGR138 (0x00CC)	P1_38	GPIO1_38o	HSSPI0_CLKo					RLT6_TOT		GPIO1_38i, EIC0_INT10, HSSPI0_CLKi, ICU3_IN1/
PCFGR139 (0x00CE)	P1_39	GPIO1_39o	GFXSPI_SSO3	OCU16_OTD0						GPIO1_39i, EIC0_INT12, GFX0_DCLKi, USART6_SIN, RLT5_TIN
PCFGR140 (0x00D0)	P1_40	GPIO1_40o	GFXSPI_SSO2	OCU16_OTD1	USART6_SCKo	DBG0_TRACE6				GPIO1_40i, EIC0_INT27, PPG_ETRG3, USART6_SCKi, RLT6_TIN, ADC0_EDGI, ICU2_IN0
PCFGR141 (0x00D2)	P1_41	GPIO1_41o	GFXSPI_SSO1	OCU17_OTD0	USART6_SOT	DBG0_TRACE7		RLT3_TOT		GPIO1_41i, EIC0_INT28, ICU2_IN1
PCFGR142 (0x00D4)	P1_42	GPIO1_42o	GFXSPI_SSo	OCU17_OTD1		PPG70_PPGB		RLT4_TOT	PPG6_PPGA	GPIO1_42i, EIC0_INT02, GFXSPI_SSi
PCFGR143 (0x00D6)	P1_43	GPIO1_43o	GFXSPI_-DATA3o			PPG71_PPGB			PPG7_PPGA	GPIO1_43i, EIC0_INT11, GFXSPI_DATA3i, USART0_SIN, ICU18_IN0, RLT3_TIN, UDC0_AIN1
PCFGR144 (0x00D8)	P1_44	GPIO1_44o	GFXSPI_-DATA2o		USART0_SCKo	PPG0_PPGB			PPG8_PPGA	GPIO1_44i, EIC0_INT29, GFXSPI_DATA2i, USART0_SCKi, ICU18_IN1, RLT4_TIN, UDC0_BIN1
PCFGR145 (0x00DA)	P1_45	GPIO1_45o	GFXSPI_-DATA1o		USART0_SOT	PPG1_PPGB			PPG9_PPGA	GPIO1_45i, EIC0_INT30, GFXSPI_DATA1i, ICU19_IN0, UDC0_ZIN1
PCFGR146 (0x00DC)	P1_46	GPIO1_46o	GFXSPI_-DATA0o	UDC0_UDOT1		PPG2_PPGB			PPG10_PPGA	GPIO1_46i, EIC0_INT31, GFXSPI_DATA0i, ICU19_IN1
PCFGR147 (0x00DE)	P1_47	GPIO1_47o	GFXSPI_CLKo			PPG3_PPGB			PPG11_PPGA	GPIO1_47i, EIC0_INT00, GFXSPI_CLKi
PCFGR148 (0x00E0)	P1_48	GPIO1_48o	GFX0_TSIG0			PPG4_PPGB			PPG12_PPGA	GPIO1_48i, EIC0_INT01
PCFGR149 (0x00E2)	P1_49	GPIO1_49o	GFX0_TSIG1			PPG5_PPGB			PPG13_PPGA	GPIO1_49i, EIC0_INT02
PCFGR150 (0x00E4)	P1_50	GPIO1_50o	GFX0_TSIG2			PPG6_PPGB			PPG14_PPGA	GPIO1_50i, EIC0_INT14
PCFGR151 (0x00E6)	P1_51	GPIO1_51o	GFX0_TSIG3			PPG7_PPGB			PPG15_PPGA	GPIO1_51i, EIC0_INT15
PCFGR152 (0x00E8)	P1_52	GPIO1_52o	GFX0_TSIG4	UDC0_UDOT0		PPG8_PPGB			PPG64_PPGA	GPIO1_52i, EIC0_INT16, ICU2_IN0

Table 16. Port Multiplexing (Continued)

Register (Offset)	Resource Functional Output									Possible Resource Function Input
	Port	POF=0	POF=1	POF=2	POF=3	POF=4	POF=5	POF=6	POF=7	
PCFGR153 (0x00EA)	P1_53	GPIO1_53o	GFX0_TSIG5			PPG9_PPGB			PPG65_PPGA	GPIO1_53i, EIC0_INT17, ICU2_IN1, UDC0_AIN0
PCFGR154 (0x00EC)	P1_54	GPIO1_54o	GFX0_TSIG6			PPG10_PPGB			PPG66_PPGA	GPIO1_54i, EIC0_INT18, ICU3_IN0, UDC0_BIN0
PCFGR155 (0x00EE)	P1_55	GPIO1_55o	GFX0_TSIG7			PPG11_PPGB			PPG67_PPGA	GPIO1_55i, EIC0_INT19, ICU3_IN1, UDC0_ZIN0
PCFGR156 (0x00F0)	P1_56	GPIO1_56o	GFX0_TSIG8	UDC0_UDOT1		PPG12_PPGB			PPG68_PPGA	GPIO1_56i, EIC0_INT20, ICU18_IN0
PCFGR157 (0x00F2)	P1_57	GPIO1_57o	GFX0_TSIG9			PPG13_PPGB			PPG69_PPGA	GPIO1_57i, EIC0_INT21, ICU18_IN1, UDC0_AIN1
PCFGR158 (0x00F4)	P1_58	GPIO1_58o	GFX0_TSIG10			PPG14_PPGB			PPG70_PPGA	GPIO1_58i, EIC0_INT22, ICU19_IN0, UDC0_BIN1
PCFGR159 (0x00F6)	P1_59	GPIO1_59o	GFX0_TSIG11			PPG15_PPGB			PPG71_PPGA	GPIO1_59i, EIC0_INT23, ICU19_IN1, UDC0_ZIN1
PCFGR160 (0x00F8)	P1_60	GPIO1_60o	OCU17_OTD1	OCU17_OTD1_G	OCU17_OTD1_I	PPG70_PPGB	OCU17_OTD1_G	RLT4_TOT	PPG6_PPGA	GPIO1_60i, MLB0_CLKI, EIC0_INT00
PCFGR161 (0x00FA)	P1_61	GPIO1_61o	MLB0_SIGo							GPIO1_61i, MLB0_SIGi, EIC0_INT01
PCFGR162 (0x00FC)	P1_62	GPIO1_62o	MLB0_DATo							GPIO1_62i, MLB0_DATi, EIC0_INT02
PCFGR200 (0x0100)	P2_00	GPIO2_00o	GFX0_DISP0			PPG64_PPGB			PPG0_PPGA	GPIO2_00i, EIC0_INT21
PCFGR201 (0x0102)	P2_01	GPIO2_01o	GFX0_DISP1			PPG65_PPGB			PPG1_PPGA	GPIO2_01i, EIC0_INT22
PCFGR202 (0x0104)	P2_02	GPIO2_02o	GFX0_DISP2			PPG66_PPGB			PPG2_PPGA	GPIO2_02i, EIC0_INT23, FRT0_FRCK
PCFGR203 (0x0106)	P2_03	GPIO2_03o	GFX0_DISP3			PPG67_PPGB			PPG3_PPGA	GPIO2_03i, EIC0_INT24, FRT1_FRCK
PCFGR204 (0x0108)	P2_04	GPIO2_04o	GFX0_DISP4			PPG68_PPGB			PPG4_PPGA	GPIO2_04i, EIC0_INT25, FRT2_FRCK, ICU2_IN0
PCFGR205 (0x010A)	P2_05	GPIO2_05o	GFX0_DISP5			PPG69_PPGB			PPG5_PPGA	GPIO2_05i, EIC0_INT26, FRT3_FRCK, ICU2_IN1
PCFGR206 (0x010C)	P2_06	GPIO2_06o	GFX0_DISP6			PPG70_PPGB			PPG6_PPGA	GPIO2_06i, EIC0_INT27, FRT16_FRCK, ICU3_IN0
PCFGR207 (0x010E)	P2_07	GPIO2_07o	GFX0_DISP7			PPG71_PPGB			PPG7_PPGA	GPIO2_07i, EIC0_INT28, FRT17_FRCK, ICU3_IN1
PCFGR208 (0x0110)	P2_08	GPIO2_08o	GFX0_DISP8			PPG0_PPGB	OCU0_OTD0		PPG8_PPGA	GPIO2_08i, EIC0_INT29, FRT18_FRCK, ICU18_IN0

Table 16. Port Multiplexing (Continued)

Register (Offset)	Resource Functional Output									Possible Resource Function Input
	Port	POF=0	POF=1	POF=2	POF=3	POF=4	POF=5	POF=6	POF=7	
PCFGR209 (0x0112)	P2_09	GPIO2_09o	GFX0_DISP9			PPG1_PPGB	OCU0_OTD1		PPG9_PPGB	GPIO2_09i, EIC0_INT30, FRT19_FRCK, ICU18_IN1
PCFGR210 (0x0114)	P2_10	GPIO2_10o	GFX0_DISP10			PPG2_PPGB	OCU1_OTD0		PPG10_PPGB	GPIO2_10i, EIC0_INT31, FRT0_FRCK, ICU19_IN0
PCFGR211 (0x0116)	P2_11	GPIO2_11o	GFX0_DISP11			PPG3_PPGB	OCU1_OTD1		PPG11_PPGB	GPIO2_11i, EIC0_INT14, FRT1_FRCK, ICU19_IN1
PCFGR212 (0x0118)	P2_12	GPIO2_12o	GFX0_DISP12			PPG4_PPGB	OCU16_OTD0		PPG12_PPGB	GPIO2_12i, EIC0_INT15, FRT2_FRCK, ICU2_IN0
PCFGR213 (0x011A)	P2_13	GPIO2_13o	GFX0_DISP13			PPG5_PPGB	OCU16_OTD1		PPG13_PPGB	GPIO2_13i, USART0_SIN, EIC0_INT11, EIC0_INT16, FRT3_FRCK, ICU2_IN1, RLT3_TIN
PCFGR214 (0x011C)	P2_14	GPIO2_14o	GFX0_DISP14		USART0_SCKo		OCU17_OTD0			GPIO2_14i, USART0_SCKi, EIC0_INT17, FRT16_FRCK, ICU3_IN0, RLT4_TIN
PCFGR215 (0x011E)	P2_15	GPIO2_15o	GFX0_DISP15		USART0_SOT		OCU17_OTD1			GPIO2_15i, EIC0_INT18, FRT17_FRCK, ICU3_IN1
PCFGR216 (0x0120)	P2_16	GPIO2_16o	GFX0_DISP16		OCU17_OTD0	PPG6_PPGB			PPG14_PPGB	GPIO2_16i, EIC0_INT19, FRT18_FRCK, ICU3_IN0
PCFGR217 (0x0122)	P2_17	GPIO2_17o	GFX0_DISP17		OCU17_OTD1	PPG7_PPGB			PPG15_PPGB	GPIO2_17i, EIC0_INT20, FRT19_FRCK, ICU3_IN1
PCFGR218 (0x0124)	P2_18	GPIO2_18o	GFX0_DISP18	SPI2_SSo				RLT0_TOT		GPIO2_18i, SPI2_SSi, EIC0_INT21, EIC0_INT05
PCFGR219 (0x0126)	P2_19	GPIO2_19o	GFX0_DISP19	SPI2_DATA1o				RLT1_TOT		GPIO2_19i, SPI2_DATA1i, EIC0_INT22
PCFGR220 (0x0128)	P2_20	GPIO2_20o	GFX0_DISP20	SPI2_DATA0o	OCU0_OTD0	PPG64_PPGB		RLT2_TOT	PPG0_PPGB	GPIO2_20i, SPI2_DATA0i, EIC0_INT23
PCFGR221 (0x012A)	P2_21	GPIO2_21o	GFX0_DISP21	SPI2_CLKo	OCU0_OTD1	PPG65_PPGB		RLT5_TOT	PPG1_PPGB	GPIO2_21i, SPI2_CLKi, EIC0_INT24, RLT2_TIN
PCFGR222 (0x012C)	P2_22	GPIO2_22o	GFX0_DISP22	SPI0_CLKo	OCU1_OTD0	PPG66_PPGB	SPI2_DATA2o		PPG2_PPGB	GPIO2_22i, SPI0_CLKi, SPI2_DATA2i, EIC0_INT25, RLT0_TIN
PCFGR223 (0x012E)	P2_23	GPIO2_23o	GFX0_DISP23	SPI0_DATA1o	OCU1_OTD1	PPG67_PPGB	SPI2_DATA3o	SPI2_SSO3	PPG3_PPGB	GPIO2_23i, SPI0_DATA1i, SPI2_DATA3i, EIC0_INT26, RLT1_TIN
PCFGR224 (0x0130)	P2_24	GPIO2_24o	GFX0_DISP24	SPI0_DATA0o	OCU16_OTD0	PPG68_PPGB	SG0_SGO	SPI2_SSO2	PPG4_PPGB	GPIO2_24i, SPI0_DATA0i, EIC0_INT27, ICU19_IN0, RLT2_TIN
PCFGR225 (0x0132)	P2_25	GPIO2_25o	GFX0_DISP25	SPI0_SSo	OCU16_OTD1	PPG69_PPGB	SG0_SGA	SPI2_SSO1	PPG5_PPGB	GPIO2_25i, SPI0_SSi, EIC0_INT28, EIC0_INT03, ICU19_IN1, RLT5_TIN

Table 16. Port Multiplexing (Continued)

Register (Offset)	Resource Functional Output									Possible Resource Function Input
	Port	POF=0	POF=1	POF=2	POF=3	POF=4	POF=5	POF=6	POF=7	
PCFGR232 (0x0140)	P2_32	GPIO2_32o	SPI2_SS0	UDC0_UDOT0	SPI1_DATA2o	PPG8_PPGB	OCU0_OTD0	RLT9_TOT	PPG0_PPGA	GPIO2_32i, I2S0_ECLK, I2S1_ECLK, SPI1_DATA2i, SPI2_Ss0, SPI0_Ss0, ICU2_IN0, EIC0_INT05, EIC0_INT03, ADC0_EDGI
PCFGR233 (0x0142)	P2_33	GPIO2_33o	SPI2_DATA1o	I2S0_SD0	SPI1_DATA3o	PPG9_PPGB	OCU0_OTD1	RLT8_TOT	PPG1_PPGA	GPIO2_33i, I2S0_Sdi, I2S1_Sdi, SPI1_DATA3i, UDC0_AIN0, SPI2_DATA1i, SPI0_DATA1i, ICU2_IN1, EIC0_INT26, ADC0_AN0
PCFGR234 (0x0144)	P2_34	GPIO2_34o	SPI2_DATA0o	I2S0_WS0	OCU1_OTD1_I	PPG10_PPGB	OCU1_OTD0	RLT7_TOT	PPG2_PPGA	GPIO2_34i, I2S0_WSi, I2S1_WSi, UDC0_BIN0, SPI2_DATA0i, SPI0_DATA0i, ICU3_IN0, EIC0_INT06, EIC0_INT07, ADC0_AN1
PCFGR235 (0x0146)	P2_35	GPIO2_35o	SPI2_CLKo	I2S0_SCKo	OCU1_OTD0_I	PPG11_PPGB	OCU1_OTD1		PPG3_PPGA	GPIO2_35i, I2S0_SCKi, I2S1_SCKi, UDC0_ZIN0, SPI2_CLKi, SPI0_CLKi, RLT2_TIN, ICU3_IN1, EIC0_INT29, ADC0_AN2
PCFGR236 (0x0148)	P2_36	GPIO2_36o	SPI1_SS0	UDC0_UDOT1		PPG12_PPGB	OCU16_OTD0		PPG4_PPGA	GPIO2_36i, I2S1_ECLK, I2S0_ECLK, SPI1_Ss0, SPI2_Ss0, RLT9_TIN, ICU18_IN0, EIC0_INT04, EIC0_INT05, ADC0_AN3
PCFGR237 (0x014A)	P2_37	GPIO2_37o	SPI1_DATA1o	I2S1_SD0		PPG13_PPGB	OCU16_OTD1		PPG5_PPGA	GPIO2_37i, I2S1_SDi, I2S0_SDi, UDC0_AIN1, SPI1_DATA1i, SPI2_DATA1i, RLT8_TIN, ICU18_IN1, EIC0_INT30, ADC0_AN4
PCFGR238 (0x014C)	P2_38	GPIO2_38o	SPI1_DATA0o	I2S1_WS0	OCU17_OTD1_I	PPG14_PPGB	OCU17_OTD0	OCU17_OTD1_GI	PPG6_PPGA	GPIO2_38i, I2S1_WSi, I2S0_WSi, PPG_ETRG0, UDC0_BIN1, SPI1_DATA0i, SPI2_DATA0i, RLT7_TIN, ICU19_IN0, EIC0_INT06, EIC0_INT07, ADC0_AN5
PCFGR239 (0x014E)	P2_39	GPIO2_39o	SPI1_CLKo	I2S1_SCKo	OCU17_OTD0_I	PPG15_PPGB	OCU17_OTD1	OCU17_OTD0_GI	PPG7_PPGA	GPIO2_39i, I2S1_SCKi, I2S0_SCKi, PPG_ETRG1, UDC0_ZIN1, SPI1_CLKi, SPI2_CLKi, RLT1_TIN, ICU19_IN1, EIC0_INT31, ADC0_AN6

Table 16. Port Multiplexing (Continued)

Register (Offset)	Resource Functional Output									Possible Resource Function Input
	Port	POF=0	POF=1	POF=2	POF=3	POF=4	POF=5	POF=6	POF=7	
PCFGR240 (0x0150)	P2_40	GPIO2_40o	SPI0_SSo	reserved	OCU1_OTD1_GI	PPG64_PPGB	OCU0_OTD1_I	RLT8_TOT	PPG8_PPGA	GPIO2_40i, I2S0_ECLK, SPI0_SSi, SPI1_SSi, ICU2_IN0, FRT16_FRCK, CAN1_RX, EIC0_INT03, EIC0_INT04, EIC0_INT10, ADC0_AN7
PCFGR241 (0x0152)	P2_41	GPIO2_41o	SPI0_DATA1o	reserved	OCU1_OTD0_GI	PPG65_PPGB	OCU0_OTD0_I	RLT9_TOT	PPG9_PPGA	GPIO2_41i, I2S0_Sdi, CAN0_RX, CAN1_RX, SPI0_DATA1i, SPI1_DATA1i, RLT8_TIN, ICU2_IN1, FRT17_FRCK, EIC0_INT08, EIC0_INT09, ADC0_AN8
PCFGR242 (0x0154)	P2_42	GPIO2_42o	SPI0_DATA0o	reserved	SG0_SGA	PPG66_PPGB	OCU0_OTD1_GI	OCU16_OTD1_GI	PPG10_PPGA	GPIO2_42i, I2S0_WSi, SPI0_DATA0i, SPI1_DATA0i, RLT9_TIN, ICU3_IN0, FRT18_FRCK, EIC0_INT06, ADC0_AN9
PCFGR243 (0x0156)	P2_43	GPIO2_43o	SPI0_CLKo	reserved	SG0_SGO	PPG67_PPGB	OCU0_OTD0_GI		PPG11_PPGA	GPIO2_43i, I2S0_SCKi, EIC0_NMi, SPI0_CLKi, SPI1_CLKi, RLT0_TIN, ICU3_IN1, FRT19_FRCK, ADC0_AN10
PCFGR248 (0x0160)	P2_48	GPIO2_48o	SG0_SGA	CAN1_TX	USART6_SCKo	PPG68_PPGB	OCU16_OTD1_I	RLT7_TOT	PPG12_PPGA	GPIO2_48i, I2S1_ECLK, RLT6_TIN, CAN0_RX, CAN0_RX, ICU18_IN0, FRT0_FRCK, USART6_SCKi, USART0_SCKi, EIC0_INT08, ADC0_AN11
PCFGR249 (0x0162)	P2_49	GPIO2_49o	SG0_SGO	I2S1_SDo	USART6_SOT	PPG69_PPGB	OCU16_OTD0_I	RLT1_TOT	PPG13_PPGA	GPIO2_49i, I2S1_Sdi, CAN1_RX, FRT0_FRCK, EIC0_INT08, RLT7_TIN, ICU18_IN1, FRT1_FRCK, FRT2_FRCK, FRT3_FRCK, CAN0_RX, EIC0_INT09, ADC0_AN12
PCFGR250 (0x0164)	P2_50	GPIO2_50o	SPI1_DATA0o	SPI0_SSO3	SPI0_DATA3o	PPG2_PPGB	OCU1_OTD0	I2S1_WSo	PPG66_PPGA	GPIO2_50i, EIC0_INT08, RLT5_TIN, I2S1_WSi, EIC0_INT07, SPI0_DATA3i, SPI1_DATA0i, CAN0_RX, EIC0_INT11, ICU3_IN0, EIC0_INT12, FRT2_FRCK, CAN1_RX, UDC0_ZIN1, USART6_SIN, USART0_SIN, EIC0_INT09, ADC0_AN13

Table 16. Port Multiplexing (Continued)

Register (Offset)	Resource Functional Output									Possible Resource Function Input
	Port	POF=0	POF=1	POF=2	POF=3	POF=4	POF=5	POF=6	POF=7	
PCFGR251 (0x0166)	P2_51	GPIO2_51o	SPI1_CLKo	UDC0_UDOT1	CAN0_TX	PPG3_PPGB	OCU1_OTD1	I2S1_SCKo	PPG67_PPGA	GPIO2_51i, EIC0_INT09, FRT2_FRCK, I2S1_SCKi, FRT16_FRCK, FRT17_FRCK, SPI1_CLKi, FRT18_FRCK, CAN1_RX, ICU3_IN1, RLT1_TIN, FRT3_FRCK, FRT19_FRCK, FRT0_FRCK, FRT1_FRCK, ADC0_AN14

Resource Input Source

Table 17. RICFG0_ADC

Register (Offset)	Resource Input	Register Field	Source for Resource Input							
			Bit 0	Bit 1	Bit 2	Bit 3	Bit 4	Bit 5	Bit 6	Bit 7
ADC0EDGI (0x000C)	ADC0_EDGI	ADC0EDGIL	PORTPIN	OCU	-	-	-	-	-	-
			0: Pins selected by PORTSEL registers will be disabled 1: Pins selected by PORTSEL registers will be enabled for ADC0 trigger. All the signals that are enabled by the ADC0ED-GIOCUn registers ANDED together.	reserved	reserved	reserved	reserved	reserved	reserved	
		ADC0EDGIH	PORTSEL	-	-	-	-	-	-	-
			000:reserved 001: reserved 010: P1_30 is selected 011: P1_40 is selected 100:reserved 101: P2_32 is selected 110:reserved 111: reserved	reserved	reserved	reserved	reserved	reserved	reserved	
ADC0EDG-IOCU0 (0x000E)	ADC0_EDGI	ADC0EDG-IOCU0L	OCU00	OCU01	OCU10	OCU11				
			0: OCU0_OTD0 is disabled 1: OCU0_OTD0 is enabled	0: OCU0_OTD1 is disabled 1: OCU0_OTD1 is enabled	0: OCU1_OTD0 is disabled 1: OCU1_OTD0 is enabled	0: OCU1_OTD1 is disabled 1: OCU1_OTD1 is enabled	reserved	reserved	reserved	reserved
		-	-	-	-	-	-	-	-	-
		reserved	reserved	reserved	reserved	reserved	reserved	reserved	reserved	
ADC0EDG-IOCU1 (0x0010)	ADC0_EDGI	-	-	-	-	-	-	-	-	-
			reserved	reserved	reserved	reserved	reserved	reserved	reserved	reserved
		-	-	-	-	-	-	-	-	
		reserved	reserved	reserved	reserved	reserved	reserved	reserved	reserved	
ADC0EDG-IOCU2 (0x0012)	ADC0_EDGI	-	-	-	-	-	-	-	-	-
			reserved	reserved	reserved	reserved	reserved	reserved	reserved	reserved
		-	-	-	-	-	-	-	-	
		reserved	reserved	reserved	reserved	reserved	reserved	reserved	reserved	
ADC0EDG-IOCU3 (0x0014)	ADC0_EDGI	-	-	-	-	-	-	-	-	-
			reserved	reserved	reserved	reserved	reserved	reserved	reserved	reserved
		-	-	-	-	-	-	-	-	
		reserved	reserved	reserved	reserved	reserved	reserved	reserved	reserved	

Note

2. The ADC0ZPDEN register is write-only-once protected.

Table 17. RICFG0_ADC (Continued)

Register (Offset)	Resource Input	Register Field	Source for Resource Input							
			Bit 0	Bit 1	Bit 2	Bit 3	Bit 4	Bit 5	Bit 6	Bit 7
ADC0EDG-IOCU4 (0x0016)	ADC0_EDGI	ADC0EDG-IOCU4L	OCU160	OCU161	OCU170	OCU171				
			0: OCU16_OTD0 is disabled 1: OCU16_OTD0 is enabled	0: OCU16_OTD1 is disabled 1: OCU16_OTD1 is enabled	0: OCU17_OTD0 is disabled 1: OCU17_OTD0 is enabled	0: OCU17_OTD1 is disabled 1: OCU17_OTD1 is enabled	reserved	reserved	reserved	reserved
		-	-	-	-	-	-	-	-	-
		reserved	reserved	reserved	reserved	reserved	reserved	reserved	reserved	
ADC0EDG-IOCU5 (0x0018)	ADC0_EDGI	-	-	-	-	-	-	-	-	-
		reserved	reserved	reserved	reserved	reserved	reserved	reserved	reserved	
		-	-	-	-	-	-	-	-	
		reserved	reserved	reserved	reserved	reserved	reserved	reserved	reserved	
ADC0EDG-IOCU6 (0x001A)	ADC0_EDGI	-	-	-	-	-	-	-	-	-
		reserved	reserved	reserved	reserved	reserved	reserved	reserved	reserved	
		-	-	-	-	-	-	-	-	
		reserved	reserved	reserved	reserved	reserved	reserved	reserved	reserved	
ADC0EDG-IOCU7 (0x001C)	ADC0_EDGI	-	-	-	-	-	-	-	-	-
		reserved	reserved	reserved	reserved	reserved	reserved	reserved	reserved	
		-	-	-	-	-	-	-	-	
		reserved	reserved	reserved	reserved	reserved	reserved	reserved	reserved	
ADC0TIMI (0x001E)	ADC0_TIMI	ADC0TIMIL	RLT	PPGL	PPGH	-	-			
			UFSET output of RLT that is selected by ADC0TIMIRLT bits [3:0] is disabled (0) or enabled (1)	ADTRGH and ADTRGL signals of PPG0 to PPG63 OR-ed together - disabled (0), enabled (1). All the signals for which the corresponding bit is set are OR-ed together, is enabled (2).	All the signals for which the corresponding bit is set are OR-ed together is disabled (0) or enabled (1)	reserved	reserved	reserved	reserved	
		-	-	-	-	-	-	-	-	
		-	-	-	-	-	-	-	-	

Note

2. The ADC0ZPDEN register is write-only-once protected.

Table 17. RICFG0_ADC (Continued)

Register (Offset)	Resource Input	Register Field	Source for Resource Input								
			Bit 0	Bit 1	Bit 2	Bit 3	Bit 4	Bit 5	Bit 6	Bit 7	
ADC0TIMIR LT (0x0020)	ADC0_TIMI	ADC0TIMIR LTL	RLT								
			0000: RLT0_UFSET 0001: RLT1_UFSET ... 1001: RLT9_UFSET 1010 - 1111: reserved								
		-	-	-	-	-	-	-	-	-	
		reserved	reserved	reserved	reserved	reserved	reserved	reserved	reserved	reserved	
ADC0ZPDE N ¹ (0x003E)	ADC0_ZPD	ADC0ZPDIE N	ZPDEN								
			0: ZPD is disabled 1: ZPD is enabled								

Note

2. The ADC0ZPDEN register is write-only-once protected.

Table 18. RICFG0

Register	Resource Input	RESSEL[3:0]/ PORTSEL[3:0]	Source for Resource Input							
			Bit 0	Bit 1	Bit 2	Bit 3	Bit 4	Bit 5	Bit 6	Bit 7
ADC0AN26 (0x0000)	ADC0_AN26	RESSEL (0-7)	-	-	-	-	-	-	-	-
		RESSEL (8-15)	-	-	-	-	-	-	-	-
		PORTSEL (0-7)	P1_00	P1_01	P1_02	P1_03	P1_00/P1_01	P1_01/P1_00	P1_02/P1_03	P1_03/P1_02
		PORTSEL (8-15)	reserved	reserved	reserved	reserved	reserved	reserved	reserved	reserved
ADC0AN27 (0x0002)	ADC0_AN27	RESSEL (0-7)	-	-	-	-	-	-	-	-
		RESSEL (8-15)	-	-	-	-	-	-	-	-
		PORTSEL (0-7)	P1_04	P1_05	P1_06	P1_07	P1_04/ P1_05	P1_05/ P1_04	P1_06/ P1_07	P1_07/ P1_06
		PORTSEL (8-15)	reserved	reserved	reserved	reserved	reserved	reserved	reserved	reserved
ADC0AN28 (0x0004)	ADC0_AN28	RESSEL (0-7)	-	-	-	-	-	-	-	-
		RESSEL (8-15)	-	-	-	-	-	-	-	-
		PORTSEL (0-7)	P1_08	P1_09	P1_10	P1_11	P1_08/ P1_09	P1_09/ P1_08	P1_10/ P1_11	P1_11/ P1_10
		PORTSEL (8-15)	reserved	reserved	reserved	reserved	reserved	reserved	reserved	reserved
ADC0AN29 (0x0006)	ADC0_AN29	RESSEL (0-7)	-	-	-	-	-	-	-	-
		RESSEL (8-15)	-	-	-	-	-	-	-	-
		PORTSEL (0-7)	P1_12	P1_13	P1_14	P1_15	P1_12/ P1_13	P1_13/ P1_12	P1_14/ P1_15	P1_15/ P1_14
		PORTSEL (8-15)	reserved	reserved	reserved	reserved	reserved	reserved	reserved	reserved
ADC0AN30 (0x0008)	ADC0_AN30	RESSEL (0-7)	-	-	-	-	-	-	-	-
		RESSEL (8-15)	-	-	-	-	-	-	-	-
		PORTSEL (0-7)	P1_16	P1_17	P1_18	P1_19	P1_16/ P1_17	P1_17/ P1_16	P1_18/ P1_19	P1_19/ P1_18
		PORTSEL (8-15)	reserved	reserved	reserved	reserved	reserved	reserved	reserved	reserved
ADC0AN31 (0x000A)	ADC0_AN31	RESSEL (0-7)	-	-	-	-	-	-	-	-
		RESSEL (8-15)	-	-	-	-	-	-	-	-
		PORTSEL (0-7)	P1_20	P1_21	P1_22	P1_23	P1_20/ P1_21	P1_21/ P1_20	P1_22/ P1_23	P1_23/ P1_22
		PORTSEL (8-15)	reserved	reserved	reserved	reserved	reserved	reserved	reserved	reserved
ADC0EDGI 0 (0x00C)	ADC0_EDGI	RESSEL (0-7)	-	-	-	-	-	-	-	-
		RESSEL (8-15)	-	-	-	-	-	-	-	-
		PORTSEL (0-7)	reserved	reserved	P1_30	P1_40	reserved	P2_32	reserved	reserved
		PORTSEL (8-15)	reserved	reserved	reserved	reserved	reserved	reserved	reserved	reserved
FRT0TEXT (0x0400)	FRT0_TEXT	RESSEL (0-7)	PORT_PIN	RLT2_TOT	RLT3_TOT	RLT0_TOT	PPG10_PPG B	reserved	reserved	reserved
		RESSEL (8-15)	-	-	-	-	-	-	-	-
		PORTSEL (0-7)	reserved	reserved	reserved	P0_40	P0_47	reserved	reserved	reserved
		PORTSEL (8-15)	P2_48	P2_49	P2_51	P2_02	P2_10	reserved	reserved	reserved

Table 18. RICFG0 (Continued)

Register	Resource Input	RESSEL[3:0]/ PORTSEL[3:0]	Source for Resource Input							
			Bit 0	Bit 1	Bit 2	Bit 3	Bit 4	Bit 5	Bit 6	Bit 7
FRT1TEXT (0x0420)	FRT1_TEXT	RESSEL (0-7)	PORT_PIN	RLT2_TOT	RLT3_TOT	RLT1_TOT	PPG11_PPG B	reserved	reserved	reserved
		RESSEL (8-15)	-	-	-	-	-	-	-	-
		PORTSEL (0-7)	reserved	reserved	P0_41	P0_47	reserved	reserved	P2_49	P2_51
		PORTSEL (8-15)	P2_03	P2_11	reserved	reserved	reserved	reserved	reserved	reserved
FRT2TEXT (0x0440)	FRT2_TEXT	RESSEL (0-7)	PORT_PIN	RLT2_TOT	RLT3_TOT	RLT4_TOT	PPG12_PPG B	reserved	reserved	reserved
		RESSEL (8-15)	-	-	-	-	-	-	-	-
		PORTSEL (0-7)	reserved	reserved	GND	P0_42	P0_47	reserved	reserved	reserved
		PORTSEL (8-15)	P2_49	P2_50	P2_51	P2_04	P2_12	reserved	reserved	reserved
FRT3TEXT (0x0460)	FRT3_TEXT	RESSEL (0-7)	PORT_PIN	RLT2_TOT	RLT3_TOT	RLT5_TOT	PPG13_PPG B	reserved	reserved	reserved
		RESSEL (8-15)	-	-	-	-	-	-	-	-
		PORTSEL (0-7)	reserved	reserved	P0_43	P0_47	reserved	reserved	P2_49	P2_51
		PORTSEL (8-15)	P2_05	P2_13	reserved	reserved	reserved	reserved	reserved	reserved
ICU2IN0 (0x0840)	ICU2_IN0	RESSEL (0-7)	-	-	-	-	-	-	-	-
		RESSEL (8-15)	-	-	-	-	-	-	-	-
		PORTSEL (0-7)	reserved	reserved	reserved	P0_24	reserved	P0_48	P1_35	P1_52
		PORTSEL (8-15)	P0_41	P1_10	P2_32	P2_40	reserved	P1_40	P2_04	P2_12
ICU2IN1 (0x0842)	ICU2_IN1	RESSEL (0-7)	-	-	-	-	-	-	-	-
		RESSEL (8-15)	-	-	-	-	-	-	-	-
		PORTSEL (0-7)	reserved	reserved	reserved	P0_25	reserved	P0_49	P1_36	P1_53
		PORTSEL (8-15)	P0_42	P1_09	P2_33	P2_41	reserved	P1_41	P2_05	P2_13
ICU2FRSEL (0x0844)	ICU2_FRSEL	RESSEL (0-7)	FRT2	FRT0	reserved	reserved	reserved	reserved	reserved	reserved
		RESSEL (8-15)	-	-	-	-	-	-	-	-
		PORTSEL (0-7)	-	-	-	-	-	-	-	-
		PORTSEL (8-15)	-	-	-	-	-	-	-	-
ICU3IN0 (0x0860)	ICU3_IN0	RESSEL (0-7)	-	-	-	-	-	-	-	-
		RESSEL (8-15)	-	-	-	-	-	-	-	-
		PORTSEL (0-7)	reserved	reserved	reserved	reserved	reserved	P1_37	P1_54	P1_32
		PORTSEL (8-15)	P2_34	P2_42	reserved	reserved	P2_50	P2_06	P2_14	P2_16
ICU3IN1 (0x0862)	ICU3_IN1	RESSEL (0-7)	-	-	-	-	-	-	-	-
		RESSEL (8-15)	-	-	-	-	-	-	-	-
		PORTSEL (0-7)	reserved	reserved	reserved	reserved	reserved	P1_38	P1_55	P1_31
		PORTSEL (8-15)	P2_35	P2_43	reserved	reserved	P2_51	P2_07	P2_15	P2_17
ICU2FRSEL (0x0864)	ICU2_FRSEL	RESSEL (0-7)	FRT3	FRT1	ICU2	reserved	reserved	reserved	reserved	reserved
		RESSEL (8-15)	-	-	-	-	-	-	-	-
		PORTSEL (0-7)	-	-	-	-	-	-	-	-
		PORTSEL (8-15)	-	-	-	-	-	-	-	-

Table 18. RICFG0 (Continued)

Register	Resource Input	RESSEL[3:0]/PORTSEL[3:0]	Source for Resource Input							
			Bit 0	Bit 1	Bit 2	Bit 3	Bit 4	Bit 5	Bit 6	Bit 7
OCU00TD0GATE(0x0C00)	OCU0_OTD0GATE	RESSEL (0-7)	RLT4_TOT	RLT0_TOT	PPG5_PPGA	PPG6_PPGA	OCU1_OTD0	OCU1_OTD1	reserved	reserved
		RESSEL (8-15)	-	-	-	-	-	-	-	-
		PORTSEL (0-7)	-	-	-	-	-	-	-	-
		PORTSEL (8-15)	-	-	-	-	-	-	-	-
OCU00TD0GM(0x0C02)	OCU0_OTD0GM	RESSEL (0-7)	SPECIAL0_GND	SPECIAL0_VDD	reserved	reserved	reserved	reserved	reserved	reserved
		RESSEL (8-15)	-	-	-	-	-	-	-	-
		PORTSEL (0-7)	-	-	-	-	-	-	-	-
		PORTSEL (8-15)	-	-	-	-	-	-	-	-
OCU00TD1GATE(0x0C04)	OCU0_OTD1GATE	RESSEL (0-7)	RLT4_TOT	RLT1_TOT	PPG5_PPGA	PPG7_PPGA	OCU1_OTD0	OCU1_OTD1	reserved	reserved
		RESSEL (8-15)	-	-	-	-	-	-	-	-
		PORTSEL (0-7)	-	-	-	-	-	-	-	-
		PORTSEL (8-15)	-	-	-	-	-	-	-	-
OCU00TD1GM(0x0C06)	OCU0_OTD1GM	RESSEL (0-7)	SPECIAL0_GND	SPECIAL0_VDD	reserved	reserved	reserved	reserved	reserved	reserved
		RESSEL (8-15)	-	-	-	-	-	-	-	-
		PORTSEL (0-7)	-	-	-	-	-	-	-	-
		PORTSEL (8-15)	-	-	-	-	-	-	-	-
OCU1CMP0EXT(0x0C20)	OCU1_CMP0EXT	RESSEL (0-7)	OCU1_MTRG	OCU0_CMP0OUT	reserved	reserved	reserved	reserved	reserved	reserved
		RESSEL (8-15)	-	-	-	-	-	-	-	-
		PORTSEL (0-7)	-	-	-	-	-	-	-	-
		PORTSEL (8-15)	-	-	-	-	-	-	-	-
OCU1FRTSEL(0x0C22)	OCU1_FRTSEL	RESSEL (0-7)	FRT1_CNT_EN	FRT0_CNT_EN	reserved	reserved	reserved	reserved	reserved	reserved
		RESSEL (8-15)	-	-	-	-	-	-	-	-
		PORTSEL (0-7)	-	-	-	-	-	-	-	-
		PORTSEL (8-15)	-	-	-	-	-	-	-	-
OCU10TD0GATE(0x0C24)	OCU1_OTD0GATE	RESSEL (0-7)	RLT4_TOT	RLT2_TOT	PPG5_PPGA	PPG8_PPGA	OCU0_OTD0	OCU0_OTD1	reserved	reserved
		RESSEL (8-15)	-	-	-	-	-	-	-	-
		PORTSEL (0-7)	-	-	-	-	-	-	-	-
		PORTSEL (8-15)	-	-	-	-	-	-	-	-
OCU10TD0GM(0x0C26)	OCU1_OTD0GM	RESSEL (0-7)	SPECIAL0_GND	SPECIAL0_VDD	reserved	reserved	reserved	reserved	reserved	reserved
		RESSEL (8-15)	-	-	-	-	-	-	-	-
		PORTSEL (0-7)	-	-	-	-	-	-	-	-
		PORTSEL (8-15)	-	-	-	-	-	-	-	-
OCU10TD1GATE(0x0C28)	OCU1_OTD1GATE	RESSEL (0-7)	RLT4_TOT	RLT3_TOT	PPG5_PPGA	PPG9_PPGA	OCU0_OTD0	OCU0_OTD1	reserved	reserved
		RESSEL (8-15)	-	-	-	-	-	-	-	-
		PORTSEL (0-7)	-	-	-	-	-	-	-	-
		PORTSEL (8-15)	-	-	-	-	-	-	-	-

Table 18. RICFG0 (Continued)

Register	Resource Input	RESSEL[3:0]/PORTSEL[3:0]	Source for Resource Input							
			Bit 0	Bit 1	Bit 2	Bit 3	Bit 4	Bit 5	Bit 6	Bit 7
OCU1OTD1GM(0x0C2A)	OCU1_OTD1GM	RESSEL (0-7)	SPECIAL0_GND	SPECIAL0_VDD	reserved	reserved	reserved	reserved	reserved	reserved
		RESSEL (8-15)	-	-	-	-	-	-	-	-
		PORTSEL (0-7)	-	-	-	-	-	-	-	-
		PORTSEL (8-15)	-	-	-	-	-	-	-	-
USART0SCKI(0x1400)	USART0_SCKI	RESSEL (0-7)	-	-	-	-	-	-	-	-
		RESSEL (8-15)	-	-	-	-	-	-	-	-
		PORTSEL (0-7)	reserved	reserved	P0_41	P0_46	P1_31	P1_44	P1_09	GND
		PORTSEL (8-15)	reserved	P2_48	P2_14	reserved	reserved	reserved	reserved	reserved
USART0SIN(0x1402)	USART0_SIN	RESSEL (0-7)	-	-	-	-	-	-	-	-
		RESSEL (8-15)	-	-	-	-	-	-	-	-
		PORTSEL (0-7)	reserved	reserved	reserved	P0_40	P0_45	P1_30	P1_43	P0_42
		PORTSEL (8-15)	P1_08	reserved	reserved	reserved	P2_50	P2_13	reserved	reserved
PPG0PPGAGATE(0x1C00)	PPG0_PPGAGATE	RESSEL (0-7)	SPECIAL0_VDD	RLT1_TOT	RLT2_TOT	RLT3_TOT	RLT4_TOT	RLT5_TOT	RLT6_TOT	RLT7_TOT
		RESSEL (8-15)	-	-	-	-	-	-	-	-
		PORTSEL (0-7)	-	-	-	-	-	-	-	-
		PORTSEL (8-15)	-	-	-	-	-	-	-	-
PPG0PPGAGM(0x1C02)	PPG0_PPGAGM	RESSEL (0-7)	SPECIAL0_GND	SPECIAL0_VDD	reserved	reserved	reserved	reserved	reserved	reserved
		RESSEL (8-15)	-	-	-	-	-	-	-	-
		PORTSEL (0-7)	-	-	-	-	-	-	-	-
		PORTSEL (8-15)	-	-	-	-	-	-	-	-
PPG0PPGBGATE(0x1C04)	PPG0_PPGBGATE	RESSEL (0-7)	SPECIAL0_VDD	RLT1_TOT	RLT2_TOT	RLT3_TOT	RLT4_TOT	RLT5_TOT	RLT6_TOT	RLT7_TOT
		RESSEL (8-15)	-	-	-	-	-	-	-	-
		PORTSEL (0-7)	-	-	-	-	-	-	-	-
		PORTSEL (8-15)	-	-	-	-	-	-	-	-
PPG0PPGBGM(0x1C06)	PPG0_PPGBGM	RESSEL (0-7)	SPECIAL0_GND	SPECIAL0_VDD	reserved	reserved	reserved	reserved	reserved	reserved
		RESSEL (8-15)	-	-	-	-	-	-	-	-
		PORTSEL (0-7)	-	-	-	-	-	-	-	-
		PORTSEL (8-15)	-	-	-	-	-	-	-	-
PPG1PPGAGATE(0x1C20)	PPG1_PPGAGATE	RESSEL (0-7)	SPECIAL0_VDD	RLT1_TOT	RLT2_TOT	RLT3_TOT	RLT4_TOT	RLT5_TOT	RLT6_TOT	RLT7_TOT
		RESSEL (8-15)	-	-	-	-	-	-	-	-
		PORTSEL (0-7)	-	-	-	-	-	-	-	-
		PORTSEL (8-15)	-	-	-	-	-	-	-	-
PPG1PPGAGM(0x1C22)	PPG1_PPGAGM	RESSEL (0-7)	SPECIAL0_GND	SPECIAL0_VDD	reserved	reserved	reserved	reserved	reserved	reserved
		RESSEL (8-15)	-	-	-	-	-	-	-	-
		PORTSEL (0-7)	-	-	-	-	-	-	-	-
		PORTSEL (8-15)	-	-	-	-	-	-	-	-

Table 18. RICFG0 (Continued)

Register	Resource Input	RESSEL[3:0]/PORTSEL[3:0]	Source for Resource Input							
			Bit 0	Bit 1	Bit 2	Bit 3	Bit 4	Bit 5	Bit 6	Bit 7
PPG1PPGBG ATE(0x1C24)	PPG1_PPG BGATE	RESSEL (0-7)	SPECIAL0_VDD	RLT1_TOT	RLT2_TOT	RLT3_TOT	RLT4_TOT	RLT5_TOT	RLT6_TOT	RLT7_TOT
		RESSEL (8-15)	-	-	-	-	-	-	-	-
		PORTSEL (0-7)	-	-	-	-	-	-	-	-
		PORTSEL (8-15)	-	-	-	-	-	-	-	-
PPG1PPGBG M(0x1C26)	PPG1_PPG BGM	RESSEL (0-7)	SPECIAL0_GND	SPECIAL0_VDD	reserved	reserved	reserved	reserved	reserved	reserved
		RESSEL (8-15)	-	-	-	-	-	-	-	-
		PORTSEL (0-7)	-	-	-	-	-	-	-	-
		PORTSEL (8-15)	-	-	-	-	-	-	-	-
PPG2PPGAG ATE(0x1C40)	PPG2_PPG AGATE	RESSEL (0-7)	SPECIAL0_VDD	RLT1_TOT	RLT2_TOT	RLT3_TOT	RLT4_TOT	RLT5_TOT	RLT6_TOT	RLT7_TOT
		RESSEL (8-15)	-	-	-	-	-	-	-	-
		PORTSEL (0-7)	-	-	-	-	-	-	-	-
		PORTSEL (8-15)	-	-	-	-	-	-	-	-
PPG2PPGAG M(0x1C42)	PPG2_PPG AGM	RESSEL (0-7)	SPECIAL0_GND	SPECIAL0_VDD	reserved	reserved	reserved	reserved	reserved	reserved
		RESSEL (8-15)	-	-	-	-	-	-	-	-
		PORTSEL (0-7)	-	-	-	-	-	-	-	-
		PORTSEL (8-15)	-	-	-	-	-	-	-	-
PPG2PPGBG ATE(0x1C44)	PPG2_PPG BGATE	RESSEL (0-7)	SPECIAL0_VDD	RLT1_TOT	RLT2_TOT	RLT3_TOT	RLT4_TOT	RLT5_TOT	RLT6_TOT	RLT7_TOT
		RESSEL (8-15)	-	-	-	-	-	-	-	-
		PORTSEL (0-7)	-	-	-	-	-	-	-	-
		PORTSEL (8-15)	-	-	-	-	-	-	-	-
PPG2PPGBG M(0x1C46)	PPG2_PPG BGM	RESSEL (0-7)	SPECIAL0_GND	SPECIAL0_VDD	reserved	reserved	reserved	reserved	reserved	reserved
		RESSEL (8-15)	-	-	-	-	-	-	-	-
		PORTSEL (0-7)	-	-	-	-	-	-	-	-
		PORTSEL (8-15)	-	-	-	-	-	-	-	-
PPG3PPGAG ATE(0x1C60)	PPG3_PPG AGATE	RESSEL (0-7)	SPECIAL0_VDD	RLT1_TOT	RLT2_TOT	RLT3_TOT	RLT4_TOT	RLT5_TOT	RLT6_TOT	RLT7_TOT
		RESSEL (8-15)	-	-	-	-	-	-	-	-
		PORTSEL (0-7)	-	-	-	-	-	-	-	-
		PORTSEL (8-15)	-	-	-	-	-	-	-	-
PPG3PPGAG M(0x1C62)	PPG3_PPG AGM	RESSEL (0-7)	SPECIAL0_GND	SPECIAL0_VDD	reserved	reserved	reserved	reserved	reserved	reserved
		RESSEL (8-15)	-	-	-	-	-	-	-	-
		PORTSEL (0-7)	-	-	-	-	-	-	-	-
		PORTSEL (8-15)	-	-	-	-	-	-	-	-

Table 18. RICFG0 (Continued)

Register	Resource Input	RESSEL[3:0]/PORTSEL[3:0]	Source for Resource Input							
			Bit 0	Bit 1	Bit 2	Bit 3	Bit 4	Bit 5	Bit 6	Bit 7
PPG3PPGBG ATE(0x1C64)	PPG3_PPG BGATE	RESSEL (0-7)	SPECIAL0_VDD	RLT1_TOT	RLT2_TOT	RLT3_TOT	RLT4_TOT	RLT5_TOT	RLT6_TOT	RLT7_TOT
		RESSEL (8-15)	-	-	-	-	-	-	-	-
		PORTSEL (0-7)	-	-	-	-	-	-	-	-
		PORTSEL (8-15)	-	-	-	-	-	-	-	-
PPG3PPGBG M(0x1C66)	PPG3_PPG BGM	RESSEL (0-7)	SPECIAL0_GND	SPECIAL0_VDD	reserved	reserved	reserved	reserved	reserved	reserved
		RESSEL (8-15)	-	-	-	-	-	-	-	-
		PORTSEL (0-7)	-	-	-	-	-	-	-	-
		PORTSEL (8-15)	-	-	-	-	-	-	-	-
PPG4PPGAG ATE(0x1C80)	PPG4_PPG AGATE	RESSEL (0-7)	SPECIAL0_VDD	RLT1_TOT	RLT2_TOT	RLT3_TOT	RLT4_TOT	RLT5_TOT	RLT6_TOT	RLT7_TOT
		RESSEL (8-15)	-	-	-	-	-	-	-	-
		PORTSEL (0-7)	-	-	-	-	-	-	-	-
		PORTSEL (8-15)	-	-	-	-	-	-	-	-
PPG4PPGAG M(0x1C82)	PPG4_PPG AGM	RESSEL (0-7)	SPECIAL0_GND	SPECIAL0_VDD	reserved	reserved	reserved	reserved	reserved	reserved
		RESSEL (8-15)	-	-	-	-	-	-	-	-
		PORTSEL (0-7)	-	-	-	-	-	-	-	-
		PORTSEL (8-15)	-	-	-	-	-	-	-	-
PPG4PPGBG ATE(0x1C84)	PPG4_PPG BGATE	RESSEL (0-7)	SPECIAL0_VDD	RLT1_TOT	RLT2_TOT	RLT3_TOT	RLT4_TOT	RLT5_TOT	RLT6_TOT	RLT7_TOT
		RESSEL (8-15)	-	-	-	-	-	-	-	-
		PORTSEL (0-7)	-	-	-	-	-	-	-	-
		PORTSEL (8-15)	-	-	-	-	-	-	-	-
PPG4PPGBG M(0x1C86)	PPG4_PPG BGM	RESSEL (0-7)	SPECIAL0_GND	SPECIAL0_VDD	reserved	reserved	reserved	reserved	reserved	reserved
		RESSEL (8-15)	-	-	-	-	-	-	-	-
		PORTSEL (0-7)	-	-	-	-	-	-	-	-
		PORTSEL (8-15)	-	-	-	-	-	-	-	-
PPG5PPGAG ATE(0x1CA0)	PPG5_PPG AGATE	RESSEL (0-7)	SPECIAL0_VDD	RLT1_TOT	RLT2_TOT	RLT3_TOT	RLT4_TOT	RLT5_TOT	RLT6_TOT	RLT7_TOT
		RESSEL (8-15)	-	-	-	-	-	-	-	-
		PORTSEL (0-7)	-	-	-	-	-	-	-	-
		PORTSEL (8-15)	-	-	-	-	-	-	-	-
PPG5PPGAG M(0x1CA2)	PPG5_PPG AGM	RESSEL (0-7)	SPECIAL0_GND	SPECIAL0_VDD	reserved	reserved	reserved	reserved	reserved	reserved
		RESSEL (8-15)	-	-	-	-	-	-	-	-
		PORTSEL (0-7)	-	-	-	-	-	-	-	-
		PORTSEL (8-15)	-	-	-	-	-	-	-	-

Table 18. RICFG0 (Continued)

Register	Resource Input	RESSEL[3:0]/PORTSEL[3:0]	Source for Resource Input							
			Bit 0	Bit 1	Bit 2	Bit 3	Bit 4	Bit 5	Bit 6	Bit 7
PPG5PPGBG ATE(0x1CA4)	PPG5_PPG BGATE	RESSEL (0-7)	SPECIAL0_VDD	RLT1_TOT	RLT2_TOT	RLT3_TOT	RLT4_TOT	RLT5_TOT	RLT6_TOT	RLT7_TOT
		RESSEL (8-15)	-	-	-	-	-	-	-	-
		PORTSEL (0-7)	-	-	-	-	-	-	-	-
		PORTSEL (8-15)	-	-	-	-	-	-	-	-
PPG5PPGBG M(0x1CA6)	PPG5_PPG BGM	RESSEL (0-7)	SPECIAL0_GND	SPECIAL0_VDD	reserved	reserved	reserved	reserved	reserved	reserved
		RESSEL (8-15)	-	-	-	-	-	-	-	-
		PORTSEL (0-7)	-	-	-	-	-	-	-	-
		PORTSEL (8-15)	-	-	-	-	-	-	-	-
PPG6PPGAG ATE(0x1CC0)	PPG6_PPG AGATE	RESSEL (0-7)	SPECIAL0_VDD	RLT1_TOT	RLT2_TOT	RLT3_TOT	RLT4_TOT	RLT5_TOT	RLT6_TOT	RLT7_TOT
		RESSEL (8-15)	-	-	-	-	-	-	-	-
		PORTSEL (0-7)	-	-	-	-	-	-	-	-
		PORTSEL (8-15)	-	-	-	-	-	-	-	-
PPG6PPGAG M(0x1CC2)	PPG6_PPG AGM	RESSEL (0-7)	SPECIAL0_GND	SPECIAL0_VDD	reserved	reserved	reserved	reserved	reserved	reserved
		RESSEL (8-15)	-	-	-	-	-	-	-	-
		PORTSEL (0-7)	-	-	-	-	-	-	-	-
		PORTSEL (8-15)	-	-	-	-	-	-	-	-
PPG6PPGBG ATE(0x1CC4)	PPG6_PPG BGATE	RESSEL (0-7)	SPECIAL0_VDD	RLT1_TOT	RLT2_TOT	RLT3_TOT	RLT4_TOT	RLT5_TOT	RLT6_TOT	RLT7_TOT
		RESSEL (8-15)	-	-	-	-	-	-	-	-
		PORTSEL (0-7)	-	-	-	-	-	-	-	-
		PORTSEL (8-15)	-	-	-	-	-	-	-	-
PPG6PPGBG M(0x1CC6)	PPG6_PPG BGM	RESSEL (0-7)	SPECIAL0_GND	SPECIAL0_VDD	reserved	reserved	reserved	reserved	reserved	reserved
		RESSEL (8-15)	-	-	-	-	-	-	-	-
		PORTSEL (0-7)	-	-	-	-	-	-	-	-
		PORTSEL (8-15)	-	-	-	-	-	-	-	-
PPG7PPGAG ATE(0x1CE0)	PPG7_PPG AGATE	RESSEL (0-7)	SPECIAL0_VDD	RLT1_TOT	RLT2_TOT	RLT3_TOT	RLT4_TOT	RLT5_TOT	RLT6_TOT	RLT7_TOT
		RESSEL (8-15)	-	-	-	-	-	-	-	-
		PORTSEL (0-7)	-	-	-	-	-	-	-	-
		PORTSEL (8-15)	-	-	-	-	-	-	-	-
PPG7PPGAG M(0x1CE2)	PPG7_PPG AGM	RESSEL (0-7)	SPECIAL0_GND	SPECIAL0_VDD	reserved	reserved	reserved	reserved	reserved	reserved
		RESSEL (8-15)	-	-	-	-	-	-	-	-
		PORTSEL (0-7)	-	-	-	-	-	-	-	-
		PORTSEL (8-15)	-	-	-	-	-	-	-	-

Table 18. RICFG0 (Continued)

Register	Resource Input	RESSEL[3:0]/PORTSEL[3:0]	Source for Resource Input							
			Bit 0	Bit 1	Bit 2	Bit 3	Bit 4	Bit 5	Bit 6	Bit 7
PPG7PPGBG ATE(0x1CE4)	PPG7_PPG BGATE	RESSEL (0-7)	SPECIAL0_VDD	RLT1_TOT	RLT2_TOT	RLT3_TOT	RLT4_TOT	RLT5_TOT	RLT6_TOT	RLT7_TOT
		RESSEL (8-15)	-	-	-	-	-	-	-	-
		PORTSEL (0-7)	-	-	-	-	-	-	-	-
		PORTSEL (8-15)	-	-	-	-	-	-	-	-
PPG7PPGBG M(0x1CE6)	PPG7_PPG BGM	RESSEL (0-7)	SPECIAL0_GND	SPECIAL0_VDD	reserved	reserved	reserved	reserved	reserved	reserved
		RESSEL (8-15)	-	-	-	-	-	-	-	-
		PORTSEL (0-7)	-	-	-	-	-	-	-	-
		PORTSEL (8-15)	-	-	-	-	-	-	-	-
PPG8PPGAG ATE(0x1D00)	PPG8_PPG AGATE	RESSEL (0-7)	SPECIAL0_VDD	RLT1_TOT	RLT2_TOT	RLT3_TOT	RLT4_TOT	RLT5_TOT	RLT6_TOT	RLT7_TOT
		RESSEL (8-15)	-	-	-	-	-	-	-	-
		PORTSEL (0-7)	-	-	-	-	-	-	-	-
		PORTSEL (8-15)	-	-	-	-	-	-	-	-
PPG8PPGAG M(0x1D02)	PPG8_PPG AGM	RESSEL (0-7)	SPECIAL0_GND	SPECIAL0_VDD	reserved	reserved	reserved	reserved	reserved	reserved
		RESSEL (8-15)	-	-	-	-	-	-	-	-
		PORTSEL (0-7)	-	-	-	-	-	-	-	-
		PORTSEL (8-15)	-	-	-	-	-	-	-	-
PPG8PPGBG ATE(0x1D04)	PPG8_PPG BGATE	RESSEL (0-7)	SPECIAL0_VDD	RLT1_TOT	RLT2_TOT	RLT3_TOT	RLT4_TOT	RLT5_TOT	RLT6_TOT	RLT7_TOT
		RESSEL (8-15)	-	-	-	-	-	-	-	-
		PORTSEL (0-7)	-	-	-	-	-	-	-	-
		PORTSEL (8-15)	-	-	-	-	-	-	-	-
PPG8PPGBG M(0x1D06)	PPG8_PPG BGM	RESSEL (0-7)	SPECIAL0_GND	SPECIAL0_VDD	reserved	reserved	reserved	reserved	reserved	reserved
		RESSEL (8-15)	-	-	-	-	-	-	-	-
		PORTSEL (0-7)	-	-	-	-	-	-	-	-
		PORTSEL (8-15)	-	-	-	-	-	-	-	-
PPG9PPGAG ATE(0x1D20)	PPG9_PPG AGATE	RESSEL (0-7)	SPECIAL0_VDD	RLT1_TOT	RLT2_TOT	RLT3_TOT	RLT4_TOT	RLT5_TOT	RLT6_TOT	RLT7_TOT
		RESSEL (8-15)	-	-	-	-	-	-	-	-
		PORTSEL (0-7)	-	-	-	-	-	-	-	-
		PORTSEL (8-15)	-	-	-	-	-	-	-	-
PPG9PPGAG M(0x1D22)	PPG9_PPG AGM	RESSEL (0-7)	SPECIAL0_GND	SPECIAL0_VDD	reserved	reserved	reserved	reserved	reserved	reserved
		RESSEL (8-15)	-	-	-	-	-	-	-	-
		PORTSEL (0-7)	-	-	-	-	-	-	-	-
		PORTSEL (8-15)	-	-	-	-	-	-	-	-

Table 18. RICFG0 (Continued)

Register	Resource Input	RESSEL[3:0]/ PORTSEL[3:0]	Source for Resource Input							
			Bit 0	Bit 1	Bit 2	Bit 3	Bit 4	Bit 5	Bit 6	Bit 7
PPG9PPGBG ATE (0x1D24)	PPG9_PPG BGATE	RESSEL (0-7)	SPECIAL0_ VDD	RLT1_TOT	RLT2_TOT	RLT3_TOT	RLT4_TOT	RLT5_TOT	RLT6_TOT	RLT7_TOT
		RESSEL (8-15)	-	-	-	-	-	-	-	-
		PORTSEL (0-7)	-	-	-	-	-	-	-	-
		PORTSEL (8-15)	-	-	-	-	-	-	-	-
PPG9PPGBG M (0x1D26)	PPG9_PPG BGM	RESSEL (0-7)	SPECIAL0_ GND	SPECIAL0_ VDD	reserved	reserved	reserved	reserved	reserved	reserved
		RESSEL (8-15)	-	-	-	-	-	-	-	-
		PORTSEL (0-7)	-	-	-	-	-	-	-	-
		PORTSEL (8-15)	-	-	-	-	-	-	-	-
PPG10PPGA GATE (0x1D40)	PPG10_PP GAGATE	RESSEL (0-7)	SPECIAL0_ VDD	RLT1_TOT	RLT2_TOT	RLT3_TOT	RLT4_TOT	RLT5_TOT	RLT6_TOT	RLT7_TOT
		RESSEL (8-15)	-	-	-	-	-	-	-	-
		PORTSEL (0-7)	-	-	-	-	-	-	-	-
		PORTSEL (8-15)	-	-	-	-	-	-	-	-
PPG10PPGA GM (0x1D42)	PPG10_PP GAGM	RESSEL (0-7)	SPECIAL0_ GND	SPECIAL0_ VDD	reserved	reserved	reserved	reserved	reserved	reserved
		RESSEL (8-15)	-	-	-	-	-	-	-	-
		PORTSEL (0-7)	-	-	-	-	-	-	-	-
		PORTSEL (8-15)	-	-	-	-	-	-	-	-
PPG10PPGB GATE (0x1D44)	PPG10_PP GBGATE	RESSEL (0-7)	SPECIAL0_ VDD	RLT1_TOT	RLT2_TOT	RLT3_TOT	RLT4_TOT	RLT5_TOT	RLT6_TOT	RLT7_TOT
		RESSEL (8-15)	-	-	-	-	-	-	-	-
		PORTSEL (0-7)	-	-	-	-	-	-	-	-
		PORTSEL (8-15)	-	-	-	-	-	-	-	-
PPG10PPGB GM(0x1D46)	PPG10_PP GBGM	RESSEL (0-7)	SPECIAL0_ GND	SPECIAL0_ VDD	reserved	reserved	reserved	reserved	reserved	reserved
		RESSEL (8-15)	-	-	-	-	-	-	-	-
		PORTSEL (0-7)	-	-	-	-	-	-	-	-
		PORTSEL (8-15)	-	-	-	-	-	-	-	-
PPG11PPGA GATE (0x1D60)	PPG11_PPG AGATE	RESSEL (0-7)	SPECIAL0_ VDD	RLT1_TOT	RLT2_TOT	RLT3_TOT	RLT4_TOT	RLT5_TOT	RLT6_TOT	RLT7_TOT
		RESSEL (8-15)	-	-	-	-	-	-	-	-
		PORTSEL (0-7)	-	-	-	-	-	-	-	-
		PORTSEL (8-15)	-	-	-	-	-	-	-	-
PPG11PPGA GM(0x1D62)	PPG11_PPG AGM	RESSEL (0-7)	SPECIAL0_ GND	SPECIAL0_ VDD	reserved	reserved	reserved	reserved	reserved	reserved
		RESSEL (8-15)	-	-	-	-	-	-	-	-
		PORTSEL (0-7)	-	-	-	-	-	-	-	-
		PORTSEL (8-15)	-	-	-	-	-	-	-	-

Table 18. RICFG0 (Continued)

Register	Resource Input	RESSEL[3:0]/PORTSEL[3:0]	Source for Resource Input							
			Bit 0	Bit 1	Bit 2	Bit 3	Bit 4	Bit 5	Bit 6	Bit 7
PPG11PPGB GATE (0x1D64)	PPG11_PPG BGATE	RESSEL (0-7)	SPECIAL0_VDD	RLT1_TOT	RLT2_TOT	RLT3_TOT	RLT4_TOT	RLT5_TOT	RLT6_TOT	RLT7_TOT
		RESSEL (8-15)	-	-	-	-	-	-	-	-
		PORTSEL (0-7)	-	-	-	-	-	-	-	-
		PORTSEL (8-15)	-	-	-	-	-	-	-	-
PPG11PPGB GM(0x1D66)	PPG11_PPG BGM	RESSEL (0-7)	SPECIAL0_GND	SPECIAL0_VDD	reserved	reserved	reserved	reserved	reserved	reserved
		RESSEL (8-15)	-	-	-	-	-	-	-	-
		PORTSEL (0-7)	-	-	-	-	-	-	-	-
		PORTSEL (8-15)	-	-	-	-	-	-	-	-
PPG12PPGA GATE (0x1D80)	PPG12_PP GAGATE	RESSEL (0-7)	SPECIAL0_VDD	RLT1_TOT	RLT2_TOT	RLT3_TOT	RLT4_TOT	RLT5_TOT	RLT6_TOT	RLT7_TOT
		RESSEL (8-15)	-	-	-	-	-	-	-	-
		PORTSEL (0-7)	-	-	-	-	-	-	-	-
		PORTSEL (8-15)	-	-	-	-	-	-	-	-
PPG12PPGA GM(0x1D82)	PPG12_PP GAGM	RESSEL (0-7)	SPECIAL0_GND	SPECIAL0_VDD	reserved	reserved	reserved	reserved	reserved	reserved
		RESSEL (8-15)	-	-	-	-	-	-	-	-
		PORTSEL (0-7)	-	-	-	-	-	-	-	-
		PORTSEL (8-15)	-	-	-	-	-	-	-	-
PPG12PPGB GATE (0x1D84)	PPG12_PP GBGATE	RESSEL (0-7)	SPECIAL0_VDD	RLT1_TOT	RLT2_TOT	RLT3_TOT	RLT4_TOT	RLT5_TOT	RLT6_TOT	RLT7_TOT
		RESSEL (8-15)	-	-	-	-	-	-	-	-
		PORTSEL (0-7)	-	-	-	-	-	-	-	-
		PORTSEL (8-15)	-	-	-	-	-	-	-	-
PPG12PPGB GM(0x1D86)	PPG12_PP GBGM	RESSEL (0-7)	SPECIAL0_GND	SPECIAL0_VDD	reserved	reserved	reserved	reserved	reserved	reserved
		RESSEL (8-15)	-	-	-	-	-	-	-	-
		PORTSEL (0-7)	-	-	-	-	-	-	-	-
		PORTSEL (8-15)	-	-	-	-	-	-	-	-
PPG13PPGA GATE (0x1DA0)	PPG13_PP GAGATE	RESSEL (0-7)	SPECIAL0_VDD	RLT1_TOT	RLT2_TOT	RLT3_TOT	RLT4_TOT	RLT5_TOT	RLT6_TOT	RLT7_TOT
		RESSEL (8-15)	-	-	-	-	-	-	-	-
		PORTSEL (0-7)	-	-	-	-	-	-	-	-
		PORTSEL (8-15)	-	-	-	-	-	-	-	-
PPG13PPGA GM(0x1DA2)	PPG13_PP GAGM	RESSEL (0-7)	SPECIAL0_GND	SPECIAL0_VDD	reserved	reserved	reserved	reserved	reserved	reserved
		RESSEL (8-15)	-	-	-	-	-	-	-	-
		PORTSEL (0-7)	-	-	-	-	-	-	-	-
		PORTSEL (8-15)	-	-	-	-	-	-	-	-

Table 18. RICFG0 (Continued)

Register	Resource Input	RESSEL[3:0]/PORTSEL[3:0]	Source for Resource Input							
			Bit 0	Bit 1	Bit 2	Bit 3	Bit 4	Bit 5	Bit 6	Bit 7
PPG13PPGB GATE (0x1DA4)	PPG13_PP GBGATE	RESSEL (0-7)	SPECIAL0_VDD	RLT1_TOT	RLT2_TOT	RLT3_TOT	RLT4_TOT	RLT5_TOT	RLT6_TOT	RLT7_TOT
		RESSEL (8-15)	-	-	-	-	-	-	-	-
		PORTSEL (0-7)	-	-	-	-	-	-	-	-
		PORTSEL (8-15)	-	-	-	-	-	-	-	-
PPG13PPGB GM(0x1DA6)	PPG13_PP GBGM	RESSEL (0-7)	SPECIAL0_GND	SPECIAL0_VDD	reserved	reserved	reserved	reserved	reserved	reserved
		RESSEL (8-15)	-	-	-	-	-	-	-	-
		PORTSEL (0-7)	-	-	-	-	-	-	-	-
		PORTSEL (8-15)	-	-	-	-	-	-	-	-
PPG14PPGA GATE (0x1DC0)	PPG14_PP GAGATE	RESSEL (0-7)	SPECIAL0_VDD	RLT1_TOT	RLT2_TOT	RLT3_TOT	RLT4_TOT	RLT5_TOT	RLT6_TOT	RLT7_TOT
		RESSEL (8-15)	-	-	-	-	-	-	-	-
		PORTSEL (0-7)	-	-	-	-	-	-	-	-
		PORTSEL (8-15)	-	-	-	-	-	-	-	-
PPG14PPGA GM(0x1DC2)	PPG14_PP GAGM	RESSEL (0-7)	SPECIAL0_GND	SPECIAL0_VDD	reserved	reserved	reserved	reserved	reserved	reserved
		RESSEL (8-15)	-	-	-	-	-	-	-	-
		PORTSEL (0-7)	-	-	-	-	-	-	-	-
		PORTSEL (8-15)	-	-	-	-	-	-	-	-
PPG14PPGB GATE (0x1DC4)	PPG14_PP GBGATE	RESSEL (0-7)	SPECIAL0_VDD	RLT1_TOT	RLT2_TOT	RLT3_TOT	RLT4_TOT	RLT5_TOT	RLT6_TOT	RLT7_TOT
		RESSEL (8-15)	-	-	-	-	-	-	-	-
		PORTSEL (0-7)	-	-	-	-	-	-	-	-
		PORTSEL (8-15)	-	-	-	-	-	-	-	-
PPG14PPGB GM(0x1DC6)	PPG14_PP GBGM	RESSEL (0-7)	SPECIAL0_GND	SPECIAL0_VDD	reserved	reserved	reserved	reserved	reserved	reserved
		RESSEL (8-15)	-	-	-	-	-	-	-	-
		PORTSEL (0-7)	-	-	-	-	-	-	-	-
		PORTSEL (8-15)	-	-	-	-	-	-	-	-
PPG15PPGA GATE (0x1DE0)	PPG15_PP GAGATE	RESSEL (0-7)	SPECIAL0_VDD	RLT1_TOT	RLT2_TOT	RLT3_TOT	RLT4_TOT	RLT5_TOT	RLT6_TOT	RLT7_TOT
		RESSEL (8-15)	-	-	-	-	-	-	-	-
		PORTSEL (0-7)	-	-	-	-	-	-	-	-
		PORTSEL (8-15)	-	-	-	-	-	-	-	-
PPG15PPGA GM(0x1DE2)	PPG15_PP GAGM	RESSEL (0-7)	SPECIAL0_GND	SPECIAL0_VDD	reserved	reserved	reserved	reserved	reserved	reserved
		RESSEL (8-15)	-	-	-	-	-	-	-	-
		PORTSEL (0-7)	-	-	-	-	-	-	-	-
		PORTSEL (8-15)	-	-	-	-	-	-	-	-

Table 18. RICFG0 (Continued)

Register	Resource Input	RESSEL[3:0]/PORTSEL[3:0]	Source for Resource Input							
			Bit 0	Bit 1	Bit 2	Bit 3	Bit 4	Bit 5	Bit 6	Bit 7
PPG15PPGB GATE (0x1DE4)	PPG15_PP GBGATE	RESSEL (0-7)	SPECIAL0_VDD	RLT1_TOT	RLT2_TOT	RLT3_TOT	RLT4_TOT	RLT5_TOT	RLT6_TOT	RLT7_TOT
		RESSEL (8-15)	-	-	-	-	-	-	-	-
		PORTSEL (0-7)	-	-	-	-	-	-	-	-
		PORTSEL (8-15)	-	-	-	-	-	-	-	-
PPG15PPGB GM(0x1DE6)	PPG15_PP GBGM	RESSEL (0-7)	SPECIAL0_GND	SPECIAL0_VDD	reserved	reserved	reserved	reserved	reserved	reserved
		RESSEL (8-15)	-	-	-	-	-	-	-	-
		PORTSEL (0-7)	-	-	-	-	-	-	-	-
		PORTSEL (8-15)	-	-	-	-	-	-	-	-
PPGGRP0ET RG0(0x2400)	PPGGRP0_ETRG0	RESSEL (0-7)	PORT_PIN	OCU0_OTD0	OCU0_OTD1	OCU1_OTD0	OCU1_OTD1	reserved	reserved	reserved
		RESSEL (8-15)	-	-	-	-	-	-	-	-
		PORTSEL (0-7)	-	-	-	-	-	-	-	-
		PORTSEL (8-15)	-	-	-	-	-	-	-	-
PPGGRP0ET RG1(0x2402)	PPGGRP0_ETRG1	RESSEL (0-7)	PORT_PIN	OCU0_OTD0	OCU0_OTD1	OCU1_OTD0	OCU1_OTD1	reserved	reserved	reserved
		RESSEL (8-15)	-	-	-	-	-	-	-	-
		PORTSEL (0-7)	-	-	-	-	-	-	-	-
		PORTSEL (8-15)	-	-	-	-	-	-	-	-
PPGGRP0ET RG2(0x2404)	PPGGRP0_ETRG2	RESSEL (0-7)	PORT_PIN	OCU16_OTD0	OCU16_OTD1	OCU17_OTD0	OCU17_OTD1	reserved	reserved	reserved
		RESSEL (8-15)	-	-	-	-	-	-	-	-
		PORTSEL (0-7)	-	-	-	-	-	-	-	-
		PORTSEL (8-15)	-	-	-	-	-	-	-	-
PPGGRP0ET RG3(0x2406)	PPGGRP0_ETRG3	RESSEL (0-7)	PORT_PIN	OCU16_OTD0	OCU16_OTD1	OCU17_OTD0	OCU17_OTD1	reserved	reserved	reserved
		RESSEL (8-15)	-	-	-	-	-	-	-	-
		PORTSEL (0-7)	-	-	-	-	-	-	-	-
		PORTSEL (8-15)	-	-	-	-	-	-	-	-
PPGGRP0RL TTRG1 (0x2408)	PPGGRP0_RLTTRG1	RESSEL (0-7)	RLT1_TOT	RLT2_TOT	RLT3_TOT	RLT4_TOT	RLT5_TOT	RLT6_TOT	RLT7_TOT	RLT8_TOT
		RESSEL (8-15)	-	-	-	-	-	-	-	-
		PORTSEL (0-7)	-	-	-	-	-	-	-	-
		PORTSEL (8-15)	-	-	-	-	-	-	-	-
PPGGRP1ET RG0(0x2420)	PPGGRP1_ETRG0	RESSEL (0-7)	PORT_PIN	OCU0_OTD0	OCU0_OTD1	OCU1_OTD0	OCU1_OTD1	reserved	reserved	reserved
		RESSEL (8-15)	-	-	-	-	-	-	-	-
		PORTSEL (0-7)	-	-	-	-	-	-	-	-
		PORTSEL (8-15)	-	-	-	-	-	-	-	-
PPGGRP1ET RG1(0x2422)	PPGGRP1_ETRG1	RESSEL (0-7)	PORT_PIN	OCU0_OTD0	OCU0_OTD1	OCU1_OTD0	OCU1_OTD1	reserved	reserved	reserved
		RESSEL (8-15)	-	-	-	-	-	-	-	-
		PORTSEL (0-7)	-	-	-	-	-	-	-	-
		PORTSEL (8-15)	-	-	-	-	-	-	-	-

Table 18. RICFG0 (Continued)

Register	Resource Input	RESSEL[3:0]/PORTSEL[3:0]	Source for Resource Input							
			Bit 0	Bit 1	Bit 2	Bit 3	Bit 4	Bit 5	Bit 6	Bit 7
PPGGRP1ETRG2(0x2424)	PPGGRP1_ETRG2	RESSEL (0-7)	PORT_PIN	OCU16_OTD0	OCU16_OTD1	OCU17_OTD0	OCU17_OTD1	reserved	reserved	reserved
		RESSEL (8-15)	-	-	-	-	-	-	-	-
		PORTSEL (0-7)	-	-	-	-	-	-	-	-
		PORTSEL (8-15)	-	-	-	-	-	-	-	-
PPGGRP1ETRG3(0x2426)	PPGGRP1_ETRG3	RESSEL (0-7)	PORT_PIN	OCU16_OTD0	OCU16_OTD1	OCU17_OTD0	OCU17_OTD1	reserved	reserved	reserved
		RESSEL (8-15)	-	-	-	-	-	-	-	-
		PORTSEL (0-7)	-	-	-	-	-	-	-	-
		PORTSEL (8-15)	-	-	-	-	-	-	-	-
PPGGRP1RLTTRG1(0x2428)	PPGGRP1_RLTTRG1	RESSEL (0-7)	RLT1_TOT	RLT2_TOT	RLT3_TOT	RLT4_TOT	RLT5_TOT	RLT6_TOT	RLT7_TOT	RLT8_TOT
		RESSEL (8-15)	-	-	-	-	-	-	-	-
		PORTSEL (0-7)	-	-	-	-	-	-	-	-
		PORTSEL (8-15)	-	-	-	-	-	-	-	-
PPGGRP2ETRG0(0x2440)	PPGGRP2_ETRG0	RESSEL (0-7)	PORT_PIN	OCU0_OTD0	OCU0_OTD1	OCU1_OTD0	OCU1_OTD1	reserved	reserved	reserved
		RESSEL (8-15)	-	-	-	-	-	-	-	-
		PORTSEL (0-7)	-	-	-	-	-	-	-	-
		PORTSEL (8-15)	-	-	-	-	-	-	-	-
PPGGRP2ETRG1(0x2442)	PPGGRP2_ETRG1	RESSEL (0-7)	PORT_PIN	OCU0_OTD0	OCU0_OTD1	OCU1_OTD0	OCU1_OTD1	reserved	reserved	reserved
		RESSEL (8-15)	-	-	-	-	-	-	-	-
		PORTSEL (0-7)	-	-	-	-	-	-	-	-
		PORTSEL (8-15)	-	-	-	-	-	-	-	-
PPGGRP2ETRG2(0x2444)	PPGGRP2_ETRG2	RESSEL (0-7)	PORT_PIN	OCU16_OTD0	OCU16_OTD1	OCU17_OTD0	OCU17_OTD1	reserved	reserved	reserved
		RESSEL (8-15)	-	-	-	-	-	-	-	-
		PORTSEL (0-7)	-	-	-	-	-	-	-	-
		PORTSEL (8-15)	-	-	-	-	-	-	-	-
PPGGRP2ETRG3(0x2446)	PPGGRP2_ETRG3	RESSEL (0-7)	PORT_PIN	OCU16_OTD0	OCU16_OTD1	OCU17_OTD0	OCU17_OTD1	reserved	reserved	reserved
		RESSEL (8-15)	-	-	-	-	-	-	-	-
		PORTSEL (0-7)	-	-	-	-	-	-	-	-
		PORTSEL (8-15)	-	-	-	-	-	-	-	-
PPGGRP2RLTTRG1(0x2448)	PPGGRP2_RLTTRG1	RESSEL (0-7)	RLT1_TOT	RLT2_TOT	RLT3_TOT	RLT4_TOT	RLT5_TOT	RLT6_TOT	RLT7_TOT	RLT8_TOT
		RESSEL (8-15)	-	-	-	-	-	-	-	-
		PORTSEL (0-7)	-	-	-	-	-	-	-	-
		PORTSEL (8-15)	-	-	-	-	-	-	-	-
PPGGRP3ETRG0(0x2460)	PPGGRP3_ETRG0	RESSEL (0-7)	PORT_PIN	OCU0_OTD0	OCU0_OTD1	OCU1_OTD0	OCU1_OTD1	reserved	reserved	reserved
		RESSEL (8-15)	-	-	-	-	-	-	-	-
		PORTSEL (0-7)	-	-	-	-	-	-	-	-
		PORTSEL (8-15)	-	-	-	-	-	-	-	-

Table 18. RICFG0 (Continued)

Register	Resource Input	RESSEL[3:0]/ PORTSEL[3:0]	Source for Resource Input							
			Bit 0	Bit 1	Bit 2	Bit 3	Bit 4	Bit 5	Bit 6	Bit 7
PPGGRP3ETRG1(0x2462)	PPGGRP3_ETRG1	RESSEL (0-7)	PORT_PIN	OCU0_OTD0	OCU0_OTD1	OCU1_OTD0	OCU1_OTD1	reserved	reserved	reserved
		RESSEL (8-15)	-	-	-	-	-	-	-	-
		PORTSEL (0-7)	-	-	-	-	-	-	-	-
		PORTSEL (8-15)	-	-	-	-	-	-	-	-
PPGGRP3ETRG2(0x2464)	PPGGRP3_ETRG2	RESSEL (0-7)	PORT_PIN	OCU16_OTD0	OCU16_OTD1	OCU17_OTD0	OCU17_OTD1	reserved	reserved	reserved
		RESSEL (8-15)	-	-	-	-	-	-	-	-
		PORTSEL (0-7)	-	-	-	-	-	-	-	-
		PORTSEL (8-15)	-	-	-	-	-	-	-	-
PPGGRP3ETRG3(0x2466)	PPGGRP3_ETRG3	RESSEL (0-7)	PORT_PIN	OCU16_OTD0	OCU16_OTD1	OCU17_OTD0	OCU17_OTD1	reserved	reserved	reserved
		RESSEL (8-15)	-	-	-	-	-	-	-	-
		PORTSEL (0-7)	-	-	-	-	-	-	-	-
		PORTSEL (8-15)	-	-	-	-	-	-	-	-
PPGGRP3RLTTRG1(0x2468)	PPGGRP3_RLTTRG1	RESSEL (0-7)	RLT1_TOT	RLT2_TOT	RLT3_TOT	RLT4_TOT	RLT5_TOT	RLT6_TOT	RLT7_TOT	RLT8_TOT
		RESSEL (8-15)	-	-	-	-	-	-	-	-
		PORTSEL (0-7)	-	-	-	-	-	-	-	-
		PORTSEL (8-15)	-	-	-	-	-	-	-	-

Table 19. RICFG1

Register	Resource Input	RESSEL[3:0]/ PORTSEL[3:0]	Source for Resource Input								
			Bit 0	Bit 1	Bit 2	Bit 3	Bit 4	Bit 5	Bit 6	Bit 7	
			Bit 8	Bit 9	Bit 10	Bit 11	Bit 12	Bit 13	Bit 14	Bit 15	
CAN0RX (0x0400)	CAN0_RX	RESSEL (0-7)	CAN0_RX	CAN1_RX and CAN1_TX	reserved	reserved	reserved	reserved	reserved	reserved	reserved
		RESSEL (8-15)	-	-	-	-	-	-	-	-	-
		PORTSEL (0-7)	reserved	P0_25	reserved	P0_42	P0_48	reserved	P1_34	P1_00	
		PORTSEL (8-15)	P2_41	reserved	reserved	reserved	P0_49	P2_48	P2_49	P2_50	
CAN1RX (0x0420)	CAN1_RX	RESSEL (0-7)	CAN0_RX	CAN1_RX and CAN1_TX	reserved	reserved	reserved	reserved	reserved	reserved	reserved
		RESSEL (8-15)	-	-	-	-	-	-	-	-	-
		PORTSEL (0-7)	reserved	P0_24	reserved	P0_43	P0_48	reserved	P1_36	P1_02	
		PORTSEL (8-15)	P2_41	reserved	reserved	P0_42	P2_40	P2_49	P2_50	P2_51	
FRT16TEXT (0x0C00)	FRT16_TEXT	RESSEL (0-7)	PORT_PIN	RLT2_TOT	RLT3_TOT	RLT6_TOT	PPG64_PP GB	reserved	reserved	reserved	reserved
		RESSEL (8-15)	-	-	-	-	-	-	-	-	-
		PORTSEL (0-7)	reserved	reserved	P0_44	P0_45	P0_47	P2_40	reserved	P2_51	
		PORTSEL (8-15)	P2_06	P2_14	reserved	reserved	reserved	reserved	reserved	reserved	reserved
FRT17TEXT (0x0C20)	FRT17_TEXT	RESSEL (0-7)	PORT_PIN	RLT2_TOT	RLT3_TOT	RLT7_TOT	PPG65_PP GB	reserved	reserved	reserved	reserved
		RESSEL (8-15)	-	-	-	-	-	-	-	-	-
		PORTSEL (0-7)	reserved	reserved	P0_45	P0_47	P2_41	reserved	P2_51	P2_07	
		PORTSEL (8-15)	P2_15	reserved	reserved	reserved	reserved	reserved	reserved	reserved	reserved
FRT18TEXT (0x0C40)	FRT18_TEXT	RESSEL (0-7)	PORT_PIN	RLT2_TOT	RLT3_TOT	RLT8_TOT	PPG66_PP GB	reserved	reserved	reserved	reserved
		RESSEL (8-15)	-	-	-	-	-	-	-	-	-
		PORTSEL (0-7)	reserved	reserved	P0_45	P0_46	P0_47	P2_42	reserved	P2_51	
		PORTSEL (8-15)	P2_08	P2_16	reserved	reserved	reserved	reserved	reserved	reserved	reserved
FRT19TEXT (0x0C60)	FRT19_TEXT	RESSEL (0-7)	PORT_PIN	RLT2_TOT	RLT3_TOT	RLT9_TOT	PPG67_PP GB	reserved	reserved	reserved	reserved
		RESSEL (8-15)	-	-	-	-	-	-	-	-	-
		PORTSEL (0-7)	reserved	reserved	P0_45	P0_47	P2_43	reserved	P2_51	P2_09	
		PORTSEL (8-15)	P2_17	reserved	reserved	reserved	reserved	reserved	reserved	reserved	reserved
ICU18IN0 (0x1040)	ICU18_IN0	RESSEL (0-7)	-	-	-	-	-	-	-	-	-
		RESSEL (8-15)	-	-	-	-	-	-	-	-	-
		PORTSEL (0-7)	reserved	reserved	reserved	reserved	reserved	P1_43	P1_56	P0_46	
		PORTSEL (8-15)	P1_13	P1_18	P2_36	reserved	reserved	reserved	P2_48	P2_08	
ICU18IN1 (0x1042)	ICU18_IN1	RESSEL (0-7)	-	-	-	-	-	-	-	-	-
		RESSEL (8-15)	-	-	-	-	-	-	-	-	-
		PORTSEL (0-7)	reserved	reserved	reserved	reserved	reserved	P1_44	P1_57	P0_41	
		PORTSEL (8-15)	P0_47	P2_37	reserved	reserved	reserved	P2_49	P2_09	reserved	

Table 19. RICFG1 (Continued)

Register	Resource Input	RESSEL[3:0]/ PORTSEL[3:0]	Source for Resource Input							
			Bit 0	Bit 1	Bit 2	Bit 3	Bit 4	Bit 5	Bit 6	Bit 7
			Bit 8	Bit 9	Bit 10	Bit 11	Bit 12	Bit 13	Bit 14	Bit 15
ICU18FRTSEL (0x1044)	ICU18_FRTSEL	RESSEL (0-7)	FRT18	FRT16	reserved	reserved	reserved	reserved	reserved	reserved
		RESSEL (8-15)	-	-	-	-	-	-	-	-
		PORTSEL (0-7)	-	-	-	-	-	-	-	-
		PORTSEL (8-15)	-	-	-	-	-	-	-	-
ICU19IN0 (0x1060)	ICU19_IN0	RESSEL (0-7)	-	-	-	-	-	-	-	-
		RESSEL (8-15)	-	-	-	-	-	-	-	-
		PORTSEL (0-7)	reserved	reserved	reserved	reserved	reserved	P1_45	P1_58	P0_42
		PORTSEL (8-15)	P2_38	reserved	reserved	reserved	reserved	P2_24	P2_10	reserved
ICU19IN1 (0x1062)	ICU19_IN1	RESSEL (0-7)	-	-	-	-	-	-	-	-
		RESSEL (8-15)	-	-	-	-	-	-	-	-
		PORTSEL (0-7)	reserved	reserved	reserved	reserved	P1_26	P1_46	P1_59	P1_14
		PORTSEL (8-15)	P1_19	P2_39	reserved	reserved	reserved	reserved	P2_25	P2_11
ICU19FRTSEL (0x1064)	ICU19_FRTSEL	RESSEL (0-7)	FRT19	FRT17	ICU18_TOUT0	reserved	reserved	reserved	reserved	reserved
		RESSEL (8-15)	-	-	-	-	-	-	-	-
		PORTSEL (0-7)	-	-	-	-	-	-	-	-
		PORTSEL (8-15)	-	-	-	-	-	-	-	-
OCU16OTD0 GATE (0x1400)	OCU16_OTD0 GATE	RESSEL (0-7)	RLT4_TOT	RLT5_TOT	PPG64_PPGB	PPG65_PPGB	OCU17_OTD0	OCU17_OTD1	reserved	reserved
		RESSEL (8-15)	-	-	-	-	-	-	-	-
		PORTSEL (0-7)	-	-	-	-	-	-	-	-
		PORTSEL (8-15)	-	-	-	-	-	-	-	-
OCU16OTD0 GM (0x1402)	OCU16_OTD0 GM	RESSEL (0-7)	SPECIAL0_GND	SPECIAL0_VDD	reserved	reserved	reserved	reserved	reserved	reserved
		RESSEL (8-15)	-	-	-	-	-	-	-	-
		PORTSEL (0-7)	-	-	-	-	-	-	-	-
		PORTSEL (8-15)	-	-	-	-	-	-	-	-
OCU16OTD0 GM (0x1402)	OCU16_OTD0 GM	RESSEL (0-7)	RLT4_TOT	RLT6_TOT	PPG64_PPGB	PPG66_PPGB	OCU17_OTD0	OCU17_OTD1	reserved	reserved
		RESSEL (8-15)	-	-	-	-	-	-	-	-
		PORTSEL (0-7)	-	-	-	-	-	-	-	-
		PORTSEL (8-15)	-	-	-	-	-	-	-	-
OCU16OTD1 GM (0x1406)	OCU16_OTD1 GM	RESSEL (0-7)	SPECIAL0_GND	SPECIAL0_VDD	reserved	reserved	reserved	reserved	reserved	reserved
		RESSEL (8-15)	-	-	-	-	-	-	-	-
		PORTSEL (0-7)	-	-	-	-	-	-	-	-
		PORTSEL (8-15)	-	-	-	-	-	-	-	-

Table 19. RICFG1 (Continued)

Register	Resource Input	RESSEL[3:0]/ PORTSEL[3:0]	Source for Resource Input								
			Bit 0	Bit 1	Bit 2	Bit 3	Bit 4	Bit 5	Bit 6	Bit 7	
			Bit 8	Bit 9	Bit 10	Bit 11	Bit 12	Bit 13	Bit 14	Bit 15	
OCU17CMP0 EXT (0x1420)	OCU17_CMP0 EXT	RESSEL (0-7)	OCU17_MT RG	OCU16_CM P0OUT	reserved	reserved	reserved	reserved	reserved	reserved	reserved
		RESSEL (8-15)	-	-	-	-	-	-	-	-	-
		PORTSEL (0-7)	-	-	-	-	-	-	-	-	-
		PORTSEL (8-15)	-	-	-	-	-	-	-	-	-
OCU17FRTS EL (0x1422)	OCU17_FRTS EL	RESSEL (0-7)	FRT17_CNT _EN	FRT16_CNT _EN	reserved	reserved	reserved	reserved	reserved	reserved	reserved
		RESSEL (8-15)	-	-	-	-	-	-	-	-	-
		PORTSEL (0-7)	-	-	-	-	-	-	-	-	-
		PORTSEL (8-15)	-	-	-	-	-	-	-	-	-
OCU17OTD0 GATE (0x1424)	OCU17_OTD0 GATE	RESSEL (0-7)	RLT4_TOT	RLT7_TOT	PPG64_PP GB	PPG67_PP GB	OCU16_OT D0	OCU16_OT D1	reserved	reserved	reserved
		RESSEL (8-15)	-	-	-	-	-	-	-	-	-
		PORTSEL (0-7)	-	-	-	-	-	-	-	-	-
		PORTSEL (8-15)	-	-	-	-	-	-	-	-	-
OCU17OTD0 GM (0x1426)	OCU17_OTD0 GM	RESSEL (0-7)	SPECIAL0_ GND	SPECIAL0_ VDD	reserved	reserved	reserved	reserved	reserved	reserved	reserved
		RESSEL (8-15)	-	-	-	-	-	-	-	-	-
		PORTSEL (0-7)	-	-	-	-	-	-	-	-	-
		PORTSEL (8-15)	-	-	-	-	-	-	-	-	-
OCU17OTD1 GATE (0x1428)	OCU17_OTD1 GATE	RESSEL (0-7)	RLT4_TOT	RLT8_TOT	PPG64_PP GB	PPG68_PP GB	OCU16_OT D0	OCU16_OT D1	reserved	reserved	reserved
		RESSEL (8-15)	-	-	-	-	-	-	-	-	-
		PORTSEL (0-7)	-	-	-	-	-	-	-	-	-
		PORTSEL (8-15)	-	-	-	-	-	-	-	-	-
OCU17OTD1 GM (0x142A)	OCU17_OTD1 GM	RESSEL (0-7)	SPECIAL0_ GND	SPECIAL0_ VDD	reserved	reserved	reserved	reserved	reserved	reserved	reserved
		RESSEL (8-15)	-	-	-	-	-	-	-	-	-
		PORTSEL (0-7)	-	-	-	-	-	-	-	-	-
		PORTSEL (8-15)	-	-	-	-	-	-	-	-	-
USART6SCKI (0x1C00)	USART6_SCKI	RESSEL (0-7)	-	-	-	-	-	-	-	-	-
		RESSEL (8-15)	-	-	-	-	-	-	-	-	-
		PORTSEL (0-7)	reserved	reserved	P0_41	P0_46	P1_40	P1_13	reserved	reserved	reserved
		PORTSEL (8-15)	P2_48	reserved	reserved	reserved	reserved	reserved	reserved	reserved	reserved
USART6SIN (0x1C02)	USART6_SIN	RESSEL (0-7)	-	-	-	-	-	-	-	-	-
		RESSEL (8-15)	-	-	-	-	-	-	-	-	-
		PORTSEL (0-7)	reserved	reserved	reserved	P0_40	P0_45	P1_39	P0_47	P1_12	reserved
		PORTSEL (8-15)	reserved	reserved	reserved	P2_50	reserved	reserved	reserved	reserved	reserved

Table 19. RICFG1 (Continued)

Register	Resource Input	RESSEL[3:0]/ PORTSEL[3:0]	Source for Resource Input							
			Bit 0	Bit 1	Bit 2	Bit 3	Bit 4	Bit 5	Bit 6	Bit 7
			Bit 8	Bit 9	Bit 10	Bit 11	Bit 12	Bit 13	Bit 14	Bit 15
PPG64PPGA GATE (0x2400)	PPG64_PPGA GATE	RESSEL (0-7)	SPECIAL0_VDD	RLT1_TOT	RLT2_TOT	RLT3_TOT	RLT4_TOT	RLT5_TOT	RLT6_TOT	RLT7_TOT
		RESSEL (8-15)	-	-	-	-	-	-	-	-
		PORTSEL (0-7)	-	-	-	-	-	-	-	-
		PORTSEL (8-15)	-	-	-	-	-	-	-	-
PPG64PPGA GM (0x2402)	PPG64_PPGA GM	RESSEL (0-7)	SPECIAL0_GND	SPECIAL0_VDD	reserved	reserved	reserved	reserved	reserved	reserved
		RESSEL (8-15)	-	-	-	-	-	-	-	-
		PORTSEL (0-7)	-	-	-	-	-	-	-	-
		PORTSEL (8-15)	-	-	-	-	-	-	-	-
PPG64PPGB GATE (0x2404)	PPG64_PPGB GATE	RESSEL (0-7)	SPECIAL0_VDD	RLT1_TOT	RLT2_TOT	RLT3_TOT	RLT4_TOT	RLT5_TOT	RLT6_TOT	RLT7_TOT
		RESSEL (8-15)	-	-	-	-	-	-	-	-
		PORTSEL (0-7)	-	-	-	-	-	-	-	-
		PORTSEL (8-15)	-	-	-	-	-	-	-	-
PPG64PPGB GM (0x2406)	PPG64_PPGB GM	RESSEL (0-7)	SPECIAL0_GND	SPECIAL0_VDD	reserved	reserved	reserved	reserved	reserved	reserved
		RESSEL (8-15)	-	-	-	-	-	-	-	-
		PORTSEL (0-7)	-	-	-	-	-	-	-	-
		PORTSEL (8-15)	-	-	-	-	-	-	-	-
PPG65PPGA GATE (0x2420)	PPG65_PPGA GATE	RESSEL (0-7)	SPECIAL0_VDD	RLT1_TOT	RLT2_TOT	RLT3_TOT	RLT4_TOT	RLT5_TOT	RLT6_TOT	RLT7_TOT
		RESSEL (8-15)	-	-	-	-	-	-	-	-
		PORTSEL (0-7)	-	-	-	-	-	-	-	-
		PORTSEL (8-15)	-	-	-	-	-	-	-	-
PPG65PPGA GM (0x2422)	PPG65_PPGA GM	RESSEL (0-7)	SPECIAL0_GND	SPECIAL0_VDD	reserved	reserved	reserved	reserved	reserved	reserved
		RESSEL (8-15)	-	-	-	-	-	-	-	-
		PORTSEL (0-7)	-	-	-	-	-	-	-	-
		PORTSEL (8-15)	-	-	-	-	-	-	-	-
PPG65PPGB GATE (0x2424)	PPG65_PPGB GATE	RESSEL (0-7)	SPECIAL0_VDD	RLT1_TOT	RLT2_TOT	RLT3_TOT	RLT4_TOT	RLT5_TOT	RLT6_TOT	RLT7_TOT
		RESSEL (8-15)	-	-	-	-	-	-	-	-
		PORTSEL (0-7)	-	-	-	-	-	-	-	-
		PORTSEL (8-15)	-	-	-	-	-	-	-	-
PPG65PPGB GM (0x2426)	PPG65_PPGB GM	RESSEL (0-7)	SPECIAL0_GND	SPECIAL0_VDD	reserved	reserved	reserved	reserved	reserved	reserved
		RESSEL (8-15)	-	-	-	-	-	-	-	-
		PORTSEL (0-7)	-	-	-	-	-	-	-	-
		PORTSEL (8-15)	-	-	-	-	-	-	-	-

Table 19. RICFG1 (Continued)

Register	Resource Input	RESSEL[3:0]/ PORTSEL[3:0]	Source for Resource Input							
			Bit 0	Bit 1	Bit 2	Bit 3	Bit 4	Bit 5	Bit 6	Bit 7
			Bit 8	Bit 9	Bit 10	Bit 11	Bit 12	Bit 13	Bit 14	Bit 15
PPG66PPGA GATE (0x2440)	PPG66_PPGA GATE	RESSEL (0-7)	SPECIAL0_VDD	RLT1_TOT	RLT2_TOT	RLT3_TOT	RLT4_TOT	RLT5_TOT	RLT6_TOT	RLT7_TOT
		RESSEL (8-15)	-	-	-	-	-	-	-	-
		PORTSEL (0-7)	-	-	-	-	-	-	-	-
		PORTSEL (8-15)	-	-	-	-	-	-	-	-
PPG66PPGA GM (0x2442)	PPG66_PPGA GM	RESSEL (0-7)	SPECIAL0_GND	SPECIAL0_VDD	reserved	reserved	reserved	reserved	reserved	reserved
		RESSEL (8-15)	-	-	-	-	-	-	-	-
		PORTSEL (0-7)	-	-	-	-	-	-	-	-
		PORTSEL (8-15)	-	-	-	-	-	-	-	-
PPG66PPGB GATE (0x2444)	PPG66_PPGB GATE	RESSEL (0-7)	SPECIAL0_VDD	RLT1_TOT	RLT2_TOT	RLT3_TOT	RLT4_TOT	RLT5_TOT	RLT6_TOT	RLT7_TOT
		RESSEL (8-15)	-	-	-	-	-	-	-	-
		PORTSEL (0-7)	-	-	-	-	-	-	-	-
		PORTSEL (8-15)	-	-	-	-	-	-	-	-
PPG66PPGB GM (0x2446)	PPG66_PPGB GM	RESSEL (0-7)	SPECIAL0_GND	SPECIAL0_VDD	reserved	reserved	reserved	reserved	reserved	reserved
		RESSEL (8-15)	-	-	-	-	-	-	-	-
		PORTSEL (0-7)	-	-	-	-	-	-	-	-
		PORTSEL (8-15)	-	-	-	-	-	-	-	-
PPG67PPGA GATE (0x2460)	PPG67_PPGA GATE	RESSEL (0-7)	SPECIAL0_VDD	RLT1_TOT	RLT2_TOT	RLT3_TOT	RLT4_TOT	RLT5_TOT	RLT6_TOT	RLT7_TOT
		RESSEL (8-15)	-	-	-	-	-	-	-	-
		PORTSEL (0-7)	-	-	-	-	-	-	-	-
		PORTSEL (8-15)	-	-	-	-	-	-	-	-
PPG67PPGA GM (0x2462)	PPG67_PPGA GM	RESSEL (0-7)	SPECIAL0_GND	SPECIAL0_VDD	reserved	reserved	reserved	reserved	reserved	reserved
		RESSEL (8-15)	-	-	-	-	-	-	-	-
		PORTSEL (0-7)	-	-	-	-	-	-	-	-
		PORTSEL (8-15)	-	-	-	-	-	-	-	-
PPG67PPGB GATE (0x2464)	PPG67_PPGB GATE	RESSEL (0-7)	SPECIAL0_VDD	RLT1_TOT	RLT2_TOT	RLT3_TOT	RLT4_TOT	RLT5_TOT	RLT6_TOT	RLT7_TOT
		RESSEL (8-15)	-	-	-	-	-	-	-	-
		PORTSEL (0-7)	-	-	-	-	-	-	-	-
		PORTSEL (8-15)	-	-	-	-	-	-	-	-
PPG67PPGB GM (0x2466)	PPG67_PPGB GM	RESSEL (0-7)	SPECIAL0_GND	SPECIAL0_VDD	reserved	reserved	reserved	reserved	reserved	reserved
		RESSEL (8-15)	-	-	-	-	-	-	-	-
		PORTSEL (0-7)	-	-	-	-	-	-	-	-
		PORTSEL (8-15)	-	-	-	-	-	-	-	-

Table 19. RICFG1 (Continued)

Register	Resource Input	RESSEL[3:0]/ PORTSEL[3:0]	Source for Resource Input							
			Bit 0	Bit 1	Bit 2	Bit 3	Bit 4	Bit 5	Bit 6	Bit 7
			Bit 8	Bit 9	Bit 10	Bit 11	Bit 12	Bit 13	Bit 14	Bit 15
PPG68PPGA GATE (0x2480)	PPG68_PPGA GATE	RESSEL (0-7)	SPECIAL0_VDD	RLT1_TOT	RLT2_TOT	RLT3_TOT	RLT4_TOT	RLT5_TOT	RLT6_TOT	RLT7_TOT
		RESSEL (8-15)	-	-	-	-	-	-	-	-
		PORTSEL (0-7)	-	-	-	-	-	-	-	-
		PORTSEL (8-15)	-	-	-	-	-	-	-	-
PPG68PPGA GM (0x2482)	PPG68_PPGA GM	RESSEL (0-7)	SPECIAL0_GND	SPECIAL0_VDD	reserved	reserved	reserved	reserved	reserved	reserved
		RESSEL (8-15)	-	-	-	-	-	-	-	-
		PORTSEL (0-7)	-	-	-	-	-	-	-	-
		PORTSEL (8-15)	-	-	-	-	-	-	-	-
PPG68PPGB GATE (0x2484)	PPG68_PPGB GATE	RESSEL (0-7)	SPECIAL0_VDD	RLT1_TOT	RLT2_TOT	RLT3_TOT	RLT4_TOT	RLT5_TOT	RLT6_TOT	RLT7_TOT
		RESSEL (8-15)	-	-	-	-	-	-	-	-
		PORTSEL (0-7)	-	-	-	-	-	-	-	-
		PORTSEL (8-15)	-	-	-	-	-	-	-	-
PPG68PPGB GM (0x2486)	PPG68_PPGB GM	RESSEL (0-7)	SPECIAL0_GND	SPECIAL0_VDD	reserved	reserved	reserved	reserved	reserved	reserved
		RESSEL (8-15)	-	-	-	-	-	-	-	-
		PORTSEL (0-7)	-	-	-	-	-	-	-	-
		PORTSEL (8-15)	-	-	-	-	-	-	-	-
PPG69PPGA GATE (0x24A0)	PPG69_PPGA GATE	RESSEL (0-7)	SPECIAL0_VDD	RLT1_TOT	RLT2_TOT	RLT3_TOT	RLT4_TOT	RLT5_TOT	RLT6_TOT	RLT7_TOT
		RESSEL (8-15)	-	-	-	-	-	-	-	-
		PORTSEL (0-7)	-	-	-	-	-	-	-	-
		PORTSEL (8-15)	-	-	-	-	-	-	-	-
PPG69PPGA GM (0x24A2)	PPG69_PPGA GM	RESSEL (0-7)	SPECIAL0_GND	SPECIAL0_VDD	reserved	reserved	reserved	reserved	reserved	reserved
		RESSEL (8-15)	-	-	-	-	-	-	-	-
		PORTSEL (0-7)	-	-	-	-	-	-	-	-
		PORTSEL (8-15)	-	-	-	-	-	-	-	-
PPG69PPGB GATE (0x24A4)	PPG69_PPGB GATE	RESSEL (0-7)	SPECIAL0_VDD	RLT1_TOT	RLT2_TOT	RLT3_TOT	RLT4_TOT	RLT5_TOT	RLT6_TOT	RLT7_TOT
		RESSEL (8-15)	-	-	-	-	-	-	-	-
		PORTSEL (0-7)	-	-	-	-	-	-	-	-
		PORTSEL (8-15)	-	-	-	-	-	-	-	-
PPG69PPGB GM (0x24A6)	PPG69_PPGB GM	RESSEL (0-7)	SPECIAL0_GND	SPECIAL0_VDD	reserved	reserved	reserved	reserved	reserved	reserved
		RESSEL (8-15)	-	-	-	-	-	-	-	-
		PORTSEL (0-7)	-	-	-	-	-	-	-	-
		PORTSEL (8-15)	-	-	-	-	-	-	-	-

Table 19. RICFG1 (Continued)

Register	Resource Input	RESSEL[3:0]/ PORTSEL[3:0]	Source for Resource Input							
			Bit 0	Bit 1	Bit 2	Bit 3	Bit 4	Bit 5	Bit 6	Bit 7
			Bit 8	Bit 9	Bit 10	Bit 11	Bit 12	Bit 13	Bit 14	Bit 15
PPG70PPGA GATE (0x24C0)	PPG70_PPGA GATE	RESSEL (0-7)	SPECIAL0_VDD	RLT1_TOT	RLT2_TOT	RLT3_TOT	RLT4_TOT	RLT5_TOT	RLT6_TOT	RLT7_TOT
		RESSEL (8-15)	-	-	-	-	-	-	-	-
		PORTSEL (0-7)	-	-	-	-	-	-	-	-
		PORTSEL (8-15)	-	-	-	-	-	-	-	-
PPG70PPGA GM (0x24C2)	PPG70_PPGA GM	RESSEL (0-7)	SPECIAL0_GND	SPECIAL0_VDD	reserved	reserved	reserved	reserved	reserved	reserved
		RESSEL (8-15)	-	-	-	-	-	-	-	-
		PORTSEL (0-7)	-	-	-	-	-	-	-	-
		PORTSEL (8-15)	-	-	-	-	-	-	-	-
PPG70PPGB GATE (0x24C4)	PPG70_PPGB GATE	RESSEL (0-7)	SPECIAL0_VDD	RLT1_TOT	RLT2_TOT	RLT3_TOT	RLT4_TOT	RLT5_TOT	RLT6_TOT	RLT7_TOT
		RESSEL (8-15)	-	-	-	-	-	-	-	-
		PORTSEL (0-7)	-	-	-	-	-	-	-	-
		PORTSEL (8-15)	-	-	-	-	-	-	-	-
PPG70PPGB GM (0x24C6)	PPG70_PPGB GM	RESSEL (0-7)	SPECIAL0_GND	SPECIAL0_VDD	reserved	reserved	reserved	reserved	reserved	reserved
		RESSEL (8-15)	-	-	-	-	-	-	-	-
		PORTSEL (0-7)	-	-	-	-	-	-	-	-
		PORTSEL (8-15)	-	-	-	-	-	-	-	-
PPG71PPGA GATE (0x24E0)	PPG71_PPGA GATE	RESSEL (0-7)	SPECIAL0_VDD	RLT1_TOT	RLT2_TOT	RLT3_TOT	RLT4_TOT	RLT5_TOT	RLT6_TOT	RLT7_TOT
		RESSEL (8-15)	-	-	-	-	-	-	-	-
		PORTSEL (0-7)	-	-	-	-	-	-	-	-
		PORTSEL (8-15)	-	-	-	-	-	-	-	-
PPG71PPGA GM (0x24E2)	PPG71_PPGA GM	RESSEL (0-7)	SPECIAL0_GND	SPECIAL0_VDD	reserved	reserved	reserved	reserved	reserved	reserved
		RESSEL (8-15)	-	-	-	-	-	-	-	-
		PORTSEL (0-7)	-	-	-	-	-	-	-	-
		PORTSEL (8-15)	-	-	-	-	-	-	-	-
PPG71PPGB GATE (0x24E4)	PPG71_PPGB GATE	RESSEL (0-7)	SPECIAL0_VDD	RLT1_TOT	RLT2_TOT	RLT3_TOT	RLT4_TOT	RLT5_TOT	RLT6_TOT	RLT7_TOT
		RESSEL (8-15)	-	-	-	-	-	-	-	-
		PORTSEL (0-7)	-	-	-	-	-	-	-	-
		PORTSEL (8-15)	-	-	-	-	-	-	-	-
PPG71PPGB GM (0x24E6)	PPG71_PPGB GM	RESSEL (0-7)	SPECIAL0_GND	SPECIAL0_VDD	reserved	reserved	reserved	reserved	reserved	reserved
		RESSEL (8-15)	-	-	-	-	-	-	-	-
		PORTSEL (0-7)	-	-	-	-	-	-	-	-
		PORTSEL (8-15)	-	-	-	-	-	-	-	-

Table 19. RICFG1 (Continued)

Register	Resource Input	RESSEL[3:0]/ PORTSEL[3:0]	Source for Resource Input							
			Bit 0	Bit 1	Bit 2	Bit 3	Bit 4	Bit 5	Bit 6	Bit 7
			Bit 8	Bit 9	Bit 10	Bit 11	Bit 12	Bit 13	Bit 14	Bit 15
PPGGRP16E TRG0 (0x2C00)	PPGGRP16_E TRG0	RESSEL (0-7)	PORT_PIN	OCU0_OTD 0	OCU0_OTD 1	OCU1_OTD 0	OCU1_OTD 1	reserved	reserved	reserved
		RESSEL (8-15)	-	-	-	-	-	-	-	-
		PORTSEL (0-7)	-	-	-	-	-	-	-	-
		PORTSEL (8-15)	-	-	-	-	-	-	-	-
PPGGRP16E TRG1 (0x2C02)	PPGGRP16_E TRG1	RESSEL (0-7)	PORT_PIN	OCU0_OTD 0	OCU0_OTD 1	OCU1_OTD 0	OCU1_OTD 1	reserved	reserved	reserved
		RESSEL (8-15)	-	-	-	-	-	-	-	-
		PORTSEL (0-7)	-	-	-	-	-	-	-	-
		PORTSEL (8-15)	-	-	-	-	-	-	-	-
PPGGRP16E TRG2 (0x2C04)	PPGGRP16_E TRG2	RESSEL (0-7)	PORT_PIN	OCU16_OT D0	OCU16_OT D1	OCU17_OT D0	OCU17_OT D1	reserved	reserved	reserved
		RESSEL (8-15)	-	-	-	-	-	-	-	-
		PORTSEL (0-7)	-	-	-	-	-	-	-	-
		PORTSEL (8-15)	-	-	-	-	-	-	-	-
PPGGRP16E TRG3 (0x2C06)	PPGGRP16_E TRG3	RESSEL (0-7)	PORT_PIN	OCU16_OT D0	OCU16_OT D1	OCU17_OT D0	OCU17_OT D1	reserved	reserved	reserved
		RESSEL (8-15)	-	-	-	-	-	-	-	-
		PORTSEL (0-7)	-	-	-	-	-	-	-	-
		PORTSEL (8-15)	-	-	-	-	-	-	-	-
PPGGRP16R LTTRG1 (0x2C08)	PPGGRP16_R LTTRG1	RESSEL (0-7)	RLT1_TOT	RLT2_TOT	RLT3_TOT	RLT4_TOT	RLT5_TOT	RLT6_TOT	RLT7_TOT	RLT8_TOT
		RESSEL (8-15)	-	-	-	-	-	-	-	-
		PORTSEL (0-7)	-	-	-	-	-	-	-	-
		PORTSEL (8-15)	-	-	-	-	-	-	-	-
PPGGRP17E TRG0 (0x2C20)	PPGGRP17_E TRG0	RESSEL (0-7)	PORT_PIN	OCU0_OTD 0	OCU0_OTD 1	OCU1_OTD 0	OCU1_OTD 1	reserved	reserved	reserved
		RESSEL (8-15)	-	-	-	-	-	-	-	-
		PORTSEL (0-7)	-	-	-	-	-	-	-	-
		PORTSEL (8-15)	-	-	-	-	-	-	-	-
PPGGRP17E TRG1 (0x2C22)	PPGGRP17_E TRG1	RESSEL (0-7)	PORT_PIN	OCU0_OTD 0	OCU0_OTD 1	OCU1_OTD 0	OCU1_OTD 1	reserved	reserved	reserved
		RESSEL (8-15)	-	-	-	-	-	-	-	-
		PORTSEL (0-7)	-	-	-	-	-	-	-	-
		PORTSEL (8-15)	-	-	-	-	-	-	-	-
PPGGRP17E TRG2 (0x2C24)	PPGGRP17_E TRG2	RESSEL (0-7)	PORT_PIN	OCU16_OT D0	OCU16_OT D1	OCU17_OT D0	OCU17_OT D1	reserved	reserved	reserved
		RESSEL (8-15)	-	-	-	-	-	-	-	-
		PORTSEL (0-7)	-	-	-	-	-	-	-	-
		PORTSEL (8-15)	-	-	-	-	-	-	-	-

Table 19. RICFG1 (Continued)

Register	Resource Input	RESSEL[3:0]/ PORTSEL[3:0]	Source for Resource Input							
			Bit 0	Bit 1	Bit 2	Bit 3	Bit 4	Bit 5	Bit 6	Bit 7
			Bit 8	Bit 9	Bit 10	Bit 11	Bit 12	Bit 13	Bit 14	Bit 15
PPGGRP17E TRG3 (0x2C26)	PPGGRP17_E TRG3	RESSEL (0-7)	PORT_PIN	OCU16_OT D0	OCU16_OT D1	OCU17_OT D0	OCU17_OT D1	reserved	reserved	reserved
		RESSEL (8-15)	-	-	-	-	-	-	-	-
		PORTSEL (0-7)	-	-	-	-	-	-	-	-
		PORTSEL (8-15)	-	-	-	-	-	-	-	-
PPGGRP17R LTTRG1 (0x2C28)	PPGGRP17_R LTTRG1	RESSEL (0-7)	RLT1_TOT	RLT2_TOT	RLT3_TOT	RLT4_TOT	RLT5_TOT	RLT6_TOT	RLT7_TOT	RLT8_TOT
		RESSEL (8-15)	-	-	-	-	-	-	-	-
		PORTSEL (0-7)	-	-	-	-	-	-	-	-
		PORTSEL (8-15)	-	-	-	-	-	-	-	-

Table 20. RICFG3

Register	Resource Input	RESSEL[3:0] PORTSEL[3:0]	Source for Resource Input								
			Bit 0	Bit 1	Bit 2	Bit 3	Bit 4	Bit 5	Bit 6	Bit 7	
			Bit 8	Bit 9	Bit 10	Bit 11	Bit 12	Bit 13	Bit 14	Bit 15	
RLT0TIN (0x0800)	RLT0_TIN	RESSEL (0-7)	PORT_PIN	RLT9_TOT	RLT9_UFSET	RLT1_TOT	PPG0_PPGA	SPECIAL0_M CLKDIV4	SPECIAL0_R CCLKDIV4	-	
		RESSEL (8-15)	reserved	reserved	reserved	reserved	reserved	reserved	reserved	reserved	
		PORTSEL (0-7)	reserved	P0_47	P2_22	P1_11	P2_43	reserved	reserved	reserved	
		PORTSEL (8-15)	reserved	reserved	reserved	reserved	reserved	reserved	reserved	reserved	
RLT1TIN (0x0820)	RLT1_TIN	RESSEL (0-7)	PORT_PIN	RLT0_TOT	RLT0_UFSET	RLT2_TOT	PPG1_PPGA	SPECIAL0_M CLKDIV4	SPECIAL0_R CCLKDIV4	-	
		RESSEL (8-15)	reserved	reserved	reserved	reserved	reserved	reserved	reserved	reserved	
		PORTSEL (0-7)	reserved	reserved	P2_23	P1_15	P2_39	reserved	P2_51	reserved	
		PORTSEL (8-15)	reserved	reserved	reserved	reserved	reserved	reserved	reserved	reserved	
RLT2TIN (0x0840)	RLT2_TIN	RESSEL (0-7)	PORT_PIN	RLT1_TOT	RLT1_UFSET	RLT3_TOT	PPG2_PPGA	SPECIAL0_M CLKDIV4	SPECIAL0_R CCLKDIV4	-	
		RESSEL (8-15)	reserved	reserved	reserved	reserved	reserved	reserved	reserved	reserved	
		PORTSEL (0-7)	reserved	P0_43	P2_24	P1_19	P2_35	reserved	P2_21	reserved	
		PORTSEL (8-15)	reserved	reserved	reserved	reserved	reserved	reserved	reserved	reserved	
RLT3TIN (0x0860)	RLT3_TIN	RESSEL (0-7)	PORT_PIN	RLT2_TOT	RLT2_UFSET	RLT4_TOT	PPG3_PPGA	SPECIAL0_M CLKDIV4	SPECIAL0_R CCLKDIV4	-	
		RESSEL (8-15)	reserved	reserved	reserved	reserved	reserved	reserved	reserved	reserved	
		PORTSEL (0-7)	reserved	P0_45	P1_30	P1_43	P1_08	reserved	P2_13	reserved	
		PORTSEL (8-15)	reserved	reserved	reserved	reserved	reserved	reserved	reserved	reserved	
RLT4TIN (0x0880)	RLT4_TIN	RESSEL (0-7)	PORT_PIN	RLT3_TOT	RLT3_UFSET	RLT5_TOT	PPG4_PPGA	USART0_SO T	USART6_SOT	-	
		RESSEL (8-15)	reserved	reserved	reserved	reserved	reserved	reserved	reserved	reserved	
		PORTSEL (0-7)	reserved	P0_46	P1_31	P1_44	P1_09	reserved	P2_14	reserved	
		PORTSEL (8-15)	reserved	reserved	reserved	reserved	reserved	reserved	reserved	reserved	
RLT5TIN (0x08A0)	RLT5_TIN	RESSEL (0-7)	PORT_PIN	RLT4_TOT	RLT4_UFSET	RLT6_TOT	PPG5_PPGA	USART0_SO T	USART6_SOT	-	
		RESSEL (8-15)	reserved	reserved	reserved	reserved	reserved	reserved	reserved	reserved	
		PORTSEL (0-7)	reserved	P0_40	P1_39	P2_25	P1_12	reserved	reserved	P2_50	
		PORTSEL (8-15)	reserved	reserved	reserved	reserved	reserved	reserved	reserved	reserved	
RLT6TIN (0x08C0)	RLT6_TIN	RESSEL (0-7)	PORT_PIN	RLT5_TOT	RLT5_UFSET	RLT7_TOT	PPG6_PPGA	UDC0_UDOT 0	UDC0_UDOT 1	-	
		RESSEL (8-15)	reserved	reserved	reserved	reserved	reserved	reserved	reserved	reserved	
		PORTSEL (0-7)	reserved	P0_41	P1_40	P1_13	reserved	P2_48	reserved	reserved	
		PORTSEL (8-15)	reserved	reserved	reserved	reserved	reserved	reserved	reserved	reserved	
RLT7TIN (0x08E0)	RLT7_TIN	RESSEL (0-7)	PORT_PIN	RLT6_TOT	RLT6_UFSET	RLT8_TOT	PPG7_PPGA	UDC0_UDOT 0	UDC0_UDOT 1	-	
		RESSEL (8-15)	reserved	reserved	reserved	reserved	reserved	reserved	reserved	reserved	
		PORTSEL (0-7)	reserved	reserved	reserved	P2_38	reserved	P2_49	reserved	reserved	
		PORTSEL (8-15)	reserved	reserved	reserved	reserved	reserved	reserved	reserved	reserved	

Table 20. RICFG3 (Continued)

Register	Resource Input	RESSEL[3:0] PORTSEL[3:0]	Source for Resource Input							
			Bit 0	Bit 1	Bit 2	Bit 3	Bit 4	Bit 5	Bit 6	Bit 7
			Bit 8	Bit 9	Bit 10	Bit 11	Bit 12	Bit 13	Bit 14	Bit 15
RLT8TIN (0x0900)	RLT8_TIN	RESSEL (0-7)	PORT_PIN	RLT7_TOT	RLT7_UFSET	RLT9_TOT	PPG8_PPGA	UDC0_UDOT 0	UDC0_UDOT 1	-
		RESSEL (8-15)	reserved	reserved	reserved	reserved	reserved	reserved	reserved	reserved
		PORTSEL (0-7)	reserved	reserved	reserved	P2_37	P2_41	reserved	reserved	reserved
		PORTSEL (8-15)	reserved	reserved	reserved	reserved	reserved	reserved	reserved	reserved
RLT9TIN (0x0920)	RLT9_TIN	RESSEL (0-7)	PORT_PIN	RLT8_TOT	RLT8_UFSET	RLT0_TOT	PPG9_PPGA	UDC0_UDOT 0	UDC0_UDOT 1	-
		RESSEL (8-15)	reserved	reserved	reserved	reserved	reserved	reserved	reserved	reserved
		PORTSEL (0-7)	reserved	reserved	reserved	P2_36	P2_42	reserved	reserved	reserved
		PORTSEL (8-15)	reserved	reserved	reserved	reserved	reserved	reserved	reserved	reserved
UDC0AIN0 (0x1000)	UDC0_AIN0	RESSEL (0-7)	PORT_PIN	RLT0_TOT	RLT3_TOT	RLT7_TOT	-	-	-	-
		RESSEL (8-15)	reserved	reserved	reserved	reserved	reserved	reserved	reserved	reserved
		PORTSEL (0-7)	reserved	reserved	P1_34	P1_53	P0_44	P2_33	reserved	reserved
		PORTSEL (8-15)	reserved	reserved	reserved	reserved	reserved	reserved	reserved	reserved
UDC0AIN1 (0x1004)	UDC0_AIN1	RESSEL (0-7)	PORT_PIN	RLT1_TOT	RLT4_TOT	RLT7_TOT	-	-	-	-
		RESSEL (8-15)	reserved	reserved	reserved	reserved	reserved	reserved	reserved	reserved
		PORTSEL (0-7)	reserved	reserved	P1_43	P1_57	P0_48	P2_37	reserved	reserved
		PORTSEL (8-15)	reserved	reserved	reserved	reserved	reserved	reserved	reserved	reserved
UDC0BIN0 (0x1008)	UDC0_BIN0	RESSEL (0-7)	PORT_PIN	RLT1_TOT	RLT4_TOT	RLT8_TOT	-	-	-	-
		RESSEL (8-15)	reserved	reserved	reserved	reserved	reserved	reserved	reserved	reserved
		PORTSEL (0-7)	reserved	reserved	P1_35	P1_54	P0_45	P2_34	reserved	reserved
		PORTSEL (8-15)	reserved	reserved	reserved	reserved	reserved	reserved	reserved	reserved
UDC0BIN1 (0x100C)	UDC0_BIN1	RESSEL (0-7)	PORT_PIN	RLT2_TOT	RLT5_TOT	RLT8_TOT	-	-	-	-
		RESSEL (8-15)	reserved	reserved	reserved	reserved	reserved	reserved	reserved	reserved
		PORTSEL (0-7)	reserved	reserved	P1_44	P1_58	P0_49	P2_38	reserved	reserved
		PORTSEL (8-15)	reserved	reserved	reserved	reserved	reserved	reserved	reserved	reserved
UDC0ZIN0 (0x1010)	UDC0_ZIN0	RESSEL (0-7)	PORT_PIN	RLT2_TOT	RLT5_TOT	RLT9_TOT	PPG0_PPGA	PPG1_PPGA	PPG2_PPGA	PPG3_PP GA
		RESSEL (8-15)	reserved	reserved	reserved	reserved	reserved	reserved	reserved	reserved
		PORTSEL (0-7)	reserved	reserved	P1_36	P1_55	P0_46	P2_35	reserved	reserved
		PORTSEL (8-15)	reserved	reserved	reserved	reserved	reserved	reserved	reserved	reserved
UDC0ZIN1 (0x1014)	UDC0_ZIN1	RESSEL (0-7)	PORT_PIN	RLT3_TOT	RLT6_TOT	RLT9_TOT	PPG0_PPGA	PPG1_PPGA	PPG2_PPGA	PPG3_PP GA
		RESSEL (8-15)	reserved	reserved	reserved	reserved	reserved	reserved	reserved	reserved
		PORTSEL (0-7)	reserved	reserved	P1_45	P1_59	reserved	P2_39	reserved	reserved
		PORTSEL (8-15)	reserved	P2_50	reserved	reserved	reserved	reserved	reserved	reserved

Table 21. RICFG4

Register	Resource Input	RESSEL[3:0] /PORT-SEL[3:0]	Source for Resource Input								
			Bit 0	Bit 1	Bit 2	Bit 3	Bit 4	Bit 5	Bit 6	Bit 7	
			Bit 8	Bit 9	Bit 10	Bit 11	Bit 12	Bit 13	Bit 14	Bit 15	
I2S0ECLK (0x1000)	I2S0_ECLK	RESSEL (0-7)	PORT_PIN	SPECIAL0_C LK_PERI1	-	-	-	-	-	-	-
		RESSEL (8-15)	reserved	reserved	reserved	reserved	reserved	reserved	reserved	reserved	reserved
		PORTSEL (0-7)	reserved	reserved	reserved	reserved	P2_32	P2_36	P2_40	reserved	reserved
		PORTSEL (8-15)	reserved	reserved	reserved	reserved	reserved	reserved	reserved	reserved	reserved
I2S0SCKI (0x1004)	I2S0_SCKi	RESSEL (0-7)	-	-	-	-	-	-	-	-	-
		RESSEL (8-15)	-	-	-	-	-	-	-	-	-
		PORTSEL (0-7)	reserved	reserved	reserved	P2_35	P2_39	P2_43	reserved	reserved	reserved
		PORTSEL (8-15)	reserved	reserved	reserved	reserved	reserved	reserved	reserved	reserved	reserved
I2S0SDI (0x1008)	I2S0_SDi	RESSEL (0-7)	-	-	-	-	-	-	-	-	-
		RESSEL (8-15)	-	-	-	-	-	-	-	-	-
		PORTSEL (0-7)	reserved	reserved	reserved	P2_33	P2_37	P2_41	reserved	reserved	reserved
		PORTSEL (8-15)	reserved	reserved	reserved	reserved	reserved	reserved	reserved	reserved	reserved
I2S0WSI (0x100C)	I2S0_WSi	RESSEL (0-7)	-	-	-	-	-	-	-	-	-
		RESSEL (8-15)	-	-	-	-	-	-	-	-	-
		PORTSEL (0-7)	reserved	reserved	reserved	P2_34	P2_38	P2_42	reserved	reserved	reserved
		PORTSEL (8-15)	reserved	reserved	reserved	reserved	reserved	reserved	reserved	reserved	reserved
I2S1ECLK (0x1020)	I2S1_ECLK	RESSEL (0-7)	PORT_PIN	SPECIAL0_C LK_PERI1	-	-	-	-	-	-	-
		RESSEL (8-15)	reserved	reserved	reserved	reserved	reserved	reserved	reserved	reserved	reserved
		PORTSEL (0-7)	reserved	reserved	reserved	reserved	P2_32	P2_36	reserved	reserved	reserved
		PORTSEL (8-15)	P2_48	reserved	reserved	reserved	reserved	reserved	reserved	reserved	reserved
I2S1SCKI (0x1024)	I2S1_SCKi	RESSEL (0-7)	-	-	-	-	-	-	-	-	-
		RESSEL (8-15)	-	-	-	-	-	-	-	-	-
		PORTSEL (0-7)	reserved	reserved	P1_27	P2_35	P2_39	reserved	reserved	reserved	P2_51
		PORTSEL (8-15)	reserved	reserved	reserved	reserved	reserved	reserved	reserved	reserved	reserved
I2S1SDI (0x1028)	I2S1_SDi	RESSEL (0-7)	-	-	-	-	-	-	-	-	-
		RESSEL (8-15)	-	-	-	-	-	-	-	-	-

Table 21. RICFG4 (Continued)

Register	Resource Input	RESSEL[3:0] /PORT- SEL[3:0]	Source for Resource Input							
			Bit 0	Bit 1	Bit 2	Bit 3	Bit 4	Bit 5	Bit 6	Bit 7
			Bit 8	Bit 9	Bit 10	Bit 11	Bit 12	Bit 13	Bit 14	Bit 15
I2S1SDI (0x1028)	I2S1_SDi	PORTSEL (0-7)	reserved	reserved	reserved	P2_33	P2_37	reserved	reserved	P2_49
		PORTSEL (8-15)	reserved	reserved	reserved	reserved	reserved	reserved	reserved	reserved
I2S1WSI (0x102C)	I2S1_WSi	RESSEL (0-7)	-	-	-	-	-	-	-	-
		RESSEL (8-15)	-	-	-	-	-	-	-	-
		PORTSEL (0-7)	reserved	reserved	P1_26	P2_34	P2_38	reserved	reserved	P2_50
		PORTSEL (8-15)	reserved	reserved	reserved	reserved	reserved	reserved	reserved	reserved
SPI0CLKI (0x1C00)	SPI0_CLKi	RESSEL (0-7)	-	-	-	-	-	-	-	-
		RESSEL (8-15)	-	-	-	-	-	-	-	-
		PORTSEL (0-7)	reserved	reserved	P0_47	P1_11	P2_35	P2_43	reserved	P2_22
		PORTSEL (8-15)	reserved	reserved	reserved	reserved	reserved	reserved	reserved	reserved
SPI0DATA0I (0x1C04)	SPI0_DATA0i	RESSEL (0-7)	-	-	-	-	-	-	-	-
		RESSEL (8-15)	-	-	-	-	-	-	-	-
		PORTSEL (0-7)	reserved	reserved	P0_46	P1_10	P2_34	P2_42	reserved	P2_24
		PORTSEL (8-15)	reserved	reserved	reserved	reserved	reserved	reserved	reserved	reserved
SPI0DATA1I (0x1C08)	SPI0_DATA1i	RESSEL (0-7)	-	-	-	-	-	-	-	-
		RESSEL (8-15)	-	-	-	-	-	-	-	-
		PORTSEL (0-7)	reserved	reserved	P0_45	P1_09	P2_33	P2_41	reserved	P2_23
		PORTSEL (8-15)	reserved	reserved	reserved	reserved	reserved	reserved	reserved	reserved
SPI0SSI (0x1C0C)	SPI0_SSi	RESSEL (0-7)	-	-	-	-	-	-	-	-
		RESSEL (8-15)	-	-	-	-	-	-	-	-
		PORTSEL (0-7)	reserved	reserved	P0_44	P1_08	P2_32	P2_40	reserved	P2_25
		PORTSEL (8-15)	reserved	reserved	reserved	reserved	reserved	reserved	reserved	reserved
SPI1CLKI (0x1C20)	SPI1_CLKi	RESSEL (0-7)	-	-	-	-	-	-	-	-
		RESSEL (8-15)	-	-	-	-	-	-	-	-
		PORTSEL (0-7)	reserved	reserved	reserved	P1_15	P2_39	P2_43	reserved	P2_51
		PORTSEL (8-15)	reserved	reserved	reserved	reserved	reserved	reserved	reserved	reserved
SPI1DATA0I (0x1C24)	SPI1_DATA0i	RESSEL (0-7)	-	-	-	-	-	-	-	

Table 21. RICFG4 (Continued)

Register	Resource Input	RESSEL[3:0] /PORT-SEL[3:0]	Source for Resource Input								
			Bit 0	Bit 1	Bit 2	Bit 3	Bit 4	Bit 5	Bit 6	Bit 7	
			Bit 8	Bit 9	Bit 10	Bit 11	Bit 12	Bit 13	Bit 14	Bit 15	
SPI1DATA0I (0x1C24)	SPI1_DATA0i	RESSEL (8-15)	-	-	-	-	-	-	-	-	-
		PORTSEL (0-7)	reserved	reserved	reserved	P1_14	P2_38	P2_42	reserved	P2_50	
		PORTSEL (8-15)	reserved	reserved	reserved	reserved	reserved	reserved	reserved	reserved	
SPI1DATA1I (0x1C28)	SPI1_DATA1i	RESSEL (0-7)	-	-	-	-	-	-	-	-	-
		RESSEL (8-15)	-	-	-	-	-	-	-	-	-
		PORTSEL (0-7)	reserved	reserved	P0_49	P1_13	P2_37	P2_41	reserved	reserved	
		PORTSEL (8-15)	reserved	reserved	reserved	reserved	reserved	reserved	reserved	reserved	
SPI1SSI (0x1C2C)	SPI1_SSi	RESSEL (0-7)	-	-	-	-	-	-	-	-	-
		RESSEL (8-15)	-	-	-	-	-	-	-	-	-
		PORTSEL (0-7)	reserved	reserved	P0_48	P1_12	P2_36	P2_40	reserved	reserved	
		PORTSEL (8-15)	reserved	reserved	reserved	reserved	reserved	reserved	reserved	reserved	
SPI2CLKI (0x1C40)	SPI2_CLKi	RESSEL (0-7)	-	-	-	-	-	-	-	-	-
		RESSEL (8-15)	-	-	-	-	-	-	-	-	-
		PORTSEL (0-7)	reserved	reserved	P0_43	P1_19	P2_35	P2_39	reserved	P2_21	
		PORTSEL (8-15)	reserved	reserved	reserved	reserved	reserved	reserved	reserved	reserved	
SPI2DATA0I (0x1C44)	SPI2_DATA0i	RESSEL (0-7)	-	-	-	-	-	-	-	-	-
		RESSEL (8-15)	-	-	-	-	-	-	-	-	-
		PORTSEL (0-7)	reserved	reserved	P0_42	P1_18	P2_34	P2_38	reserved	P2_20	
		PORTSEL (8-15)	reserved	reserved	reserved	reserved	reserved	reserved	reserved	reserved	
SPI2DATA1I (0x1C48)	SPI2_DATA1i	RESSEL (0-7)	-	-	-	-	-	-	-	-	-
		RESSEL (8-15)	-	-	-	-	-	-	-	-	-
		PORTSEL (0-7)	reserved	reserved	P0_41	P1_17	P2_33	P2_37	reserved	P2_19	
		PORTSEL (8-15)	reserved	reserved	reserved	reserved	reserved	reserved	reserved	reserved	
SPI2DATA2I (0x1C4C)	SPI2_DATA2i	RESSEL (0-7)	-	-	-	-	-	-	-	-	-
		RESSEL (8-15)	-	-	-	-	-	-	-	-	-
		PORTSEL (0-7)	reserved	reserved	reserved	P2_22	reserved	reserved	reserved	reserved	
		PORTSEL (8-15)	reserved	reserved	reserved	reserved	reserved	reserved	reserved	reserved	

Table 21. RICFG4 (Continued)

Register	Resource Input	RESSEL[3:0] /PORTSEL[3:0]	Source for Resource Input								
			Bit 0	Bit 1	Bit 2	Bit 3	Bit 4	Bit 5	Bit 6	Bit 7	
			Bit 8	Bit 9	Bit 10	Bit 11	Bit 12	Bit 13	Bit 14	Bit 15	
SPI2DATA3I (0x1C50)	SPI2_DATA3i	RESSEL (0-7)	-	-	-	-	-	-	-	-	-
		RESSEL (8-15)	-	-	-	-	-	-	-	-	-
		PORTSEL (0-7)	reserved	P0_45	reserved	P2_23	reserved	reserved	reserved	reserved	reserved
		PORTSEL (8-15)	reserved	reserved	reserved	reserved	reserved	reserved	reserved	reserved	reserved
SPI2SSI (0x1C58)	SPI2_SSi	RESSEL (0-7)	-	-	-	-	-	-	-	-	-
		RESSEL (8-15)	-	-	-	-	-	-	-	-	-
		PORTSEL (0-7)	reserved	reserved	P0_40	P1_16	P2_32	P2_36	reserved	reserved	P2_18
		PORTSEL (8-15)	reserved	reserved	reserved	reserved	reserved	reserved	reserved	reserved	reserved

Table 22. RICFG7

Register	Resource Input	RESSEL[3:0]/PORTSEL[3:0]	Source for Resource Input								
			Bit 0	Bit 1	Bit 2	Bit 3	Bit 4	Bit 5	Bit 6	Bit 7	
			Bit 8	Bit 9	Bit 10	Bit 11	Bit 12	Bit 13	Bit 14	Bit 15	
GFX0DCLKI (0x0000)	GFX0_DCLKI	RESSEL (0-7)	-	-	-	-	-	-	-	-	-
		RESSEL (8-15)	-	-	-	-	-	-	-	-	-
		PORTSEL (0-7)	reserved	P1_30	P1_39	reserved	reserved	reserved	reserved	reserved	reserved
		PORTSEL (8-15)	reserved	reserved	reserved	reserved	reserved	reserved	reserved	reserved	reserved
EIC0INT00 (0x1000)	EIC0_INT00	RESSEL (0-7)	-	-	-	-	-	-	-	-	-
		RESSEL (8-15)	-	-	-	-	-	-	-	-	-
		PORTSEL (0-7)	reserved	P1_47	P0_63	P1_08	reserved	P1_60	reserved	reserved	reserved
		PORTSEL (8-15)	reserved	reserved	reserved	reserved	reserved	reserved	reserved	reserved	reserved
EIC0INT01 (0x1004)	EIC0_INT01	RESSEL (0-7)	-	-	-	-	-	-	-	-	-
		RESSEL (8-15)	-	-	-	-	-	-	-	-	-
		PORTSEL (0-7)	reserved	P1_33	P1_48	P1_09	reserved	P1_61	reserved	reserved	reserved
		PORTSEL (8-15)	reserved	reserved	reserved	reserved	reserved	reserved	reserved	reserved	reserved
EIC0INT02 (0x1008)	EIC0_INT02	RESSEL (0-7)	-	-	-	-	-	-	-	-	-
		RESSEL (8-15)	-	-	-	-	-	-	-	-	-
		PORTSEL (0-7)	reserved	P1_42	P1_49	P1_10	reserved	reserved	P1_62	reserved	reserved
		PORTSEL (8-15)	reserved	reserved	reserved	reserved	reserved	reserved	reserved	reserved	reserved
EIC0INT03 (0x100C)	EIC0_INT03	RESSEL (0-7)	-	-	-	-	-	-	-	-	-
		RESSEL (8-15)	-	-	-	-	-	-	-	-	-
		PORTSEL (0-7)	reserved	reserved	P0_44	P1_11	P1_08	P2_32	P2_40	reserved	reserved
		PORTSEL (8-15)	P2_25	reserved	reserved	reserved	reserved	reserved	reserved	reserved	reserved
EIC0INT04 (0x1010)	EIC0_INT04	RESSEL (0-7)	-	-	-	-	-	-	-	-	-
		RESSEL (8-15)	-	-	-	-	-	-	-	-	-
		PORTSEL (0-7)	reserved	reserved	P0_48	P1_12	P2_36	P2_40	reserved	reserved	reserved
		PORTSEL (8-15)	reserved	reserved	reserved	reserved	reserved	reserved	reserved	reserved	reserved
EIC0INT05 (0x1014)	EIC0_INT05	RESSEL (0-7)	-	-	-	-	-	-	-	-	-
		RESSEL (8-15)	-	-	-	-	-	-	-	-	-
		PORTSEL (0-7)	reserved	reserved	P0_40	P1_13	P1_16	P2_32	P2_36	reserved	reserved
		PORTSEL (8-15)	P2_18	reserved	reserved	reserved	reserved	reserved	reserved	reserved	reserved
EIC0INT06 (0x1018)	EIC0_INT06	RESSEL (0-7)	-	-	-	-	-	-	-	-	-
		RESSEL (8-15)	-	-	-	-	-	-	-	-	-
		PORTSEL (0-7)	reserved	reserved	reserved	P1_14	P2_34	P2_38	P2_42	reserved	reserved
		PORTSEL (8-15)	reserved	reserved	reserved	reserved	reserved	reserved	reserved	reserved	reserved
EIC0INT07 (0x101C)	EIC0_INT07	RESSEL (0-7)	-	-	-	-	-	-	-	-	-
		RESSEL (8-15)	-	-	-	-	-	-	-	-	-
		PORTSEL (0-7)	reserved	reserved	P1_26	P1_15	P2_34	P2_38	reserved	reserved	reserved
		PORTSEL (8-15)	P2_50	reserved	reserved	reserved	reserved	reserved	reserved	reserved	reserved

Table 22. RICFG7 (Continued)

Register	Resource Input	RESSEL[3:0]/PORTSEL[3:0]	Source for Resource Input							
			Bit 0	Bit 1	Bit 2	Bit 3	Bit 4	Bit 5	Bit 6	Bit 7
			Bit 8	Bit 9	Bit 10	Bit 11	Bit 12	Bit 13	Bit 14	Bit 15
EIC0INT08 (0x1020)	EIC0_INT08	RESSEL (0-7)	-	-	-	-	-	-	-	-
		RESSEL (8-15)	-	-	-	-	-	-	-	-
		PORTSEL (0-7)	reserved	P0_25	reserved	P0_42	P0_48	reserved	P1_34	P1_00
		PORTSEL (8-15)	P2_41	reserved	reserved	P2_48	P2_49	P2_50	reserved	reserved
EIC0INT09 (0x1024)	EIC0_INT09	RESSEL (0-7)	-	-	-	-	-	-	-	-
		RESSEL (8-15)	-	-	-	-	-	-	-	-
		PORTSEL (0-7)	reserved	P0_24	reserved	P0_43	P0_48	reserved	P1_36	P1_02
		PORTSEL (8-15)	P2_41	reserved	reserved	P2_49	P2_50	P2_51	reserved	reserved
EIC0INT10 (0x1028)	EIC0_INT10	RESSEL (0-7)	-	-	-	-	-	-	-	-
		RESSEL (8-15)	-	-	-	-	-	-	-	-
		PORTSEL (0-7)	reserved	P0_24	reserved	P0_42	P0_49	reserved	P1_38	P1_16
		PORTSEL (8-15)	P2_40	reserved	reserved	reserved	reserved	reserved	reserved	reserved
EIC0INT11 (0x102C)	EIC0_INT11	RESSEL (0-7)	-	-	-	-	-	-	-	-
		RESSEL (8-15)	-	-	-	-	-	-	-	-
		PORTSEL (0-7)	reserved	reserved	reserved	P0_40	P0_45	P1_30	P1_43	P0_42
		PORTSEL (8-15)	P1_08	reserved	reserved	reserved	P2_50	P2_13	reserved	reserved
EIC0INT12 (0x1030)	EIC0_INT12	RESSEL (0-7)	-	-	-	-	-	-	-	-
		RESSEL (8-15)	-	-	-	-	-	-	-	-
		PORTSEL (0-7)	reserved	reserved	reserved	P0_40	P0_45	P1_39	P0_47	P1_12
		PORTSEL (8-15)	reserved	reserved	reserved	P2_50	reserved	reserved	reserved	reserved
EIC0INT13 (0x1034)	EIC0_INT13	RESSEL (0-7)	-	-	-	-	-	-	-	-
		RESSEL (8-15)	-	-	-	-	-	-	-	-
		PORTSEL (0-7)	reserved	P1_37	P1_02	P1_16	reserved	reserved	reserved	reserved
		PORTSEL (8-15)	reserved	reserved	reserved	reserved	reserved	reserved	reserved	reserved
EIC0INT14 (0x1038)	EIC0_INT14	RESSEL (0-7)	-	-	-	-	-	-	-	-
		RESSEL (8-15)	-	-	-	-	-	-	-	-
		PORTSEL (0-7)	reserved	reserved	P1_50	P1_17	P2_11	reserved	reserved	reserved
		PORTSEL (8-15)	reserved	reserved	reserved	reserved	reserved	reserved	reserved	reserved
EIC0INT15 (0x103C)	EIC0_INT15	RESSEL (0-7)	-	-	-	-	-	-	-	-
		RESSEL (8-15)	-	-	-	-	-	-	-	-
		PORTSEL (0-7)	reserved	P0_41	P1_51	P1_18	P2_12	reserved	reserved	reserved
		PORTSEL (8-15)	reserved	reserved	reserved	reserved	reserved	reserved	reserved	reserved
EIC0INT16 (0x1040)	EIC0_INT16	RESSEL (0-7)	-	-	-	-	-	-	-	-
		RESSEL (8-15)	-	-	-	-	-	-	-	-
		PORTSEL (0-7)	reserved	P0_46	P1_52	P1_19	P2_13	reserved	reserved	reserved
		PORTSEL (8-15)	reserved	reserved	reserved	reserved	reserved	reserved	reserved	reserved

Table 22. RICFG7 (Continued)

Register	Resource Input	RESSEL[3:0]/PORTSEL[3:0]	Source for Resource Input							
			Bit 0	Bit 1	Bit 2	Bit 3	Bit 4	Bit 5	Bit 6	Bit 7
			Bit 8	Bit 9	Bit 10	Bit 11	Bit 12	Bit 13	Bit 14	Bit 15
EIC0INT17 (0x1044)	EIC0_INT17	RESSEL (0-7)	-	-	-	-	-	-	-	-
		RESSEL (8-15)	-	-	-	-	-	-	-	-
		PORTSEL (0-7)	reserved	P0_47	P1_53	P1_20	P2_14	reserved	reserved	reserved
		PORTSEL (8-15)	reserved	reserved	reserved	reserved	reserved	reserved	reserved	reserved
EIC0INT18 (0x1048)	EIC0_INT18	RESSEL (0-7)	-	-	-	-	-	-	-	-
		RESSEL (8-15)	-	-	-	-	-	-	-	-
		PORTSEL (0-7)	reserved	reserved	P1_54	P1_21	P2_15	reserved	reserved	reserved
		PORTSEL (8-15)	reserved	reserved	reserved	reserved	reserved	reserved	reserved	reserved
EIC0INT19 (0x104C)	EIC0_INT19	RESSEL (0-7)	-	-	-	-	-	-	-	-
		RESSEL (8-15)	-	-	-	-	-	-	-	-
		PORTSEL (0-7)	reserved	reserved	P1_55	P1_22	P2_16	reserved	reserved	reserved
		PORTSEL (8-15)	reserved	reserved	reserved	reserved	reserved	reserved	reserved	reserved
EIC0INT20 (0x1050)	EIC0_INT20	RESSEL (0-7)	-	-	-	-	-	-	-	-
		RESSEL (8-15)	-	-	-	-	-	-	-	-
		PORTSEL (0-7)	reserved	reserved	P1_56	P1_23	P2_17	reserved	reserved	reserved
		PORTSEL (8-15)	reserved	reserved	reserved	reserved	reserved	reserved	reserved	reserved
EIC0INT21 (0x1054)	EIC0_INT21	RESSEL (0-7)	-	-	-	-	-	-	-	-
		RESSEL (8-15)	-	-	-	-	-	-	-	-
		PORTSEL (0-7)	reserved	P1_27	P1_57	P2_00	P2_18	reserved	reserved	reserved
		PORTSEL (8-15)	reserved	reserved	reserved	reserved	reserved	reserved	reserved	reserved
EIC0INT22 (0x1058)	EIC0_INT22	RESSEL (0-7)	-	-	-	-	-	-	-	-
		RESSEL (8-15)	-	-	-	-	-	-	-	-
		PORTSEL (0-7)	reserved	P1_28	P1_58	P2_01	P2_19	reserved	reserved	reserved
		PORTSEL (8-15)	reserved	reserved	reserved	reserved	reserved	reserved	reserved	reserved
EIC0INT23 (0x105C)	EIC0_INT23	RESSEL (0-7)	-	-	-	-	-	-	-	-
		RESSEL (8-15)	-	-	-	-	-	-	-	-
		PORTSEL (0-7)	reserved	P1_29	P1_59	P2_02	P2_20	reserved	reserved	reserved
		PORTSEL (8-15)	reserved	reserved	reserved	reserved	reserved	reserved	reserved	reserved
EIC0INT24 (0x1060)	EIC0_INT24	RESSEL (0-7)	-	-	-	-	-	-	-	-
		RESSEL (8-15)	-	-	-	-	-	-	-	-
		PORTSEL (0-7)	reserved	P1_31	P0_62	P2_03	P2_21	reserved	reserved	reserved
		PORTSEL (8-15)	reserved	reserved	reserved	reserved	reserved	reserved	reserved	reserved
EIC0INT25 (0x1064)	EIC0_INT25	RESSEL (0-7)	-	-	-	-	-	-	-	-
		RESSEL (8-15)	-	-	-	-	-	-	-	-
		PORTSEL (0-7)	reserved	P1_32	P1_00	P2_04	P2_22	reserved	reserved	reserved
		PORTSEL (8-15)	reserved	reserved	reserved	reserved	reserved	reserved	reserved	reserved

Table 22. RICFG7 (Continued)

Register	Resource Input	RESSEL[3:0]/PORTSEL[3:0]	Source for Resource Input								
			Bit 0	Bit 1	Bit 2	Bit 3	Bit 4	Bit 5	Bit 6	Bit 7	
			Bit 8	Bit 9	Bit 10	Bit 11	Bit 12	Bit 13	Bit 14	Bit 15	
EIC0INT26 (0x1068)	EIC0_INT26	RESSEL (0-7)	-	-	-	-	-	-	-	-	-
		RESSEL (8-15)	-	-	-	-	-	-	-	-	-
		PORTSEL (0-7)	reserved	P1_35	P1_01	P2_05	P2_23	P2_33	reserved	reserved	reserved
		PORTSEL (8-15)	reserved	reserved	reserved	reserved	reserved	reserved	reserved	reserved	reserved
EIC0INT27 (0x106C)	EIC0_INT27	RESSEL (0-7)	-	-	-	-	-	-	-	-	-
		RESSEL (8-15)	-	-	-	-	-	-	-	-	-
		PORTSEL (0-7)	reserved	P1_40	P1_03	P2_06	P2_24	reserved	reserved	reserved	reserved
		PORTSEL (8-15)	reserved	reserved	reserved	reserved	reserved	reserved	reserved	reserved	reserved
EIC0INT28 (0x1070)	EIC0_INT28	RESSEL (0-7)	-	-	-	-	-	-	-	-	-
		RESSEL (8-15)	-	-	-	-	-	-	-	-	-
		PORTSEL (0-7)	reserved	P1_41	P1_04	P2_07	P2_25	reserved	reserved	reserved	reserved
		PORTSEL (8-15)	reserved	reserved	reserved	reserved	reserved	reserved	reserved	reserved	reserved
EIC0INT29 (0x1074)	EIC0_INT29	RESSEL (0-7)	-	-	-	-	-	-	-	-	-
		RESSEL (8-15)	-	-	-	-	-	-	-	-	-
		PORTSEL (0-7)	reserved	P1_44	P1_05	P2_08	P2_35	reserved	reserved	reserved	reserved
		PORTSEL (8-15)	reserved	reserved	reserved	reserved	reserved	reserved	reserved	reserved	reserved
EIC0INT30 (0x1078)	EIC0_INT30	RESSEL (0-7)	-	-	-	-	-	-	-	-	-
		RESSEL (8-15)	-	-	-	-	-	-	-	-	-
		PORTSEL (0-7)	reserved	P1_45	P1_06	P2_09	P2_37	reserved	reserved	reserved	reserved
		PORTSEL (8-15)	reserved	reserved	reserved	reserved	reserved	reserved	reserved	reserved	reserved
EIC0INT31 (0x107C)	EIC0_INT31	RESSEL (0-7)	-	-	-	-	-	-	-	-	-
		RESSEL (8-15)	-	-	-	-	-	-	-	-	-
		PORTSEL (0-7)	reserved	P1_46	P1_07	P2_10	P2_39	reserved	reserved	reserved	reserved
		PORTSEL (8-15)	reserved	reserved	reserved	reserved	reserved	reserved	reserved	reserved	reserved
EIC0NMI (0x1080)	EIC0_NMI	RESSEL (0-7)	-	-	-	-	-	-	-	-	-
		RESSEL (8-15)	-	-	-	-	-	-	-	-	-
		PORTSEL (0-7)	reserved	P2_43	reserved	reserved	reserved	reserved	reserved	reserved	reserved
		PORTSEL (8-15)	reserved	reserved	reserved	reserved	reserved	reserved	reserved	reserved	reserved

Table 23. RICFG8

Register	Resource Input	RESSEL[3:0]/ PORTSEL[3:0]	Source for Resource Input							
			Bit 0	Bit 1	Bit 2	Bit 3	Bit 4	Bit 5	Bit 6	Bit 7
			Bit 8	Bit 9	Bit 10	Bit 11	Bit 12	Bit 13	Bit 14	Bit 15
HSSPI0MS TART (0x0000)	HSSPI0_MSTAR T	RESSEL (0-7)	RLT0_TOT	RLT3_TOT	RLT6_TOT	RLT9_TOT	PPG64_PPGB	OCU16_OTD0	reserved	reserved
		RESSEL (8-15)	-	-	-	-	-	-	-	-
		PORTSEL (0-7)	-	-	-	-	-	-	-	-
		PORTSEL (8-15)	-	-	-	-	-	-	-	-

I/O Pin Types

Table 24. Pin Circuit Type of QFP-176

Pin Number	IO_TYPE
1	MODE
2	X1
3	X0
4	VSS50
5	X0A
6	X1A
7	MODE
8	VDD50
9	VSS50
10	VDD33
11	BIDI33
12	BIDI33
13	BIDI33
14	BIDI33
15	BIDI33
16	BIDI33
17	BIDI33
18	BIDI33
19	BIDI33
20	BIDI33
21	BIDI33
22	BIDI33
23	VSS33
24	VDD33
25	RSDS
26	RSDS
27	VSS33
28	RSDS
29	RSDS
30	VDD12L

Table 24. Pin Circuit Type of QFP-176 (Continued)

Pin Number	IO_TYPE
31	RSDS
32	RSDS
33	VDD33
34	RSDS
35	RSDS
36	VSS33
37	RSDS
38	RSDS
39	VDD33
40	RSDS
41	RSDS
42	VSS33
43	RSDS
44	RSDS
45	VDD12L
46	RSDS
47	RSDS
48	VDD33
49	RSDS
50	RSDS
51	VSS33
52	RSDS
53	RSDS
54	VDD33
55	RSDS
56	RSDS
57	VDD12L
58	RSDS
59	RSDS
60	VSS33
61	RSDS

Table 24. Pin Circuit Type of QFP-176 (Continued)

Pin Number	IO_TYPE
62	RSDS
63	VDD33
64	VSS33
65	TTL33
66	TTL33
67	TTL33
68	TTL33
69	TTL33
70	TTL33
71	VDD33
72	VSS33
73	TTL33
74	TTL33
75	TTL33
76	TTL33
77	TTL33
78	TTL33
79	VDD33
80	VSS33
81	BIDI33
82	BIDI33
83	BIDI33
84	BIDI33
85	BIDI33
86	BIDI33
87	BIDI33
88	BIDI33
89	BIDI33
90	BIDI33
91	BIDI33
92	BIDI33
93	BIDI33
94	VDD12L
95	VDD33
96	VSS33
97	HVSS
98	HVDD
99	SMC
100	SMC
101	SMC
102	SMC

Table 24. Pin Circuit Type of QFP-176 (Continued)

Pin Number	IO_TYPE
103	SMC
104	SMC
105	SMC
106	SMC
107	HVSS
108	HVDD
109	SMC
110	SMC
111	SMC
112	SMC
113	SMC
114	SMC
115	SMC
116	SMC
117	HVSS
118	HVDD
119	SMC
120	SMC
121	SMC
122	SMC
123	SMC
124	SMC
125	SMC
126	SMC
127	HVSS
128	HVDD
129	AVSS5
130	AVRH5
131	AVCC5
132	VDD50
133	VSS50
134	BIDI50
135	BIDI50
136	BIDI50
137	BIDI50
138	VSS50
139	VDD12H
140	BIDI50
141	BIDI50
142	BIDI50
143	BIDI50

Table 24. Pin Circuit Type of QFP-176 (Continued)

Pin Number	IO_TYPE
144	BIDI50
145	BIDI50
146	VSS50
147	VDD50
148	BIDI50
149	BIDI50
150	BIDI50
151	BIDI50
152	BIDI50
153	BIDI50
154	BIDI50
155	BIDI50
156	VSS50
157	VDD12H
158	BIDI50
159	BIDI50
160	BIDI50
161	BIDI50
162	BIDI50
163	BIDI50
164	BIDI50
165	BIDI50
166	VSS50
167	VDD50
168	BIDI50
169	BIDI50
170	I2C
171	I2C
172	JTAGO
173	JTAGIUP
174	JTAGIUP
175	JTAGIUP
176	JTAGIDN

IO Circuit Types
Table 25. IO Circuit Type

Type	Circuit	Remarks				
MAINOSC	<p style="text-align: center;">FCI or osc disable</p>	<p>High-speed oscillation circuit: Programmable between oscillation mode (external crystal or resonator connected to X0/X1 pins) and Fast external Clock Input (FCI) mode (external clock connected to X0 pin)</p> <p>Note: The built-in feedback resistor 'R' (1MΩm typical) is located between X0 and X1 and will be disabled in the Fast External Clock Input Mode (FCI).</p>				
SUBOSC	<p style="text-align: center;">osc disable</p>	<p>Low-speed oscillation circuit</p>				
JTAGIDN	<p style="text-align: center;">Pull-down Resistor</p>	<ul style="list-style-type: none"> ■ TTL level input pin ■ Pull-down resistor value: approx. 50 kΩ 				
JTAGIUP	<p style="text-align: center;">Pull-up Resistor</p>	<ul style="list-style-type: none"> ■ TTL level input pin ■ Pull-up resistor value: approx. 50 kΩ 				
JTAGO		<ul style="list-style-type: none"> ■ CMOS level output ■ Output Driving strength is fixed: <table style="margin-left: auto; margin-right: auto;"> <tr> <td style="text-align: center;">IOL</td> <td style="text-align: center;">IOH</td> </tr> <tr> <td style="text-align: center;">+1 mA</td> <td style="text-align: center;">-1mA</td> </tr> </table>	IOL	IOH	+1 mA	-1mA
IOL	IOH					
+1 mA	-1mA					

Table 25. IO Circuit Type (Continued)

Type	Circuit	Remarks																														
AVRH5		<ul style="list-style-type: none"> ■ A/D converter ref+ (AVRH5) power supply input pin with protection circuit ■ Flash devices do not have a protection circuit against VDP5 for pins AVRH5 																														
MODE		<ul style="list-style-type: none"> ■ CMOS Hysteresis input pin 																														
RSDS		<ul style="list-style-type: none"> ■ CMOS level output (programmable) <table border="1" style="width: 100%; border-collapse: collapse;"> <thead> <tr> <th>ODR[1:0]</th> <th>I_{OL}</th> <th>I_{OH}</th> </tr> </thead> <tbody> <tr> <td>00</td> <td>+2mA</td> <td>-2mA</td> </tr> <tr> <td>01</td> <td>+5mA</td> <td>-5mA</td> </tr> <tr> <td>10</td> <td>+10mA</td> <td>-10mA</td> </tr> <tr> <td>11</td> <td>+20mA</td> <td>-20mA</td> </tr> </tbody> </table> ■ Hysteresis input with input shutdown function ■ TTL input with input shutdown function <table border="1" style="width: 100%; border-collapse: collapse;"> <thead> <tr> <th>PIL</th> <th>Input buffer</th> <th>Levels</th> </tr> </thead> <tbody> <tr> <td>00</td> <td>Hysteresis</td> <td>20% / 80%</td> </tr> <tr> <td>10</td> <td>TTL</td> <td>0.8V / 2V</td> </tr> </tbody> </table> ■ Programmable pull-up and pull-down resistor: 33kΩ approx. ■ RSDS differential output data <table border="1" style="width: 100%; border-collapse: collapse;"> <thead> <tr> <th>BOOST</th> <th>I_d</th> </tr> </thead> <tbody> <tr> <td>0</td> <td>+2mA</td> </tr> <tr> <td>1</td> <td>+4mA</td> </tr> </tbody> </table> 	ODR[1:0]	I _{OL}	I _{OH}	00	+2mA	-2mA	01	+5mA	-5mA	10	+10mA	-10mA	11	+20mA	-20mA	PIL	Input buffer	Levels	00	Hysteresis	20% / 80%	10	TTL	0.8V / 2V	BOOST	I _d	0	+2mA	1	+4mA
ODR[1:0]	I _{OL}	I _{OH}																														
00	+2mA	-2mA																														
01	+5mA	-5mA																														
10	+10mA	-10mA																														
11	+20mA	-20mA																														
PIL	Input buffer	Levels																														
00	Hysteresis	20% / 80%																														
10	TTL	0.8V / 2V																														
BOOST	I _d																															
0	+2mA																															
1	+4mA																															

Table 25. IO Circuit Type (Continued)

Type	Circuit	Remarks																														
BIDI50		<ul style="list-style-type: none"> CMOS level output (programmable) <table border="1"> <thead> <tr> <th>ODR[1:0]</th> <th>I_{OL}</th> <th>I_{OH}</th> </tr> </thead> <tbody> <tr> <td>00</td> <td>+1mA</td> <td>-1mA</td> </tr> <tr> <td>01</td> <td>+2mA</td> <td>-2mA</td> </tr> <tr> <td>10</td> <td>+5mA</td> <td>-5mA</td> </tr> <tr> <td>11</td> <td>+2mA</td> <td>-2mA</td> </tr> </tbody> </table> <ul style="list-style-type: none"> Hysteresis input with input shutdown function Automotive input with input shutdown function TTL input with input shutdown function CMOS input with input shutdown function <table border="1"> <thead> <tr> <th>PIL</th> <th>Input buffer</th> <th>Levels</th> </tr> </thead> <tbody> <tr> <td>00</td> <td>Hysteresis</td> <td>20% / 80%</td> </tr> <tr> <td>01</td> <td>Automotive</td> <td>50% / 80%</td> </tr> <tr> <td>10</td> <td>TTL</td> <td>0.8V / 2V</td> </tr> <tr> <td>11</td> <td>CMOS</td> <td>20% / 80%</td> </tr> </tbody> </table> <ul style="list-style-type: none"> Programmable pull-up and pull-down resistor; 50kΩ approx. Analog input 	ODR[1:0]	I _{OL}	I _{OH}	00	+1mA	-1mA	01	+2mA	-2mA	10	+5mA	-5mA	11	+2mA	-2mA	PIL	Input buffer	Levels	00	Hysteresis	20% / 80%	01	Automotive	50% / 80%	10	TTL	0.8V / 2V	11	CMOS	20% / 80%
		ODR[1:0]	I _{OL}	I _{OH}																												
		00	+1mA	-1mA																												
		01	+2mA	-2mA																												
		10	+5mA	-5mA																												
		11	+2mA	-2mA																												
		PIL	Input buffer	Levels																												
		00	Hysteresis	20% / 80%																												
		01	Automotive	50% / 80%																												
		10	TTL	0.8V / 2V																												
11	CMOS	20% / 80%																														
BIDI33		<ul style="list-style-type: none"> CMOS level output <table border="1"> <thead> <tr> <th>ODR[1:0]</th> <th>I_{OL}</th> <th>I_{OH}</th> </tr> </thead> <tbody> <tr> <td>--</td> <td>+12mA</td> <td>-12mA</td> </tr> </tbody> </table> <ul style="list-style-type: none"> Hysteresis input with input shutdown function TTL input with input shutdown function <table border="1"> <thead> <tr> <th>PIL</th> <th>Input buffer</th> <th>Levels</th> </tr> </thead> <tbody> <tr> <td>00</td> <td>Hysteresis</td> <td>20% / 80%</td> </tr> <tr> <td>10</td> <td>TTL</td> <td>0.8V / 2V</td> </tr> </tbody> </table> <ul style="list-style-type: none"> Programmable pull-up and pull-down resistor: 33kΩ approx. 	ODR[1:0]	I _{OL}	I _{OH}	--	+12mA	-12mA	PIL	Input buffer	Levels	00	Hysteresis	20% / 80%	10	TTL	0.8V / 2V															
		ODR[1:0]	I _{OL}	I _{OH}																												
		--	+12mA	-12mA																												
		PIL	Input buffer	Levels																												
		00	Hysteresis	20% / 80%																												
		10	TTL	0.8V / 2V																												

Table 25. IO Circuit Type (Continued)

Type	Circuit	Remarks																														
TTL33		<ul style="list-style-type: none"> CMOS level output (programmable) <table border="1"> <thead> <tr> <th>ODR[1:0]</th> <th>I_{OL}</th> <th>I_{OH}</th> </tr> </thead> <tbody> <tr> <td>00</td> <td>+2mA</td> <td>-2mA</td> </tr> <tr> <td>01</td> <td>+5mA</td> <td>-5mA</td> </tr> <tr> <td>10</td> <td>+10mA</td> <td>-10mA</td> </tr> <tr> <td>11</td> <td>+20mA</td> <td>-20mA</td> </tr> </tbody> </table> <ul style="list-style-type: none"> Hysteresis input with input shutdown function TTL input with input shutdown function <table border="1"> <thead> <tr> <th>PIL</th> <th>Input buffer</th> <th>Levels</th> </tr> </thead> <tbody> <tr> <td>00</td> <td>Hysteresis</td> <td>20% / 80%</td> </tr> <tr> <td>10</td> <td>TTL</td> <td>0.8V / 2V</td> </tr> </tbody> </table> <ul style="list-style-type: none"> Programmable pull-up and pull-down resistor: 33kΩ approx. 	ODR[1:0]	I _{OL}	I _{OH}	00	+2mA	-2mA	01	+5mA	-5mA	10	+10mA	-10mA	11	+20mA	-20mA	PIL	Input buffer	Levels	00	Hysteresis	20% / 80%	10	TTL	0.8V / 2V						
		ODR[1:0]	I _{OL}	I _{OH}																												
		00	+2mA	-2mA																												
		01	+5mA	-5mA																												
		10	+10mA	-10mA																												
		11	+20mA	-20mA																												
		PIL	Input buffer	Levels																												
		00	Hysteresis	20% / 80%																												
		10	TTL	0.8V / 2V																												
		SMC		<ul style="list-style-type: none"> CMOS level output (programmable) <table border="1"> <thead> <tr> <th>ODR[1:0]</th> <th>I_{OL}</th> <th>I_{OH}</th> </tr> </thead> <tbody> <tr> <td>00</td> <td>+1mA</td> <td>-1mA</td> </tr> <tr> <td>01</td> <td>+2mA</td> <td>-2mA</td> </tr> <tr> <td>10</td> <td>+30mA</td> <td>-30mA</td> </tr> <tr> <td>11</td> <td>+5mA</td> <td>-5mA</td> </tr> </tbody> </table> <ul style="list-style-type: none"> Hysteresis input with input shutdown function Automotive input with input shutdown function TTL input with input shutdown function CMOS input with input shutdown function <table border="1"> <thead> <tr> <th>PIL</th> <th>Input buffer</th> <th>Levels</th> </tr> </thead> <tbody> <tr> <td>00</td> <td>Hysteresis</td> <td>20% / 80%</td> </tr> <tr> <td>01</td> <td>Automotive</td> <td>50% / 80%</td> </tr> <tr> <td>10</td> <td>TTL</td> <td>0.8V / 2V</td> </tr> <tr> <td>11</td> <td>CMOS</td> <td>20% / 80%</td> </tr> </tbody> </table> <ul style="list-style-type: none"> Programmable pull-up resistor and pull down resistor: 50kΩ approx. 	ODR[1:0]	I _{OL}	I _{OH}	00	+1mA	-1mA	01	+2mA	-2mA	10	+30mA	-30mA	11	+5mA	-5mA	PIL	Input buffer	Levels	00	Hysteresis	20% / 80%	01	Automotive	50% / 80%	10	TTL	0.8V / 2V	11
ODR[1:0]	I _{OL}			I _{OH}																												
00	+1mA			-1mA																												
01	+2mA			-2mA																												
10	+30mA			-30mA																												
11	+5mA			-5mA																												
PIL	Input buffer			Levels																												
00	Hysteresis			20% / 80%																												
01	Automotive			50% / 80%																												
10	TTL			0.8V / 2V																												
11	CMOS	20% / 80%																														

Table 25. IO Circuit Type (Continued)

Type	Circuit	Remarks																								
I2C		<ul style="list-style-type: none"> CMOS level output (programmable) 																								
		<table border="1"> <thead> <tr> <th>ODR[1:0]</th> <th>IIC_EN</th> <th>I_{OL}</th> <th>I_{OH}</th> </tr> </thead> <tbody> <tr> <td>00</td> <td>0</td> <td>+1mA</td> <td>-1mA</td> </tr> <tr> <td>01</td> <td>0</td> <td>+2mA</td> <td>-2mA</td> </tr> <tr> <td>10</td> <td>0</td> <td>+5mA</td> <td>-5mA</td> </tr> <tr> <td>11</td> <td>0</td> <td>+2mA</td> <td>-2mA</td> </tr> <tr> <td>--</td> <td>1</td> <td>+3mA</td> <td>(Pseudo Open Drain)*1</td> </tr> </tbody> </table>	ODR[1:0]	IIC_EN	I _{OL}	I _{OH}	00	0	+1mA	-1mA	01	0	+2mA	-2mA	10	0	+5mA	-5mA	11	0	+2mA	-2mA	--	1	+3mA	(Pseudo Open Drain)*1
		ODR[1:0]	IIC_EN	I _{OL}	I _{OH}																					
		00	0	+1mA	-1mA																					
		01	0	+2mA	-2mA																					
		10	0	+5mA	-5mA																					
		11	0	+2mA	-2mA																					
		--	1	+3mA	(Pseudo Open Drain)*1																					
		<ul style="list-style-type: none"> Hysteresis input with input shutdown function Automotive input with input shutdown function TTL input with input shutdown function CMOS input with input shutdown function 																								
		<ul style="list-style-type: none"> I2C_enable is high, when the corresponding PCFGRxxx_POF value is set to I2C function and the I2C interface module is enabled. 																								
<p>Note *1: For Pseudo Open Drain output logic value 1, Push/Pull CMOS driver is switched to HIZ state.</p>																										
<table border="1"> <thead> <tr> <th>PIL</th> <th>Input buffer</th> <th>Levels</th> </tr> </thead> <tbody> <tr> <td>00</td> <td>Hysteresis</td> <td>20% / 80%</td> </tr> <tr> <td>01</td> <td>Automotive</td> <td>50% / 80%</td> </tr> <tr> <td>10</td> <td>TTL</td> <td>0.8V / 2V</td> </tr> <tr> <td>11</td> <td>CMOS</td> <td>20% / 80%</td> </tr> </tbody> </table>	PIL	Input buffer	Levels	00	Hysteresis	20% / 80%	01	Automotive	50% / 80%	10	TTL	0.8V / 2V	11	CMOS	20% / 80%											
PIL	Input buffer	Levels																								
00	Hysteresis	20% / 80%																								
01	Automotive	50% / 80%																								
10	TTL	0.8V / 2V																								
11	CMOS	20% / 80%																								
<ul style="list-style-type: none"> Programmable pull-up resistor and pull-down resistor: 50kΩ approx. 																										

Packages

Figure 2. QFP-176 Package Dimension

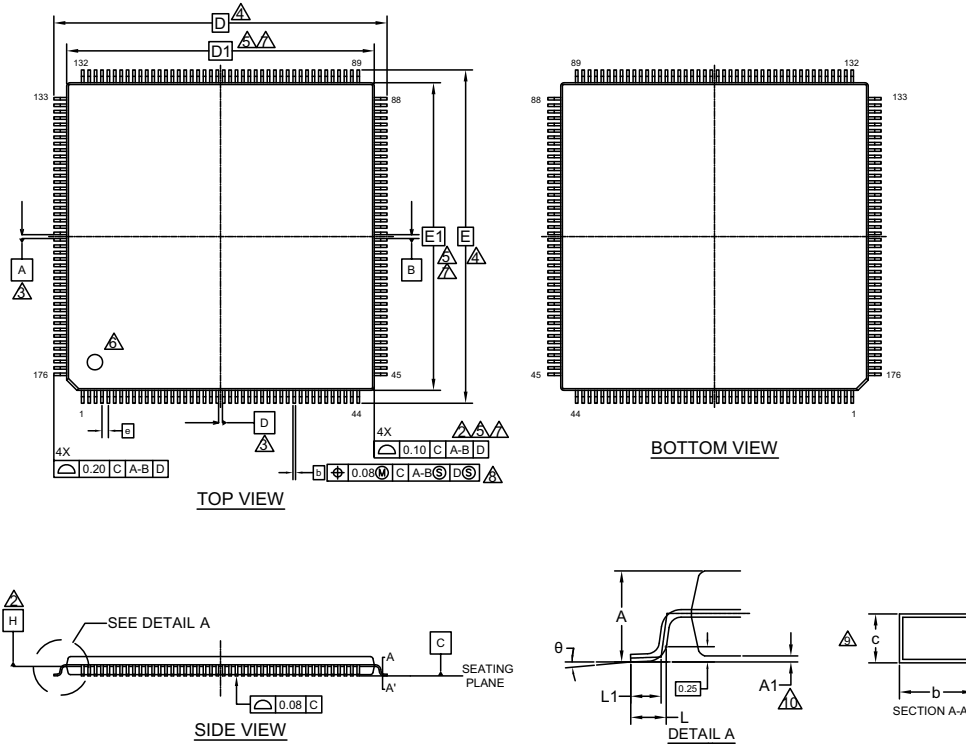

SYMBOL	DIMENSIONS		
	MIN.	NOM.	MAX.
A	—	—	1.70
A1	0.05	—	0.15
b	0.17	0.22	0.27
c	0.09	—	0.20
D	26.00 BSC		
D1	24.00 BSC		
e	0.50 BSC		
E	26.00 BSC		
E1	24.00 BSC		
L	0.45	0.60	0.75
L1	0.30	0.50	0.70
θ	0°	—	8°

NOTES

- ALL DIMENSIONS ARE IN MILLIMETERS.
- DATUM PLANE H IS LOCATED AT THE BOTTOM OF THE MOLD PARTING LINE COINCIDENT WITH WHERE THE LEAD EXITS THE BODY.
- DATUMS A-B AND D TO BE DETERMINED AT DATUM PLANE H.
- TO BE DETERMINED AT SEATING PLANE C.
- DIMENSIONS D1 AND E1 DO NOT INCLUDE MOLD PROTRUSION. ALLOWABLE PROTRUSION IS 0.25mm PRE SIDE. DIMENSIONS D1 AND E1 INCLUDE MOLD MISMATCH AND ARE DETERMINED AT DATUM PLANE H.
- DETAILS OF PIN 1 IDENTIFIER ARE OPTIONAL BUT MUST BE LOCATED WITHIN THE ZONE INDICATED.
- REGARDLESS OF THE RELATIVE SIZE OF THE UPPER AND LOWER BODY SECTIONS, DIMENSIONS D1 AND E1 ARE DETERMINED AT THE LARGEST FEATURE OF THE BODY EXCLUSIVE OF MOLD FLASH AND GATE BURRS, BUT INCLUDING ANY MISMATCH BETWEEN THE UPPER AND LOWER SECTIONS OF THE MOLDER BODY.
- DIMENSION b DOES NOT INCLUDE DAMBAR PROTRUSION. THE DAMBAR PROTRUSION (S) SHALL NOT CAUSE THE LEAD WIDTH TO EXCEED b MAXIMUM BY MORE THAN 0.08mm. DAMBAR CANNOT BE LOCATED ON THE LOWER RADIUS OR THE LEAD FOOT.
- THESE DIMENSIONS APPLY TO THE FLAT SECTION OF THE LEAD BETWEEN 0.10mm AND 0.25mm FROM THE LEAD TIP.
- A1 IS DEFINED AS THE DISTANCE FROM THE SEATING PLANE TO THE LOWEST POINT OF THE PACKAGE BODY.

002-15150 **

Interrupt/DMA

This section shows the allocation of interrupt and interrupt vector/interrupt register.

Interrupt Table

Table 26. Interrupt Table

Interrupt Line Number	Interrupt Name	Interrupt Description
0	SYSCIRQ	Status Interrupt from System Controller (SYSC_SYSSTS:RUNDN is set when current RUN Profile was successfully applied)
1	WDGIRQ	Watchdog pre-warning Interrupt (WDG_INT:IRQ_FLAG is set when watchdog error condition is detected (missing or wrong WDG clearing procedure))
15	MLB0CINT	MLB0 Channel Interrupt (check MLBn_CSCRn:[15:0] for detailed Channel interrupt cause)
16	MLB0SINT	MLB0 System Interrupt (check MLB0_SSCRn:[7:0] for detailed System interrupt cause)
22	GFXIRQ0	GFX Interrupt 0 (check GFXGCTR_IntStatus0, GFXGCTR_IntStatus1, GFXGCTR_IntMap0, GFXGCTR_IntMap1 for detailed GFX Interrupt 0 cause)
23	GFXIRQ1	GFX Interrupt 1 (check GFXGCTR_IntStatus0, GFXGCTR_IntStatus1, GFXGCTR_IntMap0, GFXGCTR_IntMap1 for detailed GFX Interrupt 1 cause)
30	ADC0IRQ	ADC0 Conversion End Interrupt (ADC0_CS1:INT signals end of conversion for current channel (this flag is mirrored in ADC0_CS3:INT))
31	ADC0IRQ2	ADC0 Scan End Interrupt (ADC0_CS3:INT2 is set when the current scan over selected channels has finished)
32	ADC0IRQR	ADC0 Range Comparator Interrupt (ADC0_RCOINT10~32:RCOINT[15:0] are set when corresponding ADC result is outside selected range (check ADC0_RCOOF10~32:RCOOF[15:0] and the selected mode ADC0_RCOIRS10~32:RCOIRS[15:0] for interrupt cause)
33	ADC0IRQP	ADC0 Pulse Detection Interrupt (ADC0_PCZF10~32:CTPZF[15:0] are set when corresponding pulse counter becomes zero)
34	RRCFGIRQERR	Retention RAM Single Bit Error (RRCFG_CSR:CEIF is set when a correctable error occurred during any read access to Retention RAM)
35	SRCFGIRQERR	System RAM Single Bit Error (SRCFG_ERRFLG:SECFLG is set when a correctable error occurred during any read access to SRAM)
36	TCFCFGIRQ	Instruction Flash Write Completion Interrupt (TCFCFG_FSTATn:RDYINT is set on the rising edge of TCFCFG_FSTATn:RDY flag) Instruction Flash Hang Interrupt (TCFCFG_FSTATn:HANGINT is set when a hang condition occurs in Instruction Flash) Instruction Flash Single Bit Error (TCFCFG_FSECIR:SECINT is set when a correctable error occurred during any read access to Instruction Flash)
37	EEFCFGIRQERR	Data Flash Error Interrupt (EEFCFG_SR:ERRINT is set if the write command sequencer is disabled in ongoing operation or if any write error occurs during ongoing transfer) Data Flash Hang Interrupt (EEFCFG_SR:HANGINT is set when a hang condition occurs in Data Flash)
38	IRQ0IRQERR	IUNIT Vector RAM Single Bit Error (IRQ0_EEI:EEIS is set when a correctable error occurred during any read access to Interrupt Controller RAM)
41	EEFCFGIRQ	Data Flash Write Completion Interrupt (EEFCFG_SR:RDYINT is set on the rising edge of EEFCFG_SR:RDY flag) Data Flash Single Bit Error (EEFCFG_SECIR:SECINT is set when a correctable error occurred during any read access to Data Flash)
42	EICU0IRQ	External Interrupt Capture Unit 0 Interrupt (EICU0_CNFR:DATAVALID is set when 256 samples have been taken at the selected external interrupt input pin)
43	HSSPI0IRQRX	HSSPI0 Receive Interrupt (check HSSPI0_RXF:[6:0] for detailed RX interrupt cause)
44	HSSPI0IRQTX	HSSPI0 Transmit Interrupt (check HSSPI0_TXF:[6:0] for detailed TX interrupt cause)
45	SHE	SHE Error Interrupt (check SHE_IF_CFG_SHE_IRQ[23:16] for detailed SHE Error interrupt cause)
48	SHE	SHE General Interrupt (check SHE_IF_CFG_SHE_IRQ[5:0] for detailed SHE General interrupt cause)
49	SPI0IRQRX	SPI0 Receive Interrupt (check SPI0_RXF:[6:0] for detailed RX interrupt cause)
50	SPI0IRQTX	SPI0 Transmit Interrupt (check SPI0_TXF:[6:0] for detailed TX interrupt cause)
52	SPI1IRQRX	SPI1 Receive Interrupt (check SPI1_RXF:[6:0] for detailed RX interrupt cause)
53	SPI1IRQTX	SPI1 Transmit Interrupt (check SPI1_TXF:[6:0] for detailed TX interrupt cause)
55	SPI2IRQRX	SPI2 Receive Interrupt (check SPI2_RXF:[6:0] for detailed RX interrupt cause)
56	SPI2IRQTX	SSPI2 Transmit Interrupt (check SPI2_TXF:[6:0] for detailed TX interrupt cause)
61	CAN0IRQ	CAN0 Interrupt (this interrupt is called depending on CTRL0:EIE, CTRL0:SIE and the corresponding transmit/receive interrupt enable flags in the message objects TXE/RXE)

Table 26. Interrupt Table (Continued)

Interrupt Line Number	Interrupt Name	Interrupt Description
62	CAN1IRQ	CAN1 Interrupt (this interrupt is called depending on CTRLR1:EIE, CTRLR1:SIE and the corresponding transmit/receive interrupt enable flags in the message objects TXE/RXE)
69	EIC0IRQ0	External Interrupt 0 (EIC0_EIRR:ER0 is set when an interrupt condition is detected at the corresponding input pin)
70	EIC0IRQ1	External Interrupt 1 (EIC0_EIRR:ER1 is set when an interrupt condition is detected at the corresponding input pin)
71	EIC0IRQ2	External Interrupt 2 (EIC0_EIRR:ER2 is set when an interrupt condition is detected at the corresponding input pin)
72	EIC0IRQ3	External Interrupt 3 (EIC0_EIRR:ER3 is set when an interrupt condition is detected at the corresponding input pin)
73	EIC0IRQ4	External Interrupt 4 (EIC0_EIRR:ER4 is set when an interrupt condition is detected at the corresponding input pin)
74	EIC0IRQ5	External Interrupt 5 (EIC0_EIRR:ER5 is set when an interrupt condition is detected at the corresponding input pin)
75	EIC0IRQ6	External Interrupt 6 (EIC0_EIRR:ER6 is set when an interrupt condition is detected at the corresponding input pin)
76	EIC0IRQ7	External Interrupt 7 (EIC0_EIRR:ER7 is set when an interrupt condition is detected at the corresponding input pin)
77	EIC0IRQ8	External Interrupt 8 (EIC0_EIRR:ER8 is set when an interrupt condition is detected at the corresponding input pin)
78	EIC0IRQ9	External Interrupt 9 (EIC0_EIRR:ER9 is set when an interrupt condition is detected at the corresponding input pin)
79	EIC0IRQ10	External Interrupt 10 (EIC0_EIRR:ER10 is set when an interrupt condition is detected at the corresponding input pin)
80	EIC0IRQ11	External Interrupt 11 (EIC0_EIRR:ER11 is set when an interrupt condition is detected at the corresponding input pin)
81	EIC0IRQ12	External Interrupt 12 (EIC0_EIRR:ER12 is set when an interrupt condition is detected at the corresponding input pin)
82	EIC0IRQ13	External Interrupt 13 (EIC0_EIRR:ER13 is set when an interrupt condition is detected at the corresponding input pin)
83	EIC0IRQ14	External Interrupt 14 (EIC0_EIRR:ER14 is set when an interrupt condition is detected at the corresponding input pin)
84	EIC0IRQ15	External Interrupt 15 (EIC0_EIRR:ER15 is set when an interrupt condition is detected at the corresponding input pin)
85	EIC0IRQ16	External Interrupt 16 (EIC0_EIRR:ER16 is set when an interrupt condition is detected at the corresponding input pin)
86	EIC0IRQ17	External Interrupt 17 (EIC0_EIRR:ER17 is set when an interrupt condition is detected at the corresponding input pin)
87	EIC0IRQ18	External Interrupt 18 (EIC0_EIRR:ER18 is set when an interrupt condition is detected at the corresponding input pin)
88	EIC0IRQ19	External Interrupt 19 (EIC0_EIRR:ER19 is set when an interrupt condition is detected at the corresponding input pin)
89	EIC0IRQ20	External Interrupt 20 (EIC0_EIRR:ER20 is set when an interrupt condition is detected at the corresponding input pin)
90	EIC0IRQ21	External Interrupt 21 (EIC0_EIRR:ER21 is set when an interrupt condition is detected at the corresponding input pin)
91	EIC0IRQ22	External Interrupt 22 (EIC0_EIRR:ER22 is set when an interrupt condition is detected at the corresponding input pin)
92	EIC0IRQ23	External Interrupt 23 (EIC0_EIRR:ER23 is set when an interrupt condition is detected at the corresponding input pin)
93	EIC0IRQ24	External Interrupt 24 (EIC0_EIRR:ER24 is set when an interrupt condition is detected at the corresponding input pin)
94	EIC0IRQ25	External Interrupt 25 (EIC0_EIRR:ER25 is set when an interrupt condition is detected at the corresponding input pin)
95	EIC0IRQ26	External Interrupt 26 (EIC0_EIRR:ER26 is set when an interrupt condition is detected at the corresponding input pin)
96	EIC0IRQ27	External Interrupt 27 (EIC0_EIRR:ER27 is set when an interrupt condition is detected at the corresponding input pin)
97	EIC0IRQ28	External Interrupt 28 (EIC0_EIRR:ER28 is set when an interrupt condition is detected at the corresponding input pin)
98	EIC0IRQ29	External Interrupt 29 (EIC0_EIRR:ER29 is set when an interrupt condition is detected at the corresponding input pin)
99	EIC0IRQ30	External Interrupt 30 (EIC0_EIRR:ER30 is set when an interrupt condition is detected at the corresponding input pin)
100	EIC0IRQ31	External Interrupt 31 (EIC0_EIRR:ER31 is set when an interrupt condition is detected at the corresponding input pin)
101	RTCIRQ	Real Time Clock Interrupt (check RTC_WINS:[6:0] for detailed Real Time Clock interrupt cause)
102	SG0IRQ	Sound Generator 0 Interrupt (SG0_CR1:ZAIN (zero amplitude interrupt), SG0_CR1:TCINT (tone pulse count interrupt), SG0_CR1:AMINT (amplitude match interrupt))
104	FRT0IRQ	Free Running Timer 0 Interrupt (FRT0_TCCS:IVF (compare clear match/counter overflow), FRT0_ETCCS:IRQZF (counter zero detection))
105	FRT1IRQ	Free Running Timer 1 Interrupt (FRT1_TCCS:IVF (compare clear match/counter overflow), FRT1_ETCCS:IRQZF (counter zero detection))

Table 26. Interrupt Table (Continued)

Interrupt Line Number	Interrupt Name	Interrupt Description
106	FRT2IRQ	Free Running Timer 2 Interrupt (FRT2_TCCS:IVF (compare clear match/counter overflow), FRT2_ETCCS:IRQZF (counter zero detection))
107	FRT3IRQ	Free Running Timer 3 Interrupt (FRT3_TCCS:IVF (compare clear match/counter overflow), FRT3_ETCCS:IRQZF (counter zero detection))
112	FRT16IRQ	Free Running Timer 16 Interrupt (FRT16_TCCS:IVF (compare clear match/counter overflow), FRT16_ETCCS:IRQZF (counter zero detection))
113	FRT17IRQ	Free Running Timer 17 Interrupt (FRT17_TCCS:IVF (compare clear match/counter overflow), FRT17_ETCCS:IRQZF (counter zero detection))
114	FRT18IRQ	Free Running Timer 18 Interrupt (FRT0_TCCS:IVF (compare clear match/counter overflow), FRT18_ETCCS:IRQZF (counter zero detection))
115	FRT19IRQ	Free Running Timer 19 Interrupt (FRT19_TCCS:IVF (compare clear match/counter overflow), FRT19_ETCCS:IRQZF (counter zero detection))
124	ICU2IRQ0	Input Capture Unit 2 channel 0 Interrupt (ICU2_ICEICS01:IDSE0)
125	ICU2IRQ1	Input Capture Unit 2 channel 1 Interrupt (ICU2_ICEICS01:IDSE1)
126	ICU3IRQ0	Input Capture Unit 3 channel 0 Interrupt (ICU3_ICEICS01:IDSE0)
127	ICU3IRQ1	Input Capture Unit 3 channel 1 Interrupt (ICU3_ICEICS01:IDSE1)
132	ICU18IRQ0	Input Capture Unit 18 channel 0 Interrupt (ICU18_ICEICS01:IDSE0)
133	ICU18IRQ1	Input Capture Unit 18 channel 1 Interrupt (ICU18_ICEICS01:IDSE1)
134	ICU19IRQ0	Input Capture Unit 19 channel 0 Interrupt (ICU19_ICEICS01:IDSE0)
135	ICU19IRQ1	Input Capture Unit 19 channel 1 Interrupt (ICU19_ICEICS01:IDSE1)
136	OCU0IRQ0	Output Compare Unit 1 channel 0 Interrupt (OCU0_OSR01:ICP0)
137	OCU0IRQ1	Output Compare Unit 0 channel 1 Interrupt (OCU0_OSR01:ICP1)
138	OCU1IRQ0	Output Compare Unit 1 channel 0 Interrupt (OCU1_OSR01:ICP0)
139	OCU1IRQ1	Output Compare Unit 1 channel 1 Interrupt (OCU1_OSR01:ICP1)
144	OCU16IRQ0	Output Compare Unit 16 channel 0 Interrupt (OCU16_OSR01:ICP0)
145	OCU16IRQ1	Output Compare Unit 16 channel 1 Interrupt (OCU16_OSR01:ICP1)
146	OCU17IRQ0	Output Compare Unit 17 channel 0 Interrupt (OCU17_OSR01:ICP0)
147	OCU17IRQ1	Output Compare Unit 17 channel 1 Interrupt (OCU17_OSR01:ICP1)
152	USART0IRQRX	LIN USART 0 Receive Interrupt (UART0_SSR:RDF (receive data full), USART0_ESR:RXHRI (automatic reception of LIN header completed))
153	USART0IRQTX	LIN USART 0 Transmit Interrupt (UART0_SSR:TDRE (transmission data empty), USART0_ECCR:RBI = 1 and USART0_ECCR:TBI = 1 and USART0_ECCR:BIE = 1 (bus idle interrupt), USART0_ESR:LBSOF (transmitted last bit in synchronous/asynchronous mode), USART0_ESR:TXHRI (automatic transmission of LIN header completed))
154	USART0IRQERR	LIN USART 0 Error Interrupt (USART0_SSR:PE (parity error), USART0_SSR:ORE (overrun error), USART0_SSR:FRE (framing error), USART0_CSCR:CRCERR (error found in checksum validation), USART0_ESR:SYNFE (sync field detection timeout), USART0_ESR:BUSERR (bus error occurred), USART0_ESR:PEFRD (parity error in received frame ID))
158	USART6IRQRX	LIN USART 6 Receive Interrupt (UART6_SSR:RDF (receive data full), USART6_ESR:RXHRI (automatic reception of LIN header completed))
159	USART6IRQTX	LIN USART 6 Transmit Interrupt (UART0_SSR:TDRE (transmission data empty), USART6_ECCR:RBI = 1 and USART6_ECCR:TBI = 1 and USART6_ECCR:BIE = 1 (bus idle interrupt), USART0_ESR:LBSOF (transmitted last bit in synchronous/asynchronous mode), USART0_ESR:TXHRI (automatic transmission of LIN header completed))
160	USART6IRQERR	LIN USART 6 Error Interrupt (USART0_SSR:PE (parity error), USART6_SSR:ORE (overrun error), USART6_SSR:FRE (framing error), USART6_CSCR:CRCERR (error found in checksum validation), USART0_ESR:SYNFE (sync field detection timeout), USART0_ESR:BUSERR (bus error occurred), USART0_ESR:PEFRD (parity error in received frame ID))
164	DMA0IRQD0	DMA0 Completion Interrupt for channels 0 + 8*n (DMACDIRQ1:DIRQ[24, 16, 8, 0] and DMACDIRQ2:DIRQ[56, 48, 40, 32])
165	DMA0IRQD1	DMA0 Completion Interrupt for channels 1 + 8*n (DMACDIRQ1:DIRQ[25, 17, 9, 1] and DMACDIRQ2:DIRQ[57, 49, 41, 33])
166	DMA0IRQD2	DMA0 Completion Interrupt for channels 2 + 8*n (DMACDIRQ1:DIRQ[26, 18, 10, 2] and DMACDIRQ2:DIRQ[58, 50, 42, 34])
167	DMA0IRQD3	DMA0 Completion Interrupt for channels 3 + 8*n (DMACDIRQ1:DIRQ[27, 19, 11, 3] and DMACDIRQ2:DIRQ[59, 51, 43, 35])

Table 26. Interrupt Table (Continued)

Interrupt Line Number	Interrupt Name	Interrupt Description
168	DMA0IRQD4	DMA0 Completion Interrupt for channels 4 + 8*n (DMACDIRQ1:DIRQ[28, 20, 12, 4] and DMACDIRQ2:DIRQ[60, 52, 44, 36])
169	DMA0IRQD5	DMA0 Completion Interrupt for channels 5 + 8*n (DMACDIRQ1:DIRQ[29, 21, 13, 5] and DMACDIRQ2:DIRQ[61, 53, 45, 37])
170	DMA0IRQD6	DMA0 Completion Interrupt for channels 6 + 8*n (DMACDIRQ1:DIRQ[30, 22, 14, 6] and DMACDIRQ2:DIRQ[62, 54, 46, 38])
171	DMA0IRQD7	DMA0 Completion Interrupt for channels 7 + 8*n (DMACDIRQ1:DIRQ[31, 23, 15, 7] and DMACDIRQ2:DIRQ[63, 55, 47, 39])
172	DMA0IRQERR	DMA0 Error Interrupt (DMACEDIRQ1:EDIRQ[31:0] and DMACEDIRQ2:EDIRQ[63:32])
173	MSCTIRQ	Main Source Clock Timer Interrupt (SYSC_MAINSCTSTATR:INTF is set when counter matches or is greater than the corresponding compare register)
174	SSCTIRQ	Sub Source Clock Timer Interrupt (SYSC_SUBSCTSTATR:INTF is set when counter matches or is greater than the corresponding compare register)
175	RCSTIRQ	RC Source Clock Timer Interrupt (SYSC_RCSTSTATR:INTF is set when counter matches or is greater than the corresponding compare register)
176	SRCSCTIRQ	Slow RC Source Clock Timer Interrupt (SYSC_SRCSTSTATR:INTF is set when counter matches or is greater than the corresponding compare register)
177	CORE0IRQ	CORTEX R4 Performance Monitor Interrupt
178	RLT0IRQ	Reload Timer 0 Interrupt (RLT0_TMCSR:UF is set when reload timer counter underflows)
179	RLT1IRQ	Reload Timer 1 Interrupt (RLT1_TMCSR:UF is set when reload timer counter underflows)
180	RLT2IRQ	Reload Timer 2 Interrupt (RLT2_TMCSR:UF is set when reload timer counter underflows)
181	RLT3IRQ	Reload Timer 3 Interrupt (RLT3_TMCSR:UF is set when reload timer counter underflows)
182	RLT4IRQ	Reload Timer 4 Interrupt (RLT4_TMCSR:UF is set when reload timer counter underflows)
183	RLT5IRQ	Reload Timer 5 Interrupt (RLT5_TMCSR:UF is set when reload timer counter underflows)
184	RLT6IRQ	Reload Timer 6 Interrupt (RLT6_TMCSR:UF is set when reload timer counter underflows)
185	RLT7IRQ	Reload Timer 7 Interrupt (RLT7_TMCSR:UF is set when reload timer counter underflows)
186	RLT8IRQ	Reload Timer 8 Interrupt (RLT8_TMCSR:UF is set when reload timer counter underflows)
187	RLT9IRQ	Reload Timer 9 Interrupt (RLT9_TMCSR:UF is set when reload timer counter underflows)
194	UDC0IRQ0	Up/Down Counter 0 channel 0 Interrupt (UDN0_CS0:OVFF (overflow), UDFE (underflow), CMPF (compare match))
195	UDC0IRQ1	Up/Down Counter 0 channel 1 Interrupt (UDN0_CS1:OVFF (overflow), UDFE (underflow), CMPF (compare match))
198	I2S0IRQ	I2S0 Interrupt (check I2S0_STATUS:[31:24], [19], [17:16] for detailed interrupt cause)
199	I2S1IRQ	I2S1 Interrupt (check I2S1_STATUS:[31:24], [19], [17:16] for detailed interrupt cause)
202	I2C0IRQ	I2C0 Interrupt (I2C0_IBCSR_INT (masked by I2C0_IBCSR_INTE) set after end of 1 byte data transfer or reception including acknowledge bit (bus master, addressed as slave, GCA received, Arbitration lost), I2C0_IBCSR_BER (masked by I2C0_IBCSR_BEIE) indicates bus error (Start- or Stop-Condition detected at wrong places))
203	I2C0IRQERR	I2C0 Error Interrupt (I2C0_IBCSR_BER (masked by I2C0_IEIER_BEREIE) indicates bus error (Start- or Stop-Condition detected at wrong places), I2C0_IBCSR_AL (masked by I2C0_IEIER_ALEIE) indicates arbitration lost)
206	CRC0IRQ	CRC0 Interrupt (CRC0_CFG:CIRQ set after checksum is calculated and available in register)
208	PPG0IRQ	Programmable Pulse Generator 0 Interrupt (PPG0_PCN:IRQF set depending on PPG0_PCN:IRS[2:0], PPG0_EPCN1:TRIG set when PWM output generation is started, PPG0_EPCN2:[7:0]). See detailed description in FCR4 32-Bit Microcontroller FCR4 Cluster Series Hardware Manual (002-09388). Programmable Pulse Generator 0 Interrupt
209	PPG1IRQ	Programmable Pulse Generator 1 Interrupt (PPG1_PCN:IRQF set depending on PPG1_PCN:IRS[2:0], PPG1_EPCN1:TRIG set when PWM output generation is started, PPG1_EPCN2:[7:0]). See detailed description in FCR4 32-Bit Microcontroller FCR4 Cluster Series Hardware Manual (002-09388).
210	PPG2IRQ	Programmable Pulse Generator 2 Interrupt (PPG2_PCN:IRQF set depending on PPG2_PCN:IRS[2:0], PPG2_EPCN1:TRIG set when PWM output generation is started, PPG2_EPCN2:[7:0]). See detailed description in FCR4 32-Bit Microcontroller FCR4 Cluster Series Hardware Manual (002-09388).
211	PPG3IRQ	Programmable Pulse Generator 3 Interrupt (PPG3_PCN:IRQF set depending on PPG3_PCN:IRS[2:0], PPG3_EPCN1:TRIG set when PWM output generation is started, PPG3_EPCN2:[7:0]). See detailed description in FCR4 32-Bit Microcontroller FCR4 Cluster Series Hardware Manual (002-09388).

Table 26. Interrupt Table (Continued)

Interrupt Line Number	Interrupt Name	Interrupt Description
212	PPG4IRQ	Programmable Pulse Generator 4 Interrupt (PPG4_PCN:IRQF set depending on PPG4_PCN:IRS[2:0], PPG4_EPCN1:TRIG set when PWM output generation is started, PPG4_EPCN2:[7:0]). See detailed description in FCR4 32-Bit Microcontroller FCR4 Cluster Series Hardware Manual (002-09388).
213	PPG5IRQ	Programmable Pulse Generator 5 Interrupt (PPG5_PCN:IRQF set depending on PPG5_PCN:IRS[2:0], PPG5_EPCN1:TRIG set when PWM output generation is started, PPG5_EPCN2:[7:0]). See detailed description in FCR4 32-Bit Microcontroller FCR4 Cluster Series Hardware Manual (002-09388).
214	PPG6IRQ	Programmable Pulse Generator 6 Interrupt (PPG6_PCN:IRQF set depending on PPG6_PCN:IRS[2:0], PPG6_EPCN1:TRIG set when PWM output generation is started, PPG6_EPCN2:[7:0]). See detailed description in FCR4 32-Bit Microcontroller FCR4 Cluster Series Hardware Manual (002-09388).
215	PPG7IRQ	Programmable Pulse Generator 7 Interrupt (PPG7_PCN:IRQF set depending on PPG7_PCN:IRS[2:0], PPG7_EPCN1:TRIG set when PWM output generation is started, PPG7_EPCN2:[7:0]). See detailed description in FCR4 32-Bit Microcontroller FCR4 Cluster Series Hardware Manual (002-09388).
216	PPG8IRQ	Programmable Pulse Generator 8 Interrupt (PPG8_PCN:IRQF set depending on PPG8_PCN:IRS[2:0], PPG8_EPCN1:TRIG set when PWM output generation is started, PPG8_EPCN2:[7:0]). See detailed description in FCR4 32-Bit Microcontroller FCR4 Cluster Series Hardware Manual (002-09388).
217	PPG9IRQ	Programmable Pulse Generator 9 Interrupt (PPG9_PCN:IRQF set depending on PPG9_PCN:IRS[2:0], PPG9_EPCN1:TRIG set when PWM output generation is started, PPG9_EPCN2:[7:0]). See detailed description in FCR4 32-Bit Microcontroller FCR4 Cluster Series Hardware Manual (002-09388).
218	PPG10IRQ	Programmable Pulse Generator 10 Interrupt (PPG10_PCN:IRQF set depending on PPG10_PCN:IRS[2:0], PPG10_EPCN1:TRIG set when PWM output generation is started, PPG10_EPCN2:[7:0]). See detailed description in FCR4 32-Bit Microcontroller FCR4 Cluster Series Hardware Manual (002-09388).
219	PPG11IRQ	Programmable Pulse Generator 11 Interrupt (PPG11_PCN:IRQF set depending on PPG11_PCN:IRS[2:0], PPG11_EPCN1:TRIG set when PWM output generation is started, PPG11_EPCN2:[7:0]). See detailed description in FCR4 32-Bit Microcontroller FCR4 Cluster Series Hardware Manual (002-09388).
220	PPG12IRQ	Programmable Pulse Generator 12 Interrupt (PPG12_PCN:IRQF set depending on PPG12_PCN:IRS[2:0], PPG12_EPCN1:TRIG set when PWM output generation is started, PPG12_EPCN2:[7:0]). See detailed description in FCR4 32-Bit Microcontroller FCR4 Cluster Series Hardware Manual (002-09388).
221	PPG13IRQ	Programmable Pulse Generator 13 Interrupt (PPG13_PCN:IRQF set depending on PPG13_PCN:IRS[2:0], PPG13_EPCN1:TRIG set when PWM output generation is started, PPG13_EPCN2:[7:0]). See detailed description in FCR4 32-Bit Microcontroller FCR4 Cluster Series Hardware Manual (002-09388).
222	PPG14IRQ	Programmable Pulse Generator 14 Interrupt (PPG14_PCN:IRQF set depending on PPG14_PCN:IRS[2:0], PPG14_EPCN1:TRIG set when PWM output generation is started, PPG14_EPCN2:[7:0]). See detailed description in FCR4 32-Bit Microcontroller FCR4 Cluster Series Hardware Manual (002-09388).
223	PPG15IRQ	Programmable Pulse Generator 15 Interrupt (PPG15_PCN:IRQF set depending on PPG15_PCN:IRS[2:0], PPG15_EPCN1:TRIG set when PWM output generation is started, PPG15_EPCN2:[7:0]). See detailed description in FCR4 32-Bit Microcontroller FCR4 Cluster Series Hardware Manual (002-09388).
232	PPG64IRQ	Programmable Pulse Generator 64 Interrupt (PPG64_PCN:IRQF set depending on PPG64_PCN:IRS[2:0], PPG64_EPCN1:TRIG set when PWM output generation is started, PPG64_EPCN2:[7:0]). See detailed description in FCR4 32-Bit Microcontroller FCR4 Cluster Series Hardware Manual (002-09388).
233	PPG65IRQ	Programmable Pulse Generator 65 Interrupt (PPG65_PCN:IRQF set depending on PPG65_PCN:IRS[2:0], PPG65_EPCN1:TRIG set when PWM output generation is started, PPG65_EPCN2:[7:0]). See detailed description in FCR4 32-Bit Microcontroller FCR4 Cluster Series Hardware Manual (002-09388).
234	PPG66IRQ	Programmable Pulse Generator 66 Interrupt (PPG66_PCN:IRQF set depending on PPG66_PCN:IRS[2:0], PPG66_EPCN1:TRIG set when PWM output generation is started, PPG66_EPCN2:[7:0]). See detailed description in FCR4 32-Bit Microcontroller FCR4 Cluster Series Hardware Manual (002-09388).
235	PPG67IRQ	Programmable Pulse Generator 67 Interrupt (PPG67_PCN:IRQF set depending on PPG67_PCN:IRS[2:0], PPG67_EPCN1:TRIG set when PWM output generation is started, PPG67_EPCN2:[7:0]). See detailed description in FCR4 32-Bit Microcontroller FCR4 Cluster Series Hardware Manual (002-09388).
236	PPG68IRQ	Programmable Pulse Generator 68 Interrupt (PPG68_PCN:IRQF set depending on PPG68_PCN:IRS[2:0], PPG68_EPCN1:TRIG set when PWM output generation is started, PPG68_EPCN2:[7:0]). See detailed description in FCR4 32-Bit Microcontroller FCR4 Cluster Series Hardware Manual (002-09388).
237	PPG69IRQ	Programmable Pulse Generator 69 Interrupt (PPG69_PCN:IRQF set depending on PPG69_PCN:IRS[2:0], PPG69_EPCN1:TRIG set when PWM output generation is started, PPG69_EPCN2:[7:0]). See detailed description in FCR4 32-Bit Microcontroller FCR4 Cluster Series Hardware Manual (002-09388).

Table 26. Interrupt Table (Continued)

Interrupt Line Number	Interrupt Name	Interrupt Description
238	PPG70IRQ	Programmable Pulse Generator 70 Interrupt (PPG70_PCN:IRQF set depending on PPG70_PCN:IRS[2:0], PPG70_EPCN1:TRIG set when PWM output generation is started, PPG70_EPCN2:[7:0]). See detailed description in FCR4 32-Bit Microcontroller FCR4 Cluster Series Hardware Manual (002-09388).
239	PPG71IRQ	Programmable Pulse Generator 71 Interrupt (PPG71_PCN:IRQF set depending on PPG71_PCN:IRS[2:0], PPG71_EPCN1:TRIG set when PWM output generation is started, PPG71_EPCN2:[7:0]). See detailed description in FCR4 32-Bit Microcontroller FCR4 Cluster Series Hardware Manual (002-09388).

NMI

Table 27. NMI List

NMI Number	Source	Description
0	EIC0NMI	External Pin NMI (EIC0_NMIR:NMIINT)
1	SYSCNMILVD	Low Voltage Detect NMI (check SYSC_SYSERRR:LVD12IF, SYSC_SYSERRR:LVD33IF, SYSC_SY-SERRR:LVD50IF for detailed NMI cause)
2	SYSCNMIERR	System Controller Error NMI (check SYSC_SYSERRR:RUNERRIF, SYSC_SYSERRR:RUNWKERRIF, SYSC_SYSERRR:PSSERRIF, SYSC_SYSERRR:TRGERRIF, SYSC_SYSERRR:RUNTRGEIF, SYSC_SYSERRR:MOMISSIF, SYSC_SYSERRR:SOMISSIF, SYSC_SYSERRR:MPMISSIF, SYSC_SYSERRR:SPMISSIF, SYSC_SYSERRR:GPMISSIF, SYSC_SYSERRR:PSENEIF for detailed NMI cause)
3	WDGNMI	Watchdog NMI (WDG_INT:NMI_FLAG is set on Watchdog error condition if WDG_INT:NMI_EN is '1')
4	TPU0NMI	Timing Protection Unit NMI (check TPU0TIR:IR[7:0] bits for detailed NMI cause) Note The Timing Protection Unit NMI is maskable within the TPU but non-maskable on system level.
5	MPUXDMA0NMI	MPU DMA0 Access Violation NMI (MPUXDMA0_CTRL0:NMI is set when a memory protection violation by DMA0 is detected)
7	MPUXGFXNMI	MPU IRIS-SDL Access Violation NMI(MPUXGFX_CTRL0:NMI is set when a memory protection violation by IRIS-SDL is detected)
8	MPUHMLB0NMI	MPU MLB0 Access Violation NMI(MPUHMLB0_CTRL0:NMI is set when a memory protection violation by MLB0 is detected)
9	IRQ0NMIERR	IRQ Double Error NMI (IRQ0_EEI:EENS bit is set when a double bit error is detected in the IRQ0 Interrupt Vector RAM)
11	BECU0NMI	BECU0 Access Violation NMI (BECU0_CTRL:NMI bit is set when a bus error is detected on the Peripheral Group 0 bus)
12	BECU1NMI	BECU1 Access Violation NMI (BECU1_CTRL:NMI bit is set when a bus error is detected on the Peripheral Group 1 bus)
13	BECU3NMI	BECU3 Access Violation NMI (BECU3_CTRL:NMI bit is set when a bus error is detected on the Peripheral Group 3 bus)
14	GFXNMI	GFX Signature Unit NMI (GFXGCTR_NmiStatus:NmiStatus is set if the number of error frames has exceeded the threshold value)
18	MPUSHE	MPU SHE Access Violation NMI(MPUXSHE0_CTRL0:NMI is set when a memory protection violation by SHE is detected)

DMA Overview

Table 28. Modules with DMA

DMA Request Number	DMA Request Name	DMA Request Description
0	EXTDMA0	External DMA Request 0 (external pin DMA0_DREQ0)
1	EXTDMA1	External DMA Request 1 (external pin DMA0_DREQ0)
8	EIC0DMA0	External Interrupt 0 DMA Request (EIC0_DRFR:DRF0)
9	EIC0DMA1	External Interrupt 1 DMA Request (EIC0_DRFR:DRF1)
10	EIC0DMA2	External Interrupt 2 DMA Request (EIC0_DRFR:DRF2)
11	EIC0DMA3	External Interrupt 3 DMA Request (EIC0_DRFR:DRF3)
12	EIC0DMA4	External Interrupt 4 DMA Request (EIC0_DRFR:DRF4)
13	EIC0DMA5	External Interrupt 5 DMA Request (EIC0_DRFR:DRF5)
14	EIC0DMA6	External Interrupt 6 DMA Request (EIC0_DRFR:DRF6)
15	EIC0DMA7	External Interrupt 7 DMA Request (EIC0_DRFR:DRF7)
16	EIC0DMA8	External Interrupt 8 DMA Request (EIC0_DRFR:DRF8)
17	EIC0DMA9	External Interrupt 9 DMA Request (EIC0_DRFR:DRF9)
18	EIC0DMA10	External Interrupt 10 DMA Request (EIC0_DRFR:DRF10)
19	EIC0DMA11	External Interrupt 11 DMA Request (EIC0_DRFR:DRF11)
20	EIC0DMA12	External Interrupt 12 DMA Request (EIC0_DRFR:DRF12)
21	EIC0DMA13	External Interrupt 13 DMA Request (EIC0_DRFR:DRF13)
22	EIC0DMA14	External Interrupt 14 DMA Request (EIC0_DRFR:DRF14)
23	EIC0DMA15	External Interrupt 15 DMA Request (EIC0_DRFR:DRF15)
24	EIC0DMA16	External Interrupt 16 DMA Request (EIC0_DRFR:DRF16)
25	EIC0DMA17	External Interrupt 17 DMA Request (EIC0_DRFR:DRF17)
26	EIC0DMA18	External Interrupt 18 DMA Request (EIC0_DRFR:DRF18)
27	EIC0DMA19	External Interrupt 19 DMA Request (EIC0_DRFR:DRF19)
28	EIC0DMA20	External Interrupt 20 DMA Request (EIC0_DRFR:DRF20)
29	EIC0DMA21	External Interrupt 21 DMA Request (EIC0_DRFR:DRF21)
30	EIC0DMA22	External Interrupt 22 DMA Request (EIC0_DRFR:DRF22)
31	EIC0DMA23	External Interrupt 23 DMA Request (EIC0_DRFR:DRF23)
32	EIC0DMA24	External Interrupt 24 DMA Request (EIC0_DRFR:DRF24)
33	EIC0DMA25	External Interrupt 25 DMA Request (EIC0_DRFR:DRF25)
34	EIC0DMA26	External Interrupt 26 DMA Request (EIC0_DRFR:DRF26)
35	EIC0DMA27	External Interrupt 27 DMA Request (EIC0_DRFR:DRF27)
36	EIC0DMA28	External Interrupt 28 DMA Request (EIC0_DRFR:DRF28)
37	EIC0DMA29	External Interrupt 29 DMA Request (EIC0_DRFR:DRF29)
38	EIC0DMA30	External Interrupt 30 DMA Request (EIC0_DRFR:DRF30)
39	EIC0DMA31	External Interrupt 31 DMA Request (EIC0_DRFR:DRF31)
40	SG0DMA	Sound Generator 0 DMA Request (SG0_CR1:AMINT* (amplitude match flag) SG0_CR1:TCINT* (tone pulse count match flag) SG0_CR1:ZAIN* (zero amplitude flag))
44	HSSPI0DMARX	HSSPI0 Receive DMA Request (HSSPI0_RXF:RFMTS*(RX FIFO fill level more than threshold))

Table 28. Modules with DMA (Continued)

DMA Request Number	DMA Request Name	DMA Request Description
45	HSSPI0DMATX	HSSPI0 Transmit DMA Request (HSSPI0_TXF:TFLETS* (TX FIFO fill level less or equal to threshold))
48	FRT0DMA	Free Running Timer 0 DMA Request (FRT0_TCCS:IVF* (compare clear flag); FRT0_ETCCS:IRQZF* (zero detect flag))
49	FRT1DMA	Free Running Timer 1 DMA Request (FRT1_TCCS:IVF* (compare clear flag); FRT1_ETCCS:IRQZF* (zero detect flag))
50	FRT2DMA	Free Running Timer 2 DMA Request (FRT2_TCCS:IVF* (compare clear flag); FRT2_ETCCS:IRQZF* (zero detect flag))
51	FRT3DMA	Free Running Timer 3 DMA Request (FRT3_TCCS:IVF* (compare clear flag); FRT3_ETCCS:IRQZF* (zero detect flag))
64	FRT16DMA	Free Running Timer 16 DMA Request (FRT16_TCCS:IVF* (compare clear flag); FRT16_ETCCS:IRQZF* (zero detect flag))
65	FRT17DMA	Free Running Timer 17 DMA Request (FRT17_TCCS:IVF* (compare clear flag); FRT17_ETCCS:IRQZF* (zero detect flag))
66	FRT18DMA	Free Running Timer 18 DMA Request (FRT18_TCCS:IVF* (compare clear flag); FRT18_ETCCS:IRQZF* (zero detect flag))
67	FRT19DMA	Free Running Timer 19 DMA Request (FRT19_TCCS:IVF* (compare clear flag); FRT19_ETCCS:IRQZF* (zero detect flag))
84	ICU2DMA0	Input Capture Unit 2 channel 0 DMA Request (ICU2_ICEICS01:ICP0*)
85	ICU2DMA1	Input Capture Unit 2 channel 1 DMA Request (ICU2_ICEICS01:ICP1*)
86	ICU3DMA0	Input Capture Unit 3 channel 0 DMA Request (ICU2_ICEICS01:ICP0*)
87	ICU3DMA1	Input Capture Unit 3 channel 1 DMA Request (ICU2_ICEICS01:ICP1*)
116	ICU18DMA0	Input Capture Unit 18 channel 0 DMA Request (ICU18_ICEICS01:ICP0*)
117	ICU18DMA1	Input Capture Unit 18 channel 1 DMA Request (ICU18_ICEICS01:ICP1*)
118	ICU19DMA0	Input Capture Unit 19 channel 0 DMA Request (ICU19_ICEICS01:ICP0*)
119	ICU19DMA1	Input Capture Unit 19 channel 1 DMA Request (ICU19_ICEICS01:ICP1*)
144	OCU0DMA0	Output Compare Unit 0 channel 0 DMA Request (OCU0_OSR01:ICP0*)
145	OCU0DMA1	Output Compare Unit 0 channel 1 DMA Request (OCU0_OSR01:ICP1*)
146	OCU1DMA0	Output Compare Unit 1 channel 0 DMA Request (OCU1_OSR01:ICP0*)
147	OCU1DMA1	Output Compare Unit 1 channel 1 DMA Request (OCU1_OSR01:ICP1*)
176	OCU16DMA0	Output Compare Unit 16 channel 0 DMA Request (OCU16_OSR01:ICP0*)
177	OCU16DMA1	Output Compare Unit 16 channel 1 DMA Request (OCU16_OSR01:ICP1*)
178	OCU17DMA0	Output Compare Unit 17 channel 0 DMA Request (OCU17_OSR01:ICP0*)
179	OCU17DMA1	Output Compare Unit 17 channel 1 DMA Request (OCU17_OSR01:ICP1*)
208	USART0DMARX	LIN USART 0 Receive DMA Request (USART0_SSR:RDRF* (RX data full flag))

Table 28. Modules with DMA (Continued)

DMA Request Number	DMA Request Name	DMA Request Description
209	USART0DMATX	LIN USART 0 Transmit DMA Request (USART0_SSR:TDRE* (TX data empty flag))
220	USART6DMARX	LIN USART 6 Receive DMA Request (USART6_SSR:RDRF* (RX data full flag))
221	USART6DMATX	LIN USART 6 Transmit DMA Request (USART6_SSR:TDRE* (TX data empty flag))
232	I2C0DMARX	I2C0 Receive DMA Request (I2C0_IBCSR:INT*)
233	I2C0DMATX	I2C0 Transmit DMA Request (I2C0_IBCSR:INT*)
244	PPG0DMA	Programmable Pulse Generator 0 DMA Request (PPG0_PCN:IRQF*)
245	PPG1DMA	Programmable Pulse Generator 1 DMA Request (PPG1_PCN:IRQF*)
246	PPG2DMA	Programmable Pulse Generator 2 DMA Request (PPG2_PCN:IRQF*)
247	PPG3DMA	Programmable Pulse Generator 3 DMA Request (PPG3_PCN:IRQF*)
248	PPG4DMA	Programmable Pulse Generator 4 DMA Request (PPG4_PCN:IRQF*)
249	PPG5DMA	Programmable Pulse Generator 5 DMA Request (PPG5_PCN:IRQF*)
250	PPG6DMA	Programmable Pulse Generator 6 DMA Request (PPG6_PCN:IRQF*)
251	PPG7DMA	Programmable Pulse Generator 7 DMA Request (PPG7_PCN:IRQF*)
252	PPG8DMA	Programmable Pulse Generator 8 DMA Request (PPG8_PCN:IRQF*)
253	PPG9DMA	Programmable Pulse Generator 9 DMA Request (PPG9_PCN:IRQF*)
254	PPG10DMA	Programmable Pulse Generator 10 DMA Request (PPG10_PCN:IRQF*)
255	PPG11DMA	Programmable Pulse Generator 11 DMA Request (PPG11_PCN:IRQF*)
256	PPG12DMA	Programmable Pulse Generator 12 DMA Request (PPG12_PCN:IRQF*)
257	PPG13DMA	Programmable Pulse Generator 13 DMA Request (PPG13_PCN:IRQF*)
258	PPG14DMA	Programmable Pulse Generator 14 DMA Request (PPG14_PCN:IRQF*)
259	PPG15DMA	Programmable Pulse Generator 15 DMA Request (PPG15_PCN:IRQF*)
308	PPG64DMA	Programmable Pulse Generator 64 DMA Request (PPG64_PCN:IRQF*)
309	PPG65DMA	Programmable Pulse Generator 65 DMA Request (PPG65_PCN:IRQF*)
310	PPG66DMA	Programmable Pulse Generator 66 DMA Request (PPG66_PCN:IRQF*)
311	PPG67DMA	Programmable Pulse Generator 67 DMA Request (PPG67_PCN:IRQF*)
312	PPG68DMA	Programmable Pulse Generator 68 DMA Request (PPG68_PCN:IRQF*)
313	PPG69DMA	Programmable Pulse Generator 69 DMA Request (PPG69_PCN:IRQF*)
314	PPG70DMA	Programmable Pulse Generator 70 DMA Request (PPG70_PCN:IRQF*)
315	PPG71DMA	Programmable Pulse Generator 71 DMA Request (PPG71_PCN:IRQF*)
372	ADC0DMA	ADC0 Conversion End DMA Request (ADC0_CS1:INT* (end of conversion flag))
373	ADC0DMA2	ADC0 Scan End DMA Request (ADC0_CS3:INT2* (end of scan flag))
376	RLT0DMA	Reload Timer 0 DMA Request (RTL0_TMCSR:UF* (underflow flag))
377	RLT1DMA	Reload Timer 1 DMA Request (RTL1_TMCSR:UF* (underflow flag))
378	RLT2DMA	Reload Timer 2 DMA Request (RTL2_TMCSR:UF* (underflow flag))
379	RLT3DMA	Reload Timer 3 DMA Request (RTL3_TMCSR:UF* (underflow flag))
380	RLT4DMA	Reload Timer 4 DMA Request (RTL4_TMCSR:UF* (underflow flag))
381	RLT5DMA	Reload Timer 5 DMA Request (RTL5_TMCSR:UF* (underflow flag))
382	RLT6DMA	Reload Timer 6 DMA Request (RTL6_TMCSR:UF* (underflow flag))
383	RLT7DMA	Reload Timer 7 DMA Request (RTL7_TMCSR:UF* (underflow flag))
384	RLT8DMA	Reload Timer 8 DMA Request (RTL8_TMCSR:UF* (underflow flag))

Table 28. Modules with DMA (Continued)

DMA Request Number	DMA Request Name	DMA Request Description
385	RLT9DMA	Reload Timer 9 DMA Request (RTL9_TMCSR:UF* (underflow flag))
408	I2S0DMARX	I2S0 Receive DMA Request (I2S0_STATUS:RXFI* (receive FIFO full))
409	I2S0DMATX	I2S0 Transmit DMA Request (I2S0_STATUS:TXFI* (transmit FIFO empty))
410	I2S1DMARX	I2S0 Receive DMA Request (I2S1_STATUS:RXFI* (receive FIFO full))
411	I2S1DMATX	I2S0 Transmit DMA Request (I2S1_STATUS:TXFI* (transmit FIFO empty))
424	CRC0DMA	CRC0 DMA Request (CRC0_CFG:CIRQ* (CRC calculated flag))
426	SPI0DMARX	SPI0 Receive DMA Request (SPI0_RXF:RFMTS* (RX FIFO fill level more than threshold))
427	SPI0DMATX	SPI0 Transmit DMA Request (SPI0_TXF:TFLETS* (TX FIFO fill level less or equal to threshold))
428	SPI1DMARX	SPI1 Receive DMA Request (SPI1_RXF:RFMTS* (RX FIFO fill level more than threshold))
429	SPI1DMATX	SPI1 Transmit DMA Request (SPI1_TXF:TFLETS* (TX FIFO fill level less or equal to threshold))
430	SPI2DMARX	SPI2 Receive DMA Request (SPI2_RXF:RFMTS* (RX FIFO fill level more than threshold))
431	SPI2DMATX	SPI2 Transmit DMA Request (SPI2_TXF:TFLETS* (TX FIFO fill level less or equal to threshold))
450	EEFLASHDMA	EE Flash DMA Request (EEFCFG_WSR:ST[1:0])
467	PPUDMA	PPU DMA Request (DMA is triggered by successful PPU UNLOCK (PPU0_UNLOCK) indicated by PPU0_ST:LST = 0)

PPU

Table 29. List of PPU Channels

	31	30	29	28	27	26	25	24	23	22	21	20	19	18	17	16	15	14	13	12	11	10	9	8	7	6	5	4	3	2	1	0
PPU0_PA0 PPU0_PR0	-	-	-	-	-	-	-	-	-	-	-	-	-	-	-	-	-	-	-	-	-	-	-	-	-	-	-	-	-	-	-	-
PPU0_PA1 PPU0_PR1	-	-	-	-	-	-	-	-	-	-	-	-	-	-	-	-	-	-	-	-	-	-	-	-	-	-	-	-	-	-	-	-
PPU0_PA2 PPU0_PR2	-	-	-	-	-	-	-	-	-	-	-	-	-	-	-	SG0	-	-	-	-	-	-	-	-	-	SMCTG0	SMC5	SMC4	SMC3	SMC2	SMC1	SMC0
PPU0_PA3 PPU0_PR3	-	-	-	-	-	-	-	UDC0	-	-	-	-	-	-	I2S1	I2S0	-	-	-	-	-	-	-	I2C0	-	-	-	-	-	-	-	ADC0
PPU0_PA4 PPU0_PR4	-	SHE	-	MLB0	-	-	-	-	-	-	-	-	-	-	-	HSSP10	-	-	-	-	-	-	-	-	-	-	-	-	SPI2	SPI1	SPI0	-
PPU0_PA5 PPU0_PR5	-	-	-	-	-	-	-	-	-	-	-	-	-	CAN1	CAN0	-	-	-	-	-	-	-	-	-	-	USART6	-	-	-	-	-	USART0
PPU0_PA6 PPU0_PR6	-	-	-	-	-	-	-	-	-	-	-	-	-	-	-	-	-	-	-	-	-	RLT9	RLT8	RLT7	RLT6	RLT5	RLT4	RLT3	RLT2	RLT1	RLT0	
PPU0_PA7 PPU0_PR7	-	-	-	-	-	-	-	-	-	-	-	-	FRT19	FRT18	FRT17	FRT16	-	-	-	-	-	-	-	-	-	-	-	FRT3	FRT2	FRT1	FRT0	
PPU0_PA8 PPU0_PR8	-	-	-	-	-	-	-	-	-	-	-	-	ICU19	ICU18	-	-	-	-	-	-	-	-	-	-	-	-	-	ICU3	ICU2	-	-	
PPU0_PA9 PPU0_PR9	-	-	-	-	-	-	-	-	-	-	-	-	-	-	OCU17	OCU16	-	-	-	-	-	-	-	-	-	-	-	-	-	OCU1	OCU0	
PPU0_PA10 PPU0_PR10	PPGGLC1	PPGGLC0	EEFCFG	RTC	-	EICU0	-	CRC0	-	-	-	-	-	-	-	-	-	-	-	-	-	GFXCFG	GFXVRAM	GFXSPIMEM	SRCSCCT	RCSCCT	SSCT	MSCT	WDG	DBG0	PPCPRIV	PPCUSER
PPU0_PA11 PPU0_PR11	-	-	-	-	-	-	-	-	-	-	-	-	-	-	PPGGRP17	PPGGRP16	-	-	-	-	-	-	-	-	-	-	-	-	-	-	-	-
PPU0_PA12 PPU0_PR12	-	-	-	-	-	-	-	-	-	-	-	-	-	-	-	PPG15	PPG14	PPG13	PPG12	PPG11	PPG10	PPG9	PPG8	PPG7	PPG6	PPG5	PPG4	PPG3	PPG2	PPG1	PPG0	
PPU0_PA13 PPU0_PR13	-	-	-	-	-	-	-	-	-	-	-	-	-	-	-	-	-	-	-	-	-	-	-	PPG71	PPG70	PPG69	PPG68	PPG67	PPG66	PPG65	PPG64	
PPU0_PA14 PPU0_PR14	-	-	-	-	-	-	-	-	-	-	-	-	-	-	-	-	-	-	-	-	-	-	-	-	-	-	-	-	-	-	-	-
PPU0_PA15 PPU0_PR15	-	-	-	-	-	-	-	-	-	-	-	-	-	-	-	-	-	-	-	-	-	-	-	-	-	-	-	-	-	-	-	-

Note

- In general, a PPU channel controls the access in user mode to the corresponding peripheral. However, there are a few exceptions:
 - PPCPRIV controls the access to PPC in privileged mode.
 - PPCUSER controls the access to PPC in user mode.
 - MSCT, SSCT, RCSCCT and SRCSCCT control the access to the source clock timers within the System Controller, i.e. the registers SYSC_MSCT*, SYSC_SSCT*, SYSC_RCSCCT* and SYSC_SRCSCCT, after the corresponding source clock stabilization time has elapsed
 - WDG controls the write access in user mode to the Watchdog trigger registers, so WDG has no read attribute
 - Read attribute for DBG0 is always enabled. Even privilege mode access for DBG0 needs PPU to be enabled.

Master ID

Table 30. List of Master IDs used on CY9EF226 Device

Master Name	Master ID (USER Signal Values)
CPU_S0	0x04
DMA_SI	0x08
DAP_AHB	0x01
TIC_AHB	0x00
MLB0_AHB	0x02
SUBSYS (IRIS-SDL)	0x0C
SHE	0x10

I/O Map

Table 31. Memory Layout of HSSPI0 Registers with Default Values

Offset	+3	+2	+1	+0
0xB0000000	HSSPI0_MCTRL 00000000 00000000 00000000 00000000			
0xB0000004	HSSPI0_PCC0 00000000 00000001 00000000 00000000			
0xB0000008	HSSPI0_PCC1 00000000 00000001 00000000 00000000			
0xB000000C	HSSPI0_PCC2 00000000 00000001 00000000 00000000			
0xB0000010	HSSPI0_PCC3 00000000 00000001 00000000 00000000			
0xB0000014	HSSPI0_TXF 00000000 00000000 00000000 00000000			
0xB0000018	HSSPI0_TXE 00000000 00000000 00000000 00000000			
0xB000001C	HSSPI0_TXC 00000000 00000000 00000000 00000000			
0xB0000020	HSSPI0_RXF 00000000 00000000 00000000 00000000			
0xB0000024	HSSPI0_RXE 00000000 00000000 00000000 00000000			
0xB0000028	HSSPI0_RXC 00000000 00000000 00000000 00000000			
0xB000002C	HSSPI0_FAULTF 00000000 00000000 00000000 00000000			
0xB0000030	HSSPI0_FAULTC 00000000 00000000 00000000 00000000			
0xB0000034	read0 00000000 00000000		HSSPI0_DMDMAEN 00000000	HSSPI0_DMCFG 00000001
0xB0000038	HSSPI0_DMTRP 00000000	HSSPI0_DMPSEL 00000000	HSSPI0_DMSTOP 00000000	HSSPI0_DMSTART 00000000
0xB000003C	HSSPI0_DMBCS 00000000 00000000		HSSPI0_DMBCB 00000000 00000000	
0xB0000040	HSSPI0_DMSTATUS 00000000 00000000 00000000 00000000			
0xB0000044	read0 00000000 00000000		HSSPI0_RXBITCNT 00000000	HSSPI0_TXBITCNT 00000000
0xB0000048	HSSPI0_RXSHIFT 00000000 00000000 00000000 00000000			

Table 31. Memory Layout of HSSPI0 Registers with Default Values (Continued)

Offset	+3	+2	+1	+0
0xB000004C		HSSPI0_FIFOCFG 00000000 00000000 00000000 01110111		
0xB0000050		HSSPI0_TXFIFO0 00000000 00000000 00000000 00000000		
0xB0000054		HSSPI0_TXFIFO1 00000000 00000000 00000000 00000000		
0xB0000058		HSSPI0_TXFIFO2 00000000 00000000 00000000 00000000		
0xB000005C		HSSPI0_TXFIFO3 00000000 00000000 00000000 00000000		
0xB0000060		HSSPI0_TXFIFO4 00000000 00000000 00000000 00000000		
0xB0000064		HSSPI0_TXFIFO5 00000000 00000000 00000000 00000000		
0xB0000068		HSSPI0_TXFIFO6 00000000 00000000 00000000 00000000		
0xB000006C		HSSPI0_TXFIFO7 00000000 00000000 00000000 00000000		
0xB0000070		HSSPI0_TXFIFO8 00000000 00000000 00000000 00000000		
0xB0000074		HSSPI0_TXFIFO9 00000000 00000000 00000000 00000000		
0xB0000078		HSSPI0_TXFIFO10 00000000 00000000 00000000 00000000		
0xB000007C		HSSPI0_TXFIFO11 00000000 00000000 00000000 00000000		
0xB0000080		HSSPI0_TXFIFO12 00000000 00000000 00000000 00000000		
0xB0000084		HSSPI0_TXFIFO13 00000000 00000000 00000000 00000000		
0xB0000088		HSSPI0_TXFIFO14 00000000 00000000 00000000 00000000		
0xB000008C		HSSPI0_TXFIFO15 00000000 00000000 00000000 00000000		
0xB0000090		HSSPI0_RXFIFO0 00000000 00000000 00000000 00000000		
0xB0000094		HSSPI0_RXFIFO1 00000000 00000000 00000000 00000000		
0xB0000098		HSSPI0_RXFIFO2 00000000 00000000 00000000 00000000		
0xB000009C		HSSPI0_RXFIFO3 00000000 00000000 00000000 00000000		
0xB00000A0		HSSPI0_RXFIFO4 00000000 00000000 00000000 00000000		
0xB00000A4		HSSPI0_RXFIFO5 00000000 00000000 00000000 00000000		
0xB00000A8		HSSPI0_RXFIFO6 00000000 00000000 00000000 00000000		
0xB00000AC		HSSPI0_RXFIFO7 00000000 00000000 00000000 00000000		
0xB00000B0		HSSPI0_RXFIFO8 00000000 00000000 00000000 00000000		

Table 31. Memory Layout of HSSPI0 Registers with Default Values (Continued)

Offset	+3	+2	+1	+0
0xB00000B4	HSSPI0_RXFIFO9 00000000 00000000 00000000 00000000			
0xB00000B8	HSSPI0_RXFIFO10 00000000 00000000 00000000 00000000			
0xB00000BC	HSSPI0_RXFIFO11 00000000 00000000 00000000 00000000			
0xB00000C0	HSSPI0_RXFIFO12 00000000 00000000 00000000 00000000			
0xB00000C4	HSSPI0_RXFIFO13 00000000 00000000 00000000 00000000			
0xB00000C8	HSSPI0_RXFIFO14 00000000 00000000 00000000 00000000			
0xB00000CC	HSSPI0_RXFIFO15 00000000 00000000 00000000 00000000			
0xB00000D0	HSSPI0_CSCFG 00000000 00000000 00000000 00000000			
0xB00000D4	HSSPI0_CSITIME 00000000 00000000 11111111 11111111			
0xB00000D8	HSSPI0_CSAEXT 00000000 00000000 00000000 00000000			
0xB00000DC	HSSPI0_RDCSDC1 00000000 00000000		HSSPI0_RDCSDC0 00000000 00000000	
0xB00000E0	HSSPI0_RDCSDC3 00000000 00000000		HSSPI0_RDCSDC2 00000000 00000000	
0xB00000E4	HSSPI0_RDCSDC5 00000000 00000000		HSSPI0_RDCSDC4 00000000 00000000	
0xB00000E8	HSSPI0_RDCSDC7 00000000 00000000		HSSPI0_RDCSDC6 00000000 00000000	
0xB00000EC	HSSPI0_WRCSDC1 00000000 00000000		HSSPI0_WRCSDC0 00000000 00000000	
0xB00000F0	HSSPI0_WRCSDC3 00000000 00000000		HSSPI0_WRCSDC2 00000000 00000000	
0xB00000F4	HSSPI0_WRCSDC5 00000000 00000000		HSSPI0_WRCSDC4 00000000 00000000	
0xB00000F8	HSSPI0_WRCSDC7 00000000 00000000		HSSPI0_WRCSDC6 00000000 00000000	
0xB00000FC	HSSPI0_MID 00000000 00000000 00000000 00000001			
0xB0000100- B0077FFC	reserved XXXXXXXX XXXXXXXX XXXXXXXX XXXXXXXX			
0xB0078000	read0 00000000 00000000		RCFG8_HSSPI0MSTART 00000000 00000000	
0xB0078004- B007FC00	reserved XXXXXXXX XXXXXXXX XXXXXXXX XXXXXXXX			
0xB007FC04	BSU8_BTST 00000000 00000000 00000000 00000000			
0xB007FC08- B007FC0C	reserved XXXXXXXX XXXXXXXX XXXXXXXX XXXXXXXX			
0xB007FC10	BSU8_PEN0 00000000 00000000 00000000 00000000			
0xB007FC14- B007FFFC	reserved XXXXXXXX XXXXXXXX XXXXXXXX XXXXXXXX			

Table 32. Memory Layout of MEMORY_CONFIG Registers with Default Values

Offset	+7	+6	+5	+4	+3	+2	+1	+0
0xB0400000	IRQ0_NMIST 00000000 00000000 00001111 00100000				IRQ0_NMIVAS 00000000 00000000 00000000 00000000			
0xB0400008	IRQ0_IRQST 00000000 00001111 00000010 00000000				IRQ0_IRQVAS 00000000 00000000 00000000 00000000			
0xB0400010	IRQ0_NMIVA1 XXXXXXXX XXXXXXXX XXXXXXXX XXXXXX00				IRQ0_NMIVA0 XXXXXXXX XXXXXXXX XXXXXXXX XXXXXX00			
0xB0400018	IRQ0_NMIVA3 XXXXXXXX XXXXXXXX XXXXXXXX XXXXXX00				IRQ0_NMIVA2 XXXXXXXX XXXXXXXX XXXXXXXX XXXXXX00			
0xB0400020	IRQ0_NMIVA5 XXXXXXXX XXXXXXXX XXXXXXXX XXXXXX00				IRQ0_NMIVA4 XXXXXXXX XXXXXXXX XXXXXXXX XXXXXX00			
0xB0400028	IRQ0_NMIVA7 XXXXXXXX XXXXXXXX XXXXXXXX XXXXXX00				reserved XXXXXXXX XXXXXXXX XXXXXXXX XXXXXXXX			
0xB0400030	IRQ0_NMIVA9 XXXXXXXX XXXXXXXX XXXXXXXX XXXXXX00				IRQ0_NMIVA8 XXXXXXXX XXXXXXXX XXXXXXXX XXXXXX00			
0xB0400038	IRQ0_NMIVA11 XXXXXXXX XXXXXXXX XXXXXXXX XXXXXX00				reserved XXXXXXXX XXXXXXXX XXXXXXXX XXXXXXXX			
0xB0400040	IRQ0_NMIVA13 XXXXXXXX XXXXXXXX XXXXXXXX XXXXXX00				IRQ0_NMIVA12 XXXXXXXX XXXXXXXX XXXXXXXX XXXXXX00			
0xB0400048	reserved XXXXXXXX XXXXXXXX XXXXXXXX XXXXXXXX				IRQ0_NMIVA14 XXXXXXXX XXXXXXXX XXXXXXXX XXXXXX00			
0xB0400050	reserved XXXXXXXX XXXXXXXX XXXXXXXX XXXXXXXX				reserved XXXXXXXX XXXXXXXX XXXXXXXX XXXXXXXX			
0xB0400058	reserved XXXXXXXX XXXXXXXX XXXXXXXX XXXXXXXX				IRQ0_NMIVA18 XXXXXXXX XXXXXXXX XXXXXXXX XXXXXX00			
0xB0400060	reserved XXXXXXXX XXXXXXXX XXXXXXXX XXXXXXXX				reserved XXXXXXXX XXXXXXXX XXXXXXXX XXXXXXXX			
0xB0400068	reserved XXXXXXXX XXXXXXXX XXXXXXXX XXXXXXXX				reserved XXXXXXXX XXXXXXXX XXXXXXXX XXXXXXXX			
0xB0400070	reserved XXXXXXXX XXXXXXXX XXXXXXXX XXXXXXXX				reserved XXXXXXXX XXXXXXXX XXXXXXXX XXXXXXXX			
0xB0400078	reserved XXXXXXXX XXXXXXXX XXXXXXXX XXXXXXXX				reserved XXXXXXXX XXXXXXXX XXXXXXXX XXXXXXXX			
0xB0400080	reserved XXXXXXXX XXXXXXXX XXXXXXXX XXXXXXXX				reserved XXXXXXXX XXXXXXXX XXXXXXXX XXXXXXXX			
0xB0400088	reserved XXXXXXXX XXXXXXXX XXXXXXXX XXXXXXXX				reserved XXXXXXXX XXXXXXXX XXXXXXXX XXXXXXXX			
0xB0400090	IRQ0_IRQVA1 XXXXXXXX XXXXXXXX XXXXXXXX XXXXXX00				IRQ0_IRQVA0 XXXXXXXX XXXXXXXX XXXXXXXX XXXXXX00			
0xB0400098	reserved XXXXXXXX XXXXXXXX XXXXXXXX XXXXXXXX				reserved XXXXXXXX XXXXXXXX XXXXXXXX XXXXXXXX			
0xB04000A0	reserved XXXXXXXX XXXXXXXX XXXXXXXX XXXXXXXX				reserved XXXXXXXX XXXXXXXX XXXXXXXX XXXXXXXX			
0xB04000A8	reserved XXXXXXXX XXXXXXXX XXXXXXXX XXXXXXXX				reserved XXXXXXXX XXXXXXXX XXXXXXXX XXXXXXXX			
0xB04000B0	reserved XXXXXXXX XXXXXXXX XXXXXXXX XXXXXXXX				reserved XXXXXXXX XXXXXXXX XXXXXXXX XXXXXXXX			
0xB04000B8	reserved XXXXXXXX XXXXXXXX XXXXXXXX XXXXXXXX				reserved XXXXXXXX XXXXXXXX XXXXXXXX XXXXXXXX			
0xB04000C0	reserved XXXXXXXX XXXXXXXX XXXXXXXX XXXXXXXX				reserved XXXXXXXX XXXXXXXX XXXXXXXX XXXXXXXX			

Table 32. Memory Layout of MEMORY_CONFIG Registers with Default Values (Continued)

Offset	+7	+6	+5	+4	+3	+2	+1	+0
0xB04000C8	IRQ0_IRQVA15 XXXXXXXX XXXXXXXX XXXXXXXX XXXXXX00				reserved XXXXXXXX XXXXXXXX XXXXXXXX XXXXXXXX			
0xB04000D0	reserved XXXXXXXX XXXXXXXX XXXXXXXX XXXXXXXX				IRQ0_IRQVA16 XXXXXXXX XXXXXXXX XXXXXXXX XXXXXXX0			
0xB04000D8	reserved XXXXXXXX XXXXXXXX XXXXXXXX XXXXXXXX				reserved XXXXXXXX XXXXXXXX XXXXXXXX XXXXXXXX			
0xB04000E0	reserved XXXXXXXX XXXXXXXX XXXXXXXX XXXXXXXX				reserved XXXXXXXX XXXXXXXX XXXXXXXX XXXXXXXX			
0xB04000E8	IRQ0_IRQVA23 XXXXXXXX XXXXXXXX XXXXXXXX XXXXXX00				IRQ0_IRQVA22 XXXXXXXX XXXXXXXX XXXXXXXX XXXXXXX0			
0xB04000F0	reserved XXXXXXXX XXXXXXXX XXXXXXXX XXXXXXXX				reserved XXXXXXXX XXXXXXXX XXXXXXXX XXXXXXXX			
0xB04000F8	reserved XXXXXXXX XXXXXXXX XXXXXXXX XXXXXXXX				reserved XXXXXXXX XXXXXXXX XXXXXXXX XXXXXXXX			
0xB0400100	reserved XXXXXXXX XXXXXXXX XXXXXXXX XXXXXXXX				reserved XXXXXXXX XXXXXXXX XXXXXXXX XXXXXXXX			
0xB0400108	IRQ0_IRQVA31 XXXXXXXX XXXXXXXX XXXXXXXX XXXXXX00				IRQ0_IRQVA30 XXXXXXXX XXXXXXXX XXXXXXXX XXXXXXX0			
0xB0400110	IRQ0_IRQVA33 XXXXXXXX XXXXXXXX XXXXXXXX XXXXXX00				IRQ0_IRQVA32 XXXXXXXX XXXXXXXX XXXXXXXX XXXXXXX0			
0xB0400118	IRQ0_IRQVA35 XXXXXXXX XXXXXXXX XXXXXXXX XXXXXX00				IRQ0_IRQVA34 XXXXXXXX XXXXXXXX XXXXXXXX XXXXXXX0			
0xB0400120	IRQ0_IRQVA37 XXXXXXXX XXXXXXXX XXXXXXXX XXXXXX00				IRQ0_IRQVA36 XXXXXXXX XXXXXXXX XXXXXXXX XXXXXXX0			
0xB0400128	reserved XXXXXXXX XXXXXXXX XXXXXXXX XXXXXXXX				IRQ0_IRQVA38 XXXXXXXX XXXXXXXX XXXXXXXX XXXXXXX0			
0xB0400130	IRQ0_IRQVA41 XXXXXXXX XXXXXXXX XXXXXXXX XXXXXX00				IRQ0_IRQVA40 XXXXXXXX XXXXXXXX XXXXXXXX XXXXXXX0			
0xB0400138	IRQ0_IRQVA43 XXXXXXXX XXXXXXXX XXXXXXXX XXXXXX00				IRQ0_IRQVA42 XXXXXXXX XXXXXXXX XXXXXXXX XXXXXXX0			
0xB0400140	IRQ0_IRQVA45 XXXXXXXX XXXXXXXX XXXXXXXX XXXXXX00				IRQ0_IRQVA44 XXXXXXXX XXXXXXXX XXXXXXXX XXXXXXX0			
0xB0400148	reserved XXXXXXXX XXXXXXXX XXXXXXXX XXXXXXXX				reserved XXXXXXXX XXXXXXXX XXXXXXXX XXXXXXXX			
0xB0400150	IRQ0_IRQVA49 XXXXXXXX XXXXXXXX XXXXXXXX XXXXXX00				IRQ0_IRQVA48 XXXXXXXX XXXXXXXX XXXXXXXX XXXXXXX0			
0xB0400158	reserved XXXXXXXX XXXXXXXX XXXXXXXX XXXXXXXX				IRQ0_IRQVA50 XXXXXXXX XXXXXXXX XXXXXXXX XXXXXXX0			
0xB0400160	IRQ0_IRQVA53 XXXXXXXX XXXXXXXX XXXXXXXX XXXXXX00				IRQ0_IRQVA52 XXXXXXXX XXXXXXXX XXXXXXXX XXXXXXX0			
0xB0400168	IRQ0_IRQVA55 XXXXXXXX XXXXXXXX XXXXXXXX XXXXXX00				reserved XXXXXXXX XXXXXXXX XXXXXXXX XXXXXXXX			
0xB0400170	reserved XXXXXXXX XXXXXXXX XXXXXXXX XXXXXXXX				IRQ0_IRQVA56 XXXXXXXX XXXXXXXX XXXXXXXX XXXXXXX0			
0xB0400178	reserved XXXXXXXX XXXXXXXX XXXXXXXX XXXXXXXX				reserved XXXXXXXX XXXXXXXX XXXXXXXX XXXXXXXX			
0xB0400180	IRQ0_IRQVA61 XXXXXXXX XXXXXXXX XXXXXXXX XXXXXX00				reserved XXXXXXXX XXXXXXXX XXXXXXXX XXXXXXXX			
0xB0400188	reserved XXXXXXXX XXXXXXXX XXXXXXXX XXXXXXXX				IRQ0_IRQVA62 XXXXXXXX XXXXXXXX XXXXXXXX XXXXXXX0			

Table 32. Memory Layout of MEMORY_CONFIG Registers with Default Values (Continued)

Offset	+7	+6	+5	+4	+3	+2	+1	+0
0xB0400190	reserved XXXXXXXX XXXXXXXX XXXXXXXX XXXXXXXX				reserved XXXXXXXX XXXXXXXX XXXXXXXX XXXXXXXX			
0xB0400198	reserved XXXXXXXX XXXXXXXX XXXXXXXX XXXXXXXX				reserved XXXXXXXX XXXXXXXX XXXXXXXX XXXXXXXX			
0xB04001A0	IRQ0_IRQVA69 XXXXXXXX XXXXXXXX XXXXXXXX XXXXXXX0				reserved XXXXXXXX XXXXXXXX XXXXXXXX XXXXXXXX			
0xB04001A8	IRQ0_IRQVA71 XXXXXXXX XXXXXXXX XXXXXXXX XXXXXXX0				IRQ0_IRQVA70 XXXXXXXX XXXXXXXX XXXXXXXX XXXXXXX0			
0xB04001B0	IRQ0_IRQVA73 XXXXXXXX XXXXXXXX XXXXXXXX XXXXXXX0				IRQ0_IRQVA72 XXXXXXXX XXXXXXXX XXXXXXXX XXXXXXX0			
0xB04001B8	IRQ0_IRQVA75 XXXXXXXX XXXXXXXX XXXXXXXX XXXXXXX0				IRQ0_IRQVA74 XXXXXXXX XXXXXXXX XXXXXXXX XXXXXXX0			
0xB04001C0	IRQ0_IRQVA77 XXXXXXXX XXXXXXXX XXXXXXXX XXXXXXX0				IRQ0_IRQVA76 XXXXXXXX XXXXXXXX XXXXXXXX XXXXXXX0			
0xB04001C8	IRQ0_IRQVA79 XXXXXXXX XXXXXXXX XXXXXXXX XXXXXXX0				IRQ0_IRQVA78 XXXXXXXX XXXXXXXX XXXXXXXX XXXXXXX0			
0xB04001D0	IRQ0_IRQVA81 XXXXXXXX XXXXXXXX XXXXXXXX XXXXXXX0				IRQ0_IRQVA80 XXXXXXXX XXXXXXXX XXXXXXXX XXXXXXX0			
0xB04001D8	IRQ0_IRQVA83 XXXXXXXX XXXXXXXX XXXXXXXX XXXXXXX0				IRQ0_IRQVA82 XXXXXXXX XXXXXXXX XXXXXXXX XXXXXXX0			
0xB04001E0	IRQ0_IRQVA85 XXXXXXXX XXXXXXXX XXXXXXXX XXXXXXX0				IRQ0_IRQVA84 XXXXXXXX XXXXXXXX XXXXXXXX XXXXXXX0			
0xB04001E8	IRQ0_IRQVA87 XXXXXXXX XXXXXXXX XXXXXXXX XXXXXXX0				IRQ0_IRQVA86 XXXXXXXX XXXXXXXX XXXXXXXX XXXXXXX0			
0xB04001F0	IRQ0_IRQVA89 XXXXXXXX XXXXXXXX XXXXXXXX XXXXXXX0				IRQ0_IRQVA88 XXXXXXXX XXXXXXXX XXXXXXXX XXXXXXX0			
0xB04001F8	IRQ0_IRQVA91 XXXXXXXX XXXXXXXX XXXXXXXX XXXXXXX0				IRQ0_IRQVA90 XXXXXXXX XXXXXXXX XXXXXXXX XXXXXXX0			
0xB0400200	IRQ0_IRQVA93 XXXXXXXX XXXXXXXX XXXXXXXX XXXXXXX0				IRQ0_IRQVA92 XXXXXXXX XXXXXXXX XXXXXXXX XXXXXXX0			
0xB0400208	IRQ0_IRQVA95 XXXXXXXX XXXXXXXX XXXXXXXX XXXXXXX0				IRQ0_IRQVA94 XXXXXXXX XXXXXXXX XXXXXXXX XXXXXXX0			
0xB0400210	IRQ0_IRQVA97 XXXXXXXX XXXXXXXX XXXXXXXX XXXXXXX0				IRQ0_IRQVA96 XXXXXXXX XXXXXXXX XXXXXXXX XXXXXXX0			
0xB0400218	IRQ0_IRQVA99 XXXXXXXX XXXXXXXX XXXXXXXX XXXXXXX0				IRQ0_IRQVA98 XXXXXXXX XXXXXXXX XXXXXXXX XXXXXXX0			
0xB0400220	IRQ0_IRQVA101 XXXXXXXX XXXXXXXX XXXXXXXX XXXXXXX0				IRQ0_IRQVA100 XXXXXXXX XXXXXXXX XXXXXXXX XXXXXXX0			
0xB0400228	reserved XXXXXXXX XXXXXXXX XXXXXXXX XXXXXXXX				IRQ0_IRQVA102 XXXXXXXX XXXXXXXX XXXXXXXX XXXXXXX0			
0xB0400230	IRQ0_IRQVA105 XXXXXXXX XXXXXXXX XXXXXXXX XXXXXXX0				IRQ0_IRQVA104 XXXXXXXX XXXXXXXX XXXXXXXX XXXXXXX0			
0xB0400238	IRQ0_IRQVA107 XXXXXXXX XXXXXXXX XXXXXXXX XXXXXXX0				IRQ0_IRQVA106 XXXXXXXX XXXXXXXX XXXXXXXX XXXXXXX0			
0xB0400240	reserved XXXXXXXX XXXXXXXX XXXXXXXX XXXXXXXX				reserved XXXXXXXX XXXXXXXX XXXXXXXX XXXXXXXX			
0xB0400248	reserved XXXXXXXX XXXXXXXX XXXXXXXX XXXXXXXX				reserved XXXXXXXX XXXXXXXX XXXXXXXX XXXXXXXX			
0xB0400250	IRQ0_IRQVA113 XXXXXXXX XXXXXXXX XXXXXXXX XXXXXXX0				IRQ0_IRQVA112 XXXXXXXX XXXXXXXX XXXXXXXX XXXXXXX0			

Table 32. Memory Layout of MEMORY_CONFIG Registers with Default Values (Continued)

Offset	+7	+6	+5	+4	+3	+2	+1	+0
0xB0400258	IRQ0_IRQVA115 XXXXXXXX XXXXXXXX XXXXXXXX XXXXXX00				IRQ0_IRQVA114 XXXXXXXX XXXXXXXX XXXXXXXX XXXXXX00			
0xB0400260	reserved XXXXXXXX XXXXXXXX XXXXXXXX XXXXXXXX				reserved XXXXXXXX XXXXXXXX XXXXXXXX XXXXXXXX			
0xB0400268	reserved XXXXXXXX XXXXXXXX XXXXXXXX XXXXXXXX				reserved XXXXXXXX XXXXXXXX XXXXXXXX XXXXXXXX			
0xB0400270	reserved XXXXXXXX XXXXXXXX XXXXXXXX XXXXXXXX				reserved XXXXXXXX XXXXXXXX XXXXXXXX XXXXXXXX			
0xB0400278	reserved XXXXXXXX XXXXXXXX XXXXXXXX XXXXXXXX				reserved XXXXXXXX XXXXXXXX XXXXXXXX XXXXXXXX			
0xB0400280	IRQ0_IRQVA125 XXXXXXXX XXXXXXXX XXXXXXXX XXXXXX00				IRQ0_IRQVA124 XXXXXXXX XXXXXXXX XXXXXXXX XXXXXX00			
0xB0400288	IRQ0_IRQVA127 XXXXXXXX XXXXXXXX XXXXXXXX XXXXXX00				IRQ0_IRQVA126 XXXXXXXX XXXXXXXX XXXXXXXX XXXXXX00			
0xB0400290	reserved XXXXXXXX XXXXXXXX XXXXXXXX XXXXXXXX				reserved XXXXXXXX XXXXXXXX XXXXXXXX XXXXXXXX			
0xB0400298	reserved XXXXXXXX XXXXXXXX XXXXXXXX XXXXXXXX				reserved XXXXXXXX XXXXXXXX XXXXXXXX XXXXXXXX			
0xB04002A0	IRQ0_IRQVA133 XXXXXXXX XXXXXXXX XXXXXXXX XXXXXX00				IRQ0_IRQVA132 XXXXXXXX XXXXXXXX XXXXXXXX XXXXXX00			
0xB04002A8	IRQ0_IRQVA135 XXXXXXXX XXXXXXXX XXXXXXXX XXXXXX00				IRQ0_IRQVA134 XXXXXXXX XXXXXXXX XXXXXXXX XXXXXX00			
0xB04002B0	IRQ0_IRQVA137 XXXXXXXX XXXXXXXX XXXXXXXX XXXXXX00				IRQ0_IRQVA136 XXXXXXXX XXXXXXXX XXXXXXXX XXXXXX00			
0xB04002B8	IRQ0_IRQVA139 XXXXXXXX XXXXXXXX XXXXXXXX XXXXXX00				IRQ0_IRQVA138 XXXXXXXX XXXXXXXX XXXXXXXX XXXXXX00			
0xB04002C0	reserved XXXXXXXX XXXXXXXX XXXXXXXX XXXXXXXX				reserved XXXXXXXX XXXXXXXX XXXXXXXX XXXXXXXX			
0xB04002C8	reserved XXXXXXXX XXXXXXXX XXXXXXXX XXXXXXXX				reserved XXXXXXXX XXXXXXXX XXXXXXXX XXXXXXXX			
0xB04002D0	IRQ0_IRQVA145 XXXXXXXX XXXXXXXX XXXXXXXX XXXXXX00				IRQ0_IRQVA144 XXXXXXXX XXXXXXXX XXXXXXXX XXXXXX00			
0xB04002D8	IRQ0_IRQVA147 XXXXXXXX XXXXXXXX XXXXXXXX XXXXXX00				IRQ0_IRQVA146 XXXXXXXX XXXXXXXX XXXXXXXX XXXXXX00			
0xB04002E0	reserved XXXXXXXX XXXXXXXX XXXXXXXX XXXXXXXX				reserved XXXXXXXX XXXXXXXX XXXXXXXX XXXXXXXX			
0xB04002E8	reserved XXXXXXXX XXXXXXXX XXXXXXXX XXXXXXXX				reserved XXXXXXXX XXXXXXXX XXXXXXXX XXXXXXXX			
0xB04002F0	IRQ0_IRQVA153 XXXXXXXX XXXXXXXX XXXXXXXX XXXXXX00				IRQ0_IRQVA152 XXXXXXXX XXXXXXXX XXXXXXXX XXXXXX00			
0xB04002F8	reserved XXXXXXXX XXXXXXXX XXXXXXXX XXXXXXXX				IRQ0_IRQVA154 XXXXXXXX XXXXXXXX XXXXXXXX XXXXXX00			
0xB0400300	reserved XXXXXXXX XXXXXXXX XXXXXXXX XXXXXXXX				reserved XXXXXXXX XXXXXXXX XXXXXXXX XXXXXXXX			
0xB0400308	IRQ0_IRQVA159 XXXXXXXX XXXXXXXX XXXXXXXX XXXXXX00				IRQ0_IRQVA158 XXXXXXXX XXXXXXXX XXXXXXXX XXXXXX00			
0xB0400310	reserved XXXXXXXX XXXXXXXX XXXXXXXX XXXXXXXX				IRQ0_IRQVA160 XXXXXXXX XXXXXXXX XXXXXXXX XXXXXX00			
0xB0400318	reserved XXXXXXXX XXXXXXXX XXXXXXXX XXXXXXXX				reserved XXXXXXXX XXXXXXXX XXXXXXXX XXXXXXXX			

Table 32. Memory Layout of MEMORY_CONFIG Registers with Default Values (Continued)

Offset	+7	+6	+5	+4	+3	+2	+1	+0
0xB0400320	IRQ0_IRQVA165 XXXXXXXX XXXXXXXX XXXXXXXX XXXXXX00				IRQ0_IRQVA164 XXXXXXXX XXXXXXXX XXXXXXXX XXXXXX00			
0xB0400328	IRQ0_IRQVA167 XXXXXXXX XXXXXXXX XXXXXXXX XXXXXX00				IRQ0_IRQVA166 XXXXXXXX XXXXXXXX XXXXXXXX XXXXXX00			
0xB0400330	IRQ0_IRQVA169 XXXXXXXX XXXXXXXX XXXXXXXX XXXXXX00				IRQ0_IRQVA168 XXXXXXXX XXXXXXXX XXXXXXXX XXXXXX00			
0xB0400338	IRQ0_IRQVA171 XXXXXXXX XXXXXXXX XXXXXXXX XXXXXX00				IRQ0_IRQVA170 XXXXXXXX XXXXXXXX XXXXXXXX XXXXXX00			
0xB0400340	IRQ0_IRQVA173 XXXXXXXX XXXXXXXX XXXXXXXX XXXXXX00				IRQ0_IRQVA172 XXXXXXXX XXXXXXXX XXXXXXXX XXXXXX00			
0xB0400348	IRQ0_IRQVA175 XXXXXXXX XXXXXXXX XXXXXXXX XXXXXX00				IRQ0_IRQVA174 XXXXXXXX XXXXXXXX XXXXXXXX XXXXXX00			
0xB0400350	IRQ0_IRQVA177 XXXXXXXX XXXXXXXX XXXXXXXX XXXXXX00				IRQ0_IRQVA176 XXXXXXXX XXXXXXXX XXXXXXXX XXXXXX00			
0xB0400358	IRQ0_IRQVA179 XXXXXXXX XXXXXXXX XXXXXXXX XXXXXX00				IRQ0_IRQVA178 XXXXXXXX XXXXXXXX XXXXXXXX XXXXXX00			
0xB0400360	IRQ0_IRQVA181 XXXXXXXX XXXXXXXX XXXXXXXX XXXXXX00				IRQ0_IRQVA180 XXXXXXXX XXXXXXXX XXXXXXXX XXXXXX00			
0xB0400368	IRQ0_IRQVA183 XXXXXXXX XXXXXXXX XXXXXXXX XXXXXX00				IRQ0_IRQVA182 XXXXXXXX XXXXXXXX XXXXXXXX XXXXXX00			
0xB0400370	IRQ0_IRQVA185 XXXXXXXX XXXXXXXX XXXXXXXX XXXXXX00				IRQ0_IRQVA184 XXXXXXXX XXXXXXXX XXXXXXXX XXXXXX00			
0xB0400378	IRQ0_IRQVA187 XXXXXXXX XXXXXXXX XXXXXXXX XXXXXX00				IRQ0_IRQVA186 XXXXXXXX XXXXXXXX XXXXXXXX XXXXXX00			
0xB0400380	reserved XXXXXXXX XXXXXXXX XXXXXXXX XXXXXXXX				reserved XXXXXXXX XXXXXXXX XXXXXXXX XXXXXXXX			
0xB0400388	reserved XXXXXXXX XXXXXXXX XXXXXXXX XXXXXXXX				reserved XXXXXXXX XXXXXXXX XXXXXXXX XXXXXXXX			
0xB0400390	reserved XXXXXXXX XXXXXXXX XXXXXXXX XXXXXXXX				reserved XXXXXXXX XXXXXXXX XXXXXXXX XXXXXXXX			
0xB0400398	IRQ0_IRQVA195 XXXXXXXX XXXXXXXX XXXXXXXX XXXXXX00				IRQ0_IRQVA194 XXXXXXXX XXXXXXXX XXXXXXXX XXXXXX00			
0xB04003A0	reserved XXXXXXXX XXXXXXXX XXXXXXXX XXXXXXXX				reserved XXXXXXXX XXXXXXXX XXXXXXXX XXXXXXXX			
0xB04003A8	IRQ0_IRQVA199 XXXXXXXX XXXXXXXX XXXXXXXX XXXXXX00				IRQ0_IRQVA198 XXXXXXXX XXXXXXXX XXXXXXXX XXXXXX00			
0xB04003B0	reserved XXXXXXXX XXXXXXXX XXXXXXXX XXXXXXXX				reserved XXXXXXXX XXXXXXXX XXXXXXXX XXXXXXXX			
0xB04003B8	IRQ0_IRQVA203 XXXXXXXX XXXXXXXX XXXXXXXX XXXXXX00				IRQ0_IRQVA202 XXXXXXXX XXXXXXXX XXXXXXXX XXXXXX00			
0xB04003C0	reserved XXXXXXXX XXXXXXXX XXXXXXXX XXXXXXXX				reserved XXXXXXXX XXXXXXXX XXXXXXXX XXXXXXXX			
0xB04003C8	reserved XXXXXXXX XXXXXXXX XXXXXXXX XXXXXXXX				IRQ0_IRQVA206 XXXXXXXX XXXXXXXX XXXXXXXX XXXXXX00			
0xB04003D0	IRQ0_IRQVA209 XXXXXXXX XXXXXXXX XXXXXXXX XXXXXX00				IRQ0_IRQVA208 XXXXXXXX XXXXXXXX XXXXXXXX XXXXXX00			
0xB04003D8	IRQ0_IRQVA211 XXXXXXXX XXXXXXXX XXXXXXXX XXXXXX00				IRQ0_IRQVA210 XXXXXXXX XXXXXXXX XXXXXXXX XXXXXX00			
0xB04003E0	IRQ0_IRQVA213 XXXXXXXX XXXXXXXX XXXXXXXX XXXXXX00				IRQ0_IRQVA212 XXXXXXXX XXXXXXXX XXXXXXXX XXXXXX00			

Table 32. Memory Layout of MEMORY_CONFIG Registers with Default Values (Continued)

Offset	+7	+6	+5	+4	+3	+2	+1	+0
0xB04003E8	IRQ0_IRQVA215 XXXXXXXX XXXXXXXX XXXXXXXX XXXXXXX0				IRQ0_IRQVA214 XXXXXXXX XXXXXXXX XXXXXXXX XXXXXXX0			
0xB04003F0	IRQ0_IRQVA217 XXXXXXXX XXXXXXXX XXXXXXXX XXXXXXX0				IRQ0_IRQVA216 XXXXXXXX XXXXXXXX XXXXXXXX XXXXXXX0			
0xB04003F8	IRQ0_IRQVA219 XXXXXXXX XXXXXXXX XXXXXXXX XXXXXXX0				IRQ0_IRQVA218 XXXXXXXX XXXXXXXX XXXXXXXX XXXXXXX0			
0xB0400400	IRQ0_IRQVA221 XXXXXXXX XXXXXXXX XXXXXXXX XXXXXXX0				IRQ0_IRQVA220 XXXXXXXX XXXXXXXX XXXXXXXX XXXXXXX0			
0xB0400408	IRQ0_IRQVA223 XXXXXXXX XXXXXXXX XXXXXXXX XXXXXXX0				IRQ0_IRQVA222 XXXXXXXX XXXXXXXX XXXXXXXX XXXXXXX0			
0xB0400410	reserved XXXXXXXX XXXXXXXX XXXXXXXX XXXXXXXX				reserved XXXXXXXX XXXXXXXX XXXXXXXX XXXXXXXX			
0xB0400418	reserved XXXXXXXX XXXXXXXX XXXXXXXX XXXXXXXX				reserved XXXXXXXX XXXXXXXX XXXXXXXX XXXXXXXX			
0xB0400420	reserved XXXXXXXX XXXXXXXX XXXXXXXX XXXXXXXX				reserved XXXXXXXX XXXXXXXX XXXXXXXX XXXXXXXX			
0xB0400428	reserved XXXXXXXX XXXXXXXX XXXXXXXX XXXXXXXX				reserved XXXXXXXX XXXXXXXX XXXXXXXX XXXXXXXX			
0xB0400430	IRQ0_IRQVA233 XXXXXXXX XXXXXXXX XXXXXXXX XXXXXXX0				IRQ0_IRQVA232 XXXXXXXX XXXXXXXX XXXXXXXX XXXXXXX0			
0xB0400438	IRQ0_IRQVA235 XXXXXXXX XXXXXXXX XXXXXXXX XXXXXXX0				IRQ0_IRQVA234 XXXXXXXX XXXXXXXX XXXXXXXX XXXXXXX0			
0xB0400440	IRQ0_IRQVA237 XXXXXXXX XXXXXXXX XXXXXXXX XXXXXXX0				IRQ0_IRQVA236 XXXXXXXX XXXXXXXX XXXXXXXX XXXXXXX0			
0xB0400448	IRQ0_IRQVA239 XXXXXXXX XXXXXXXX XXXXXXXX XXXXXXX0				IRQ0_IRQVA238 XXXXXXXX XXXXXXXX XXXXXXXX XXXXXXX0			
0xB0400450 - 0xB0400888	reserved XXXXXXXX XXXXXXXX XXXXXXXX XXXXXXXX				reserved XXXXXXXX XXXXXXXX XXXXXXXX XXXXXXXX			
0xB0400890	IRQ0_NMIPL1 00001111 00000000 00001111 00001111				IRQ0_NMIPL0 00001111 00001111 00001111 00000000			
0xB0400898	IRQ0_NMIPL3 00000000 00001111 00001111 00001111				IRQ0_NMIPL2 00001111 00000000 00001111 00001111			
0xB04008A0	reserved XXXXXXXX XXXXXXXX XXXXXXXX XXXXXXXX				IRQ0_NMIPL4 00000000 00001111 00000000 00000000			
0xB04008A8	reserved XXXXXXXX XXXXXXXX XXXXXXXX XXXXXXXX				reserved XXXXXXXX XXXXXXXX XXXXXXXX XXXXXXXX			
0xB04008B0	reserved XXXXXXXX XXXXXXXX XXXXXXXX XXXXXXXX				IRQ0_IRQPL0 00000000 00000000 00011111 00011111			
0xB04008B8	IRQ0_IRQPL3 00011111 00000000 00000000 00000000				reserved XXXXXXXX XXXXXXXX XXXXXXXX XXXXXXXX			
0xB04008C0	IRQ0_IRQPL5 00011111 00011111 00000000 00000000				IRQ0_IRQPL4 00000000 00000000 00000000 00011111			
0xB04008C8	IRQ0_IRQPL7 00011111 00011111 00000000 00000000				reserved XXXXXXXX XXXXXXXX XXXXXXXX XXXXXXXX			
0xB04008D0	IRQ0_IRQPL9 00000000 00011111 00011111 00011111				IRQ0_IRQPL8 00011111 00011111 00011111 00011111			
0xB04008D8	IRQ0_IRQPL11 00000000 00000000 00011111 00011111				IRQ0_IRQPL10 00011111 00011111 00011111 00011111			
0xB04008E0	IRQ0_IRQPL13 00011111 00000000 00011111 00011111				IRQ0_IRQPL12 00000000 00011111 00011111 00011111			

Table 32. Memory Layout of MEMORY_CONFIG Registers with Default Values (Continued)

Offset	+7	+6	+5	+4	+3	+2	+1	+0
0xB04008E8	IRQ0_IRQPL15 00000000 00011111 00011111 00000000				IRQ0_IRQPL14 00000000 00000000 00000000 00011111			
0xB04008F0	IRQ0_IRQPL17 00011111 00011111 00011111 00000000				reserved XXXXXXXX XXXXXXXX XXXXXXXX XXXXXXXX			
0xB04008F8	IRQ0_IRQPL19 00011111 00011111 00011111 00011111				IRQ0_IRQPL18 00011111 00011111 00011111 00011111			
0xB0400900	IRQ0_IRQPL21 00011111 00011111 00011111 00011111				IRQ0_IRQPL20 00011111 00011111 00011111 00011111			
0xB0400908	IRQ0_IRQPL23 00011111 00011111 00011111 00011111				IRQ0_IRQPL22 00011111 00011111 00011111 00011111			
0xB0400910	IRQ0_IRQPL25 00000000 00011111 00011111 00011111				IRQ0_IRQPL24 00011111 00011111 00011111 00011111			
0xB0400918	reserved XXXXXXXX XXXXXXXX XXXXXXXX XXXXXXXX				IRQ0_IRQPL26 00011111 00011111 00011111 00011111			
0xB0400920	reserved XXXXXXXX XXXXXXXX XXXXXXXX XXXXXXXX				IRQ0_IRQPL28 00011111 00011111 00011111 00011111			
0xB0400928	IRQ0_IRQPL31 00011111 00011111 00011111 00011111				reserved XXXXXXXX XXXXXXXX XXXXXXXX XXXXXXXX			
0xB0400930	IRQ0_IRQPL33 00011111 00011111 00011111 00011111				reserved XXXXXXXX XXXXXXXX XXXXXXXX XXXXXXXX			
0xB0400938	reserved XXXXXXXX XXXXXXXX XXXXXXXX XXXXXXXX				IRQ0_IRQPL34 00011111 00011111 00011111 00011111			
0xB0400940	reserved XXXXXXXX XXXXXXXX XXXXXXXX XXXXXXXX				IRQ0_IRQPL36 00011111 00011111 00011111 00011111			
0xB0400948	IRQ0_IRQPL39 00011111 00011111 00000000 00000000				IRQ0_IRQPL38 00000000 00011111 00011111 00011111			
0xB0400950	IRQ0_IRQPL41 00011111 00011111 00011111 00011111				IRQ0_IRQPL40 00000000 00000000 00000000 00011111			
0xB0400958	IRQ0_IRQPL43 00011111 00011111 00011111 00011111				IRQ0_IRQPL42 00011111 00011111 00011111 00011111			
0xB0400960	IRQ0_IRQPL45 00011111 00011111 00011111 00011111				IRQ0_IRQPL44 00011111 00011111 00011111 00011111			
0xB0400968	reserved XXXXXXXX XXXXXXXX XXXXXXXX XXXXXXXX				IRQ0_IRQPL46 00011111 00011111 00011111 00011111			
0xB0400970	IRQ0_IRQPL49 00011111 00011111 00000000 00000000				IRQ0_IRQPL48 00011111 00011111 00000000 00000000			
0xB0400978	IRQ0_IRQPL51 00000000 00011111 00000000 00000000				IRQ0_IRQPL50 00011111 00011111 00000000 00000000			
0xB0400980	IRQ0_IRQPL53 00011111 00011111 00011111 00011111				IRQ0_IRQPL52 00011111 00011111 00011111 00011111			
0xB0400988	IRQ0_IRQPL55 00011111 00011111 00011111 00011111				IRQ0_IRQPL54 00011111 00011111 00011111 00011111			
0xB0400990	reserved XXXXXXXX XXXXXXXX XXXXXXXX XXXXXXXX				reserved XXXXXXXX XXXXXXXX XXXXXXXX XXXXXXXX			
0xB0400998	IRQ0_IRQPL59 00011111 00011111 00011111 00011111				IRQ0_IRQPL58 00011111 00011111 00011111 00011111			
0xB04009A0 - 0xB0400AA8	reserved XXXXXXXX XXXXXXXX XXXXXXXX XXXXXXXX				reserved XXXXXXXX XXXXXXXX XXXXXXXX XXXXXXXX			
0xB0400AB0	IRQ0_NMIR 00000000 00000000 00000000 00000000				IRQ0_NMIS 00000000 00000000 00000000 00000000			

Table 32. Memory Layout of MEMORY_CONFIG Registers with Default Values (Continued)

Offset	+7	+6	+5	+4	+3	+2	+1	+0
0xB0400AB8	read0 00000000 00000000 00000000 00000000				IRQ0_NMISIS 00000000 00000000 00000000 00000000			
0xB0400AC0	IRQ0_IRQS1 00000000 00000000 00000000 00000000				IRQ0_IRQS0 00000000 00000000 00000000 00000000			
0xB0400AC8	IRQ0_IRQS3 00000000 00000000 00000000 00000000				IRQ0_IRQS2 00000000 00000000 00000000 00000000			
0xB0400AD0	IRQ0_IRQS5 00000000 00000000 00000000 00000000				IRQ0_IRQS4 00000000 00000000 00000000 00000000			
0xB0400AD8	IRQ0_IRQS7 00000000 00000000 00000000 00000000				IRQ0_IRQS6 00000000 00000000 00000000 00000000			
0xB0400AE0	reserved XXXXXXXX XXXXXXXX XXXXXXXX XXXXXXXX				reserved XXXXXXXX XXXXXXXX XXXXXXXX XXXXXXXX			
0xB0400AE8	reserved XXXXXXXX XXXXXXXX XXXXXXXX XXXXXXXX				reserved XXXXXXXX XXXXXXXX XXXXXXXX XXXXXXXX			
0xB0400AF0	reserved XXXXXXXX XXXXXXXX XXXXXXXX XXXXXXXX				reserved XXXXXXXX XXXXXXXX XXXXXXXX XXXXXXXX			
0xB0400AF8	reserved XXXXXXXX XXXXXXXX XXXXXXXX XXXXXXXX				reserved XXXXXXXX XXXXXXXX XXXXXXXX XXXXXXXX			
0xB0400B00	IRQ0_IRQR1 00000000 00000000 00000000 00000000				IRQ0_IRQR0 00000000 00000000 00000000 00000000			
0xB0400B08	IRQ0_IRQR3 00000000 00000000 00000000 00000000				IRQ0_IRQR2 00000000 00000000 00000000 00000000			
0xB0400B10	IRQ0_IRQR5 00000000 00000000 00000000 00000000				IRQ0_IRQR4 00000000 00000000 00000000 00000000			
0xB0400B18	IRQ0_IRQR7 00000000 00000000 00000000 00000000				IRQ0_IRQR6 00000000 00000000 00000000 00000000			
0xB0400B20	reserved XXXXXXXX XXXXXXXX XXXXXXXX XXXXXXXX				reserved XXXXXXXX XXXXXXXX XXXXXXXX XXXXXXXX			
0xB0400B28	reserved XXXXXXXX XXXXXXXX XXXXXXXX XXXXXXXX				reserved XXXXXXXX XXXXXXXX XXXXXXXX XXXXXXXX			
0xB0400B30	reserved XXXXXXXX XXXXXXXX XXXXXXXX XXXXXXXX				reserved XXXXXXXX XXXXXXXX XXXXXXXX XXXXXXXX			
0xB0400B38	reserved XXXXXXXX XXXXXXXX XXXXXXXX XXXXXXXX				reserved XXXXXXXX XXXXXXXX XXXXXXXX XXXXXXXX			
0xB0400B40	IRQ0_IRQSIS1 00000000 00000000 00000000 00000000				IRQ0_IRQSIS0 00000000 00000000 00000000 00000000			
0xB0400B48	IRQ0_IRQSIS3 00000000 00000000 00000000 00000000				IRQ0_IRQSIS2 00000000 00000000 00000000 00000000			
0xB0400B50	IRQ0_IRQSIS5 00000000 00000000 00000000 00000000				IRQ0_IRQSIS4 00000000 00000000 00000000 00000000			
0xB0400B58	IRQ0_IRQSIS7 00000000 00000000 00000000 00000000				IRQ0_IRQSIS6 00000000 00000000 00000000 00000000			
0xB0400B60	reserved XXXXXXXX XXXXXXXX XXXXXXXX XXXXXXXX				reserved XXXXXXXX XXXXXXXX XXXXXXXX XXXXXXXX			
0xB0400B68	reserved XXXXXXXX XXXXXXXX XXXXXXXX XXXXXXXX				reserved XXXXXXXX XXXXXXXX XXXXXXXX XXXXXXXX			
0xB0400B70	reserved XXXXXXXX XXXXXXXX XXXXXXXX XXXXXXXX				reserved XXXXXXXX XXXXXXXX XXXXXXXX XXXXXXXX			
0xB0400B78	reserved XXXXXXXX XXXXXXXX XXXXXXXX XXXXXXXX				reserved XXXXXXXX XXXXXXXX XXXXXXXX XXXXXXXX			

Table 32. Memory Layout of MEMORY_CONFIG Registers with Default Values (Continued)

Offset	+7	+6	+5	+4	+3	+2	+1	+0
0xB0400B80	IRQ0_IRQCES1 00000000 00000000 00000000 00000000				IRQ0_IRQCES0 00000000 00000000 00000000 00000000			
0xB0400B88	IRQ0_IRQCES3 00000000 00000000 00000000 00000000				IRQ0_IRQCES2 00000000 00000000 00000000 00000000			
0xB0400B90	IRQ0_IRQCES5 00000000 00000000 00000000 00000000				IRQ0_IRQCES4 00000000 00000000 00000000 00000000			
0xB0400B98	IRQ0_IRQCES7 00000000 00000000 00000000 00000000				IRQ0_IRQCES6 00000000 00000000 00000000 00000000			
0xB0400BA0	reserved XXXXXXXX XXXXXXXX XXXXXXXX XXXXXXXX				reserved XXXXXXXX XXXXXXXX XXXXXXXX XXXXXXXX			
0xB0400BA8	reserved XXXXXXXX XXXXXXXX XXXXXXXX XXXXXXXX				reserved XXXXXXXX XXXXXXXX XXXXXXXX XXXXXXXX			
0xB0400BB0	reserved XXXXXXXX XXXXXXXX XXXXXXXX XXXXXXXX				reserved XXXXXXXX XXXXXXXX XXXXXXXX XXXXXXXX			
0xB0400BB8	reserved XXXXXXXX XXXXXXXX XXXXXXXX XXXXXXXX				reserved XXXXXXXX XXXXXXXX XXXXXXXX XXXXXXXX			
0xB0400BC0	IRQ0_IRQCEC1 00000000 00000000 00000000 00000000				IRQ0_IRQCEC0 00000000 00000000 00000000 00000000			
0xB0400BC8	IRQ0_IRQCEC3 00000000 00000000 00000000 00000000				IRQ0_IRQCEC2 00000000 00000000 00000000 00000000			
0xB0400BD0	IRQ0_IRQCEC5 00000000 00000000 00000000 00000000				IRQ0_IRQCEC4 00000000 00000000 00000000 00000000			
0xB0400BD8	IRQ0_IRQCEC7 00000000 00000000 00000000 00000000				IRQ0_IRQCEC6 00000000 00000000 00000000 00000000			
0xB0400BE0	reserved XXXXXXXX XXXXXXXX XXXXXXXX XXXXXXXX				reserved XXXXXXXX XXXXXXXX XXXXXXXX XXXXXXXX			
0xB0400BE8	reserved XXXXXXXX XXXXXXXX XXXXXXXX XXXXXXXX				reserved XXXXXXXX XXXXXXXX XXXXXXXX XXXXXXXX			
0xB0400BF0	reserved XXXXXXXX XXXXXXXX XXXXXXXX XXXXXXXX				reserved XXXXXXXX XXXXXXXX XXXXXXXX XXXXXXXX			
0xB0400BF8	reserved XXXXXXXX XXXXXXXX XXXXXXXX XXXXXXXX				reserved XXXXXXXX XXXXXXXX XXXXXXXX XXXXXXXX			
0xB0400C00	IRQ0_IRQCE1 00000000 00000000 00000000 00000000				IRQ0_IRQCE0 00000000 00000000 00000000 00000000			
0xB0400C08	IRQ0_IRQCE3 00000000 00000000 00000000 00000000				IRQ0_IRQCE2 00000000 00000000 00000000 00000000			
0xB0400C10	IRQ0_IRQCE5 00000000 00000000 00000000 00000000				IRQ0_IRQCE4 00000000 00000000 00000000 00000000			
0xB0400C18	IRQ0_IRQCE7 00000000 00000000 00000000 00000000				IRQ0_IRQCE6 00000000 00000000 00000000 00000000			
0xB0400C20	reserved XXXXXXXX XXXXXXXX XXXXXXXX XXXXXXXX				reserved XXXXXXXX XXXXXXXX XXXXXXXX XXXXXXXX			
0xB0400C28	reserved XXXXXXXX XXXXXXXX XXXXXXXX XXXXXXXX				reserved XXXXXXXX XXXXXXXX XXXXXXXX XXXXXXXX			
0xB0400C30	reserved XXXXXXXX XXXXXXXX XXXXXXXX XXXXXXXX				reserved XXXXXXXX XXXXXXXX XXXXXXXX XXXXXXXX			
0xB0400C38	reserved XXXXXXXX XXXXXXXX XXXXXXXX XXXXXXXX				reserved XXXXXXXX XXXXXXXX XXXXXXXX XXXXXXXX			
0xB0400C40	IRQ0_NMIHS 00000000 00000000 00000000 00000000				IRQ0_NMIHC 00000000 00000000 00000000 00000000			

Table 32. Memory Layout of MEMORY_CONFIG Registers with Default Values (Continued)

Offset	+7	+6	+5	+4	+3	+2	+1	+0
0xB0400C48	read0 00000000 00000000 00000000 00000000				IRQ0_IRQHC 00000000 00000000 00000000 00000000			
0xB0400C50	IRQ0_IRQHS1 00000000 00000000 00000000 00000000				IRQ0_IRQHS0 00000000 00000000 00000000 00000000			
0xB0400C58	IRQ0_IRQHS3 00000000 00000000 00000000 00000000				IRQ0_IRQHS2 00000000 00000000 00000000 00000000			
0xB0400C60	IRQ0_IRQHS5 00000000 00000000 00000000 00000000				IRQ0_IRQHS4 00000000 00000000 00000000 00000000			
0xB0400C68	IRQ0_IRQHS7 00000000 00000000 00000000 00000000				IRQ0_IRQHS6 00000000 00000000 00000000 00000000			
0xB0400C70	reserved XXXXXXXX XXXXXXXX XXXXXXXX XXXXXXXX				reserved XXXXXXXX XXXXXXXX XXXXXXXX XXXXXXXX			
0xB0400C78	reserved XXXXXXXX XXXXXXXX XXXXXXXX XXXXXXXX				reserved XXXXXXXX XXXXXXXX XXXXXXXX XXXXXXXX			
0xB0400C80	reserved XXXXXXXX XXXXXXXX XXXXXXXX XXXXXXXX				reserved XXXXXXXX XXXXXXXX XXXXXXXX XXXXXXXX			
0xB0400C88	reserved XXXXXXXX XXXXXXXX XXXXXXXX XXXXXXXX				reserved XXXXXXXX XXXXXXXX XXXXXXXX XXXXXXXX			
0xB0400C90	read0 00000000 00000000 00000000 00000000				IRQ0_IRQPLM 00000000 00000000 00000000 00100000			
0xB0400C98	read0 00000000 00000000 00000000 00000000				IRQ0_CSR 00000000 00000001 00000000 00000000			
0xB0400CA0	read0 00000000 00000000 00000000 00000000				IRQ0_NESTL 00000000 00000000 00000000 00000000			
0xB0400CA8	IRQ0_NMIPS 00000000 00000000 00000000 00000000				IRQ0_NMIRS 00000000 00000000 00000000 00000000			
0xB0400CB0	IRQ0_IRQRS1 00000000 00000000 00000000 00000000				IRQ0_IRQRS0 00000000 00000000 00000000 00000000			
0xB0400CB8	IRQ0_IRQRS3 00000000 00000000 00000000 00000000				IRQ0_IRQRS2 00000000 00000000 00000000 00000000			
0xB0400CC0	IRQ0_IRQRS5 00000000 00000000 00000000 00000000				IRQ0_IRQRS4 00000000 00000000 00000000 00000000			
0xB0400CC8	IRQ0_IRQRS7 00000000 00000000 00000000 00000000				IRQ0_IRQRS6 00000000 00000000 00000000 00000000			
0xB0400CD0	reserved XXXXXXXX XXXXXXXX XXXXXXXX XXXXXXXX				read0 00000000 00000000 00000000 00000000			
0xB0400CD8	reserved XXXXXXXX XXXXXXXX XXXXXXXX XXXXXXXX				reserved XXXXXXXX XXXXXXXX XXXXXXXX XXXXXXXX			
0xB0400CE0	reserved XXXXXXXX XXXXXXXX XXXXXXXX XXXXXXXX				reserved XXXXXXXX XXXXXXXX XXXXXXXX XXXXXXXX			
0xB0400CE8	reserved XXXXXXXX XXXXXXXX XXXXXXXX XXXXXXXX				reserved XXXXXXXX XXXXXXXX XXXXXXXX XXXXXXXX			
0xB0400CF0	IRQ0_IRQPS1 00000000 00000000 00000000 00000000				IRQ0_IRQPS0 00000000 00000000 00000000 00000000			
0xB0400CF8	IRQ0_IRQPS3 00000000 00000000 00000000 00000000				IRQ0_IRQPS2 00000000 00000000 00000000 00000000			
0xB0400D00	IRQ0_IRQPS5 00000000 00000000 00000000 00000000				IRQ0_IRQPS4 00000000 00000000 00000000 00000000			
0xB0400D08	IRQ0_IRQPS7 00000000 00000000 00000000 00000000				IRQ0_IRQPS6 00000000 00000000 00000000 00000000			

Table 32. Memory Layout of MEMORY_CONFIG Registers with Default Values (Continued)

Offset	+7	+6	+5	+4	+3	+2	+1	+0
0xB0400D10	reserved XXXXXXXX XXXXXXXX XXXXXXXX XXXXXXXX				read0 00000000 00000000 00000000 00000000			
0xB0400D18	reserved XXXXXXXX XXXXXXXX XXXXXXXX XXXXXXXX				reserved XXXXXXXX XXXXXXXX XXXXXXXX XXXXXXXX			
0xB0400D20	reserved XXXXXXXX XXXXXXXX XXXXXXXX XXXXXXXX				reserved XXXXXXXX XXXXXXXX XXXXXXXX XXXXXXXX			
0xB0400D28	reserved XXXXXXXX XXXXXXXX XXXXXXXX XXXXXXXX				reserved XXXXXXXX XXXXXXXX XXXXXXXX XXXXXXXX			
0xB0400D30	read0 00000000 00000000 00000000 00000000				IRQ0_UNLOCK 00000000 00000000 00000000 00000000			
0xB0400D38	read0 00000000 00000000 00000000 00000000				IRQ0_MID 00000000 00000000 00000000 00000000			
0xB0400D40	IRQ0_EAN 00000000 00000000 00000000 00000000				IRQ0_EEI 00000000 00000000 00000000 00000000			
0xB0400D48	IRQ0_EEB0 00000000 00000000 00000000 00000000				IRQ0_ET 00000000 00000000 00000000 00000000			
0xB0400D50	IRQ0_EEB2 00000000 00000000 00000000 00000000				IRQ0_EEB1 00000000 00000000 00000000 00000000			
0xB0400D58- B0407FF8	reserved XXXXXXXX XXXXXXXX XXXXXXXX XXXXXXXX XXXXXXXX XXXXXXXX XXXXXXXX XXXXXXXX							
0xB0408000	TPU0_LST 00000000 00000000 00000000 00000001				TPU0_UNLOCK 00000000 00000000 00000000 00000000			
0xB0408008	TPU0_TIR 00000000 00000000 00000000 00000000				TPU0_CFG 00000000 00000000 00000000 00000000			
0xB0408010	TPU0_TIE 00000000 00000000 00000000 00000000				TPU0_TST 00000000 00000000 00000000 00000000			
0xB0408018	read0 00000000 00000000 00000000 00000000				TPU0_MID 00000000 00000000 00000000 00000000			
0xB0408020- B0408028	reserved XXXXXXXX XXXXXXXX XXXXXXXX XXXXXXXX XXXXXXXX XXXXXXXX XXXXXXXX XXXXXXXX							
0xB0408030	TPU0_TCN01 00000000 00000000 00000000 00000000				TPU0_TCN00 00000000 00000000 00000000 00000000			
0xB0408038	TPU0_TCN03 00000000 00000000 00000000 00000000				TPU0_TCN02 00000000 00000000 00000000 00000000			
0xB0408040	TPU0_TCN05 00000000 00000000 00000000 00000000				TPU0_TCN04 00000000 00000000 00000000 00000000			
0xB0408048	TPU0_TCN07 00000000 00000000 00000000 00000000				TPU0_TCN06 00000000 00000000 00000000 00000000			
0xB0408050	TPU0_TCN11 00000000 00000000 00000000 00000000				TPU0_TCN10 00000000 00000000 00000000 00000000			
0xB0408058	TPU0_TCN13 00000000 00000000 00000000 00000000				TPU0_TCN12 00000000 00000000 00000000 00000000			
0xB0408060	TPU0_TCN15 00000000 00000000 00000000 00000000				TPU0_TCN14 00000000 00000000 00000000 00000000			
0xB0408068	TPU0_TCN17 00000000 00000000 00000000 00000000				TPU0_TCN16 00000000 00000000 00000000 00000000			
0xB0408070	TPU0_TCC1 00000000 00000000 00000000 00000000				TPU0_TCC0 00000000 00000000 00000000 00000000			
0xB0408078	TPU0_TCC3 00000000 00000000 00000000 00000000				TPU0_TCC2 00000000 00000000 00000000 00000000			

Table 32. Memory Layout of MEMORY_CONFIG Registers with Default Values (Continued)

Offset	+7	+6	+5	+4	+3	+2	+1	+0
0xB0408080	TPU0_TCC5 00000000 00000000 00000000 00000000				TPU0_TCC4 00000000 00000000 00000000 00000000			
0xB0408088	TPU0_TCC7 00000000 00000000 00000000 00000000				TPU0_TCC6 00000000 00000000 00000000 00000000			
0xB0408090- B040FFF8	reserved XXXXXXXX XXXXXXXX XXXXXXXX XXXXXXXX XXXXXXXX XXXXXXXX XXXXXXXX XXXXXXXX							
0xB0410000	TRCFG_TCMCFG1 00000000 00000000 00000000 00000000				TRCFG_TCMCFG0 00000011 00000000 00000001 00000000			
0xB0410008	read0 00000000 00000000 00000000 00000000				TRCFG_TCMUNLOCK 00000000 00000000 00000000 00000000			
0xB0410010- B0410FF8	reserved XXXXXXXX XXXXXXXX XXXXXXXX XXXXXXXX XXXXXXXX XXXXXXXX XXXXXXXX XXXXXXXX							
0xB0411000	reserved 00000000 00000000 00000000 00000000				TCFCFG_FCPROTKEY 00000000 00000000 00000000 00000000			
0xB0411008	reserved 00000000 00000000 00000000 00000000				TCFCFG_FCFSR 00000000 00000000 00000000 00000001			
0xB0411010	reserved 00000000 00000000 00000000 00000000				TCFCFG_FECCTRL 00000000 00000000 00000000 00000000			
0xB0411018	TCFCFG_FECCEIR 00000000 00000000 00000000 00000000				TCFCFG_FDATEIR 00000000 00000000 00000000 00000000			
0xB0411020	TCFCFG_FICTRL1 00000000 00000000 00000000 00000000				TCFCFG_FICTRL0 00000000 00000000 00000000 00000000			
0xB0411028	TCFCFG_FICTRL3 00000000 00000000 00000000 00000000				TCFCFG_FICTRL2 00000000 00000000 00000000 00000000			
0xB0411030	reserved 00000000 00000000 00000000 00000000 00000000 00000000 00000000 00000000							
0xB0411038	TCFCFG_FSTAT1 00000000 00000000 00000000 00000000				TCFCFG_FSTAT0 00000000 00000000 00000000 00000000			
0xB0411040	TCFCFG_FSTAT3 00000000 00000000 00000000 00000000				TCFCFG_FSTAT2 00000000 00000000 00000000 00000000			
0xB0411048	reserved 00000000 00000000 00000000 00000000 00000000 00000000 00000000 00000000							
0xB0411050	TCFCFG_FECCEAR 00000000 00000000 00000000 00000000				TCFCFG_FSECEIR 00000000 00000000 00000000 00000000			
0xB0411058	reserved 00000000 00000000 00000000 00000000				TCFCFG_FMIDR 00000000 00000000 00000000 00000000			
0xB0411060	TCFCFG_FCAMHR0 00000000 00000000 000XXXXX XXXXXXXX				TCFCFG_FCAMLR0 XXXXXXXX XXXXXXXX XXXXXXXX XXXXXXXX			
0xB0411068	TCFCFG_FCAMHR1 00000000 00000000 000XXXXX XXXXXXXX				TCFCFG_FCAMLR1 XXXXXXXX XXXXXXXX XXXXXXXX XXXXXXXX			
0xB0411070	TCFCFG_FCAMHR2 00000000 00000000 000XXXXX XXXXXXXX				TCFCFG_FCAMLR2 XXXXXXXX XXXXXXXX XXXXXXXX XXXXXXXX			
0xB0411078	TCFCFG_FCAMHR3 00000000 00000000 000XXXXX XXXXXXXX				TCFCFG_FCAMLR3 XXXXXXXX XXXXXXXX XXXXXXXX XXXXXXXX			
0xB0411080- B0411FF8	reserved XXXXXXXX XXXXXXXX XXXXXXXX XXXXXXXX XXXXXXXX XXXXXXXX XXXXXXXX XXXXXXXX							
0xB0412000	reserved 00000000 00000000 00000000 00000000				EEFCFG_CPR 00000000 00000000 00000000 00000000			
0xB0412008	EEFCFG_ECR 00000000 00000000 00000000 00000000				EEFCFG_CR 00000000 00000000 00000000 00000010			

Table 32. Memory Layout of MEMORY_CONFIG Registers with Default Values (Continued)

Offset	+7	+6	+5	+4	+3	+2	+1	+0
0xB0412010	EEFCFG_WSR 00000000 00000000 00000000 00000000				EEFCFG_WCR 00000000 00000000 00000000 00000000			
0xB0412018	EEFCFG_EEIR 00000000 00000000 00000000 00000000				EEFCFG_DBEIR 00000000 00000000 00000000 00000000			
0xB0412020	EEFCFG_ICR 00000000 00000000 00000000 00000000				reserved 00000000 00000000 00000000 00000000			
0xB0412028	EEFCFG_SECIR 00000000 00000000 00000000 00000000				EEFCFG_SR 00000000 00000000 00000000 00000000			
0xB0412030	EEFCFG_MIR 00000000 00000000 00000000 00000000				EEFCFG_EEAR 00000000 00000000 00000000 00000000			
0xB0412038	reserved XXXXXXXX XXXXXXXX XXXXXXXX XXXXXXXX				EEFCFG_EMENR 00000000 00000000 00000000 00000000			
0xB0412040	reserved XXXXXXXX XXXXXXXX XXXXXXXX XXXXXXXX				reserved XXXXXXXX XXXXXXXX XXXXXXXX XXXXXXXX			
0xB0412048	EEFCFG_FCAMHR 00000000 00000000 00XXXXXX XXXXXXXX				EEFCFG_FCAMLR XXXXXXXX XXXXXXXX XXXXXXXX XXXXXXXX			
0xB0412050	EEFCFG_SEQCM 00000000 00000000 00000000 00000000				EEFCFG_SEQWM 00000000 00000000 00000000 00000000			
0xB0412058	EEFCFG_ARBCLR 00000000 00000000 00000000 00000000				EEFCFG_ARBERR 00000000 00000000 00000000 00000000			
0xB0412060	EEFCFG_BERRCLR 00000000 00000000 00000000 00000000				EEFCFG_BERR 00000000 00000000 00000000 00000000			
0xB0412068	read0 00000000 00000000 00000000 00000000				EEFCFG_BLANK 00000000 00000000 00000000 00000000			
0xB0412070- B0412FF8	reserved XXXXXXXX XXXXXXXX XXXXXXXX XXXXXXXX XXXXXXXX XXXXXXXX XXXXXXXX XXXXXXXX							
0xB0413000	SHE_CMDCANCEL 00000000 00000000 00000000 00000000				SHE_CMD 00000000 00000000 00000000 00000000			
0xB0413008	SHE_STATUS XXXX0000 00000000 00000000 00000000				SHE_CLKCTRL 00000000 00000000 00000000 00000000			
0xB0413010	SHE_CLKSTAT 00000000 00000000 00000000 00000000				SHE_ERC 00000000 00010000 00000000 00000000			
0xB0413018	SHE_IRQ 00000000 00000000 00000000 00000000				SHE_MID 00000000 00000000 00000000 00000000			
0xB0413020	SHE_IRQCLR 00000000 00000000 00000000 00000000				SHE_IRQEN 00000000 00000000 00000000 00000000			
0xB0413028	SHE_OMSTADDR 00000000 00000000 00000000 00000000				SHE_IMSTADDR 00000000 00000000 00000000 00000000			
0xB0413030	SHE_OMSTCNT 00000000 00000000 00000000 00000000				SHE_IMSTCNT 00000000 00000000 00000000 00000000			
0xB0413038	SHE_OMSTSTART 00000000 00000000 00000000 00000000				SHE_IMSTSTART 00000000 00000000 00000000 00000000			
0xB0413040	SHE_OFIFOCFG 00000000 00000001 00000000 00000000				SHE_IFIFOCFG 00000000 00000001 00000000 00000000			
0xB0413048	SHE_COMPARE1 00000111 11111111 11111111 11111111				SHE_COMPARE0 11111111 11111111 11111111 11111111			
0xB0413050	SHE_MSTSTATUS 00000000 00000001 00000000 00000001				SHE_COMPACC 00000000 00000000 00000000 00000000			
0xB0413058	SHE_OMSTERRADDR 00000000 00000000 00000000 00000000				SHE_IMSTERRADDR 00000000 00000000 00000000 00000000			

Table 32. Memory Layout of MEMORY_CONFIG Registers with Default Values (Continued)

Offset	+7	+6	+5	+4	+3	+2	+1	+0
0xB0413060	SHE_FIFOLOAD 00000000 00110000 00000000 00110000				SHE_FIFOSTATUS 00000000 00000000 00000000 00000000			
0xB0413068	SHE_DATACNT1 00000000 00000000 00000000 00000000				SHE_DATACNT0 00000000 00000000 00000000 00000000			
0xB0413070 - 0xB04130F8	read0 00000000 00000000 00000000 00000000				reserved 00000000 00000000 00000000 00000000			
0xB0413100	SHE_IFIFOWRDATA1 00000000 00000000 00000000 00000000				SHE_IFIFOWRDATA0 00000000 00000000 00000000 00000000			
0xB0413108	SHE_IFIFOWRDATA3 00000000 00000000 00000000 00000000				SHE_IFIFOWRDATA2 00000000 00000000 00000000 00000000			
0xB0413110	SHE_IFIFOWRDATA5 00000000 00000000 00000000 00000000				SHE_IFIFOWRDATA4 00000000 00000000 00000000 00000000			
0xB0413118	SHE_IFIFOWRDATA7 00000000 00000000 00000000 00000000				SHE_IFIFOWRDATA6 00000000 00000000 00000000 00000000			
0xB0413120	SHE_IFIFOWRDATA9 00000000 00000000 00000000 00000000				SHE_IFIFOWRDATA8 00000000 00000000 00000000 00000000			
0xB0413128	SHE_IFIFOWRDATA11 00000000 00000000 00000000 00000000				SHE_IFIFOWRDATA10 00000000 00000000 00000000 00000000			
0xB0413130	SHE_IFIFOWRDATA13 00000000 00000000 00000000 00000000				SHE_IFIFOWRDATA12 00000000 00000000 00000000 00000000			
0xB0413138	SHE_IFIFOWRDATA15 00000000 00000000 00000000 00000000				SHE_IFIFOWRDATA14 00000000 00000000 00000000 00000000			
0xB0413140	SHE_IFIFOWRDATA17 00000000 00000000 00000000 00000000				SHE_IFIFOWRDATA16 00000000 00000000 00000000 00000000			
0xB0413148	SHE_IFIFOWRDATA19 00000000 00000000 00000000 00000000				SHE_IFIFOWRDATA18 00000000 00000000 00000000 00000000			
0xB0413150	SHE_IFIFOWRDATA21 00000000 00000000 00000000 00000000				SHE_IFIFOWRDATA20 00000000 00000000 00000000 00000000			
0xB0413158	SHE_IFIFOWRDATA23 00000000 00000000 00000000 00000000				SHE_IFIFOWRDATA22 00000000 00000000 00000000 00000000			
0xB0413160	SHE_IFIFOWRDATA25 00000000 00000000 00000000 00000000				SHE_IFIFOWRDATA24 00000000 00000000 00000000 00000000			
0xB0413168	SHE_IFIFOWRDATA27 00000000 00000000 00000000 00000000				SHE_IFIFOWRDATA26 00000000 00000000 00000000 00000000			
0xB0413170	SHE_IFIFOWRDATA29 00000000 00000000 00000000 00000000				SHE_IFIFOWRDATA28 00000000 00000000 00000000 00000000			
0xB0413178	SHE_IFIFOWRDATA31 00000000 00000000 00000000 00000000				SHE_IFIFOWRDATA30 00000000 00000000 00000000 00000000			
0xB0413180	SHE_OFIFORDDATA1 00000000 00000000 00000000 00000000				SHE_OFIFORDDATA0 00000000 00000000 00000000 00000000			
0xB0413188	SHE_OFIFORDDATA3 00000000 00000000 00000000 00000000				SHE_OFIFORDDATA2 00000000 00000000 00000000 00000000			
0xB0413190	SHE_OFIFORDDATA5 00000000 00000000 00000000 00000000				SHE_OFIFORDDATA4 00000000 00000000 00000000 00000000			
0xB0413198	SHE_OFIFORDDATA7 00000000 00000000 00000000 00000000				SHE_OFIFORDDATA6 00000000 00000000 00000000 00000000			
0xB04131A0	SHE_OFIFORDDATA9 00000000 00000000 00000000 00000000				SHE_OFIFORDDATA8 00000000 00000000 00000000 00000000			
0xB04131A8	SHE_OFIFORDDATA11 00000000 00000000 00000000 00000000				SHE_OFIFORDDATA10 00000000 00000000 00000000 00000000			

Table 32. Memory Layout of MEMORY_CONFIG Registers with Default Values (Continued)

Offset	+7	+6	+5	+4	+3	+2	+1	+0
0xB04131B0	SHE_OFIFORDDATA13 00000000 00000000 00000000 00000000				SHE_OFIFORDDATA12 00000000 00000000 00000000 00000000			
0xB04131B8	SHE_OFIFORDDATA15 00000000 00000000 00000000 00000000				SHE_OFIFORDDATA14 00000000 00000000 00000000 00000000			
0xB04131C0	SHE_OFIFORDDATA17 00000000 00000000 00000000 00000000				SHE_OFIFORDDATA16 00000000 00000000 00000000 00000000			
0xB04131C8	SHE_OFIFORDDATA19 00000000 00000000 00000000 00000000				SHE_OFIFORDDATA18 00000000 00000000 00000000 00000000			
0xB04131D0	SHE_OFIFORDDATA21 00000000 00000000 00000000 00000000				SHE_OFIFORDDATA20 00000000 00000000 00000000 00000000			
0xB04131D8	SHE_OFIFORDDATA23 00000000 00000000 00000000 00000000				SHE_OFIFORDDATA22 00000000 00000000 00000000 00000000			
0xB04131E0	SHE_OFIFORDDATA25 00000000 00000000 00000000 00000000				SHE_OFIFORDDATA24 00000000 00000000 00000000 00000000			
0xB04131E8	SHE_OFIFORDDATA27 00000000 00000000 00000000 00000000				SHE_OFIFORDDATA26 00000000 00000000 00000000 00000000			
0xB04131F0	SHE_OFIFORDDATA29 00000000 00000000 00000000 00000000				SHE_OFIFORDDATA28 00000000 00000000 00000000 00000000			
0xB04131F8	SHE_OFIFORDDATA31 00000000 00000000 00000000 00000000				SHE_OFIFORDDATA30 00000000 00000000 00000000 00000000			
0xB0413200- B0413FF8	reserved XXXXXXXX XXXXXXXX XXXXXXXX XXXXXXXX XXXXXXXX XXXXXXXX XXXXXXXX XXXXXXXX							
0xB0414000	MPUXSHE0_NMIEN 00000000 00000000 00000000 00000001				MPUXSHE0_CTRL0 00000000 00000000 00000001 00000000			
0xB0414008	MPUXSHE0_WERRA XXXXXXXX XXXXXXXX XXXXXXXX XXXXXXXX				MPUXSHE0_WERRC 00000000 00000000 00000XXX XXXXXXX0			
0xB0414010	MPUXSHE0_RERRA XXXXXXXX XXXXXXXX XXXXXXXX XXXXXXXX				MPUXSHE0_RERRC 00000000 00000000 00000XXX XXXXXXX0			
0xB0414018	MPUXSHE0_SADDR1 00000000 00000000 00000000 00000000				MPUXSHE0_CTRL1 00000000 00000000 00000000 00000000			
0xB0414020	MPUXSHE0_CTRL2 00000000 00000000 00000000 00000000				MPUXSHE0_EADDR1 00000000 00000000 00000000 01111111			
0xB0414028	MPUXSHE0_EADDR2 00000000 00000000 00000000 01111111				MPUXSHE0_SADDR2 00000000 00000000 00000000 00000000			
0xB0414030	MPUXSHE0_SADDR3 00000000 00000000 00000000 00000000				MPUXSHE0_CTRL3 00000000 00000000 00000000 00000000			
0xB0414038	MPUXSHE0_CTRL4 00000000 00000000 00000000 00000000				MPUXSHE0_EADDR3 00000000 00000000 00000000 01111111			
0xB0414040	MPUXSHE0_EADDR4 00000000 00000000 00000000 01111111				MPUXSHE0_SADDR4 00000000 00000000 00000000 00000000			
0xB0414048	MPUXSHE0_SADDR5 00000000 00000000 00000000 00000000				MPUXSHE0_CTRL5 00000000 00000000 00000000 00000000			
0xB0414050	MPUXSHE0_CTRL6 00000000 00000000 00000000 00000000				MPUXSHE0_EADDR5 00000000 00000000 00000000 01111111			
0xB0414058	MPUXSHE0_EADDR6 00000000 00000000 00000000 01111111				MPUXSHE0_SADDR6 00000000 00000000 00000000 00000000			
0xB0414060	MPUXSHE0_SADDR7 00000000 00000000 00000000 00000000				MPUXSHE0_CTRL7 00000000 00000000 00000000 00000000			
0xB0414068	MPUXSHE0_CTRL8 00000000 00000000 00000000 00000000				MPUXSHE0_EADDR7 00000000 00000000 00000000 01111111			

Table 32. Memory Layout of MEMORY_CONFIG Registers with Default Values (Continued)

Offset	+7	+6	+5	+4	+3	+2	+1	+0
0xB0414070	MPUXSHE0_EADDR8 00000000 00000000 00000000 01111111				MPUXSHE0_SADDR8 00000000 00000000 00000000 00000000			
0xB0414078	MPUXSHE0_MID 00000000 00000000 00000000 00000000				MPUXSHE0_UNLOCK 00000000 00000000 00000000 00000000			
0xB0414080- B0417FF8	reserved XXXXXXXX XXXXXXXX XXXXXXXX XXXXXXXX XXXXXXXX XXXXXXXX XXXXXXXX XXXXXXXX							
0xB0418000	BSU6_BTST 00000000 00000000 00000000 00000000				reserved XXXXXXXX XXXXXXXX XXXXXXXX XXXXXXXX			
0xB0418008- B0418010	reserved XXXXXXXX XXXXXXXX XXXXXXXX XXXXXXXX XXXXXXXX XXXXXXXX XXXXXXXX XXXXXXXX							
0xB0418018	reserved XXXXXXXX XXXXXXXX XXXXXXXX XXXXXXXX				BSU6_PEN2 00000000 00000000 00000001 00000000			
0xB0418020	reserved XXXXXXXX XXXXXXXX XXXXXXXX XXXXXXXX				BSU6_PEN4 00000000 00000000 00000000 00000001			
0xB0418028- B0418038	reserved XXXXXXXX XXXXXXXX XXXXXXXX XXXXXXXX XXXXXXXX XXXXXXXX XXXXXXXX XXXXXXXX							
0xB0418040	reserved XXXXXXXX XXXXXXXX XXXXXXXX XXXXXXXX				BSU6_PEN12 00000000 00000000 00000000 00000001			
0xB0418048- B0418058	reserved XXXXXXXX XXXXXXXX XXXXXXXX XXXXXXXX XXXXXXXX XXXXXXXX XXXXXXXX XXXXXXXX							
0xB0418060	reserved XXXXXXXX XXXXXXXX XXXXXXXX XXXXXXXX				BSU6_PEN20 00000000 00000000 00000000 00000001			
0xB0418068- B04FFFF8	reserved XXXXXXXX XXXXXXXX XXXXXXXX XXXXXXXX XXXXXXXX XXXXXXXX XXXXXXXX XXXXXXXX							

Table 33. Memory Layout of DEBUG_BUS Registers with Default Values

Offset	+3	+2	+1	+0
0xB0500000- B050DFFC	reserved XXXXXXXX XXXXXXXX XXXXXXXX XXXXXXXX			
0xB050E000	MCFG_DTAR 000XX0X 000000XX 00000000 00000000			
0xB050E004	MCFG_TSR 00000000 00000000 00000000 00111011			
0xB050E008- B050F11C	reserved XXXXXXXX XXXXXXXX XXXXXXXX XXXXXXXX			
0xB050F120	SCCFG_TCFPUSRKEY0 00000000 00000000 00000000 00000000			
0xB050F124	SCCFG_TCFPUSRKEY1 00000000 00000000 00000000 00000000			
0xB050F128	SCCFG_TCFPUSRKEY2 00000000 00000000 00000000 00000000			
0xB050F12C	SCCFG_TCFPUSRKEY3 00000000 00000000 00000000 00000000			
0xB050F130	SCCFG_EEFUSRKEY0 00000000 00000000 00000000 00000000			
0xB050F134	SCCFG_EEFUSRKEY1 00000000 00000000 00000000 00000000			
0xB050F138	SCCFG_EEFUSRKEY2 00000000 00000000 00000000 00000000			
0xB050F13C	SCCFG_EEFUSRKEY3 00000000 00000000 00000000 00000000			
0xB050F140- B050F16C	reserved XXXXXXXX XXXXXXXX XXXXXXXX XXXXXXXX			
0xB050F170	SCCFG_CTRL 00000000 00000000 00000000 00000000			
0xB050F174	reserved XXXXXXXX XXXXXXXX XXXXXXXX XXXXXXXX			
0xB050F178	SCCFG_STAT0 00000000 00000000 00000000 00000000			
0xB050F17C	SCCFG_STAT1 00000001 0000000X 00000000 00111111			
0xB050F180	SCCFG_STAT2 00000000 00000000 00000000 00000101			
0xB050F184- B050F18C	reserved XXXXXXXX XXXXXXXX XXXXXXXX XXXXXXXX			
0xB050F190	SCCFG_SECKEY0 00000000 00000000 00000000 00000000			
0xB050F194	SCCFG_SECKEY1 00000000 00000000 00000000 00000000			
0xB050F198	SCCFG_SECKEY2 00000000 00000000 00000000 00000000			

Table 33. Memory Layout of DEBUG_BUS Registers with Default Values (Continued)

Offset	+3	+2	+1	+0
0xB050F19C	SCCFG_SECKEY3 00000000 00000000 00000000 00000000			
0xB050F1A0	SCCFG_MODID 00000000 00000000 00000000 00000000			
0xB050F1A4	SCCFG_UNLCK 00000000 00000000 00000000 00000000			
0xB050F1A8	SCCFG_GPREG0 00000000 00000000 00000000 00000000			
0xB050F1AC	SCCFG_GPREG1 00000000 00000000 00000000 00000000			
0xB050F1B0- B05FFFFC	reserved XXXXXXXX XXXXXXXX XXXXXXXX XXXXXXXX			

Table 34. Memory Layout of MCU_CONFIG Registers with Default Values

Offset	+3	+2	+1	+0
0xB060000	SYSC_PROTKEYR 00000000 00000000 00000000 00000000			
0xB0600004- B060007C	reserved XXXXXXXX XXXXXXXX XXXXXXXX XXXXXXXX			
0xB0600080	SYSC_RUNCKSRER 00000000 00001110		SYSC_RUNPDCFGR 00000000 00001111	
0xB0600084	SYSC_RUNCKSELR 00100011 00000000 00000000 00000000			
0xB0600088	SYSC_RUNCKER 01110001 00111111 00001101 11110001			
0xB060008C	SYSC_RUNCKDIVR0 00000000 00000000 00000000 00000000			
0xB0600090	SYSC_RUNCKDIVR1 00000000 00000000 00000000 00000000			
0xB0600094	SYSC_RUNCKDIVR2 00000000 00000000 00000000 00000000			
0xB0600098	SYSC_RUNPLLCTR 00000000 00001101 00000001 00000000			
0xB060009C	SYSC_RUNSSCGCNTRO 00000001 00001101 00000001 00000000			
0xB06000A0	SYSC_RUNSSCGCNT1 00000000 00000000 00000000 00101001			
0xB06000A4	SYSC_RUNGFXCNTRO 00000001 00001101 00000000 00000000			
0xB06000A8	SYSC_RUNGFXCNT1 00000000 00000000 00000000 00101001			
0xB06000AC	SYSC_RUNLVDCFGR 00000000 00001011 00001110 00001111			
0xB06000B0	SYSC_TRGRUNCNTR 00000000 00000000		SYSC_RUNCSVCFGR 00000000 00000000	
0xB06000B4- B06000FC	reserved XXXXXXXX XXXXXXXX XXXXXXXX XXXXXXXX			
0xB0600100	SYSC_PSSCKSRER 00000000 00001110		SYSC_PSSPDCFGR 00000000 00001111	
0xB0600104	SYSC_PSSCKSELR 00100011 00000000 00000000 00000000			
0xB0600108	SYSC_PSSCKER 01110001 00111110 00001101 11110001			
0xB060010C	SYSC_PSSCKDIVR0 00000000 00000000 00000000 00000000			
0xB0600110	SYSC_PSSCKDIVR1 00000000 00000000 00000000 00000000			
0xB0600114	SYSC_PSSCKDIVR2 00000000 00000000 00000000 00000000			
0xB0600118	SYSC_PSSPLLCTR 00000000 00001101 00000001 00000000			
0xB060011C	SYSC_PSSSSCGCNTRO 00000001 00001101 00000001 00000000			
0xB0600120	SYSC_PSSSSCGCNT1 00000000 00000000 00000000 00101001			
0xB0600124	SYSC_PSSGFXCNTRO 00000001 00001101 00000000 00000000			

Table 34. Memory Layout of MCU_CONFIG Registers with Default Values (Continued)

Offset	+3	+2	+1	+0
0xB0600128	SYSC_PSSGFXCNTR1 00000000 00000000 00000000 00101001			
0xB060012C	SYSC_PSSLVDCFGR 00000000 00001011 00001110 00001111			
0xB0600130	SYSC_PSENR 00000000 00000000	SYSC_PSSCVCFGR 00000000 00000000		
0xB0600134- B060017C	reserved XXXXXXXX XXXXXXXX XXXXXXXX XXXXXXXX			
0xB0600180	SYSC_APPCKSRER 00000000 00001110	SYSC_APPPDCFGR 00000000 00001111		
0xB0600184	SYSC_APPCKSELR 00100011 00000000 00000000 00000000			
0xB0600188	SYSC_APPCKER 01110001 00111111 00001101 11110001			
0xB060018C	SYSC_APPCKDIVR0 00000000 00000000 00000000 00000000			
0xB0600190	SYSC_APPCKDIVR1 00000000 00000000 00000000 00000000			
0xB0600194	SYSC_APPCKDIVR2 00000000 00000000 00000000 00000000			
0xB0600198	SYSC_APPLLCNTR 00000000 00001101 00000001 00000000			
0xB060019C	SYSC_APPSSGCNTR0 00000001 00001101 00000001 00000000			
0xB06001A0	SYSC_APPSSGCNTR1 00000000 00000000 00000000 00101001			
0xB06001A4	SYSC_APPGFXCNTR0 00000001 00001101 00000000 00000000			
0xB06001A8	SYSC_APPGFXCNTR1 00000000 00000000 00000000 00101001			
0xB06001AC	SYSC_APPLVDCFGR 00000000 00001011 00001110 00001111			
0xB06001B0	reserved XXXXXXXX XXXXXXXX	SYSC_APPCSVCFGR 00000000 00000000		
0xB06001B4- B06001FC	reserved XXXXXXXX XXXXXXXX XXXXXXXX XXXXXXXX			
0xB0600200	SYSC_CKSRESTSR 00000000 00001110	SYSC_PDSTSR 00000000 00001111		
0xB0600204	SYSC_CKSELSTSR 00100011 00000000 00000000 00000000			
0xB0600208	SYSC_CKESTSR 01110001 00111111 00001101 11110001			
0xB060020C	SYSC_CKDIVSTSR0 00000000 00000000 00000000 00000000			
0xB0600210	SYSC_CKDIVSTSR1 00000000 00000000 00000000 00000000			
0xB0600214	SYSC_CKDIVSTSR2 00000000 00000000 00000000 00000000			
0xB0600218	SYSC_PLLSTSR 00000000 00001101 00000001 00000000			
0xB060021C	SYSC_SSCGSTSR0 00000001 00001101 00000001 00000000			

Table 34. Memory Layout of MCU_CONFIG Registers with Default Values (Continued)

Offset	+3	+2	+1	+0
0xB0600220	SYSC_SSCGSTR1 00000000 00000000 00000000 00101001			
0xB0600224	SYSC_GFXSTR0 00000001 00001101 00000000 00000000			
0xB0600228	SYSC_GFXSTR1 00000000 00000000 00000000 00101001			
0xB060022C	SYSC_LVDCFGSTR 00000000 00101011 00101110 00101111			
0xB0600230	reserved XXXXXXXX XXXXXXXX	SYSC_CSVCFGSTR 00000000 00000000		
0xB0600234- B060027C	reserved XXXXXXXX XXXXXXXX XXXXXXXX XXXXXXXX			
0xB0600280	SYSC_SYSIDR XXXXXXXX XXXXXXXX XXXXXXXX XXXXXXXX			
0xB0600284	SYSC_SYSSTR 00000000 00000000 0000100 00000000			
0xB0600288	SYSC_SYSINTER 00000000 00000000 00000000 00000000			
0xB060028C	SYSC_SYSICLR 00000000 00000000 00000000 00000000			
0xB0600290	SYSC_SYSERRR 00000000 00000000 00000000 00000000			
0xB0600294	SYSC_SYSERRICLR 00000000 00000000 00000000 00000000			
0xB0600298- B06002FC	reserved XXXXXXXX XXXXXXXX XXXXXXXX XXXXXXXX			
0xB0600300	SYSC_CSMOCFGR 00000000 00000000 00000000 00000000			
0xB0600304	SYSC_CSVSOCFGR 00000000 00000000 00000000 00000000			
0xB0600308	SYSC_CSMPCFGR 00000000 00000000 00000000 00000000			
0xB060030C	SYSC_CSVSPCFGR 00000000 00000000 00000000 00000000			
0xB0600310	SYSC_CSVGPCFGR 00000000 00000000 00000000 00000000			
0xB0600314	SYSC_CSVTESTR 00000000 00000000 00000000 00000000			
0xB0600318- B060037C	reserved XXXXXXXX XXXXXXXX XXXXXXXX XXXXXXXX			
0xB0600380	SYSC_RSTCNTR 00000000 00000000 00000000 00000000			
0xB0600384	SYSC_RSTCAUSEUR 00011110 00000000 00000000 00000001			
0xB0600388	SYSC_RSTCAUSEBT X0011110 00000000 00000000 00000001			
0xB060038C- B06003FC	reserved XXXXXXXX XXXXXXXX XXXXXXXX XXXXXXXX			
0xB0600400	SYSC_SRCSTRG 00000000 00000000 00000000 00000000			
0xB0600404	SYSC_SRCSTCNTR 00000000 00000000 00000000 00000000			

Table 34. Memory Layout of MCU_CONFIG Registers with Default Values (Continued)

Offset	+3	+2	+1	+0
0xB0600408		SYSC_SRCSTCPR 00000000 00000110 00000000 00000001		
0xB060040C		SYSC_SRCSTSTATR 00000000 00000000 00000000 00000000		
0xB0600410		SYSC_SRCSTINTER 00000000 00000000 00000000 00000000		
0xB0600414		SYSC_SRCSTICLR 00000000 00000000 00000000 00000000		
0xB0600418- B060047C		reserved XXXXXXXX XXXXXXXX XXXXXXXX XXXXXXXX		
0xB0600480		SYSC_RCSCTTRG 00000000 00000000 00000000 00000000		
0xB0600484		SYSC_RCSCTCNTR 00000000 00000000 00000000 00000000		
0xB0600488		SYSC_RCSCTCPR 00000000 00000110 00000000 00011110		
0xB060048C		SYSC_RCSCTSTATR 00000000 00000000 00000000 00000000		
0xB0600490		SYSC_RCSCTINTER 00000000 00000000 00000000 00000000		
0xB0600494		SYSC_RCSCTICLR 00000000 00000000 00000000 00000000		
0xB0600498- B06004FC		reserved XXXXXXXX XXXXXXXX XXXXXXXX XXXXXXXX		
0xB0600500		SYSC_MAINSCTTRG 00000000 00000000 00000000 00000000		
0xB0600504		SYSC_MAINSCTCNTR 00000000 00000000 00000000 00000000		
0xB0600508		SYSC_MAINSCTCPR 00000000 00000110 00010000 00000000		
0xB060050C		SYSC_MAINSCTSTATR 00000000 00000000 00000000 00000000		
0xB0600510		SYSC_MAINSCTINTER 00000000 00000000 00000000 00000000		
0xB0600514		SYSC_MAINSCTICLR 00000000 00000000 00000000 00000000		
0xB0600518- B060057C		reserved XXXXXXXX XXXXXXXX XXXXXXXX XXXXXXXX		
0xB0600580		SYSC_SUBSCTTRG 00000000 00000000 00000000 00000000		
0xB0600584		SYSC_SUBSCTCNTR 00000000 00000000 00000000 00000000		
0xB0600588		SYSC_SUBSCTCPR 00000000 00000110 00000100 00000000		
0xB060058C		SYSC_SUBSCTSTATR 00000000 00000000 00000000 00000000		
0xB0600590		SYSC_SUBSCTINTER 00000000 00000000 00000000 00000000		
0xB0600594		SYSC_SUBSCTICLR 00000000 00000000 00000000 00000000		
0xB0600598- B06005FC		reserved XXXXXXXX XXXXXXXX XXXXXXXX XXXXXXXX		

Table 34. Memory Layout of MCU_CONFIG Registers with Default Values (Continued)

Offset	+3	+2	+1	+0
0xB0600600	SYSC_CKOTCFGR 00000000 00000000 00000000 00000111			
0xB0600604- B060067C	reserved XXXXXXXX XXXXXXXX XXXXXXXX XXXXXXXX			
0xB0600680	SYSC_SPCCFGR 00000000 000000X0 00000000 00000000			
0xB0600684	SYSC_RCCFGR 00000000 00000000 00000001 11111111			
0xB0600688	SYSC_TESTR0 00000000 00000000 00000000 00000000			
0xB060068C	SYSC_TESTR1 00000000 00000000 00000000 00000000			
0xB0600690	SYSC_TESTR2 00000000 00000000 00000000 00000000			
0xB0600694- B06006FC	reserved XXXXXXXX XXXXXXXX XXXXXXXX XXXXXXXX			
0xB0600700	SYSC_JTAGDETECT 00000000 00000000 00000000 00000000			
0xB0600704	SYSC_JTAGCNFG 00000000 00000000 00000000 00000001			
0xB0600708	SYSC_JTAGWAKEUP 00000000 00000000 00000000 00000001			
0xB060070C- B0607FFC	reserved XXXXXXXX XXXXXXXX XXXXXXXX XXXXXXXX			
0xB0608000	WDG_PROT 00000000 00000000 00000000 00000000			
0xB0608004	reserved 00000000 00000000 00000000 00000000			
0xB0608008	WDG_CNT 00000000 00000000 00000000 00000000			
0xB060800C	WDG_RSTCAUSE 00000000 00000000 00000000 00XXXXXX			
0xB0608010	WDG_TRG0 00000000 00000000 00000000 00000000			
0xB0608014	reserved 00000000 00000000 00000000 00000000			
0xB0608018	WDG_TRG1 00000000 00000000 00000000 00000000			
0xB060801C	reserved 00000000 00000000 00000000 00000000			
0xB0608020	WDG_INT 00000000 00000000 00000000 00000000			
0xB0608024	WDG_INTCLR 00000000 00000000 00000000 00000000			
0xB0608028	reserved 00000000 00000000 00000000 00000000			
0xB060802C	WDG_TRG0CFG 00000000 00000000 00000000 00000000			
0xB0608030	WDG_TRG1CFG 00000000 00000000 00000000 00000000			
0xB0608034	WDG_RUNLL 00000000 00000000 00000000 00000000			

Table 34. Memory Layout of MCU_CONFIG Registers with Default Values (Continued)

Offset	+3	+2	+1	+0
0xB0608038		WDG_RUNUL 00000001 00000000 00000000 00000000		
0xB060803C		WDG_PSSLL 00000000 00000000 00000000 00000000		
0xB0608040		WDG_PSSUL 10000000 00000000 00000000 00000000		
0xB0608044		WDG_RSTDLY 00000000 00000000 00000000 00000000		
0xB0608048		WDG_CFG 00000000 00000000 00000000 00000011		
0xB060804C- B060FFFC		reserved XXXXXXXX XXXXXXXX XXXXXXXX XXXXXXXX		
0xB0610000		RRCFG_UNLOCKR 00000000 00000000 00000000 00000000		
0xB0610004		RRCFG_CSR 00001111 00000000 00000010 00000000		
0xB0610008		RRCFG_EAN 00000000 00000000 00000000 00000000		
0xB061000C		RRCFG_ERRMSKR0 00000000 00000000 00000000 00000000		
0xB0610010		RRCFG_ERRMSKR1 00000000 00000000 00000000 00000000		
0xB0610014		RRCFG_ECCEN 00000000 00000000 00000000 00000001		
0xB0610018- B0617FFC		reserved XXXXXXXX XXXXXXXX XXXXXXXX XXXXXXXX		
0xB0618000		RTC_WTCR 00000000 00000000 00000000 00000000		
0xB0618004		RTC_WTSR 00000000 00000000 00000000 00000000		
0xB0618008		RTC_WINS 00000000 00000000 00000000 00000000		
0xB061800C		RTC_WINE 00000000 00000000 00000000 00000000		
0xB0618010		RTC_WINC 00000000 00000000 00000000 00000000		
0xB0618014		RTC_WTBR 00000000 00000000 00000000 00000000		
0xB0618018		RTC_WRT 00000000 00000000 00000000 00000000		
0xB061801C		RTC_CNTCAL 00000000 00000000 00000000 00000000		
0xB0618020		RTC_CNTPCAL 00000000 00000000 00000000 00000000		
0xB0618024		RTC_DURMW 00000000 00000000 00000000 00000000		
0xB0618028		RTC_CALTRG 00000000 00000000 00000000 00000000		
0xB061802C		RTC_DEBUG 00000000 00000000 00000000 00000000		
0xB0618030- B061FFFC		reserved 00000000 00000000 00000000 0000000X		

Table 34. Memory Layout of MCU_CONFIG Registers with Default Values (Continued)

Offset	+3	+2	+1	+0
0xB0620000	EIC0_ENIR 00000000 00000000 00000000 00000000			
0xB0620004	EIC0_ENISR 00000000 00000000 00000000 00000000			
0xB0620008	EIC0_ENICR 00000000 00000000 00000000 00000000			
0xB062000C	EIC0_EIRR XXXXXXXX XXXXXXXX XXXXXXXX XXXXXXXX			
0xB0620010	EIC0_EIRCR 00000000 00000000 00000000 00000000			
0xB0620014	EIC0_NFER 00000000 00000000 00000000 00000000			
0xB0620018	EIC0_NFESR 00000000 00000000 00000000 00000000			
0xB062001C	EIC0_NFECR 00000000 00000000 00000000 00000000			
0xB0620020	EIC0_ELVR0 00000000 00000000 00000000 00000000			
0xB0620024	EIC0_ELVR1 00000000 00000000 00000000 00000000			
0xB0620028	EIC0_ELVR2 00000000 00000000 00000000 00000000			
0xB062002C	EIC0_ELVR3 00000000 00000000 00000000 00000000			
0xB0620030	EIC0_NMIR 00000000 00000000 00000000 00000000			
0xB0620034	EIC0_DRER 00000000 00000000 00000000 00000000			
0xB0620038	EIC0_DRESR 00000000 00000000 00000000 00000000			
0xB062003C	EIC0_DRECR 00000000 00000000 00000000 00000000			
0xB0620040	EIC0_DRFR 00000000 00000000 00000000 00000000			
0xB0620044- B0627FFC	reserved XXXXXXXX XXXXXXXX XXXXXXXX XXXXXXXX			
0xB0628000	EICU0_CNFR 00000000 00000000 00000000 00000000			
0xB0628004	EICU0_IREN 00000000 00000000 00000000 00000000			
0xB0628008	EICU0_SPLR0 00000000 00000000 00000000 00000000			
0xB062800C	EICU0_SPLR1 00000000 00000000 00000000 00000000			
0xB0628010	EICU0_SPLR2 00000000 00000000 00000000 00000000			
0xB0628014	EICU0_SPLR3 00000000 00000000 00000000 00000000			
0xB0628018	EICU0_SPLR4 00000000 00000000 00000000 00000000			
0xB062801C	EICU0_SPLR5 00000000 00000000 00000000 00000000			

Table 34. Memory Layout of MCU_CONFIG Registers with Default Values (Continued)

Offset	+3	+2	+1	+0
0xB0628020	EICU0_SPLR6 00000000 00000000 00000000 00000000			
0xB0628024	EICU0_SPLR7 00000000 00000000 00000000 00000000			
0xB0628028- B06F7FFC	reserved XXXXXXXX XXXXXXXX XXXXXXXX XXXXXXXX			
0xB06F8000	read0 00000000 00000000		RICFG7_GFX0DCLKI 00000000 00000000	
0xB06F8004- B06F8FFC	reserved 00000000 00000000 00000000 00000000			
0xB06F9000	read0 00000000 00000000		RICFG7_EIC0INT00 00000000 00000000	
0xB06F9004	read0 00000000 00000000		RICFG7_EIC0INT01 00000000 00000000	
0xB06F9008	read0 00000000 00000000		RICFG7_EIC0INT02 00000000 00000000	
0xB06F900C	read0 00000000 00000000		RICFG7_EIC0INT03 00000000 00000000	
0xB06F9010	read0 00000000 00000000		RICFG7_EIC0INT04 00000000 00000000	
0xB06F9014	read0 00000000 00000000		RICFG7_EIC0INT05 00000000 00000000	
0xB06F9018	read0 00000000 00000000		RICFG7_EIC0INT06 00000000 00000000	
0xB06F901C	read0 00000000 00000000		RICFG7_EIC0INT07 00000000 00000000	
0xB06F9020	read0 00000000 00000000		RICFG7_EIC0INT08 00000000 00000000	
0xB06F9024	read0 00000000 00000000		RICFG7_EIC0INT09 00000000 00000000	
0xB06F9028	read0 00000000 00000000		RICFG7_EIC0INT10 00000000 00000000	
0xB06F902C	read0 00000000 00000000		RICFG7_EIC0INT11 00000000 00000000	
0xB06F9030	read0 00000000 00000000		RICFG7_EIC0INT12 00000000 00000000	
0xB06F9034	read0 00000000 00000000		RICFG7_EIC0INT13 00000000 00000000	
0xB06F9038	read0 00000000 00000000		RICFG7_EIC0INT14 00000000 00000000	
0xB06F903C	read0 00000000 00000000		RICFG7_EIC0INT15 00000000 00000000	
0xB06F9040	read0 00000000 00000000		RICFG7_EIC0INT16 00000000 00000000	
0xB06F9044	read0 00000000 00000000		RICFG7_EIC0INT17 00000000 00000000	
0xB06F9048	read0 00000000 00000000		RICFG7_EIC0INT18 00000000 00000000	
0xB06F904C	read0 00000000 00000000		RICFG7_EIC0INT19 00000000 00000000	

Table 34. Memory Layout of MCU_CONFIG Registers with Default Values (Continued)

Offset	+3	+2	+1	+0
0xB06F9050	read0 00000000 00000000			RICFG7_EIC0INT20 00000000 00000000
0xB06F9054	read0 00000000 00000000			RICFG7_EIC0INT21 00000000 00000000
0xB06F9058	read0 00000000 00000000			RICFG7_EIC0INT22 00000000 00000000
0xB06F905C	read0 00000000 00000000			RICFG7_EIC0INT23 00000000 00000000
0xB06F9060	read0 00000000 00000000			RICFG7_EIC0INT24 00000000 00000000
0xB06F9064	read0 00000000 00000000			RICFG7_EIC0INT25 00000000 00000000
0xB06F9068	read0 00000000 00000000			RICFG7_EIC0INT26 00000000 00000000
0xB06F906C	read0 00000000 00000000			RICFG7_EIC0INT27 00000000 00000000
0xB06F9070	read0 00000000 00000000			RICFG7_EIC0INT28 00000000 00000000
0xB06F9074	read0 00000000 00000000			RICFG7_EIC0INT29 00000000 00000000
0xB06F9078	read0 00000000 00000000			RICFG7_EIC0INT30 00000000 00000000
0xB06F907C	read0 00000000 00000000			RICFG7_EIC0INT31 00000000 00000000
0xB06F9080	read0 00000000 00000000			RICFG7_EIC0NMI 00000000 00000000
0xB06F9084- B06FFC00	reserved XXXXXXXX XXXXXXXX XXXXXXXX XXXXXXXX			
0xB06FFC04	BSU7_BTST 00000000 00000000 00000000 00000000			
0xB06FFC08- B06FFC18	reserved XXXXXXXX XXXXXXXX XXXXXXXX XXXXXXXX			
0xB06FFC1C	BSU7_PEN3 00000000 00000000 00000000 00000000			
0xB06FFC20	reserved XXXXXXXX XXXXXXXX XXXXXXXX XXXXXXXX			
0xB06FFC24	BSU7_PEN5 00000000 00000000 00000000 00000000			
0xB06FFC28	reserved XXXXXXXX XXXXXXXX XXXXXXXX XXXXXXXX			
0xB06FFC2C	BSU7_PEN7 00000000 00000000 00000000 00000000			
0xB06FFC30	BSU7_PEN8 00000000 00000000 00000000 00000000			
0xB06FFC34- B06FFFC	reserved XXXXXXXX XXXXXXXX XXXXXXXX XXXXXXXX			

Table 35. Memory Layout of PERI0_RBUS Registers with Default Values

Offset	+1	+0
0xB0700000	ADC0_ER32 00000000 00000000	
0xB0700002	ADC0_ER10 00000000 00000000	
0xB0700004	ADC0_CS1 00000000	ADC0_CS0 00000000
0xB0700006	ADC0_CS3 00000000	ADC0_CS2 00000000
0xB0700008	ADC0_CSS1 00000000	reserved XXXXXXXX
0xB070000A	ADC0_CSC1 00000000	reserved XXXXXXXX
0xB070000C	ADC0_CSS3 00000000	reserved XXXXXXXX
0xB070000E	ADC0_CSC3 00000000	reserved XXXXXXXX
0xB0700010	ADC0_CR 000000XX XXXXXXXX	
0xB0700012	reserved XXXXXXXX	reserved XXXXXXXX
0xB0700014	reserved XXXXXXXX	reserved XXXXXXXX
0xB0700016	reserved XXXXXXXX	reserved XXXXXXXX
0xB0700018	ADC0_CD0 000000XX XXXXXXXX	
0xB070001A	ADC0_CD1 000000XX XXXXXXXX	
0xB070001C	ADC0_CD2 000000XX XXXXXXXX	
0xB070001E	ADC0_CD3 000000XX XXXXXXXX	
0xB0700020	ADC0_CD4 000000XX XXXXXXXX	
0xB0700022	ADC0_CD5 000000XX XXXXXXXX	
0xB0700024	ADC0_CD6 000000XX XXXXXXXX	
0xB0700026	ADC0_CD7 000000XX XXXXXXXX	
0xB0700028	ADC0_CD8 000000XX XXXXXXXX	
0xB070002A	ADC0_CD9 000000XX XXXXXXXX	
0xB070002C	ADC0_CD10 000000XX XXXXXXXX	
0xB070002E	ADC0_CD11 000000XX XXXXXXXX	
0xB0700030	ADC0_CD12 000000XX XXXXXXXX	

Table 35. Memory Layout of PERI0_RBUS Registers with Default Values (Continued)

Offset	+1	+0
0xB0700032	ADC0_CD13 000000XX XXXXXXXX	
0xB0700034	ADC0_CD14 000000XX XXXXXXXX	
0xB0700036	ADC0_CD15 000000XX XXXXXXXX	
0xB0700038	ADC0_CD16 000000XX XXXXXXXX	
0xB070003A	ADC0_CD17 000000XX XXXXXXXX	
0xB070003C	ADC0_CD18 000000XX XXXXXXXX	
0xB070003E	ADC0_CD19 000000XX XXXXXXXX	
0xB0700040	ADC0_CD20 000000XX XXXXXXXX	
0xB0700042	ADC0_CD21 000000XX XXXXXXXX	
0xB0700044	ADC0_CD22 000000XX XXXXXXXX	
0xB0700046	ADC0_CD23 000000XX XXXXXXXX	
0xB0700048	ADC0_CD24 000000XX XXXXXXXX	
0xB070004A	ADC0_CD25 000000XX XXXXXXXX	
0xB070004C	ADC0_CD26 000000XX XXXXXXXX	
0xB070004E	ADC0_CD27 000000XX XXXXXXXX	
0xB0700050	ADC0_CD28 000000XX XXXXXXXX	
0xB0700052	ADC0_CD29 000000XX XXXXXXXX	
0xB0700054	ADC0_CD30 000000XX XXXXXXXX	
0xB0700056	ADC0_CD31 000000XX XXXXXXXX	
0xB0700058	reserved XXXXXXXX	reserved XXXXXXXX
0xB070005A	reserved XXXXXXXX	reserved XXXXXXXX
0xB070005C	reserved XXXXXXXX	reserved XXXXXXXX
0xB070005E	ADC0_CT 00010000 00101100	
0xB0700060	ADC0_ECH 00000000	ADC0_SCH 00000000
0xB0700062	reserved XXXXXXXX	ADC0_MAR 00000000
0xB0700064	reserved XXXXXXXX	ADC0_MACR 00000000

Table 35. Memory Layout of PERI0_RBUS Registers with Default Values (Continued)

Offset	+1	+0
0xB0700066	reserved XXXXXXXX	ADC0_MASR 00000000
0xB0700068	ADC0_RCOH0 11111111	ADC0_RCOL0 00000000
0xB070006A	ADC0_RCOH1 11111111	ADC0_RCOL1 00000000
0xB070006C	ADC0_RCOH2 11111111	ADC0_RCOL2 00000000
0xB070006E	ADC0_RCOH3 11111111	ADC0_RCOL3 00000000
0xB0700070	ADC0_CC1 00000000	ADC0_CC0 00000000
0xB0700072	ADC0_CC3 00000000	ADC0_CC2 00000000
0xB0700074	ADC0_CC5 00000000	ADC0_CC4 00000000
0xB0700076	ADC0_CC7 00000000	ADC0_CC6 00000000
0xB0700078	ADC0_CC9 00000000	ADC0_CC8 00000000
0xB070007A	ADC0_CC11 00000000	ADC0_CC10 00000000
0xB070007C	ADC0_CC13 00000000	ADC0_CC12 00000000
0xB070007E	ADC0_CC15 00000000	ADC0_CC14 00000000
0xB0700080	ADC0_RCOIRS32 00000000 00000000	
0xB0700082	ADC0_RCOIRS10 00000000 00000000	
0xB0700084	ADC0_RCOOF32 00000000 00000000	
0xB0700086	ADC0_RCOOF10 00000000 00000000	
0xB0700088	ADC0_RCOINT32 00000000 00000000	
0xB070008A	ADC0_RCOINT10 00000000 00000000	
0xB070008C	ADC0_RCOINTC32 00000000 00000000	
0xB070008E	ADC0_RCOINTC10 00000000 00000000	
0xB0700090	ADC0_PCTNRL0 00000000	ADC0_PCTPRL0 00000000
0xB0700092	ADC0_PCTNCT0 00000000	ADC0_PCTPCT0 00000000
0xB0700094	ADC0_PCTNRL1 00000000	ADC0_PCTPRL1 00000000
0xB0700096	ADC0_PCTNCT1 00000000	ADC0_PCTPCT1 00000000

Table 35. Memory Layout of PERI0_RBUS Registers with Default Values (Continued)

Offset	+1	+0
0xB0700098	ADC0_PCTNRL2 00000000	ADC0_PCTPRL2 00000000
0xB070009A	ADC0_PCTNCT2 00000000	ADC0_PCTPCT2 00000000
0xB070009C	ADC0_PCTNRL3 00000000	ADC0_PCTPRL3 00000000
0xB070009E	ADC0_PCTNCT3 00000000	ADC0_PCTPCT3 00000000
0xB07000A0	ADC0_PCTNRL4 00000000	ADC0_PCTPRL4 00000000
0xB07000A2	ADC0_PCTNCT4 00000000	ADC0_PCTPCT4 00000000
0xB07000A4	ADC0_PCTNRL5 00000000	ADC0_PCTPRL5 00000000
0xB07000A6	ADC0_PCTNCT5 00000000	ADC0_PCTPCT5 00000000
0xB07000A8	ADC0_PCTNRL6 00000000	ADC0_PCTPRL6 00000000
0xB07000AA	ADC0_PCTNCT6 00000000	ADC0_PCTPCT6 00000000
0xB07000AC	ADC0_PCTNRL7 00000000	ADC0_PCTPRL7 00000000
0xB07000AE	ADC0_PCTNCT7 00000000	ADC0_PCTPCT7 00000000
0xB07000B0	ADC0_PCTNRL8 00000000	ADC0_PCTPRL8 00000000
0xB07000B2	ADC0_PCTNCT8 00000000	ADC0_PCTPCT8 00000000
0xB07000B4	ADC0_PCTNRL9 00000000	ADC0_PCTPRL9 00000000
0xB07000B6	ADC0_PCTNCT9 00000000	ADC0_PCTPCT9 00000000
0xB07000B8	ADC0_PCTNRL10 00000000	ADC0_PCTPRL10 00000000
0xB07000BA	ADC0_PCTNCT10 00000000	ADC0_PCTPCT10 00000000
0xB07000BC	ADC0_PCTNRL11 00000000	ADC0_PCTPRL11 00000000
0xB07000BE	ADC0_PCTNCT11 00000000	ADC0_PCTPCT11 00000000
0xB07000C0	ADC0_PCTNRL12 00000000	ADC0_PCTPRL12 00000000
0xB07000C2	ADC0_PCTNCT12 00000000	ADC0_PCTPCT12 00000000
0xB07000C4	ADC0_PCTNRL13 00000000	ADC0_PCTPRL13 00000000
0xB07000C6	ADC0_PCTNCT13 00000000	ADC0_PCTPCT13 00000000
0xB07000C8	ADC0_PCTNRL14 00000000	ADC0_PCTPRL14 00000000

Table 35. Memory Layout of PERI0_RBUS Registers with Default Values (Continued)

Offset	+1	+0
0xB07000CA	ADC0_PCTNCT14 00000000	ADC0_PCTPCT14 00000000
0xB07000CC	ADC0_PCTNRL15 00000000	ADC0_PCTPRL15 00000000
0xB07000CE	ADC0_PCTNCT15 00000000	ADC0_PCTPCT15 00000000
0xB07000D0	ADC0_PCTNRL16 00000000	ADC0_PCTPRL16 00000000
0xB07000D2	ADC0_PCTNCT16 00000000	ADC0_PCTPCT16 00000000
0xB07000D4	ADC0_PCTNRL17 00000000	ADC0_PCTPRL17 00000000
0xB07000D6	ADC0_PCTNCT17 00000000	ADC0_PCTPCT17 00000000
0xB07000D8	ADC0_PCTNRL18 00000000	ADC0_PCTPRL18 00000000
0xB07000DA	ADC0_PCTNCT18 00000000	ADC0_PCTPCT18 00000000
0xB07000DC	ADC0_PCTNRL19 00000000	ADC0_PCTPRL19 00000000
0xB07000DE	ADC0_PCTNCT19 00000000	ADC0_PCTPCT19 00000000
0xB07000E0	ADC0_PCTNRL20 00000000	ADC0_PCTPRL20 00000000
0xB07000E2	ADC0_PCTNCT20 00000000	ADC0_PCTPCT20 00000000
0xB07000E4	ADC0_PCTNRL21 00000000	ADC0_PCTPRL21 00000000
0xB07000E6	ADC0_PCTNCT21 00000000	ADC0_PCTPCT21 00000000
0xB07000E8	ADC0_PCTNRL22 00000000	ADC0_PCTPRL22 00000000
0xB07000EA	ADC0_PCTNCT22 00000000	ADC0_PCTPCT22 00000000
0xB07000EC	ADC0_PCTNRL23 00000000	ADC0_PCTPRL23 00000000
0xB07000EE	ADC0_PCTNCT23 00000000	ADC0_PCTPCT23 00000000
0xB07000F0	ADC0_PCTNRL24 00000000	ADC0_PCTPRL24 00000000
0xB07000F2	ADC0_PCTNCT24 00000000	ADC0_PCTPCT24 00000000
0xB07000F4	ADC0_PCTNRL25 00000000	ADC0_PCTPRL25 00000000
0xB07000F6	ADC0_PCTNCT25 00000000	ADC0_PCTPCT25 00000000
0xB07000F8	ADC0_PCTNRL26 00000000	ADC0_PCTPRL26 00000000
0xB07000FA	ADC0_PCTNCT26 00000000	ADC0_PCTPCT26 00000000

Table 35. Memory Layout of PERI0_RBUS Registers with Default Values (Continued)

Offset	+1	+0
0xB07000FC	ADC0_PCTNRL27 00000000	ADC0_PCTPRL27 00000000
0xB07000FE	ADC0_PCTNCT27 00000000	ADC0_PCTPCT27 00000000
0xB0700100	ADC0_PCTNRL28 00000000	ADC0_PCTPRL28 00000000
0xB0700102	ADC0_PCTNCT28 00000000	ADC0_PCTPCT28 00000000
0xB0700104	ADC0_PCTNRL29 00000000	ADC0_PCTPRL29 00000000
0xB0700106	ADC0_PCTNCT29 00000000	ADC0_PCTPCT29 00000000
0xB0700108	ADC0_PCTNRL30 00000000	ADC0_PCTPRL30 00000000
0xB070010A	ADC0_PCTNCT30 00000000	ADC0_PCTPCT30 00000000
0xB070010C	ADC0_PCTNRL31 00000000	ADC0_PCTPRL31 00000000
0xB070010E	ADC0_PCTNCT31 00000000	ADC0_PCTPCT31 00000000
0xB0700110	ADC0_PCZF10 00000000 00000000	
0xB0700112	ADC0_PCZF32 00000000 00000000	
0xB0700114	ADC0_PCZFC10 00000000 00000000	
0xB0700116	ADC0_PCZFC32 00000000 00000000	
0xB0700118	ADC0_PCIE10 00000000 00000000	
0xB070011A	ADC0_PCIE32 00000000 00000000	
0xB070011C	ADC0_PCIES10 00000000 00000000	
0xB070011E	ADC0_PCIES32 00000000 00000000	
0xB0700120	ADC0_PCIEC10 00000000 00000000	
0xB0700122	ADC0_PCIEC32 00000000 00000000	
0xB0700124- B0707FFE	reserved XXXXXXXX XXXXXXXX	
0xB0708000	FRT0_TCDT 00000000 00000000	
0xB0708002	FRT0_CPCLRB 11111111 11111111	
0xB0708004	FRT0_CPCLR 11111111 11111111	
0xB0708006	FRT0_TCCS 00000000 00000000	
0xB0708008	FRT0_TSTPTCLK 01000000 00000000	

Table 35. Memory Layout of PERI0_RBUS Registers with Default Values (Continued)

Offset	+1	+0
0xB070800A	FRT0_ETCCS 00000000 00000000	
0xB070800C	FRT0_CIMSZIMS 00000000 00000000	
0xB070800E	reserved XXXXXXXX	FRT0_DMACFG 00000000
0xB0708010- B07083FE	reserved XXXXXXXX XXXXXXXX	
0xB0708400	FRT1_TCDT 00000000 00000000	
0xB0708402	FRT1_CPCLRB 11111111 11111111	
0xB0708404	FRT1_CPCLR 11111111 11111111	
0xB0708406	FRT1_TCCS 00000000 00000000	
0xB0708408	FRT1_TSTPTCLK 01000000 00000000	
0xB070840A	FRT1_ETCCS 00000000 00000000	
0xB070840C	FRT1_CIMSZIMS 00000000 00000000	
0xB070840E	reserved XXXXXXXX	FRT1_DMACFG 00000000
0xB0708410- B07087FE	reserved XXXXXXXX XXXXXXXX	
0xB0708800	FRT2_TCDT 00000000 00000000	
0xB0708802	FRT2_CPCLRB 11111111 11111111	
0xB0708804	FRT2_CPCLR 11111111 11111111	
0xB0708806	FRT2_TCCS 00000000 00000000	
0xB0708808	FRT2_TSTPTCLK 01000000 00000000	
0xB070880A	FRT2_ETCCS 00000000 00000000	
0xB070880C	FRT2_CIMSZIMS 00000000 00000000	
0xB070880E	reserved XXXXXXXX	FRT2_DMACFG 00000000
0xB0708810- B0708BFE	reserved XXXXXXXX XXXXXXXX	
0xB0708C00	FRT3_TCDT 00000000 00000000	
0xB0708C02	FRT3_CPCLRB 11111111 11111111	
0xB0708C04	FRT3_CPCLR 11111111 11111111	
0xB0708C06	FRT3_TCCS 00000000 00000000	

Table 35. Memory Layout of PERI0_RBUS Registers with Default Values (Continued)

Offset	+1	+0
0xB0708C08	FRT3_TSTPTCLK 01000000 00000000	
0xB0708C0A	FRT3_ETCCS 00000000 00000000	
0xB0708C0C	FRT3_CIMSZIMS 00000000 00000000	
0xB0708C0E	reserved XXXXXXXX	FRT3_DMACFG 00000000
0xB0708C10- B07107FE	reserved XXXXXXXX XXXXXXXX	
0xB0710800	ICU2_IPC0 00000000 00000000	
0xB0710802	ICU2_IPC1 00000000 00000000	
0xB0710804	ICU2_ICC01 00000000 00000000	
0xB0710806	ICU2_ICEICS01 00000000 00000000	
0xB0710808	ICU2_DEBUG01 00000000	ICU2_DMACFG01 00000000
0xB071080A- B0710BFE	reserved XXXXXXXX XXXXXXXX	
0xB0710C00	ICU3_IPC0 00000000 00000000	
0xB0710C02	ICU3_IPC1 00000000 00000000	
0xB0710C04	ICU3_ICC01 00000000 00000000	
0xB0710C06	ICU3_ICEICS01 00000000 00000000	
0xB0710C08	ICU3_DEBUG01 00000000	ICU3_DMACFG01 00000000
0xB0710C0A- B0717FFE	reserved XXXXXXXX XXXXXXXX	
0xB0718000	OCU0_OCCP0 00000000 00000000	
0xB0718002	OCU0_OCCP1 00000000 00000000	
0xB0718004	OCU0_OCCPB0 00000000 00000000	
0xB0718006	OCU0_OCCPB1 00000000 00000000	
0xB0718008	OCU0_OCCPBD0 00000000 00000000	
0xB071800A	OCU0_OCCPBD1 00000000 00000000	
0xB071800C	OCU0_OCS01 00000000 00000000	
0xB071800E	OCU0_OCSC01 00000000 00000000	
0xB0718010	OCU0_OCSS01 00000000 00000000	

Table 35. Memory Layout of PERI0_RBUS Registers with Default Values (Continued)

Offset	+1	+0
0xB0718012	reserved XXXXXXXX	OCU0_OSR01 00000000
0xB0718014	reserved XXXXXXXX	OCU0_OSCR01 00000000
0xB0718016	OCU0_EOCS01 00000000 00000000	
0xB0718018	OCU0_EOCSSH01 00000000	reserved XXXXXXXX
0xB071801A	OCU0_EOCSCH01 00000000	reserved XXXXXXXX
0xB071801C	OCU0_DEBUG01 00000000	OCU0_DMACFG01 00000000
0xB071801E	OCU0_OCMCR01 00000000	reserved XXXXXXXX
0xB0718020- B07183FE	reserved XXXXXXXX XXXXXXXX	
0xB0718400	OCU1_OCCP0 00000000 00000000	
0xB0718402	OCU1_OCCP1 00000000 00000000	
0xB0718404	OCU1_OCCPB0 00000000 00000000	
0xB0718406	OCU1_OCCPB1 00000000 00000000	
0xB0718408	OCU1_OCCPBD0 00000000 00000000	
0xB071840A	OCU1_OCCPBD1 00000000 00000000	
0xB071840C	OCU1_OCS01 00000000 00000000	
0xB071840E	OCU1_OCSC01 00000000 00000000	
0xB0718410	OCU1_OCSS01 00000000 00000000	
0xB0718412	reserved XXXXXXXX	OCU1_OSR01 00000000
0xB0718414	reserved XXXXXXXX	OCU1_OSCR01 00000000
0xB0718416	OCU1_EOCS01 00000000 00000000	
0xB0718418	OCU1_EOCSSH01 00000000	reserved XXXXXXXX
0xB071841A	OCU1_EOCSCH01 00000000	reserved XXXXXXXX
0xB071841C	OCU1_DEBUG01 00000000	OCU1_DMACFG01 00000000
0xB071841E	OCU1_OCMCR01 00000000	reserved XXXXXXXX
0xB0718420- B071FFFE	reserved XXXXXXXX XXXXXXXX	
0xB0720000	I2C0_IBCSR 00000000 00000000	

Table 35. Memory Layout of PERI0_RBUS Registers with Default Values (Continued)

Offset	+1	+0
0xB0720002	I2C0_ITBA 00000000 00000000	
0xB0720004	I2C0_ITMK 00XXXX11 11111111	
0xB0720006	I2C0_ISBMA 01111111 00000000	
0xB0720008	reserved XXXXXXXX	I2C0_IODAR 00000000
0xB072000A	reserved XXXXXXXX	I2C0_ICCR 00111111
0xB072000C	I2C0_ICDIDAR 00000000 00000000	
0xB072000E	I2C0_IEICR 00000000 00000000	
0xB0720010	I2C0_DDMACFG 00000000 00000000	
0xB0720012	reserved XXXXXXXX	I2C0_IEIER 00000000
0xB0720014- B0727FFE	reserved XXXXXXXX XXXXXXXX	
0xB0728000	USART0_SCR 00000000	USART0_SMR 00000000
0xB0728002	USART0_SCSR 00000000	USART0_SMSR 00000000
0xB0728004	USART0_SCCR 00000000	reserved XXXXXXXX
0xB0728006	USART0_SSR 00001000	USART0_TDR 00000000
0xB0728008	USART0_SSSR 00000000	USART0_RDR 00000000
0xB072800A	USART0_SSCR 00000000	reserved XXXXXXXX
0xB072800C	USART0_ESCR 00000100	USART0_ECCR 000000XX
0xB072800E	USART0_ESCSR 00000000	USART0_ECCSR 00000000
0xB0728010	USART0_ESCCR 00000000	USART0_ECCCR 00000000
0xB0728012	USART0_EIER 00000000	USART0_ESIR 000010X0
0xB0728014	USART0_EIESR 00000000	USART0_ESISR 00000000
0xB0728016	USART0_EIECR 00000000	USART0_ESICR 00000000
0xB0728018	USART0_EFERH 00000000	USART0_EFERL 00000000
0xB072801A	USART0_TFCR 00000000	USART0_RFCR 00000000
0xB072801C	USART0_TFCR 00000000	USART0_RFCR 00000000

Table 35. Memory Layout of PERI0_RBUS Registers with Default Values (Continued)

Offset	+1	+0
0xB072801E	USART0_TFCCR 00000000	USART0_RFCCR 00000000
0xB0728020	USART0_TFSR 00000000	USART0_RFSR 00000000
0xB0728022	USART0_ESR 00000000	USART0_CSCR 00000000
0xB0728024	reserved XXXXXXXX	USART0_CSCSR 00000000
0xB0728026	USART0_ESCLR 00000000	USART0_CSCCR 00000000
0xB0728028	USART0_BGRLM 00000000	USART0_BGRLL 00000000
0xB072802A	reserved XXXXXXXX	USART0_BGRLH 00000000
0xB072802C	USART0_BGRM 00000000	USART0_BGRL 00000000
0xB072802E	reserved XXXXXXXX	USART0_BGRH 00000000
0xB0728030	USART0_SRXDR 00000000	USART0_STXDR 00000000
0xB0728032	USART0_SRXDSR 00000000	USART0_STXDSR 00000000
0xB0728034	USART0_SRXDRCR 00000000	USART0_STXDRCR 00000000
0xB0728036	read0 00000000	read0 00000000
0xB0728038	reserved XXXXXXXX	read0 00000000
0xB072803A	reserved XXXXXXXX	USART0_FIDR 00000000
0xB072803C	reserved XXXXXXXX	USART0_DEBUG 00000000
0xB072803E- B072FFFE	reserved XXXXXXXX XXXXXXXX	
0xB0730000	reserved XXXXXXXX	SMC0_PWC 00000000
0xB0730002	reserved XXXXXXXX	SMC0_PWCS 00000000
0xB0730004	reserved XXXXXXXX	SMC0_PWCC 00000000
0xB0730006	SMC0_PWC1 000000XX XXXXXXXX	
0xB0730008	SMC0_PWC2 000000XX XXXXXXXX	
0xB073000A	SMC0_PWS 00000000 00000000	
0xB073000C	SMC0_PWSS 00000000 XXXXXXXX	
0xB073000E	reserved XXXXXXXX	SMC0_PTRGDL 00000000

Table 35. Memory Layout of PERI0_RBUS Registers with Default Values (Continued)

Offset	+1	+0
0xB0730010	reserved XXXXXXXX	SMC0_DEBUG 00000000
0xB0730012- B07303FE	reserved XXXXXXXX XXXXXXXX	
0xB0730400	reserved XXXXXXXX	SMC1_PWC 00000000
0xB0730402	reserved XXXXXXXX	SMC1_PWCS 00000000
0xB0730404	reserved XXXXXXXX	SMC1_PWCC 00000000
0xB0730406	SMC1_PWC1 000000XX XXXXXXXX	
0xB0730408	SMC1_PWC2 000000XX XXXXXXXX	
0xB073040A	SMC1_PWS 00000000 00000000	
0xB073040C	SMC1_PWSS 00000000 XXXXXXXX	
0xB073040E	reserved XXXXXXXX	SMC1_PTRGDL 00000000
0xB0730410	reserved XXXXXXXX	SMC1_DEBUG 00000000
0xB0730412- B07307FE	reserved XXXXXXXX XXXXXXXX	
0xB0730800	reserved XXXXXXXX	SMC2_PWC 00000000
0xB0730802	reserved XXXXXXXX	SMC2_PWCS 00000000
0xB0730804	reserved XXXXXXXX	SMC2_PWCC 00000000
0xB0730806	SMC2_PWC1 000000XX XXXXXXXX	
0xB0730808	SMC2_PWC2 000000XX XXXXXXXX	
0xB073080A	SMC2_PWS 00000000 00000000	
0xB073080C	SMC2_PWSS 00000000 XXXXXXXX	
0xB073080E	reserved XXXXXXXX	SMC2_PTRGDL 00000000
0xB0730810	reserved XXXXXXXX	SMC2_DEBUG 00000000
0xB0730812- B0730BFE	reserved XXXXXXXX XXXXXXXX	
0xB0730C00	reserved XXXXXXXX	SMC3_PWC 00000000
0xB0730C02	reserved XXXXXXXX	SMC3_PWCS 00000000
0xB0730C04	reserved XXXXXXXX	SMC3_PWCC 00000000
0xB0730C06	SMC3_PWC1 000000XX XXXXXXXX	

Table 35. Memory Layout of PERI0_RBUS Registers with Default Values (Continued)

Offset	+1	+0
0xB0730C08	SMC3_PWC2 000000XX XXXXXXXX	
0xB0730C0A	SMC3_PWS 00000000 00000000	
0xB0730C0C	SMC3_PWSS 00000000 XXXXXXXX	
0xB0730C0E	reserved XXXXXXXX	SMC3_PTRGDL 00000000
0xB0730C10	reserved XXXXXXXX	SMC3_DEBUG 00000000
0xB0730C12- B0730FFE	reserved XXXXXXXX XXXXXXXX	
0xB0731000	reserved XXXXXXXX	SMC4_PWC 00000000
0xB0731002	reserved XXXXXXXX	SMC4_PWCS 00000000
0xB0731004	reserved XXXXXXXX	SMC4_PWCC 00000000
0xB0731006	SMC4_PWC1 000000XX XXXXXXXX	
0xB0731008	SMC4_PWC2 000000XX XXXXXXXX	
0xB073100A	SMC4_PWS 00000000 00000000	
0xB073100C	SMC4_PWSS 00000000 XXXXXXXX	
0xB073100E	reserved XXXXXXXX	SMC4_PTRGDL 00000000
0xB0731010	reserved XXXXXXXX	SMC4_DEBUG 00000000
0xB0731012- B07313FE	reserved XXXXXXXX XXXXXXXX	
0xB0731400	reserved XXXXXXXX	SMC5_PWC 00000000
0xB0731402	reserved XXXXXXXX	SMC5_PWCS 00000000
0xB0731404	reserved XXXXXXXX	SMC5_PWCC 00000000
0xB0731406	SMC5_PWC1 000000XX XXXXXXXX	
0xB0731408	SMC5_PWC2 000000XX XXXXXXXX	
0xB073140A	SMC5_PWS 00000000 00000000	
0xB073140C	SMC5_PWSS 00000000 XXXXXXXX	
0xB073140E	reserved XXXXXXXX	SMC5_PTRGDL 00000000
0xB0731410	reserved XXXXXXXX	SMC5_DEBUG 00000000
0xB0731412- B07317FE	reserved XXXXXXXX XXXXXXXX	

Table 35. Memory Layout of PERI0_RBUS Registers with Default Values (Continued)

Offset	+1	+0
0xB0731800	SMCTG0_PTRGS 00000000 00000000	
0xB0731802	reserved XXXXXXXX	SMCTG0_PTRG 00000000
0xB0731804- B0737FFE	reserved XXXXXXXX XXXXXXXX	
0xB0738000	PPG0_PCN 00000000 00000000	
0xB0738002	PPG0_SWTRIG 00000000	PPG0_IRQCLR 00000000
0xB0738004	PPG0_CNTEN 00000000	PPG0_OE 00000000
0xB0738006	PPG0_RMPCFG 00000000	PPG0_OPTMSK 00000000
0xB0738008	PPG0_TRIGCLR 00000000	PPG0_STRD 00000000
0xB073800A	PPG0_EPCN1 00000000 00000000	
0xB073800C	PPG0_EPCN2 00000000 00000000	
0xB073800E	PPG0_GCN3 00000000	PPG0_GCN1 00000000
0xB0738010	PPG0_GCN5 00000000	PPG0_GCN4 00000110
0xB0738012	PPG0_PCSR XXXXXXXX XXXXXXXX	
0xB0738014	PPG0_PDUT XXXXXXXX XXXXXXXX	
0xB0738016	PPG0_PTMR 11111111 11111111	
0xB0738018	PPG0_PSDR 00000000 00000000	
0xB073801A	PPG0_PTPC 00000000 00000000	
0xB073801C	PPG0_PEDR 00000000 00000000	
0xB073801E	PPG0_DEBUG 00000000	PPG0_DMPCFG 00000000
0xB0738020- B07383FE	reserved XXXXXXXX XXXXXXXX	
0xB0738400	PPG1_PCN 00000000 00000000	
0xB0738402	PPG1_SWTRIG 00000000	PPG1_IRQCLR 00000000
0xB0738404	PPG1_CNTEN 00000000	PPG1_OE 00000000
0xB0738406	PPG1_RMPCFG 00000000	PPG1_OPTMSK 00000000
0xB0738408	PPG1_TRIGCLR 00000000	PPG1_STRD 00000000
0xB073840A	PPG1_EPCN1 00000000 00000000	

Table 35. Memory Layout of PERI0_RBUS Registers with Default Values (Continued)

Offset	+1	+0
0xB073840C	PPG1_EPCN2 00000000 00000000	
0xB073840E	PPG1_GCEN3 00000000	PPG1_GCEN1 00000000
0xB0738410	PPG1_GCEN5 00000000	PPG1_GCEN4 00000110
0xB0738412	PPG1_PCSR XXXXXXXX XXXXXXXX	
0xB0738414	PPG1_PDUT XXXXXXXX XXXXXXXX	
0xB0738416	PPG1_PTMR 11111111 11111111	
0xB0738418	PPG1_PSDR 00000000 00000000	
0xB073841A	PPG1_PTPC 00000000 00000000	
0xB073841C	PPG1_PEDR 00000000 00000000	
0xB073841E	PPG1_DEBUG 00000000	PPG1_DMACFG 00000000
0xB0738420- B07387FE	reserved XXXXXXXX XXXXXXXX	
0xB0738800	PPG2_PCN 00000000 00000000	
0xB0738802	PPG2_SWTRIG 00000000	PPG2_IRQCLR 00000000
0xB0738804	PPG2_CNEN 00000000	PPG2_OE 00000000
0xB0738806	PPG2_RMPCFG 00000000	PPG2_OPTMSK 00000000
0xB0738808	PPG2_TRIGCLR 00000000	PPG2_STRD 00000000
0xB073880A	PPG2_EPCN1 00000000 00000000	
0xB073880C	PPG2_EPCN2 00000000 00000000	
0xB073880E	PPG2_GCEN3 00000000	PPG2_GCEN1 00000000
0xB0738810	PPG2_GCEN5 00000000	PPG2_GCEN4 00000110
0xB0738812	PPG2_PCSR XXXXXXXX XXXXXXXX	
0xB0738814	PPG2_PDUT XXXXXXXX XXXXXXXX	
0xB0738816	PPG2_PTMR 11111111 11111111	
0xB0738818	PPG2_PSDR 00000000 00000000	
0xB073881A	PPG2_PTPC 00000000 00000000	
0xB073881C	PPG2_PEDR 00000000 00000000	

Table 35. Memory Layout of PERI0_RBUS Registers with Default Values (Continued)

Offset	+1	+0
0xB073881E	PPG2_DEBUG 00000000	PPG2_DMCFG 00000000
0xB0738820- B0738BFE	reserved XXXXXXXX XXXXXXXX	
0xB0738C00	PPG3_PCN 00000000 00000000	
0xB0738C02	PPG3_SWTRIG 00000000	PPG3_IRQCLR 00000000
0xB0738C04	PPG3_CNTEN 00000000	PPG3_OE 00000000
0xB0738C06	PPG3_RMPCFG 00000000	PPG3_OPTMSK 00000000
0xB0738C08	PPG3_TRIGCLR 00000000	PPG3_STRD 00000000
0xB0738C0A	PPG3_EPCN1 00000000 00000000	
0xB0738C0C	PPG3_EPCN2 00000000 00000000	
0xB0738C0E	PPG3_GCN3 00000000	PPG3_GCN1 00000000
0xB0738C10	PPG3_GCN5 00000000	PPG3_GCN4 00000110
0xB0738C12	PPG3_PCSR XXXXXXXX XXXXXXXX	
0xB0738C14	PPG3_PDUT XXXXXXXX XXXXXXXX	
0xB0738C16	PPG3_PTMR 11111111 11111111	
0xB0738C18	PPG3_PSDR 00000000 00000000	
0xB0738C1A	PPG3_PTPC 00000000 00000000	
0xB0738C1C	PPG3_PEDR 00000000 00000000	
0xB0738C1E	PPG3_DEBUG 00000000	PPG3_DMCFG 00000000
0xB0738C20- B0738FFE	reserved XXXXXXXX XXXXXXXX	
0xB0739000	PPG4_PCN 00000000 00000000	
0xB0739002	PPG4_SWTRIG 00000000	PPG4_IRQCLR 00000000
0xB0739004	PPG4_CNTEN 00000000	PPG4_OE 00000000
0xB0739006	PPG4_RMPCFG 00000000	PPG4_OPTMSK 00000000
0xB0739008	PPG4_TRIGCLR 00000000	PPG4_STRD 00000000
0xB073900A	PPG4_EPCN1 00000000 00000000	
0xB073900C	PPG4_EPCN2 00000000 00000000	

Table 35. Memory Layout of PERI0_RBUS Registers with Default Values (Continued)

Offset	+1	+0
0xB073900E	PPG4_GCN3 00000000	PPG4_GCN1 00000000
0xB0739010	PPG4_GCN5 00000000	PPG4_GCN4 00000110
0xB0739012	PPG4_PCSR XXXXXXXX XXXXXXXX	
0xB0739014	PPG4_PDUT XXXXXXXX XXXXXXXX	
0xB0739016	PPG4_PTMR 11111111 11111111	
0xB0739018	PPG4_PSDR 00000000 00000000	
0xB073901A	PPG4_PTPC 00000000 00000000	
0xB073901C	PPG4_PEDR 00000000 00000000	
0xB073901E	PPG4_DEBUG 00000000	PPG4_DMACFG 00000000
0xB0739020- B07393FE	reserved XXXXXXXX XXXXXXXX	
0xB0739400	PPG5_PCN 00000000 00000000	
0xB0739402	PPG5_SWTRIG 00000000	PPG5_IRQCLR 00000000
0xB0739404	PPG5_CNTEN 00000000	PPG5_OE 00000000
0xB0739406	PPG5_RMPCFG 00000000	PPG5_OPTMSK 00000000
0xB0739408	PPG5_TRIGCLR 00000000	PPG5_STRD 00000000
0xB073940A	PPG5_EPCN1 00000000 00000000	
0xB073940C	PPG5_EPCN2 00000000 00000000	
0xB073940E	PPG5_GCN3 00000000	PPG5_GCN1 00000000
0xB0739410	PPG5_GCN5 00000000	PPG5_GCN4 00000110
0xB0739412	PPG5_PCSR XXXXXXXX XXXXXXXX	
0xB0739414	PPG5_PDUT XXXXXXXX XXXXXXXX	
0xB0739416	PPG5_PTMR 11111111 11111111	
0xB0739418	PPG5_PSDR 00000000 00000000	
0xB073941A	PPG5_PTPC 00000000 00000000	
0xB073941C	PPG5_PEDR 00000000 00000000	
0xB073941E	PPG5_DEBUG 00000000	PPG5_DMACFG 00000000

Table 35. Memory Layout of PERI0_RBUS Registers with Default Values (Continued)

Offset	+1	+0
0xB0739420- B07397FE	reserved XXXXXXXX XXXXXXXX	
0xB0739800	PPG6_PCN 00000000 00000000	
0xB0739802	PPG6_SWTRIG 00000000	PPG6_IRQCLR 00000000
0xB0739804	PPG6_CNTEN 00000000	PPG6_OE 00000000
0xB0739806	PPG6_RMPCFG 00000000	PPG6_OPTMSK 00000000
0xB0739808	PPG6_TRIGCLR 00000000	PPG6_STRD 00000000
0xB073980A	PPG6_EPCN1 00000000 00000000	
0xB073980C	PPG6_EPCN2 00000000 00000000	
0xB073980E	PPG6_GCN3 00000000	PPG6_GCN1 00000000
0xB0739810	PPG6_GCN5 00000000	PPG6_GCN4 00000110
0xB0739812	PPG6_PCSR XXXXXXXX XXXXXXXX	
0xB0739814	PPG6_PDUT XXXXXXXX XXXXXXXX	
0xB0739816	PPG6_PTMR 11111111 11111111	
0xB0739818	PPG6_PSDR 00000000 00000000	
0xB073981A	PPG6_PTPC 00000000 00000000	
0xB073981C	PPG6_PEDR 00000000 00000000	
0xB073981E	PPG6_DEBUG 00000000	PPG6_DMACFG 00000000
0xB0739820- B0739BFE	reserved XXXXXXXX XXXXXXXX	
0xB0739C00	PPG7_PCN 00000000 00000000	
0xB0739C02	PPG7_SWTRIG 00000000	PPG7_IRQCLR 00000000
0xB0739C04	PPG7_CNTEN 00000000	PPG7_OE 00000000
0xB0739C06	PPG7_RMPCFG 00000000	PPG7_OPTMSK 00000000
0xB0739C08	PPG7_TRIGCLR 00000000	PPG7_STRD 00000000
0xB0739C0A	PPG7_EPCN1 00000000 00000000	
0xB0739C0C	PPG7_EPCN2 00000000 00000000	
0xB0739C0E	PPG7_GCN3 00000000	PPG7_GCN1 00000000

Table 35. Memory Layout of PERI0_RBUS Registers with Default Values (Continued)

Offset	+1	+0
0xB0739C10	PPG7_GCN5 00000000	PPG7_GCN4 00000110
0xB0739C12	PPG7_PCSR XXXXXXXX XXXXXXXX	
0xB0739C14	PPG7_PDUT XXXXXXXX XXXXXXXX	
0xB0739C16	PPG7_PTMR 11111111 11111111	
0xB0739C18	PPG7_PSDR 00000000 00000000	
0xB0739C1A	PPG7_PTPC 00000000 00000000	
0xB0739C1C	PPG7_PEDR 00000000 00000000	
0xB0739C1E	PPG7_DEBUG 00000000	PPG7_DMACFG 00000000
0xB0739C20- B0739FFE	reserved XXXXXXXX XXXXXXXX	
0xB073A000	PPG8_PCN 00000000 00000000	
0xB073A002	PPG8_SWTRIG 00000000	PPG8_IRQCLR 00000000
0xB073A004	PPG8_CNTEN 00000000	PPG8_OE 00000000
0xB073A006	PPG8_RMPCFG 00000000	PPG8_OPTMSK 00000000
0xB073A008	PPG8_TRIGCLR 00000000	PPG8_STRD 00000000
0xB073A00A	PPG8_EPCN1 00000000 00000000	
0xB073A00C	PPG8_EPCN2 00000000 00000000	
0xB073A00E	PPG8_GCN3 00000000	PPG8_GCN1 00000000
0xB073A010	PPG8_GCN5 00000000	PPG8_GCN4 00000110
0xB073A012	PPG8_PCSR XXXXXXXX XXXXXXXX	
0xB073A014	PPG8_PDUT XXXXXXXX XXXXXXXX	
0xB073A016	PPG8_PTMR 11111111 11111111	
0xB073A018	PPG8_PSDR 00000000 00000000	
0xB073A01A	PPG8_PTPC 00000000 00000000	
0xB073A01C	PPG8_PEDR 00000000 00000000	
0xB073A01E	PPG8_DEBUG 00000000	PPG8_DMACFG 00000000
0xB073A020- B073A3FE	reserved XXXXXXXX XXXXXXXX	

Table 35. Memory Layout of PERI0_RBUS Registers with Default Values (Continued)

Offset	+1	+0
0xB073A400	PPG9_PCN 00000000 00000000	
0xB073A402	PPG9_SWTRIG 00000000	PPG9_IRQCLR 00000000
0xB073A404	PPG9_CNTEN 00000000	PPG9_OE 00000000
0xB073A406	PPG9_RMPCFG 00000000	PPG9_OPTMSK 00000000
0xB073A408	PPG9_TRIGCLR 00000000	PPG9_STRD 00000000
0xB073A40A	PPG9_EPCN1 00000000 00000000	
0xB073A40C	PPG9_EPCN2 00000000 00000000	
0xB073A40E	PPG9_GCN3 00000000	PPG9_GCN1 00000000
0xB073A410	PPG9_GCN5 00000000	PPG9_GCN4 00000110
0xB073A412	PPG9_PCSR XXXXXXXX XXXXXXXX	
0xB073A414	PPG9_PDUT XXXXXXXX XXXXXXXX	
0xB073A416	PPG9_PTMR 11111111 11111111	
0xB073A418	PPG9_PSDR 00000000 00000000	
0xB073A41A	PPG9_PTPC 00000000 00000000	
0xB073A41C	PPG9_PEDR 00000000 00000000	
0xB073A41E	PPG9_DEBUG 00000000	PPG9_DMACFG 00000000
0xB073A420- B073A7FE	reserved XXXXXXXX XXXXXXXX	
0xB073A800	PPG10_PCN 00000000 00000000	
0xB073A802	PPG10_SWTRIG 00000000	PPG10_IRQCLR 00000000
0xB073A804	PPG10_CNTEN 00000000	PPG10_OE 00000000
0xB073A806	PPG10_RMPCFG 00000000	PPG10_OPTMSK 00000000
0xB073A808	PPG10_TRIGCLR 00000000	PPG10_STRD 00000000
0xB073A80A	PPG10_EPCN1 00000000 00000000	
0xB073A80C	PPG10_EPCN2 00000000 00000000	
0xB073A80E	PPG10_GCN3 00000000	PPG10_GCN1 00000000
0xB073A810	PPG10_GCN5 00000000	PPG10_GCN4 00000110

Table 35. Memory Layout of PERI0_RBUS Registers with Default Values (Continued)

Offset	+1	+0
0xB073A812	PPG10_PCSR XXXXXXXX XXXXXXXX	
0xB073A814	PPG10_PDUT XXXXXXXX XXXXXXXX	
0xB073A816	PPG10_PTMR 11111111 11111111	
0xB073A818	PPG10_PSDR 00000000 00000000	
0xB073A81A	PPG10_PTPC 00000000 00000000	
0xB073A81C	PPG10_PEDR 00000000 00000000	
0xB073A81E	PPG10_DEBUG 00000000	PPG10_DMACFG 00000000
0xB073A820- B073ABFE	reserved XXXXXXXX XXXXXXXX	
0xB073AC00	PPG11_PCN 00000000 00000000	
0xB073AC02	PPG11_SWTRIG 00000000	PPG11_IRQCLR 00000000
0xB073AC04	PPG11_CNTEN 00000000	PPG11_OE 00000000
0xB073AC06	PPG11_RMPCFG 00000000	PPG11_OPTMSK 00000000
0xB073AC08	PPG11_TRIGCLR 00000000	PPG11_STRD 00000000
0xB073AC0A	PPG11_EPCN1 00000000 00000000	
0xB073AC0C	PPG11_EPCN2 00000000 00000000	
0xB073AC0E	PPG11_GCN3 00000000	PPG11_GCN1 00000000
0xB073AC10	PPG11_GCN5 00000000	PPG11_GCN4 00000110
0xB073AC12	PPG11_PCSR XXXXXXXX XXXXXXXX	
0xB073AC14	PPG11_PDUT XXXXXXXX XXXXXXXX	
0xB073AC16	PPG11_PTMR 11111111 11111111	
0xB073AC18	PPG11_PSDR 00000000 00000000	
0xB073AC1A	PPG11_PTPC 00000000 00000000	
0xB073AC1C	PPG11_PEDR 00000000 00000000	
0xB073AC1E	PPG11_DEBUG 00000000	PPG11_DMACFG 00000000
0xB073AC20- B073AFFE	reserved XXXXXXXX XXXXXXXX	
0xB073B000	PPG12_PCN 00000000 00000000	

Table 35. Memory Layout of PERI0_RBUS Registers with Default Values (Continued)

Offset	+1	+0
0xB073B002	PPG12_SWTRIG 00000000	PPG12_IRQCLR 00000000
0xB073B004	PPG12_CNTEN 00000000	PPG12_OE 00000000
0xB073B006	PPG12_RMPCFG 00000000	PPG12_OPTMSK 00000000
0xB073B008	PPG12_TRIGCLR 00000000	PPG12_STRD 00000000
0xB073B00A	PPG12_EPCN1 00000000 00000000	
0xB073B00C	PPG12_EPCN2 00000000 00000000	
0xB073B00E	PPG12_GCN3 00000000	PPG12_GCN1 00000000
0xB073B010	PPG12_GCN5 00000000	PPG12_GCN4 00000110
0xB073B012	PPG12_PCSR XXXXXXXX XXXXXXXX	
0xB073B014	PPG12_PDUT XXXXXXXX XXXXXXXX	
0xB073B016	PPG12_PTMR 11111111 11111111	
0xB073B018	PPG12_PSDR 00000000 00000000	
0xB073B01A	PPG12_PTPC 00000000 00000000	
0xB073B01C	PPG12_PEDR 00000000 00000000	
0xB073B01E	PPG12_DEBUG 00000000	PPG12_DMACFG 00000000
0xB073B020- B073B3FE	reserved XXXXXXXX XXXXXXXX	
0xB073B400	PPG13_PCN 00000000 00000000	
0xB073B402	PPG13_SWTRIG 00000000	PPG13_IRQCLR 00000000
0xB073B404	PPG13_CNTEN 00000000	PPG13_OE 00000000
0xB073B406	PPG13_RMPCFG 00000000	PPG13_OPTMSK 00000000
0xB073B408	PPG13_TRIGCLR 00000000	PPG13_STRD 00000000
0xB073B40A	PPG13_EPCN1 00000000 00000000	
0xB073B40C	PPG13_EPCN2 00000000 00000000	
0xB073B40E	PPG13_GCN3 00000000	PPG13_GCN1 00000000
0xB073B410	PPG13_GCN5 00000000	PPG13_GCN4 00000110
0xB073B412	PPG13_PCSR XXXXXXXX XXXXXXXX	

Table 35. Memory Layout of PERI0_RBUS Registers with Default Values (Continued)

Offset	+1	+0
0xB073B414	PPG13_PDUT XXXXXXXX XXXXXXXX	
0xB073B416	PPG13_PTMR 11111111 11111111	
0xB073B418	PPG13_PSDR 00000000 00000000	
0xB073B41A	PPG13_PTPC 00000000 00000000	
0xB073B41C	PPG13_PEDR 00000000 00000000	
0xB073B41E	PPG13_DEBUG 00000000	PPG13_DMACFG 00000000
0xB073B420- B073B7FE	reserved XXXXXXXX XXXXXXXX	
0xB073B800	PPG14_PCN 00000000 00000000	
0xB073B802	PPG14_SWTRIG 00000000	PPG14_IRQCLR 00000000
0xB073B804	PPG14_CNTEN 00000000	PPG14_OE 00000000
0xB073B806	PPG14_RMPCFG 00000000	PPG14_OPTMSK 00000000
0xB073B808	PPG14_TRIGCLR 00000000	PPG14_STRD 00000000
0xB073B80A	PPG14_EPCN1 00000000 00000000	
0xB073B80C	PPG14_EPCN2 00000000 00000000	
0xB073B80E	PPG14_GCN3 00000000	PPG14_GCN1 00000000
0xB073B810	PPG14_GCN5 00000000	PPG14_GCN4 00000110
0xB073B812	PPG14_PCSR XXXXXXXX XXXXXXXX	
0xB073B814	PPG14_PDUT XXXXXXXX XXXXXXXX	
0xB073B816	PPG14_PTMR 11111111 11111111	
0xB073B818	PPG14_PSDR 00000000 00000000	
0xB073B81A	PPG14_PTPC 00000000 00000000	
0xB073B81C	PPG14_PEDR 00000000 00000000	
0xB073B81E	PPG14_DEBUG 00000000	PPG14_DMACFG 00000000
0xB073B820- B073BBFE	reserved XXXXXXXX XXXXXXXX	
0xB073BC00	PPG15_PCN 00000000 00000000	
0xB073BC02	PPG15_SWTRIG 00000000	PPG15_IRQCLR 00000000

Table 35. Memory Layout of PERI0_RBUS Registers with Default Values (Continued)

Offset	+1	+0
0xB073BC04	PPG15_CNTEN 00000000	PPG15_OE 00000000
0xB073BC06	PPG15_RMPCFG 00000000	PPG15_OPTMSK 00000000
0xB073BC08	PPG15_TRIGCLR 00000000	PPG15_STRD 00000000
0xB073BC0A	PPG15_EPCN1 00000000 00000000	
0xB073BC0C	PPG15_EPCN2 00000000 00000000	
0xB073BC0E	PPG15_GCN3 00000000	PPG15_GCN1 00000000
0xB073BC10	PPG15_GCN5 00000000	PPG15_GCN4 00000110
0xB073BC12	PPG15_PCSR XXXXXXXX XXXXXXXX	
0xB073BC14	PPG15_PDUT XXXXXXXX XXXXXXXX	
0xB073BC16	PPG15_PTMR 11111111 11111111	
0xB073BC18	PPG15_PSDR 00000000 00000000	
0xB073BC1A	PPG15_PTPC 00000000 00000000	
0xB073BC1C	PPG15_PEDR 00000000 00000000	
0xB073BC1E	PPG15_DEBUG 00000000	PPG15_DMACFG 00000000
0xB073BC20- B0747FFE	reserved XXXXXXXX XXXXXXXX	
0xB0748000	reserved XXXXXXXX	PPGGRP0_GCTRL 00000000
0xB0748002- B07483FE	reserved XXXXXXXX XXXXXXXX	
0xB0748400	reserved XXXXXXXX	PPGGRP1_GCTRL 00000000
0xB0748402- B07487FE	reserved XXXXXXXX XXXXXXXX	
0xB0748800	reserved XXXXXXXX	PPGGRP2_GCTRL 00000000
0xB0748802- B0748BFE	reserved XXXXXXXX XXXXXXXX	
0xB0748C00	reserved XXXXXXXX	PPGGRP3_GCTRL 00000000
0xB0748C02- B074BFFE	reserved XXXXXXXX XXXXXXXX	
0xB074C000	reserved XXXXXXXX	PPGGLC0_GCNR 00000000
0xB074C002- B07E7FFE	reserved XXXXXXXX XXXXXXXX	
0xB07E8000	PPC_PCFGR000 0XX00000 00000000	

Table 35. Memory Layout of PERI0_RBUS Registers with Default Values (Continued)

Offset	+1	+0
0xB07E8002		PPC_PCFGR001 0XX00000 00000000
0xB07E8004		PPC_PCFGR002 0XX00000 00000000
0xB07E8006		PPC_PCFGR003 0XX00000 00000000
0xB07E8008		PPC_PCFGR004 0XX00000 00000000
0xB07E800A		PPC_PCFGR005 0XX00000 00000000
0xB07E800C		PPC_PCFGR006 0XX00000 00000000
0xB07E800E		PPC_PCFGR007 0XX00000 00000000
0xB07E8010		PPC_PCFGR008 0XX00000 00000000
0xB07E8012		PPC_PCFGR009 0XX00000 00000000
0xB07E8014		PPC_PCFGR010 0XX00000 00000000
0xB07E8016		PPC_PCFGR011 0XX00000 00000000
0xB07E8018		PPC_PCFGR012 0XX00000 00000000
0xB07E801A		PPC_PCFGR013 0XX00000 00000000
0xB07E801C		PPC_PCFGR014 0XX00000 00000000
0xB07E801E		PPC_PCFGR015 0XX00000 00000000
0xB07E8020		PPC_PCFGR016 0XX00000 00000000
0xB07E8022		PPC_PCFGR017 0XX00000 00000000
0xB07E8024		PPC_PCFGR018 0XX00000 00000000
0xB07E8026		PPC_PCFGR019 0XX00000 00000000
0xB07E8028		PPC_PCFGR020 0XX00000 00000000
0xB07E802A		PPC_PCFGR021 0XX00000 00000000
0xB07E802C		PPC_PCFGR022 0XX00000 00000000
0xB07E802E		PPC_PCFGR023 0XX00000 00000000
0xB07E8030		PPC_PCFGR024 0XX00000 00000000
0xB07E8032		PPC_PCFGR025 0XX00000 00000000
0xB07E8034		PPC_PCFGR026 0XX00000 00000000

Table 35. Memory Layout of PERI0_RBUS Registers with Default Values (Continued)

Offset	+1	+0
0xB07E8036		PPC_PCFGR027 0XX00000 00000000
0xB07E8038		PPC_PCFGR028 0XX00000 00000000
0xB07E803A		PPC_PCFGR029 0XX00000 00000000
0xB07E803C		PPC_PCFGR030 0XX00000 00000000
0xB07E803E		PPC_PCFGR031 0XX00000 00000000
0xB07E8040		PPC_PCFGR032 0XX00000 00000000
0xB07E8042		PPC_PCFGR033 0XX00000 00000000
0xB07E8044		PPC_PCFGR034 0XX00000 00000000
0xB07E8046		PPC_PCFGR035 0XX00000 00000000
0xB07E8048		PPC_PCFGR036 0XX00000 00000000
0xB07E804A		PPC_PCFGR037 0XX00000 00000000
0xB07E804C		PPC_PCFGR038 0XX00000 00000000
0xB07E804E		PPC_PCFGR039 0XX00000 00000000
0xB07E8050		PPC_PCFGR040 0XX00000 00000000
0xB07E8052		PPC_PCFGR041 0XX00000 00000000
0xB07E8054		PPC_PCFGR042 0XX00000 00000000
0xB07E8056		PPC_PCFGR043 0XX00000 00000000
0xB07E8058		PPC_PCFGR044 0XX00000 00000000
0xB07E805A		PPC_PCFGR045 0XX00000 00000000
0xB07E805C		PPC_PCFGR046 0XX00000 00000000
0xB07E805E		PPC_PCFGR047 0XX00000 00000000
0xB07E8060		PPC_PCFGR048 0XX00000 00000000
0xB07E8062		PPC_PCFGR049 0XX00000 00000000
0xB07E8064		PPC_PCFGR050 0XX00000 00000000
0xB07E8066		PPC_PCFGR051 0XX00000 00000000
0xB07E8068		PPC_PCFGR052 0XX00000 00000000

Table 35. Memory Layout of PERI0_RBUS Registers with Default Values (Continued)

Offset	+1	+0
0xB07E806A		PPC_PCFGR053 0XX00000 00000000
0xB07E806C		PPC_PCFGR054 0XX00000 00000000
0xB07E806E		PPC_PCFGR055 0XX00000 00000000
0xB07E8070		PPC_PCFGR056 0XX00000 00000000
0xB07E8072		PPC_PCFGR057 0XX00000 00000000
0xB07E8074		PPC_PCFGR058 0XX00000 00000000
0xB07E8076		PPC_PCFGR059 0XX00000 00000000
0xB07E8078		PPC_PCFGR060 0XX00000 00000000
0xB07E807A		PPC_PCFGR061 0XX00000 00000000
0xB07E807C		PPC_PCFGR062 0XX00000 00000000
0xB07E807E		PPC_PCFGR063 0XX00000 00000000
0xB07E8080		PPC_PCFGR100 0XX00000 00000000
0xB07E8082		PPC_PCFGR101 0XX00000 00000000
0xB07E8084		PPC_PCFGR102 0XX00000 00000000
0xB07E8086		PPC_PCFGR103 0XX00000 00000000
0xB07E8088		PPC_PCFGR104 0XX00000 00000000
0xB07E808A		PPC_PCFGR105 0XX00000 00000000
0xB07E808C		PPC_PCFGR106 0XX00000 00000000
0xB07E808E		PPC_PCFGR107 0XX00000 00000000
0xB07E8090		PPC_PCFGR108 0XX00000 00000000
0xB07E8092		PPC_PCFGR109 0XX00000 00000000
0xB07E8094		PPC_PCFGR110 0XX00000 00000000
0xB07E8096		PPC_PCFGR111 0XX00000 00000000
0xB07E8098		PPC_PCFGR112 0XX00000 00000000
0xB07E809A		PPC_PCFGR113 0XX00000 00000000
0xB07E809C		PPC_PCFGR114 0XX00000 00000000

Table 35. Memory Layout of PERI0_RBUS Registers with Default Values (Continued)

Offset	+1	+0
0xB07E809E		PPC_PCFGR115 0XX00000 00000000
0xB07E80A0		PPC_PCFGR116 0XX00000 00000000
0xB07E80A2		PPC_PCFGR117 0XX00000 00000000
0xB07E80A4		PPC_PCFGR118 0XX00000 00000000
0xB07E80A6		PPC_PCFGR119 0XX00000 00000000
0xB07E80A8		PPC_PCFGR120 0XX00000 00000000
0xB07E80AA		PPC_PCFGR121 0XX00000 00000000
0xB07E80AC		PPC_PCFGR122 0XX00000 00000000
0xB07E80AE		PPC_PCFGR123 0XX00000 00000000
0xB07E80B0		PPC_PCFGR124 0XX00000 00000000
0xB07E80B2		PPC_PCFGR125 0XX00000 00000000
0xB07E80B4		PPC_PCFGR126 0XX00000 00000000
0xB07E80B6		PPC_PCFGR127 0XX00000 00000000
0xB07E80B8		PPC_PCFGR128 0XX00000 00000000
0xB07E80BA		PPC_PCFGR129 0XX00000 00000000
0xB07E80BC		PPC_PCFGR130 0XX00000 00000000
0xB07E80BE		PPC_PCFGR131 0XX00000 00000000
0xB07E80C0		PPC_PCFGR132 0XX00000 00000000
0xB07E80C2		PPC_PCFGR133 0XX00000 00000000
0xB07E80C4		PPC_PCFGR134 0XX00000 00000000
0xB07E80C6		PPC_PCFGR135 0XX00000 00000000
0xB07E80C8		PPC_PCFGR136 0XX00000 00000000
0xB07E80CA		PPC_PCFGR137 0XX00000 00000000
0xB07E80CC		PPC_PCFGR138 0XX00000 00000000
0xB07E80CE		PPC_PCFGR139 0XX00000 00000000
0xB07E80D0		PPC_PCFGR140 0XX00000 00000000

Table 35. Memory Layout of PERI0_RBUS Registers with Default Values (Continued)

Offset	+1	+0
0xB07E80D2		PPC_PCFGR141 0XX00000 00000000
0xB07E80D4		PPC_PCFGR142 0XX00000 00000000
0xB07E80D6		PPC_PCFGR143 0XX00000 00000000
0xB07E80D8		PPC_PCFGR144 0XX00000 00000000
0xB07E80DA		PPC_PCFGR145 0XX00000 00000000
0xB07E80DC		PPC_PCFGR146 0XX00000 00000000
0xB07E80DE		PPC_PCFGR147 0XX00000 00000000
0xB07E80E0		PPC_PCFGR148 0XX00000 00000000
0xB07E80E2		PPC_PCFGR149 0XX00000 00000000
0xB07E80E4		PPC_PCFGR150 0XX00000 00000000
0xB07E80E6		PPC_PCFGR151 0XX00000 00000000
0xB07E80E8		PPC_PCFGR152 0XX00000 00000000
0xB07E80EA		PPC_PCFGR153 0XX00000 00000000
0xB07E80EC		PPC_PCFGR154 0XX00000 00000000
0xB07E80EE		PPC_PCFGR155 0XX00000 00000000
0xB07E80F0		PPC_PCFGR156 0XX00000 00000000
0xB07E80F2		PPC_PCFGR157 0XX00000 00000000
0xB07E80F4		PPC_PCFGR158 0XX00000 00000000
0xB07E80F6		PPC_PCFGR159 0XX00000 00000000
0xB07E80F8		PPC_PCFGR160 0XX00000 00000000
0xB07E80FA		PPC_PCFGR161 0XX00000 00000000
0xB07E80FC		PPC_PCFGR162 0XX00000 00000000
0xB07E80FE		PPC_PCFGR163 0XX00000 00000000
0xB07E8100		PPC_PCFGR200 0XX00000 00000000
0xB07E8102		PPC_PCFGR201 0XX00000 00000000
0xB07E8104		PPC_PCFGR202 0XX00000 00000000

Table 35. Memory Layout of PERI0_RBUS Registers with Default Values (Continued)

Offset	+1	+0
0xB07E8106		PPC_PCFGR203 0XX00000 00000000
0xB07E8108		PPC_PCFGR204 0XX00000 00000000
0xB07E810A		PPC_PCFGR205 0XX00000 00000000
0xB07E810C		PPC_PCFGR206 0XX00000 00000000
0xB07E810E		PPC_PCFGR207 0XX00000 00000000
0xB07E8110		PPC_PCFGR208 0XX00000 00000000
0xB07E8112		PPC_PCFGR209 0XX00000 00000000
0xB07E8114		PPC_PCFGR210 0XX00000 00000000
0xB07E8116		PPC_PCFGR211 0XX00000 00000000
0xB07E8118		PPC_PCFGR212 0XX00000 00000000
0xB07E811A		PPC_PCFGR213 0XX00000 00000000
0xB07E811C		PPC_PCFGR214 0XX00000 00000000
0xB07E811E		PPC_PCFGR215 0XX00000 00000000
0xB07E8120		PPC_PCFGR216 0XX00000 00000000
0xB07E8122		PPC_PCFGR217 0XX00000 00000000
0xB07E8124		PPC_PCFGR218 0XX00000 00000000
0xB07E8126		PPC_PCFGR219 0XX00000 00000000
0xB07E8128		PPC_PCFGR220 0XX00000 00000000
0xB07E812A		PPC_PCFGR221 0XX00000 00000000
0xB07E812C		PPC_PCFGR222 0XX00000 00000000
0xB07E812E		PPC_PCFGR223 0XX00000 00000000
0xB07E8130		PPC_PCFGR224 0XX00000 00000000
0xB07E8132		PPC_PCFGR225 0XX00000 00000000
0xB07E8134		PPC_PCFGR226 0XX00000 00000000
0xB07E8136		PPC_PCFGR227 0XX00000 00000000
0xB07E8138		PPC_PCFGR228 0XX00000 00000000

Table 35. Memory Layout of PERI0_RBUS Registers with Default Values (Continued)

Offset	+1	+0
0xB07E813A		PPC_PCFGR229 0XX00000 00000000
0xB07E813C		PPC_PCFGR230 0XX00000 00000000
0xB07E813E		PPC_PCFGR231 0XX00000 00000000
0xB07E8140		PPC_PCFGR232 0XX00000 00000000
0xB07E8142		PPC_PCFGR233 0XX00000 00000000
0xB07E8144		PPC_PCFGR234 0XX00000 00000000
0xB07E8146		PPC_PCFGR235 0XX00000 00000000
0xB07E8148		PPC_PCFGR236 0XX00000 00000000
0xB07E814A		PPC_PCFGR237 0XX00000 00000000
0xB07E814C		PPC_PCFGR238 0XX00000 00000000
0xB07E814E		PPC_PCFGR239 0XX00000 00000000
0xB07E8150		PPC_PCFGR240 0XX00000 00000000
0xB07E8152		PPC_PCFGR241 0XX00000 00000000
0xB07E8154		PPC_PCFGR242 0XX00000 00000000
0xB07E8156		PPC_PCFGR243 0XX00000 00000000
0xB07E8158		PPC_PCFGR244 0XX00000 00000000
0xB07E815A		PPC_PCFGR245 0XX00000 00000000
0xB07E815C		PPC_PCFGR246 0XX00000 00000000
0xB07E815E		PPC_PCFGR247 0XX00000 00000000
0xB07E8160		PPC_PCFGR248 0XX00000 00000000
0xB07E8162		PPC_PCFGR249 0XX00000 00000000
0xB07E8164		PPC_PCFGR250 0XX00000 00000000
0xB07E8166		PPC_PCFGR251 0XX00000 00000000
0xB07E8168		PPC_PCFGR252 0XX00000 00000000
0xB07E816A		PPC_PCFGR253 0XX00000 00000000
0xB07E816C		PPC_PCFGR254 0XX00000 00000000

Table 35. Memory Layout of PERI0_RBUS Registers with Default Values (Continued)

Offset	+1	+0
0xB07E816E		PPC_PCFGR255 0XX00000 00000000
0xB07E8170		PPC_PCFGR256 0XX00000 00000000
0xB07E8172		PPC_PCFGR257 0XX00000 00000000
0xB07E8174		PPC_PCFGR258 0XX00000 00000000
0xB07E8176		PPC_PCFGR259 0XX00000 00000000
0xB07E8178		PPC_PCFGR260 0XX00000 00000000
0xB07E817A		PPC_PCFGR261 0XX00000 00000000
0xB07E817C		PPC_PCFGR262 0XX00000 00000000
0xB07E817E		PPC_PCFGR263 0XX00000 00000000
0xB07E8180		PPC_PCFGR300 0XX00000 00000000
0xB07E8182		PPC_PCFGR301 0XX00000 00000000
0xB07E8184		PPC_PCFGR302 0XX00000 00000000
0xB07E8186		PPC_PCFGR303 0XX00000 00000000
0xB07E8188		PPC_PCFGR304 0XX00000 00000000
0xB07E818A		PPC_PCFGR305 0XX00000 00000000
0xB07E818C		PPC_PCFGR306 0XX00000 00000000
0xB07E818E		PPC_PCFGR307 0XX00000 00000000
0xB07E8190		PPC_PCFGR308 0XX00000 00000000
0xB07E8192		PPC_PCFGR309 0XX00000 00000000
0xB07E8194		PPC_PCFGR310 0XX00000 00000000
0xB07E8196		PPC_PCFGR311 0XX00000 00000000
0xB07E8198		PPC_PCFGR312 0XX00000 00000000
0xB07E819A		PPC_PCFGR313 0XX00000 00000000
0xB07E819C		PPC_PCFGR314 0XX00000 00000000
0xB07E819E		PPC_PCFGR315 0XX00000 00000000
0xB07E81A0		PPC_PCFGR316 0XX00000 00000000

Table 35. Memory Layout of PERI0_RBUS Registers with Default Values (Continued)

Offset	+1	+0
0xB07E81A2		PPC_PCFGR317 0XX00000 00000000
0xB07E81A4		PPC_PCFGR318 0XX00000 00000000
0xB07E81A6		PPC_PCFGR319 0XX00000 00000000
0xB07E81A8		PPC_PCFGR320 0XX00000 00000000
0xB07E81AA		PPC_PCFGR321 0XX00000 00000000
0xB07E81AC		PPC_PCFGR322 0XX00000 00000000
0xB07E81AE		PPC_PCFGR323 0XX00000 00000000
0xB07E81B0		PPC_PCFGR324 0XX00000 00000000
0xB07E81B2		PPC_PCFGR325 0XX00000 00000000
0xB07E81B4		PPC_PCFGR326 0XX00000 00000000
0xB07E81B6		PPC_PCFGR327 0XX00000 00000000
0xB07E81B8		PPC_PCFGR328 0XX00000 00000000
0xB07E81BA		PPC_PCFGR329 0XX00000 00000000
0xB07E81BC		PPC_PCFGR330 0XX00000 00000000
0xB07E81BE		PPC_PCFGR331 0XX00000 00000000
0xB07E81C0		PPC_PCFGR332 0XX00000 00000000
0xB07E81C2		PPC_PCFGR333 0XX00000 00000000
0xB07E81C4		PPC_PCFGR334 0XX00000 00000000
0xB07E81C6		PPC_PCFGR335 0XX00000 00000000
0xB07E81C8		PPC_PCFGR336 0XX00000 00000000
0xB07E81CA		PPC_PCFGR337 0XX00000 00000000
0xB07E81CC		PPC_PCFGR338 0XX00000 00000000
0xB07E81CE		PPC_PCFGR339 0XX00000 00000000
0xB07E81D0		PPC_PCFGR340 0XX00000 00000000
0xB07E81D2		PPC_PCFGR341 0XX00000 00000000
0xB07E81D4		PPC_PCFGR342 0XX00000 00000000

Table 35. Memory Layout of PERI0_RBUS Registers with Default Values (Continued)

Offset	+1	+0
0xB07E81D6		PPC_PCFGR343 0XX00000 00000000
0xB07E81D8		PPC_PCFGR344 0XX00000 00000000
0xB07E81DA		PPC_PCFGR345 0XX00000 00000000
0xB07E81DC		PPC_PCFGR346 0XX00000 00000000
0xB07E81DE		PPC_PCFGR347 0XX00000 00000000
0xB07E81E0		PPC_PCFGR348 0XX00000 00000000
0xB07E81E2		PPC_PCFGR349 0XX00000 00000000
0xB07E81E4		PPC_PCFGR350 0XX00000 00000000
0xB07E81E6		PPC_PCFGR351 0XX00000 00000000
0xB07E81E8		PPC_PCFGR352 0XX00000 00000000
0xB07E81EA		PPC_PCFGR353 0XX00000 00000000
0xB07E81EC		PPC_PCFGR354 0XX00000 00000000
0xB07E81EE		PPC_PCFGR355 0XX00000 00000000
0xB07E81F0		PPC_PCFGR356 0XX00000 00000000
0xB07E81F2		PPC_PCFGR357 0XX00000 00000000
0xB07E81F4		PPC_PCFGR358 0XX00000 00000000
0xB07E81F6		PPC_PCFGR359 0XX00000 00000000
0xB07E81F8		PPC_PCFGR360 0XX00000 00000000
0xB07E81FA		PPC_PCFGR361 0XX00000 00000000
0xB07E81FC		PPC_PCFGR362 0XX00000 00000000
0xB07E81FE		PPC_PCFGR363 0XX00000 00000000
0xB07E8200- B07EFFFF		reserved XXXXXXXX XXXXXXXX
0xB07F0000		BECU0_CTRL 00000000 00000000
0xB07F0002		BECU0_CTRH 00000000 00000000
0xB07F0004		BECU0_ADDRL 00000000 00000000
0xB07F0006		BECU0_ADDRH 00000000 00000000

Table 35. Memory Layout of PERI0_RBUS Registers with Default Values (Continued)

Offset	+1	+0
0xB07F0008		BECU0_DATALL 00000000 00000000
0xB07F000A		BECU0_DATA LH 00000000 00000000
0xB07F000C		BECU0_DATA HL 00000000 00000000
0xB07F000E		BECU0_DATA HH 00000000 00000000
0xB07F0010		BECU0_MASTERID 00000000 00000000
0xB07F0012		BECU0_MIDL XXXXXXXX XXXXXXXX
0xB07F0014		BECU0_MIDH XXXXXXXX XXXXXXXX
0xB07F0016		reserved 00000000 00000000
0xB07F0018		BECU0_NMIEN XXXXXXXX 00000001
0xB07F001A- B07F7FFE		reserved XXXXXXXX XXXXXXXX
0xB07F8000		RICFG0_ADC0AN26 00000000 XXXXXXXX
0xB07F8002		RICFG0_ADC0AN27 00000000 XXXXXXXX
0xB07F8004		RICFG0_ADC0AN28 00000000 XXXXXXXX
0xB07F8006		RICFG0_ADC0AN29 00000000 XXXXXXXX
0xB07F8008		RICFG0_ADC0AN30 00000000 XXXXXXXX
0xB07F800A		RICFG0_ADC0AN31 00000000 XXXXXXXX
0xB07F800C		RICFG0_ADC0EDGI 00000000 00000000
0xB07F800E		RICFG0_ADC0EDGI0CU0 XXXXXXXX 00000000
0xB07F8010- B07F8014		reserved XXXXXXXX XXXXXXXX
0xB07F8016		RICFG0_ADC0EDGI0CU4 XXXXXXXX 00000000
0xB07F8018- B07F801C		reserved XXXXXXXX XXXXXXXX
0xB07F801E		RICFG0_ADC0TIMI XXXXXXXX 00000000
0xB07F8020		RICFG0_ADC0TIMIRLT XXXXXXXX 00000000
0xB07F8022- B07F803C		reserved XXXXXXXX XXXXXXXX
0xB07F803E		RICFG0_ADC0ZPDEN XXXXXXXX 00000000
0xB07F8040- B07F83FE		reserved XXXXXXXX 00000000

Table 35. Memory Layout of PERI0_RBUS Registers with Default Values (Continued)

Offset	+1	+0
0xB07F8400		RICFG0_FRT0TEXT 00000000 00000000
0xB07F8402- B07F841E		reserved XXXXXXXX 00000000
0xB07F8420		RICFG0_FRT1TEXT 00000000 00000000
0xB07F8422- B07F843E		reserved XXXXXXXX 00000000
0xB07F8440		RICFG0_FRT2TEXT 00000000 00000000
0xB07F8442- B07F845E		reserved XXXXXXXX 00000000
0xB07F8460		RICFG0_FRT3TEXT 00000000 00000000
0xB07F8462- B07F883E		reserved XXXXXXXX 00000000
0xB07F8840		RICFG0_ICU2IN0 00000000 XXXXXXXX
0xB07F8842		RICFG0_ICU2IN1 00000000 XXXXXXXX
0xB07F8844		RICFG0_ICU2FRTSEL XXXXXXXX 00000000
0xB07F8846- B07F885E		reserved XXXXXXXX 00000000
0xB07F8860		RICFG0_ICU3IN0 00000000 XXXXXXXX
0xB07F8862		RICFG0_ICU3IN1 00000000 XXXXXXXX
0xB07F8864		RICFG0_ICU3FRTSEL XXXXXXXX 00000000
0xB07F8866- B07F8BFE		reserved XXXXXXXX 00000000
0xB07F8C00		RICFG0_OCU0OTD0GATE XXXXXXXX 00000000
0xB07F8C02		RICFG0_OCU0OTD0GM XXXXXXXX 00000000
0xB07F8C04		RICFG0_OCU0OTD1GATE XXXXXXXX 00000000
0xB07F8C06		RICFG0_OCU0OTD1GM XXXXXXXX 00000000
0xB07F8C08- B07F8C1E		reserved XXXXXXXX 00000000
0xB07F8C20		RICFG0_OCU1CMP0EXT XXXXXXXX 00000000
0xB07F8C22		RICFG0_OCU1FRTSEL XXXXXXXX 00000000
0xB07F8C24		RICFG0_OCU1OTD0GATE XXXXXXXX 00000000
0xB07F8C26		RICFG0_OCU1OTD0GM XXXXXXXX 00000000
0xB07F8C28		RICFG0_OCU1OTD1GATE XXXXXXXX 00000000

Table 35. Memory Layout of PERI0_RBUS Registers with Default Values (Continued)

Offset	+1	+0
0xB07F8C2A		RICFG0_OCU1OTD1GM XXXXXXXX 00000000
0xB07F8C2C- B07F93FE		reserved XXXXXXXX 00000000
0xB07F9400		RICFG0_USART0SCKI 00000000 XXXXXXXX
0xB07F9402		RICFG0_USART0SIN 00000000 XXXXXXXX
0xB07F9404- B07F9BFE		reserved XXXXXXXX 00000000
0xB07F9C00		RICFG0_PPG0PPGAGATE XXXXXXXX 00000000
0xB07F9C02		RICFG0_PPG0PPGAGM XXXXXXXX 00000000
0xB07F9C04		RICFG0_PPG0PPGBGATE XXXXXXXX 00000000
0xB07F9C06		RICFG0_PPG0PPGBGM XXXXXXXX 00000000
0xB07F9C08- B07F9C1E		reserved XXXXXXXX 00000000
0xB07F9C20		RICFG0_PPG1PPGAGATE XXXXXXXX 00000000
0xB07F9C22		RICFG0_PPG1PPGAGM XXXXXXXX 00000000
0xB07F9C24		RICFG0_PPG1PPGBGATE XXXXXXXX 00000000
0xB07F9C26		RICFG0_PPG1PPGBGM XXXXXXXX 00000000
0xB07F9C28- B07F9C3E		reserved XXXXXXXX 00000000
0xB07F9C40		RICFG0_PPG2PPGAGATE XXXXXXXX 00000000
0xB07F9C42		RICFG0_PPG2PPGAGM XXXXXXXX 00000000
0xB07F9C44		RICFG0_PPG2PPGBGATE XXXXXXXX 00000000
0xB07F9C46		RICFG0_PPG2PPGBGM XXXXXXXX 00000000
0xB07F9C48- B07F9C5E		reserved XXXXXXXX 00000000
0xB07F9C60		RICFG0_PPG3PPGAGATE XXXXXXXX 00000000
0xB07F9C62		RICFG0_PPG3PPGAGM XXXXXXXX 00000000
0xB07F9C64		RICFG0_PPG3PPGBGATE XXXXXXXX 00000000
0xB07F9C66		RICFG0_PPG3PPGBGM XXXXXXXX 00000000
0xB07F9C68- B07F9C7E		reserved XXXXXXXX 00000000
0xB07F9C80		RICFG0_PPG4PPGAGATE XXXXXXXX 00000000

Table 35. Memory Layout of PERI0_RBUS Registers with Default Values (Continued)

Offset	+1	+0
0xB07F9C82		RICFG0_PPG4PPGAGM XXXXXXXX 00000000
0xB07F9C84		RICFG0_PPG4PPGBGATE XXXXXXXX 00000000
0xB07F9C86		RICFG0_PPG4PPGBGM XXXXXXXX 00000000
0xB07F9C88- B07F9C9E		reserved XXXXXXXX 00000000
0xB07F9CA0		RICFG0_PPG5PPGAGATE XXXXXXXX 00000000
0xB07F9CA2		RICFG0_PPG5PPGAGM XXXXXXXX 00000000
0xB07F9CA4		RICFG0_PPG5PPGBGATE XXXXXXXX 00000000
0xB07F9CA6		RICFG0_PPG5PPGBGM XXXXXXXX 00000000
0xB07F9CA8- B07F9CBE		reserved XXXXXXXX 00000000
0xB07F9CC0		RICFG0_PPG6PPGAGATE XXXXXXXX 00000000
0xB07F9CC2		RICFG0_PPG6PPGAGM XXXXXXXX 00000000
0xB07F9CC4		RICFG0_PPG6PPGBGATE XXXXXXXX 00000000
0xB07F9CC6		RICFG0_PPG6PPGBGM XXXXXXXX 00000000
0xB07F9CC8- B07F9CDE		reserved XXXXXXXX 00000000
0xB07F9CE0		RICFG0_PPG7PPGAGATE XXXXXXXX 00000000
0xB07F9CE2		RICFG0_PPG7PPGAGM XXXXXXXX 00000000
0xB07F9CE4		RICFG0_PPG7PPGBGATE XXXXXXXX 00000000
0xB07F9CE6		RICFG0_PPG7PPGBGM XXXXXXXX 00000000
0xB07F9CE8- B07F9CFE		reserved XXXXXXXX 00000000
0xB07F9D00		RICFG0_PPG8PPGAGATE XXXXXXXX 00000000
0xB07F9D02		RICFG0_PPG8PPGAGM XXXXXXXX 00000000
0xB07F9D04		RICFG0_PPG8PPGBGATE XXXXXXXX 00000000
0xB07F9D06		RICFG0_PPG8PPGBGM XXXXXXXX 00000000
0xB07F9D08- B07F9D1E		reserved XXXXXXXX 00000000
0xB07F9D20		RICFG0_PPG9PPGAGATE XXXXXXXX 00000000
0xB07F9D22		RICFG0_PPG9PPGAGM XXXXXXXX 00000000

Table 35. Memory Layout of PERI0_RBUS Registers with Default Values (Continued)

Offset	+1	+0
0xB07F9D24		RICFG0_PPG9PPGBGATE XXXXXXXX 00000000
0xB07F9D26		RICFG0_PPG9PPGBGM XXXXXXXX 00000000
0xB07F9D28- B07F9D3E		reserved XXXXXXXX 00000000
0xB07F9D40		RICFG0_PPG10PPGAGATE XXXXXXXX 00000000
0xB07F9D42		RICFG0_PPG10PPGAGM XXXXXXXX 00000000
0xB07F9D44		RICFG0_PPG10PPGBGATE XXXXXXXX 00000000
0xB07F9D46		RICFG0_PPG10PPGBGM XXXXXXXX 00000000
0xB07F9D48- B07F9D5E		reserved XXXXXXXX 00000000
0xB07F9D60		RICFG0_PPG11PPGAGATE XXXXXXXX 00000000
0xB07F9D62		RICFG0_PPG11PPGAGM XXXXXXXX 00000000
0xB07F9D64		RICFG0_PPG11PPGBGATE XXXXXXXX 00000000
0xB07F9D66		RICFG0_PPG11PPGBGM XXXXXXXX 00000000
0xB07F9D68- B07F9D7E		reserved XXXXXXXX 00000000
0xB07F9D80		RICFG0_PPG12PPGAGATE XXXXXXXX 00000000
0xB07F9D82		RICFG0_PPG12PPGAGM XXXXXXXX 00000000
0xB07F9D84		RICFG0_PPG12PPGBGATE XXXXXXXX 00000000
0xB07F9D86		RICFG0_PPG12PPGBGM XXXXXXXX 00000000
0xB07F9D88- B07F9D9E		reserved XXXXXXXX 00000000
0xB07F9DA0		RICFG0_PPG13PPGAGATE XXXXXXXX 00000000
0xB07F9DA2		RICFG0_PPG13PPGAGM XXXXXXXX 00000000
0xB07F9DA4		RICFG0_PPG13PPGBGATE XXXXXXXX 00000000
0xB07F9DA6		RICFG0_PPG13PPGBGM XXXXXXXX 00000000
0xB07F9DA8- B07F9DBE		reserved XXXXXXXX 00000000
0xB07F9DC0		RICFG0_PPG14PPGAGATE XXXXXXXX 00000000
0xB07F9DC2		RICFG0_PPG14PPGAGM XXXXXXXX 00000000
0xB07F9DC4		RICFG0_PPG14PPGBGATE XXXXXXXX 00000000

Table 35. Memory Layout of PERI0_RBUS Registers with Default Values (Continued)

Offset	+1	+0
0xB07F9DC6		RICFG0_PPG14PPGBGM XXXXXXXX 00000000
0xB07F9DC8- B07F9DDE		reserved XXXXXXXX 00000000
0xB07F9DE0		RICFG0_PPG15PPGAGATE XXXXXXXX 00000000
0xB07F9DE2		RICFG0_PPG15PPGAGM XXXXXXXX 00000000
0xB07F9DE4		RICFG0_PPG15PPGBGATE XXXXXXXX 00000000
0xB07F9DE6		RICFG0_PPG15PPGBGM XXXXXXXX 00000000
0xB07F9DE8- B07FA3FE		reserved XXXXXXXX 00000000
0xB07FA400		RICFG0_PPGGRP0ETRG0 XXXXXXXX 00000000
0xB07FA402		RICFG0_PPGGRP0ETRG1 XXXXXXXX 00000000
0xB07FA404		RICFG0_PPGGRP0ETRG2 XXXXXXXX 00000000
0xB07FA406		RICFG0_PPGGRP0ETRG3 XXXXXXXX 00000000
0xB07FA408		RICFG0_PPGGRP0RLTTRG1 XXXXXXXX 00000000
0xB07FA40A- B07FA41E		reserved XXXXXXXX 00000000
0xB07FA420		RICFG0_PPGGRP1ETRG0 XXXXXXXX 00000000
0xB07FA422		RICFG0_PPGGRP1ETRG1 XXXXXXXX 00000000
0xB07FA424		RICFG0_PPGGRP1ETRG2 XXXXXXXX 00000000
0xB07FA426		RICFG0_PPGGRP1ETRG3 XXXXXXXX 00000000
0xB07FA428		RICFG0_PPGGRP1RLTTRG1 XXXXXXXX 00000000
0xB07FA42A- B07FA43E		reserved XXXXXXXX 00000000
0xB07FA440		RICFG0_PPGGRP2ETRG0 XXXXXXXX 00000000
0xB07FA442		RICFG0_PPGGRP2ETRG1 XXXXXXXX 00000000
0xB07FA444		RICFG0_PPGGRP2ETRG2 XXXXXXXX 00000000
0xB07FA446		RICFG0_PPGGRP2ETRG3 XXXXXXXX 00000000
0xB07FA448		RICFG0_PPGGRP2RLTTRG1 XXXXXXXX 00000000
0xB07FA44A- B07FA45E		reserved XXXXXXXX 00000000
0xB07FA460		RICFG0_PPGGRP3ETRG0 XXXXXXXX 00000000

Table 35. Memory Layout of PERI0_RBUS Registers with Default Values (Continued)

Offset	+1	+0
0xB07FA462		RICFG0_PPGGRP3ETRG1 XXXXXXXX 00000000
0xB07FA464		RICFG0_PPGGRP3ETRG2 XXXXXXXX 00000000
0xB07FA466		RICFG0_PPGGRP3ETRG3 XXXXXXXX 00000000
0xB07FA468		RICFG0_PPGGRP3RLTTRG1 XXXXXXXX 00000000
0xB07FA46A- B07FFC02		reserved XXXXXXXX XXXXXXXX
0xB07FFC04		BSU0_BTSTL 00000000 00000000
0xB07FFC06		BSU0_BTSTH 00000000 00000000
0xB07FFC08- B07FFC0E		reserved XXXXXXXX XXXXXXXX
0xB07FFC10		BSU0_PEN0L XXXXXXXX 00000000
0xB07FFC12		reserved XXXXXXXX XXXXXXXX
0xB07FFC14		BSU0_PEN1L 00000000 00000000
0xB07FFC16		reserved XXXXXXXX XXXXXXXX
0xB07FFC18		BSU0_PEN2L 00000000 00000000
0xB07FFC1A		reserved XXXXXXXX XXXXXXXX
0xB07FFC1C		BSU0_PEN3L 00000000 00000000
0xB07FFC1E		reserved XXXXXXXX XXXXXXXX
0xB07FFC20		BSU0_PEN4L XXXXXXXX 00000000
0xB07FFC22		reserved XXXXXXXX XXXXXXXX
0xB07FFC24		BSU0_PEN5L XXXXXXXX 00000000
0xB07FFC26		reserved XXXXXXXX XXXXXXXX
0xB07FFC28		BSU0_PEN6L XXXXXXXX 00000000
0xB07FFC2A		reserved XXXXXXXX XXXXXXXX
0xB07FFC2C		BSU0_PEN7L 00000000 00000000
0xB07FFC2E		BSU0_PEN7H 00000000 00000000
0xB07FFC30		BSU0_PEN8L 00000000 00000000
0xB07FFC32		BSU0_PEN8H 00000000 00000000

Table 35. Memory Layout of PERI0_RBUS Registers with Default Values (Continued)

Offset	+1	+0
0xB07FFC34	BSU0_PEN9L 00000000 00000000	
0xB07FFC36	BSU0_PEN9H XXXXXXXX 00000000	
0xB07FFC38- B07FFC3A	reserved XXXXXXXX XXXXXXXX	
0xB07FFC3C	BSU0_PEN11L XXXXXXXX 00000000	
0xB07FFC3E- B07FFFE	reserved XXXXXXXX XXXXXXXX	

Table 36. Memory Layout of PERI1_RBUS Registers with Default Values

Offset	+1	+0
0xB0800000	SG0_CR0 00000000 00000000	
0xB0800002	reserved XXXXXXXX	SG0_CR1 00000000
0xB0800004	SG0_ECRL 00000000 00000000	
0xB0800006	SG0_FRL 00000000 00000000	
0xB0800008	SG0_ARL 00000000 00000000	
0xB080000A	SG0_AR 00000000 00000000	
0xB080000C	SG0_TARL 00000000 00000000	
0xB080000E	SG0_TCRLIDRL 00000000 00000000	
0xB0800010	reserved XXXXXXXX	SG0_NRL 00000000
0xB0800012	SG0_DER 00000000 00000000	
0xB0800014	SG0_DMAR 00000000 00000000	
0xB0800016- B0807FFE	reserved XXXXXXXX XXXXXXXX	
0xB0808000	CAN0_CTRLR XXXXXXXX 000X0001	
0xB0808002	CAN0_STATR XXXXXXXX 00000000	
0xB0808004	CAN0_ERRCNT 00000000 00000000	
0xB0808006	CAN0_BTR X0100011 00000001	
0xB0808008	CAN0_INTR 00000000 00000000	
0xB080800A	CAN0_TESTR XXXXXXXX 000000XX	
0xB080800C	CAN0_BRPER XXXXXXXX XXXX0000	
0xB080800E	reserved XXXXXXXX XXXXXXXX	
0xB0808010	CAN0_IF1CREQ 0XXXXXXXX 00000001	
0xB0808012	CAN0_IF1CMSK XXXXXXXX 00000000	
0xB0808014	CAN0_IF1MSK1 11111111 11111111	
0xB0808016	CAN0_IF1MSK2 11X11111 11111111	
0xB0808018	CAN0_IF1ARB1 00000000 00000000	
0xB080801A	CAN0_IF1ARB2 00000000 00000000	

Table 36. Memory Layout of PER11_RBUS Registers with Default Values (Continued)

Offset	+1	+0
0xB080801C		CAN0_IF1MCTR 00000000 0XXX0000
0xB080801E		reserved XXXXXXXX XXXXXXXX
0xB0808020		CAN0_IF1DTA1 00000000 00000000
0xB0808022		CAN0_IF1DTA2 00000000 00000000
0xB0808024		CAN0_IF1DTB1 00000000 00000000
0xB0808026		CAN0_IF1DTB2 00000000 00000000
0xB0808028- B080803E		reserved XXXXXXXX XXXXXXXX
0xB0808040		CAN0_IF2CREQ 0XXXXXXX 00000001
0xB0808042		CAN0_IF2CMASK XXXXXXXX 00000000
0xB0808044		CAN0_IF2MSK1 11111111 11111111
0xB0808046		CAN0_IF2MSK2 11X11111 11111111
0xB0808048		CAN0_IF2ARB1 00000000 00000000
0xB080804A		CAN0_IF2ARB2 00000000 00000000
0xB080804C		CAN0_IF2MCTR 00000000 00000000
0xB080804E		reserved XXXXXXXX XXXXXXXX
0xB0808050		CAN0_IF2DTA1 00000000 00000000
0xB0808052		CAN0_IF2DTA2 00000000 00000000
0xB0808054		CAN0_IF2DTB1 00000000 00000000
0xB0808056		CAN0_IF2DTB2 00000000 00000000
0xB0808058- B080807E		reserved XXXXXXXX XXXXXXXX
0xB0808080		CAN0_TREQR1 00000000 00000000
0xB0808082		CAN0_TREQR2 00000000 00000000
0xB0808084		CAN0_TREQR3 00000000 00000000
0xB0808086		CAN0_TREQR4 00000000 00000000
0xB0808088- B080808E		reserved XXXXXXXX XXXXXXXX
0xB0808090		CAN0_NEWDT1 00000000 00000000

Table 36. Memory Layout of PER11_RBUS Registers with Default Values (Continued)

Offset	+1	+0
0xB0808092	CAN0_NEWDT2 00000000 00000000	
0xB0808094	CAN0_NEWDT3 00000000 00000000	
0xB0808096	CAN0_NEWDT4 00000000 00000000	
0xB0808098- B080809E	reserved XXXXXXXX XXXXXXXX	
0xB08080A0	CAN0_INTPND1 00000000 00000000	
0xB08080A2	CAN0_INTPND2 00000000 00000000	
0xB08080A4	CAN0_INTPND3 00000000 00000000	
0xB08080A6	CAN0_INTPND4 00000000 00000000	
0xB08080A8- B08080AE	reserved XXXXXXXX XXXXXXXX	
0xB08080B0	CAN0_MSGVAL1 00000000 00000000	
0xB08080B2	CAN0_MSGVAL2 00000000 00000000	
0xB08080B4	CAN0_MSGVAL3 00000000 00000000	
0xB08080B6	CAN0_MSGVAL4 00000000 00000000	
0xB08080B8- B08080CC	reserved XXXXXXXX XXXXXXXX	
0xB08080CE	reserved 00000000	CAN0_COER XXXXXX0
0xB08080D0	CAN0_DEBUG XXXXXXXX 00000000	
0xB08080D2- B08083FE	reserved XXXXXXXX XXXXXXXX	
0xB0808400	CAN1_CTRLR XXXXXXXX 000X0001	
0xB0808402	CAN1_STATR XXXXXXXX 00000000	
0xB0808404	CAN1_ERRCNT 00000000 00000000	
0xB0808406	CAN1_BTR X0100011 00000001	
0xB0808408	CAN1_INTR 00000000 00000000	
0xB080840A	CAN1_TESTR XXXXXXXX 000000XX	
0xB080840C	CAN1_BRPER XXXXXXXX XXXX0000	
0xB080840E	reserved XXXXXXXX XXXXXXXX	
0xB0808410	CAN1_IF1CREQ XXXXXXXX 00000001	

Table 36. Memory Layout of PER11_RBUS Registers with Default Values (Continued)

Offset	+1	+0
0xB0808412		CAN1_IF1CMSK XXXXXXXX 00000000
0xB0808414		CAN1_IF1MSK1 11111111 11111111
0xB0808416		CAN1_IF1MSK2 11X11111 11111111
0xB0808418		CAN1_IF1ARB1 00000000 00000000
0xB080841A		CAN1_IF1ARB2 00000000 00000000
0xB080841C		CAN1_IF1MCTR 00000000 0XXX0000
0xB080841E		reserved XXXXXXXX XXXXXXXX
0xB0808420		CAN1_IF1DTA1 00000000 00000000
0xB0808422		CAN1_IF1DTA2 00000000 00000000
0xB0808424		CAN1_IF1DTB1 00000000 00000000
0xB0808426		CAN1_IF1DTB2 00000000 00000000
0xB0808428- B080843E		reserved XXXXXXXX XXXXXXXX
0xB0808440		CAN1_IF2CREQ 0XXXXXXXX 00000001
0xB0808442		CAN1_IF2CMSK XXXXXXXX 00000000
0xB0808444		CAN1_IF2MSK1 11111111 11111111
0xB0808446		CAN1_IF2MSK2 11X11111 11111111
0xB0808448		CAN1_IF2ARB1 00000000 00000000
0xB080844A		CAN1_IF2ARB2 00000000 00000000
0xB080844C		CAN1_IF2MCTR 00000000 00000000
0xB080844E		reserved XXXXXXXX XXXXXXXX
0xB0808450		CAN1_IF2DTA1 00000000 00000000
0xB0808452		CAN1_IF2DTA2 00000000 00000000
0xB0808454		CAN1_IF2DTB1 00000000 00000000
0xB0808456		CAN1_IF2DTB2 00000000 00000000
0xB0808458- B080847E		reserved XXXXXXXX XXXXXXXX
0xB0808480		CAN1_TREQR1 00000000 00000000

Table 36. Memory Layout of PER11_RBUS Registers with Default Values (Continued)

Offset	+1	+0
0xB0808482	CAN1_TREQR2 00000000 00000000	
0xB0808484	CAN1_TREQR3 00000000 00000000	
0xB0808486	CAN1_TREQR4 00000000 00000000	
0xB0808488- B080848E	reserved XXXXXXXX XXXXXXXX	
0xB0808490	CAN1_NEWDT1 00000000 00000000	
0xB0808492	CAN1_NEWDT2 00000000 00000000	
0xB0808494	CAN1_NEWDT3 00000000 00000000	
0xB0808496	CAN1_NEWDT4 00000000 00000000	
0xB0808498- B080849E	reserved XXXXXXXX XXXXXXXX	
0xB08084A0	CAN1_INTPND1 00000000 00000000	
0xB08084A2	CAN1_INTPND2 00000000 00000000	
0xB08084A4	CAN1_INTPND3 00000000 00000000	
0xB08084A6	CAN1_INTPND4 00000000 00000000	
0xB08084A8- B08084AE	reserved XXXXXXXX XXXXXXXX	
0xB08084B0	CAN1_MSGVAL1 00000000 00000000	
0xB08084B2	CAN1_MSGVAL2 00000000 00000000	
0xB08084B4	CAN1_MSGVAL3 00000000 00000000	
0xB08084B6	CAN1_MSGVAL4 00000000 00000000	
0xB08084B8- B08084CC	reserved XXXXXXXX XXXXXXXX	
0xB08084CE	reserved 00000000	CAN1_COER XXXXXXX0
0xB08084D0	CAN1_DEBUG XXXXXXXX 00000000	
0xB08084D2- B0817FFE	reserved XXXXXXXX XXXXXXXX	
0xB0818000	FRT16_TCDT 00000000 00000000	
0xB0818002	FRT16_CPCLRB 11111111 11111111	
0xB0818004	FRT16_CPCLR 11111111 11111111	
0xB0818006	FRT16_TCCS 00000000 00000000	

Table 36. Memory Layout of PER11_RBUS Registers with Default Values (Continued)

Offset	+1	+0
0xB0818008	FRT16_TSTPTCLK 01000000 00000000	
0xB081800A	FRT16_ETCCS 00000000 00000000	
0xB081800C	FRT16_CIMSZIMS 00000000 00000000	
0xB081800E	reserved XXXXXXXX	FRT16_DMACFG 00000000
0xB0818010- B08183FE	reserved XXXXXXXX XXXXXXXX	
0xB0818400	FRT17_TCDT 00000000 00000000	
0xB0818402	FRT17_CPCLRB 11111111 11111111	
0xB0818404	FRT17_CPCLR 11111111 11111111	
0xB0818406	FRT17_TCCS 00000000 00000000	
0xB0818408	FRT17_TSTPTCLK 01000000 00000000	
0xB081840A	FRT17_ETCCS 00000000 00000000	
0xB081840C	FRT17_CIMSZIMS 00000000 00000000	
0xB081840E	reserved XXXXXXXX	FRT17_DMACFG 00000000
0xB0818410- B08187FE	reserved XXXXXXXX XXXXXXXX	
0xB0818800	FRT18_TCDT 00000000 00000000	
0xB0818802	FRT18_CPCLRB 11111111 11111111	
0xB0818804	FRT18_CPCLR 11111111 11111111	
0xB0818806	FRT18_TCCS 00000000 00000000	
0xB0818808	FRT18_TSTPTCLK 01000000 00000000	
0xB081880A	FRT18_ETCCS 00000000 00000000	
0xB081880C	FRT18_CIMSZIMS 00000000 00000000	
0xB081880E	reserved XXXXXXXX	FRT18_DMACFG 00000000
0xB0818810- B0818BFE	reserved XXXXXXXX XXXXXXXX	
0xB0818C00	FRT19_TCDT 00000000 00000000	
0xB0818C02	FRT19_CPCLRB 11111111 11111111	
0xB0818C04	FRT19_CPCLR 11111111 11111111	

Table 36. Memory Layout of PER11_RBUS Registers with Default Values (Continued)

Offset	+1	+0
0xB0818C06	FRT19_TCCS 00000000 00000000	
0xB0818C08	FRT19_TSTPTCLK 01000000 00000000	
0xB0818C0A	FRT19_ETCCS 00000000 00000000	
0xB0818C0C	FRT19_CIMSZIMS 00000000 00000000	
0xB0818C0E	reserved XXXXXXXX	FRT19_DMACFG 00000000
0xB0818C10- B08207FE	reserved XXXXXXXX XXXXXXXX	
0xB0820800	ICU18_IPC0 00000000 00000000	
0xB0820802	ICU18_IPC1 00000000 00000000	
0xB0820804	ICU18_ICC01 00000000 00000000	
0xB0820806	ICU18_ICEICS01 00000000 00000000	
0xB0820808	ICU18_DEBUG01 00000000	ICU18_DMACFG01 00000000
0xB082080A- B0820BFE	reserved XXXXXXXX XXXXXXXX	
0xB0820C00	ICU19_IPC0 00000000 00000000	
0xB0820C02	ICU19_IPC1 00000000 00000000	
0xB0820C04	ICU19_ICC01 00000000 00000000	
0xB0820C06	ICU19_ICEICS01 00000000 00000000	
0xB0820C08	ICU19_DEBUG01 00000000	ICU19_DMACFG01 00000000
0xB0820C0A- B0827FFE	reserved XXXXXXXX XXXXXXXX	
0xB0828000	OCU16_OCCP0 00000000 00000000	
0xB0828002	OCU16_OCCP1 00000000 00000000	
0xB0828004	OCU16_OCCPB0 00000000 00000000	
0xB0828006	OCU16_OCCPB1 00000000 00000000	
0xB0828008	OCU16_OCCPBD0 00000000 00000000	
0xB082800A	OCU16_OCCPBD1 00000000 00000000	
0xB082800C	OCU16_OCS01 00000000 00000000	
0xB082800E	OCU16_OCSC01 00000000 00000000	

Table 36. Memory Layout of PER11_RBUS Registers with Default Values (Continued)

Offset	+1	+0
0xB0828010	OCU16_OCSS01 00000000 00000000	
0xB0828012	reserved XXXXXXXX	OCU16_OSR01 00000000
0xB0828014	reserved XXXXXXXX	OCU16_OSCR01 00000000
0xB0828016	OCU16_EOCS01 00000000 00000000	
0xB0828018	OCU16_EOCSSH01 00000000	reserved XXXXXXXX
0xB082801A	OCU16_EOCSCH01 00000000	reserved XXXXXXXX
0xB082801C	OCU16_DEBUG01 00000000	OCU16_DMACFG01 00000000
0xB082801E	OCU16_OCMCR01 00000000	reserved XXXXXXXX
0xB0828020- B08283FE	reserved XXXXXXXX XXXXXXXX	
0xB0828400	OCU17_OCCP0 00000000 00000000	
0xB0828402	OCU17_OCCP1 00000000 00000000	
0xB0828404	OCU17_OCCPB0 00000000 00000000	
0xB0828406	OCU17_OCCPB1 00000000 00000000	
0xB0828408	OCU17_OCCPBD0 00000000 00000000	
0xB082840A	OCU17_OCCPBD1 00000000 00000000	
0xB082840C	OCU17_OCS01 00000000 00000000	
0xB082840E	OCU17_OCSC01 00000000 00000000	
0xB0828410	OCU17_OCSS01 00000000 00000000	
0xB0828412	reserved XXXXXXXX	OCU17_OSR01 00000000
0xB0828414	reserved XXXXXXXX	OCU17_OSCR01 00000000
0xB0828416	OCU17_EOCS01 00000000 00000000	
0xB0828418	OCU17_EOCSSH01 00000000	reserved XXXXXXXX
0xB082841A	OCU17_EOCSCH01 00000000	reserved XXXXXXXX
0xB082841C	OCU17_DEBUG01 00000000	OCU17_DMACFG01 00000000
0xB082841E	OCU17_OCMCR01 00000000	reserved XXXXXXXX
0xB0828420- B0837FFE	reserved XXXXXXXX XXXXXXXX	

Table 36. Memory Layout of PER11_RBUS Registers with Default Values (Continued)

Offset	+1	+0
0xB0838000	USART6_SCR 00000000	USART6_SMR 00000000
0xB0838002	USART6_SCSR 00000000	USART6_SMSR 00000000
0xB0838004	USART6_SCCR 00000000	reserved XXXXXXXX
0xB0838006	USART6_SSR 00001000	USART6_TDR 00000000
0xB0838008	USART6_SSSR 00000000	USART6_RDR 00000000
0xB083800A	USART6_SSCR 00000000	reserved XXXXXXXX
0xB083800C	USART6_ESCR 00000100	USART6_ECCR 000000XX
0xB083800E	USART6_ESCSR 00000000	USART6_ECCSR 00000000
0xB0838010	USART6_ESCCR 00000000	USART6_ECCCR 00000000
0xB0838012	USART6_EIER 00000000	USART6_ESIR 000010X0
0xB0838014	USART6_EIESR 00000000	USART6_ESISR 00000000
0xB0838016	USART6_EIECR 00000000	USART6_ESICR 00000000
0xB0838018	USART6_EFERH 00000000	USART6_EFERL 00000000
0xB083801A	USART6_TFCR 00000000	USART6_RFCR 00000000
0xB083801C	USART6_TFCR 00000000	USART6_RFCSR 00000000
0xB083801E	USART6_TFCCR 00000000	USART6_RFCCR 00000000
0xB0838020	USART6_TFSR 00000000	USART6_RFSR 00000000
0xB0838022	USART6_ESR 00000000	USART6_CSCR 00000000
0xB0838024	reserved XXXXXXXX	USART6_CSCSR 00000000
0xB0838026	USART6_ESCLR 00000000	USART6_CSCCR 00000000
0xB0838028	USART6_BGRLM 00000000	USART6_BGRLL 00000000
0xB083802A	reserved XXXXXXXX	USART6_BGRLH 00000000
0xB083802C	USART6_BGRM 00000000	USART6_BGRL 00000000
0xB083802E	reserved XXXXXXXX	USART6_BGRH 00000000
0xB0838030	USART6_SRXRDR 00000000	USART6_STXRDR 00000000

Table 36. Memory Layout of PER11_RBUS Registers with Default Values (Continued)

Offset	+1	+0
0xB0838032	USART6_SRXDSR 00000000	USART6_STXDSR 00000000
0xB0838034	USART6_SRXDCR 00000000	USART6_STXDCR 00000000
0xB0838036	read0 00000000	read0 00000000
0xB0838038	reserved XXXXXXXX	read0 00000000
0xB083803A	reserved XXXXXXXX	USART6_FIDR 00000000
0xB083803C	reserved XXXXXXXX	USART6_DEBUG 00000000
0xB083803E- B0847FFE	reserved XXXXXXXX XXXXXXXX	
0xB0848000	PPG64_PCN 00000000 00000000	
0xB0848002	PPG64_SWTRIG 00000000	PPG64_IRQCLR 00000000
0xB0848004	PPG64_CNTEN 00000000	PPG64_OE 00000000
0xB0848006	PPG64_RMPCFG 00000000	PPG64_OPTMSK 00000000
0xB0848008	PPG64_TRIGCLR 00000000	PPG64_STRD 00000000
0xB084800A	PPG64_EPCN1 00000000 00000000	
0xB084800C	PPG64_EPCN2 00000000 00000000	
0xB084800E	PPG64_GC3 00000000	PPG64_GC1 00000000
0xB0848010	PPG64_GC5 00000000	PPG64_GC4 00000110
0xB0848012	PPG64_PCSR XXXXXXXX XXXXXXXX	
0xB0848014	PPG64_PDUT XXXXXXXX XXXXXXXX	
0xB0848016	PPG64_PTMR 11111111 11111111	
0xB0848018	PPG64_PSDR 00000000 00000000	
0xB084801A	PPG64_PTPC 00000000 00000000	
0xB084801C	PPG64_PEDR 00000000 00000000	
0xB084801E	PPG64_DEBUG 00000000	PPG64_DMACFG 00000000
0xB0848020- B08483FE	reserved XXXXXXXX XXXXXXXX	
0xB0848400	PPG65_PCN 00000000 00000000	
0xB0848402	PPG65_SWTRIG 00000000	PPG65_IRQCLR 00000000

Table 36. Memory Layout of PER11_RBUS Registers with Default Values (Continued)

Offset	+1	+0
0xB0848404	PPG65_CNTEN 00000000	PPG65_OE 00000000
0xB0848406	PPG65_RMPCFG 00000000	PPG65_OPTMSK 00000000
0xB0848408	PPG65_TRIGCLR 00000000	PPG65_STRD 00000000
0xB084840A	PPG65_EPCN1 00000000 00000000	
0xB084840C	PPG65_EPCN2 00000000 00000000	
0xB084840E	PPG65_GC3 00000000	PPG65_GC1 00000000
0xB0848410	PPG65_GC5 00000000	PPG65_GC4 00000110
0xB0848412	PPG65_PCSR XXXXXXXX XXXXXXXX	
0xB0848414	PPG65_PDUT XXXXXXXX XXXXXXXX	
0xB0848416	PPG65_PTMR 11111111 11111111	
0xB0848418	PPG65_PSDR 00000000 00000000	
0xB084841A	PPG65_PTPC 00000000 00000000	
0xB084841C	PPG65_PEDR 00000000 00000000	
0xB084841E	PPG65_DEBUG 00000000	PPG65_DMACFG 00000000
0xB0848420- B08487FE	reserved XXXXXXXX XXXXXXXX	
0xB0848800	PPG66_PCN 00000000 00000000	
0xB0848802	PPG66_SWTRIG 00000000	PPG66_IRQCLR 00000000
0xB0848804	PPG66_CNTEN 00000000	PPG66_OE 00000000
0xB0848806	PPG66_RMPCFG 00000000	PPG66_OPTMSK 00000000
0xB0848808	PPG66_TRIGCLR 00000000	PPG66_STRD 00000000
0xB084880A	PPG66_EPCN1 00000000 00000000	
0xB084880C	PPG66_EPCN2 00000000 00000000	
0xB084880E	PPG66_GC3 00000000	PPG66_GC1 00000000
0xB0848810	PPG66_GC5 00000000	PPG66_GC4 00000110
0xB0848812	PPG66_PCSR XXXXXXXX XXXXXXXX	
0xB0848814	PPG66_PDUT XXXXXXXX XXXXXXXX	

Table 36. Memory Layout of PER11_RBUS Registers with Default Values (Continued)

Offset	+1	+0
0xB0848816	PPG66_PTMR 11111111 11111111	
0xB0848818	PPG66_PSDR 00000000 00000000	
0xB084881A	PPG66_PTPC 00000000 00000000	
0xB084881C	PPG66_PEDR 00000000 00000000	
0xB084881E	PPG66_DEBUG 00000000	PPG66_DMACFG 00000000
0xB0848820- B0848BFE	reserved XXXXXXXX XXXXXXXX	
0xB0848C00	PPG67_PCN 00000000 00000000	
0xB0848C02	PPG67_SWTRIG 00000000	PPG67_IRQCLR 00000000
0xB0848C04	PPG67_CNTEN 00000000	PPG67_OE 00000000
0xB0848C06	PPG67_RMPCFG 00000000	PPG67_OPTMSK 00000000
0xB0848C08	PPG67_TRIGCLR 00000000	PPG67_STRD 00000000
0xB0848C0A	PPG67_EPCN1 00000000 00000000	
0xB0848C0C	PPG67_EPCN2 00000000 00000000	
0xB0848C0E	PPG67_GCN3 00000000	PPG67_GCN1 00000000
0xB0848C10	PPG67_GCN5 00000000	PPG67_GCN4 00000110
0xB0848C12	PPG67_PCSR XXXXXXXX XXXXXXXX	
0xB0848C14	PPG67_PDU1 XXXXXXXX XXXXXXXX	
0xB0848C16	PPG67_PTMR 11111111 11111111	
0xB0848C18	PPG67_PSDR 00000000 00000000	
0xB0848C1A	PPG67_PTPC 00000000 00000000	
0xB0848C1C	PPG67_PEDR 00000000 00000000	
0xB0848C1E	PPG67_DEBUG 00000000	PPG67_DMACFG 00000000
0xB0848C20- B0848FFE	reserved XXXXXXXX XXXXXXXX	
0xB0849000	PPG68_PCN 00000000 00000000	
0xB0849002	PPG68_SWTRIG 00000000	PPG68_IRQCLR 00000000
0xB0849004	PPG68_CNTEN 00000000	PPG68_OE 00000000

Table 36. Memory Layout of PER11_RBUS Registers with Default Values (Continued)

Offset	+1	+0
0xB0849006	PPG68_RMPCFG 00000000	PPG68_OPTMSK 00000000
0xB0849008	PPG68_TRIGCLR 00000000	PPG68_STRD 00000000
0xB084900A	PPG68_EPCN1 00000000 00000000	
0xB084900C	PPG68_EPCN2 00000000 00000000	
0xB084900E	PPG68_GC3 00000000	PPG68_GC1 00000000
0xB0849010	PPG68_GC5 00000000	PPG68_GC4 00000110
0xB0849012	PPG68_PCSR XXXXXXXX XXXXXXXX	
0xB0849014	PPG68_PDUT XXXXXXXX XXXXXXXX	
0xB0849016	PPG68_PTMR 11111111 11111111	
0xB0849018	PPG68_PSDR 00000000 00000000	
0xB084901A	PPG68_PTPC 00000000 00000000	
0xB084901C	PPG68_PEDR 00000000 00000000	
0xB084901E	PPG68_DEBUG 00000000	PPG68_DMACFG 00000000
0xB0849020- B08493FE	reserved XXXXXXXX XXXXXXXX	
0xB0849400	PPG69_PCN 00000000 00000000	
0xB0849402	PPG69_SWTRIG 00000000	PPG69_IRQCLR 00000000
0xB0849404	PPG69_CNTEN 00000000	PPG69_OE 00000000
0xB0849406	PPG69_RMPCFG 00000000	PPG69_OPTMSK 00000000
0xB0849408	PPG69_TRIGCLR 00000000	PPG69_STRD 00000000
0xB084940A	PPG69_EPCN1 00000000 00000000	
0xB084940C	PPG69_EPCN2 00000000 00000000	
0xB084940E	PPG69_GC3 00000000	PPG69_GC1 00000000
0xB0849410	PPG69_GC5 00000000	PPG69_GC4 00000110
0xB0849412	PPG69_PCSR XXXXXXXX XXXXXXXX	
0xB0849414	PPG69_PDUT XXXXXXXX XXXXXXXX	
0xB0849416	PPG69_PTMR 11111111 11111111	

Table 36. Memory Layout of PER11_RBUS Registers with Default Values (Continued)

Offset	+1	+0
0xB0849418	PPG69_PSDR 00000000 00000000	
0xB084941A	PPG69_PTPC 00000000 00000000	
0xB084941C	PPG69_PEDR 00000000 00000000	
0xB084941E	PPG69_DEBUG 00000000	PPG69_DMACFG 00000000
0xB0849420- B08497FE	reserved XXXXXXXX XXXXXXXX	
0xB0849800	PPG70_PC� 00000000 00000000	
0xB0849802	PPG70_SWTRIG 00000000	PPG70_IRQCLR 00000000
0xB0849804	PPG70_CNTEN 00000000	PPG70_OE 00000000
0xB0849806	PPG70_RMPCFG 00000000	PPG70_OPTMSK 00000000
0xB0849808	PPG70_TRIGCLR 00000000	PPG70_STRD 00000000
0xB084980A	PPG70_EPCN1 00000000 00000000	
0xB084980C	PPG70_EPCN2 00000000 00000000	
0xB084980E	PPG70_GCN3 00000000	PPG70_GCN1 00000000
0xB0849810	PPG70_GCN5 00000000	PPG70_GCN4 00000110
0xB0849812	PPG70_PCSR XXXXXXXX XXXXXXXX	
0xB0849814	PPG70_PDUT XXXXXXXX XXXXXXXX	
0xB0849816	PPG70_PTMR 11111111 11111111	
0xB0849818	PPG70_PSDR 00000000 00000000	
0xB084981A	PPG70_PTPC 00000000 00000000	
0xB084981C	PPG70_PEDR 00000000 00000000	
0xB084981E	PPG70_DEBUG 00000000	PPG70_DMACFG 00000000
0xB0849820- B0849BFE	reserved XXXXXXXX XXXXXXXX	
0xB0849C00	PPG71_PC� 00000000 00000000	
0xB0849C02	PPG71_SWTRIG 00000000	PPG71_IRQCLR 00000000
0xB0849C04	PPG71_CNTEN 00000000	PPG71_OE 00000000
0xB0849C06	PPG71_RMPCFG 00000000	PPG71_OPTMSK 00000000

Table 36. Memory Layout of PER11_RBUS Registers with Default Values (Continued)

Offset	+1	+0
0xB0849C08	PPG71_TRIGCLR 00000000	PPG71_STRD 00000000
0xB0849C0A	PPG71_EPCN1 00000000 00000000	
0xB0849C0C	PPG71_EPCN2 00000000 00000000	
0xB0849C0E	PPG71_GC3 00000000	PPG71_GC1 00000000
0xB0849C10	PPG71_GC5 00000000	PPG71_GC4 00000110
0xB0849C12	PPG71_PCSR XXXXXXXX XXXXXXXX	
0xB0849C14	PPG71_PDUT XXXXXXXX XXXXXXXX	
0xB0849C16	PPG71_PTMR 11111111 11111111	
0xB0849C18	PPG71_PSDR 00000000 00000000	
0xB0849C1A	PPG71_PTPC 00000000 00000000	
0xB0849C1C	PPG71_PEDR 00000000 00000000	
0xB0849C1E	PPG71_DEBUG 00000000	PPG71_DMACFG 00000000
0xB0849C20- B0857FFE	reserved XXXXXXXX XXXXXXXX	
0xB0858000	reserved XXXXXXXX	PPGGRP16_GCTRL 00000000
0xB0858002- B08583FE	reserved XXXXXXXX XXXXXXXX	
0xB0858400	reserved XXXXXXXX	PPGGRP17_GCTRL 00000000
0xB0858402- B085BFFE	reserved XXXXXXXX XXXXXXXX	
0xB085C000	reserved XXXXXXXX	PPGGLC1_GCNR 00000000
0xB085C002- B08EFFFF	reserved XXXXXXXX XXXXXXXX	
0xB08F0000	BECU1_CTRL 00000000 00000000	
0xB08F0002	BECU1_CTRH 00000000 00000000	
0xB08F0004	BECU1_ADDRL 00000000 00000000	
0xB08F0006	BECU1_ADDRH 00000000 00000000	
0xB08F0008	BECU1_DATALL 00000000 00000000	
0xB08F000A	BECU1_DATA LH 00000000 00000000	
0xB08F000C	BECU1_DATA HL 00000000 00000000	

Table 36. Memory Layout of PER11_RBUS Registers with Default Values (Continued)

Offset	+1	+0
0xB08F000E		BECU1_DATAHH 00000000 00000000
0xB08F0010		BECU1_MASTERID 00000000 00000000
0xB08F0012		BECU1_MIDL XXXXXXXX XXXXXXXX
0xB08F0014		BECU1_MIDH XXXXXXXX XXXXXXXX
0xB08F0016		reserved 00000000 00000000
0xB08F0018		BECU1_NMIEN XXXXXXXX 00000001
0xB08F001A- B08F83FE		reserved XXXXXXXX XXXXXXXX
0xB08F8400		RICFG1_CAN0RX 00000000 00000000
0xB08F8402- B08F841E		reserved XXXXXXXX 00000000
0xB08F8420		RICFG1_CAN1RX 00000000 00000000
0xB08F8422- B08F8BFE		reserved XXXXXXXX 00000000
0xB08F8C00		RICFG1_FRT16TEXT 00000000 00000000
0xB08F8C02- B08F8C1E		reserved XXXXXXXX 00000000
0xB08F8C20		RICFG1_FRT17TEXT 00000000 00000000
0xB08F8C22- B08F8C3E		reserved XXXXXXXX 00000000
0xB08F8C40		RICFG1_FRT18TEXT 00000000 00000000
0xB08F8C42- B08F8C5E		reserved XXXXXXXX 00000000
0xB08F8C60		RICFG1_FRT19TEXT 00000000 00000000
0xB08F8C62- B08F903E		reserved XXXXXXXX 00000000
0xB08F9040		RICFG1_ICU18IN0 00000000 XXXXXXXX
0xB08F9042		RICFG1_ICU18IN1 00000000 XXXXXXXX
0xB08F9044		RICFG1_ICU18FRTSEL XXXXXXXX 00000000
0xB08F9046- B08F905E		reserved XXXXXXXX 00000000
0xB08F9060		RICFG1_ICU19IN0 00000000 XXXXXXXX
0xB08F9062		RICFG1_ICU19IN1 00000000 XXXXXXXX
0xB08F9064		RICFG1_ICU19FRTSEL XXXXXXXX 00000000

Table 36. Memory Layout of PER11_RBUS Registers with Default Values (Continued)

Offset	+1	+0
0xB08F9066- B08F93FE		reserved XXXXXXXX 00000000
0xB08F9400		RICFG1_OCU16OTD0GATE XXXXXXXX 00000000
0xB08F9402		RICFG1_OCU16OTD0GM XXXXXXXX 00000000
0xB08F9404		RICFG1_OCU16OTD1GATE XXXXXXXX 00000000
0xB08F9406		RICFG1_OCU16OTD1GM XXXXXXXX 00000000
0xB08F9408- B08F941E		reserved XXXXXXXX 00000000
0xB08F9420		RICFG1_OCU17CMP0EXT XXXXXXXX 00000000
0xB08F9422		RICFG1_OCU17FRTSEL XXXXXXXX 00000000
0xB08F9424		RICFG1_OCU17OTD0GATE XXXXXXXX 00000000
0xB08F9426		RICFG1_OCU17OTD0GM XXXXXXXX 00000000
0xB08F9428		RICFG1_OCU17OTD1GATE XXXXXXXX 00000000
0xB08F942A		RICFG1_OCU17OTD1GM XXXXXXXX 00000000
0xB08F942C- B08F9BFE		reserved XXXXXXXX 00000000
0xB08F9C00		RICFG1_USART6SCKI 00000000 XXXXXXXX
0xB08F9C02		RICFG1_USART6SIN 00000000 XXXXXXXX
0xB08F9C04- B08FA3FE		reserved XXXXXXXX 00000000
0xB08FA400		RICFG1_PPG64PPGAGATE XXXXXXXX 00000000
0xB08FA402		RICFG1_PPG64PPGAGM XXXXXXXX 00000000
0xB08FA404		RICFG1_PPG64PPGBGATE XXXXXXXX 00000000
0xB08FA406		RICFG1_PPG64PPGBGM XXXXXXXX 00000000
0xB08FA408- B08FA41E		reserved XXXXXXXX 00000000
0xB08FA420		RICFG1_PPG65PPGAGATE XXXXXXXX 00000000
0xB08FA422		RICFG1_PPG65PPGAGM XXXXXXXX 00000000
0xB08FA424		RICFG1_PPG65PPGBGATE XXXXXXXX 00000000
0xB08FA426		RICFG1_PPG65PPGBGM XXXXXXXX 00000000
0xB08FA428- B08FA43E		reserved XXXXXXXX 00000000

Table 36. Memory Layout of PER11_RBUS Registers with Default Values (Continued)

Offset	+1	+0
0xB08FA440		RICFG1_PPG66PPGAGATE XXXXXXXX 00000000
0xB08FA442		RICFG1_PPG66PPGAGM XXXXXXXX 00000000
0xB08FA444		RICFG1_PPG66PPGBGATE XXXXXXXX 00000000
0xB08FA446		RICFG1_PPG66PPGBGM XXXXXXXX 00000000
0xB08FA448- B08FA45E		reserved XXXXXXXX 00000000
0xB08FA460		RICFG1_PPG67PPGAGATE XXXXXXXX 00000000
0xB08FA462		RICFG1_PPG67PPGAGM XXXXXXXX 00000000
0xB08FA464		RICFG1_PPG67PPGBGATE XXXXXXXX 00000000
0xB08FA466		RICFG1_PPG67PPGBGM XXXXXXXX 00000000
0xB08FA468- B08FA47E		reserved XXXXXXXX 00000000
0xB08FA480		RICFG1_PPG68PPGAGATE XXXXXXXX 00000000
0xB08FA482		RICFG1_PPG68PPGAGM XXXXXXXX 00000000
0xB08FA484		RICFG1_PPG68PPGBGATE XXXXXXXX 00000000
0xB08FA486		RICFG1_PPG68PPGBGM XXXXXXXX 00000000
0xB08FA488- B08FA49E		reserved XXXXXXXX 00000000
0xB08FA4A0		RICFG1_PPG69PPGAGATE XXXXXXXX 00000000
0xB08FA4A2		RICFG1_PPG69PPGAGM XXXXXXXX 00000000
0xB08FA4A4		RICFG1_PPG69PPGBGATE XXXXXXXX 00000000
0xB08FA4A6		RICFG1_PPG69PPGBGM XXXXXXXX 00000000
0xB08FA4A8- B08FA4BE		reserved XXXXXXXX 00000000
0xB08FA4C0		RICFG1_PPG70PPGAGATE XXXXXXXX 00000000
0xB08FA4C2		RICFG1_PPG70PPGAGM XXXXXXXX 00000000
0xB08FA4C4		RICFG1_PPG70PPGBGATE XXXXXXXX 00000000
0xB08FA4C6		RICFG1_PPG70PPGBGM XXXXXXXX 00000000
0xB08FA4C8- B08FA4DE		reserved XXXXXXXX 00000000
0xB08FA4E0		RICFG1_PPG71PPGAGATE XXXXXXXX 00000000

Table 36. Memory Layout of PER11_RBUS Registers with Default Values (Continued)

Offset	+1	+0
0xB08FA4E2		RICFG1_PPG71PPGAGM XXXXXXXX 00000000
0xB08FA4E4		RICFG1_PPG71PPGBGATE XXXXXXXX 00000000
0xB08FA4E6		RICFG1_PPG71PPGBGM XXXXXXXX 00000000
0xB08FA4E8- B08FABFE		reserved XXXXXXXX 00000000
0xB08FAC00		RICFG1_PPGGRP16ETRG0 XXXXXXXX 00000000
0xB08FAC02		RICFG1_PPGGRP16ETRG1 XXXXXXXX 00000000
0xB08FAC04		RICFG1_PPGGRP16ETRG2 XXXXXXXX 00000000
0xB08FAC06		RICFG1_PPGGRP16ETRG3 XXXXXXXX 00000000
0xB08FAC08		RICFG1_PPGGRP16RLTTRG1 XXXXXXXX 00000000
0xB08FAC0A- B08FAC1E		reserved XXXXXXXX 00000000
0xB08FAC20		RICFG1_PPGGRP17ETRG0 XXXXXXXX 00000000
0xB08FAC22		RICFG1_PPGGRP17ETRG1 XXXXXXXX 00000000
0xB08FAC24		RICFG1_PPGGRP17ETRG2 XXXXXXXX 00000000
0xB08FAC26		RICFG1_PPGGRP17ETRG3 XXXXXXXX 00000000
0xB08FAC28		RICFG1_PPGGRP17RLTTRG1 XXXXXXXX 00000000
0xB08FAC2A- B08FFC02		reserved XXXXXXXX XXXXXXXX
0xB08FFC04		BSU1_BTSTL 00000000 00000000
0xB08FFC06		BSU1_BTSTH 00000000 00000000
0xB08FFC08- B08FFC0E		reserved XXXXXXXX XXXXXXXX
0xB08FFC10		BSU1_PEN0L XXXXXXXX 00000000
0xB08FFC12		reserved XXXXXXXX XXXXXXXX
0xB08FFC14		BSU1_PEN1L XXXXXXXX 00000000
0xB08FFC16		reserved XXXXXXXX XXXXXXXX
0xB08FFC18		BSU1_PEN2L XXXXXXXX 00000000
0xB08FFC1A		reserved XXXXXXXX XXXXXXXX
0xB08FFC1C		BSU1_PEN3L 00000000 00000000

Table 36. Memory Layout of PER11_RBUS Registers with Default Values (Continued)

Offset	+1	+0
0xB08FFC1E		reserved XXXXXXXX XXXXXXXX
0xB08FFC20		BSU1_PEN4L 00000000 00000000
0xB08FFC22		reserved XXXXXXXX XXXXXXXX
0xB08FFC24		BSU1_PEN5L 00000000 00000000
0xB08FFC26		reserved XXXXXXXX XXXXXXXX
0xB08FFC28		BSU1_PEN6L XXXXXXXX 00000000
0xB08FFC2A		reserved XXXXXXXX XXXXXXXX
0xB08FFC2C		BSU1_PEN7L XXXXXXXX 00000000
0xB08FFC2E		reserved XXXXXXXX XXXXXXXX
0xB08FFC30		BSU1_PEN8L XXXXXXXX 00000000
0xB08FFC32		reserved XXXXXXXX XXXXXXXX
0xB08FFC34		BSU1_PEN9L 00000000 00000000
0xB08FFC36		BSU1_PEN9H 00000000 00000000
0xB08FFC38		BSU1_PEN10L 00000000 00000000
0xB08FFC3A		BSU1_PEN10H 00000000 00000000
0xB08FFC3C		BSU1_PEN11L 00000000 00000000
0xB08FFC3E		BSU1_PEN11H XXXXXXXX 00000000
0xB08FFC40- B09FFFE		reserved XXXXXXXX XXXXXXXX

Table 37. Memory Layout of PERI3_ERBUS Registers with Default Values

Offset	+7	+6	+5	+4	+3	+2	+1	+0
0xB0A00000	reserved XXXXXXXX XXXXXXXX XXXXXXXX XXXXXXXX XXXXXXXX XXXXXXXX XXXXXXXX XXXXXXXX							
0xB0A00008	PPU0_PRS3 00000000 00000000 00000000 00000000				PPU0_PRS2 00000000 00000000 00000000 00000000			
0xB0A00010	PPU0_PRS5 00000000 00000000 00000000 00000000				PPU0_PRS4 00000000 00000000 00000000 00000000			
0xB0A00018	PPU0_PRS7 00000000 00000000 00000000 00000000				PPU0_PRS6 00000000 00000000 00000000 00000000			
0xB0A00020	PPU0_PRS9 00000000 00000000 00000000 00000000				PPU0_PRS8 00000000 00000000 00000000 00000000			
0xB0A00028	PPU0_PRS11 00000000 00000000 00000000 00000000				PPU0_PRS10 00000000 00000000 00000000 00000000			
0xB0A00030	PPU0_PRS13 00000000 00000000 00000000 00000000				PPU0_PRS12 00000000 00000000 00000000 00000000			
0xB0A00038- B0A00040	reserved XXXXXXXX XXXXXXXX XXXXXXXX XXXXXXXX XXXXXXXX XXXXXXXX XXXXXXXX XXXXXXXX							
0xB0A00048	PPU0_PAS3 00000000 00000000 00000000 00000000				PPU0_PAS2 00000000 00000000 00000000 00000000			
0xB0A00050	PPU0_PAS5 00000000 00000000 00000000 00000000				PPU0_PAS4 00000000 00000000 00000000 00000000			
0xB0A00058	PPU0_PAS7 00000000 00000000 00000000 00000000				PPU0_PAS6 00000000 00000000 00000000 00000000			
0xB0A00060	PPU0_PAS9 00000000 00000000 00000000 00000000				PPU0_PAS8 00000000 00000000 00000000 00000000			
0xB0A00068	PPU0_PAS11 00000000 00000000 00000000 00000000				PPU0_PAS10 00000000 00000000 00000000 00000000			
0xB0A00070	PPU0_PAS13 00000000 00000000 00000000 00000000				PPU0_PAS12 00000000 00000000 00000000 00000000			
0xB0A00078	reserved XXXXXXXX XXXXXXXX XXXXXXXX XXXXXXXX XXXXXXXX XXXXXXXX XXXXXXXX XXXXXXXX							
0xB0A00080	PPU0_GAS1 00000000 00000000 00000000 00000000				PPU0_GAS0 00000000 00000000 00000000 00000000			
0xB0A00088	PPU0_GAS3 00000000 00000000 00000000 00000000				PPU0_GAS2 00000000 00000000 00000000 00000000			
0xB0A00090	PPU0_GAS5 00000000 00000000 00000000 00000000				PPU0_GAS4 00000000 00000000 00000000 00000000			
0xB0A00098- B0A000C0	reserved XXXXXXXX XXXXXXXX XXXXXXXX XXXXXXXX XXXXXXXX XXXXXXXX XXXXXXXX XXXXXXXX							
0xB0A000C8	PPU0_PRC3 00000000 00000000 00000000 00000000				PPU0_PRC2 00000000 00000000 00000000 00000000			
0xB0A000D0	PPU0_PRC5 00000000 00000000 00000000 00000000				PPU0_PRC4 00000000 00000000 00000000 00000000			
0xB0A000D8	PPU0_PRC7 00000000 00000000 00000000 00000000				PPU0_PRC6 00000000 00000000 00000000 00000000			
0xB0A000E0	PPU0_PRC9 00000000 00000000 00000000 00000000				PPU0_PRC8 00000000 00000000 00000000 00000000			
0xB0A000E8	PPU0_PRC11 00000000 00000000 00000000 00000000				PPU0_PRC10 00000000 00000000 00000000 00000000			
0xB0A000F0	PPU0_PRC13 00000000 00000000 00000000 00000000				PPU0_PRC12 00000000 00000000 00000000 00000000			

Table 37. Memory Layout of PERI3_ERBUS Registers with Default Values (Continued)

Offset	+7	+6	+5	+4	+3	+2	+1	+0
0xB0A000F8- B0A00100	reserved XXXXXXXX XXXXXXXX XXXXXXXX XXXXXXXX XXXXXXXX XXXXXXXX XXXXXXXX XXXXXXXX							
0xB0A00108	PPU0_PAC3 00000000 00000000 00000000 00000000				PPU0_PAC2 00000000 00000000 00000000 00000000			
0xB0A00110	PPU0_PAC5 00000000 00000000 00000000 00000000				PPU0_PAC4 00000000 00000000 00000000 00000000			
0xB0A00118	PPU0_PAC7 00000000 00000000 00000000 00000000				PPU0_PAC6 00000000 00000000 00000000 00000000			
0xB0A00120	PPU0_PAC9 00000000 00000000 00000000 00000000				PPU0_PAC8 00000000 00000000 00000000 00000000			
0xB0A00128	PPU0_PAC11 00000000 00000000 00000000 00000000				PPU0_PAC10 00000000 00000000 00000000 00000000			
0xB0A00130	PPU0_PAC13 00000000 00000000 00000000 00000000				PPU0_PAC12 00000000 00000000 00000000 00000000			
0xB0A00138	reserved XXXXXXXX XXXXXXXX XXXXXXXX XXXXXXXX XXXXXXXX XXXXXXXX XXXXXXXX XXXXXXXX							
0xB0A00140	PPU0_GAC1 00000000 00000000 00000000 00000000				PPU0_GAC0 00000000 00000000 00000000 00000000			
0xB0A00148	PPU0_GAC3 00000000 00000000 00000000 00000000				PPU0_GAC2 00000000 00000000 00000000 00000000			
0xB0A00150	PPU0_GAC5 00000000 00000000 00000000 00000000				PPU0_GAC4 00000000 00000000 00000000 00000000			
0xB0A00158- B0A00180	reserved XXXXXXXX XXXXXXXX XXXXXXXX XXXXXXXX XXXXXXXX XXXXXXXX XXXXXXXX XXXXXXXX							
0xB0A00188	PPU0_PR3 00000000 00000000 00000000 00000000				PPU0_PR2 00000000 00000000 00000000 00000000			
0xB0A00190	PPU0_PR5 00000000 00000000 00000000 00000000				PPU0_PR4 00000000 00000000 00000000 00000000			
0xB0A00198	PPU0_PR7 00000000 00000000 00000000 00000000				PPU0_PR6 00000000 00000000 00000000 00000000			
0xB0A001A0	PPU0_PR9 00000000 00000000 00000000 00000000				PPU0_PR8 00000000 00000000 00000000 00000000			
0xB0A001A8	PPU0_PR11 00000000 00000000 00000000 00000000				PPU0_PR10 00000000 00000000 00000000 00000000			
0xB0A001B0	PPU0_PR13 00000000 00000000 00000000 00000000				PPU0_PR12 00000000 00000000 00000000 00000000			
0xB0A001B8- B0A001C0	reserved XXXXXXXX XXXXXXXX XXXXXXXX XXXXXXXX XXXXXXXX XXXXXXXX XXXXXXXX XXXXXXXX							
0xB0A001C8	PPU0_PA3 00000000 00000000 00000000 00000000				PPU0_PA2 00000000 00000000 00000000 00000000			
0xB0A001D0	PPU0_PA5 00000000 00000000 00000000 00000000				PPU0_PA4 00000000 00000000 00000000 00000000			
0xB0A001D8	PPU0_PA7 00000000 00000000 00000000 00000000				PPU0_PA6 00000000 00000000 00000000 00000000			
0xB0A001E0	PPU0_PA9 00000000 00000000 00000000 00000000				PPU0_PA8 00000000 00000000 00000000 00000000			
0xB0A001E8	PPU0_PA11 00000000 00000000 00000000 00000000				PPU0_PA10 00000000 00000000 00000000 00000000			
0xB0A001F0	PPU0_PA13 00000000 00000000 00000000 00000000				PPU0_PA12 00000000 00000000 00000000 00000000			

Table 37. Memory Layout of PERI3_ERBUS Registers with Default Values (Continued)

Offset	+7	+6	+5	+4	+3	+2	+1	+0
0xB0A001F8	reserved XXXXXXXX XXXXXXXX XXXXXXXX XXXXXXXX XXXXXXXX XXXXXXXX XXXXXXXX XXXXXXXX							
0xB0A00200	PPU0_GA1 00000000 00000000 00000000 00000000				PPU0_GA0 00000000 00000000 00000000 00000000			
0xB0A00208	PPU0_GA3 00000000 00000000 00000000 00000000				PPU0_GA2 00000000 00000000 00000000 00000000			
0xB0A00210	PPU0_GA5 00000000 00000000 00000000 00000000				PPU0_GA4 00000000 00000000 00000000 00000000			
0xB0A00218- B0A00238	reserved XXXXXXXX XXXXXXXX XXXXXXXX XXXXXXXX XXXXXXXX XXXXXXXX XXXXXXXX XXXXXXXX							
0xB0A00240	reserved XXXXXXXX XXXXXXXX XXXXXXXX XXXXXXXX				PPU0_UNLOCK 00000000 00000000 00000000 00000000			
0xB0A00248	PPU0_CTR XXXXXXXX 00000001 00000000 00000000				PPU0_ST XXXXXXXX XXXXXXXX 00000001 00000001			
0xB0A00250- B0A07FF8	reserved XXXXXXXX XXXXXXXX XXXXXXXX XXXXXXXX XXXXXXXX XXXXXXXX XXXXXXXX XXXXXXXX							
0xB0A08000	GPIO_POSR0 00000000 00000000 00000000 00000000 00000000 00000000 00000000 00000000							
0xB0A08008	GPIO_POCR0 00000000 00000000 00000000 00000000 00000000 00000000 00000000 00000000							
0xB0A08010	GPIO_DDSR0 00000000 00000000 00000000 00000000 00000000 00000000 00000000 00000000							
0xB0A08018	GPIO_DDCR0 00000000 00000000 00000000 00000000 00000000 00000000 00000000 00000000							
0xB0A08020	GPIO_POSR1 00000000 00000000 00000000 00000000 00000000 00000000 00000000 00000000							
0xB0A08028	GPIO_POCR1 00000000 00000000 00000000 00000000 00000000 00000000 00000000 00000000							
0xB0A08030	GPIO_DDSR1 00000000 00000000 00000000 00000000 00000000 00000000 00000000 00000000							
0xB0A08038	GPIO_DDCR1 00000000 00000000 00000000 00000000 00000000 00000000 00000000 00000000							
0xB0A08040	GPIO_POSR2 00000000 00000000 00000000 00000000 00000000 00000000 00000000 00000000							
0xB0A08048	GPIO_POCR2 00000000 00000000 00000000 00000000 00000000 00000000 00000000 00000000							
0xB0A08050	GPIO_DDSR2 00000000 00000000 00000000 00000000 00000000 00000000 00000000 00000000							
0xB0A08058	GPIO_DDCR2 00000000 00000000 00000000 00000000 00000000 00000000 00000000 00000000							
0xB0A08060	GPIO_POSR3 00000000 00000000 00000000 00000000 00000000 00000000 00000000 00000000							
0xB0A08068	GPIO_POCR3 00000000 00000000 00000000 00000000 00000000 00000000 00000000 00000000							
0xB0A08070	GPIO_DDSR3 00000000 00000000 00000000 00000000 00000000 00000000 00000000 00000000							
0xB0A08078	GPIO_DDCR3 00000000 00000000 00000000 00000000 00000000 00000000 00000000 00000000							
0xB0A08080- B0A081F8	reserved 00000000 00000000 00000000 00000000 00000000 00000000 00000000 00000000							
0xB0A08200	GPIO_PODR0 00000000 00000000 00000000 00000000 00000000 00000000 00000000 00000000							

Table 37. Memory Layout of PERI3_ERBUS Registers with Default Values (Continued)

Offset	+7	+6	+5	+4	+3	+2	+1	+0
0xB0A08208	GPIO_DDR0 00000000 00000000 00000000 00000000 00000000 00000000 00000000 00000000							
0xB0A08210	GPIO_PODR1 00000000 00000000 00000000 00000000 00000000 00000000 00000000 00000000							
0xB0A08218	GPIO_DDR1 00000000 00000000 00000000 00000000 00000000 00000000 00000000 00000000							
0xB0A08220	GPIO_PODR2 00000000 00000000 00000000 00000000 00000000 00000000 00000000 00000000							
0xB0A08228	GPIO_DDR2 00000000 00000000 00000000 00000000 00000000 00000000 00000000 00000000							
0xB0A08230	GPIO_PODR3 00000000 00000000 00000000 00000000 00000000 00000000 00000000 00000000							
0xB0A08238	GPIO_DDR3 00000000 00000000 00000000 00000000 00000000 00000000 00000000 00000000							
0xB0A08240- B0A082F8	reserved 00000000 00000000 00000000 00000000 00000000 00000000 00000000 00000000							
0xB0A08300	GPIO_PIDR0 XXXXXXXX XXXXXXXX XXXXXXXX XXXXXXXX XXXXXXXX XXXXXXXX XXXXXXXX XXXXXXXX							
0xB0A08308	GPIO_PIDR1 XXXXXXXX XXXXXXXX XXXXXXXX XXXXXXXX XXXXXXXX XXXXXXXX XXXXXXXX XXXXXXXX							
0xB0A08310	GPIO_PIDR2 XXXXXXXX XXXXXXXX XXXXXXXX XXXXXXXX XXXXXXXX XXXXXXXX XXXXXXXX XXXXXXXX							
0xB0A08318	GPIO_PIDR3 XXXXXXXX XXXXXXXX XXXXXXXX XXXXXXXX XXXXXXXX XXXXXXXX XXXXXXXX XXXXXXXX							
0xB0A08320- B0A08378	reserved XXXXXXXX XXXXXXXX XXXXXXXX XXXXXXXX XXXXXXXX XXXXXXXX XXXXXXXX XXXXXXXX							
0xB0A08380	GPIO_PPER0 00000000 00000000 00000000 00000000 00000000 00000000 00000000 00000000							
0xB0A08388	GPIO_PPER1 00000000 00000000 00000000 00000000 00000000 00000000 00000000 00000000							
0xB0A08390	GPIO_PPER2 00000000 00000000 00000000 00000000 00000000 00000000 00000000 00000000							
0xB0A08398	GPIO_PPER3 00000000 00000000 00000000 00000000 00000000 00000000 00000000 00000000							
0xB0A083A0- B0A0FF8	reserved XXXXXXXX XXXXXXXX XXXXXXXX XXXXXXXX XXXXXXXX XXXXXXXX XXXXXXXX XXXXXXXX							
0xB0A10000	reserved XXXXXXXX XXXXXXXX XXXXXXXX XXXXXXXX				RLT0_DMCFG XXXXXXXX XXXXXXXX XXXXXXXX 00000000			
0xB0A10008	reserved XXXXXXXX XXXXXXXX XXXXXXXX XXXXXXXX				RLT0_TMCSR 00000000 00000000 00000000 00000000			
0xB0A10010	RLT0_TMR XXXXXXXX XXXXXXXX XXXXXXXX XXXXXXXX				RLT0_TMRLR XXXXXXXX XXXXXXXX XXXXXXXX XXXXXXXX			
0xB0A10018- B0A103F8	reserved XXXXXXXX XXXXXXXX XXXXXXXX XXXXXXXX XXXXXXXX XXXXXXXX XXXXXXXX XXXXXXXX							
0xB0A10400	reserved XXXXXXXX XXXXXXXX XXXXXXXX XXXXXXXX				RLT1_DMCFG XXXXXXXX XXXXXXXX XXXXXXXX 00000000			
0xB0A10408	reserved XXXXXXXX XXXXXXXX XXXXXXXX XXXXXXXX				RLT1_TMCSR 00000000 00000000 00000000 00000000			
0xB0A10410	RLT1_TMR XXXXXXXX XXXXXXXX XXXXXXXX XXXXXXXX				RLT1_TMRLR XXXXXXXX XXXXXXXX XXXXXXXX XXXXXXXX			
0xB0A10418- B0A107F8	reserved XXXXXXXX XXXXXXXX XXXXXXXX XXXXXXXX XXXXXXXX XXXXXXXX XXXXXXXX XXXXXXXX							

Table 37. Memory Layout of PERI3_ERBUS Registers with Default Values (Continued)

Offset	+7	+6	+5	+4	+3	+2	+1	+0
0xB0A10800	reserved XXXXXXXX XXXXXXXX XXXXXXXX XXXXXXXX				RLT2_DMACFG XXXXXXXX XXXXXXXX XXXXXXXX 00000000			
0xB0A10808	reserved XXXXXXXX XXXXXXXX XXXXXXXX XXXXXXXX				RLT2_TMCSR 00000000 00000000 00000000 00000000			
0xB0A10810	RLT2_TMR XXXXXXXX XXXXXXXX XXXXXXXX XXXXXXXX				RLT2_TMRLR XXXXXXXX XXXXXXXX XXXXXXXX XXXXXXXX			
0xB0A10818- B0A10BF8	reserved XXXXXXXX XXXXXXXX XXXXXXXX XXXXXXXX XXXXXXXX XXXXXXXX XXXXXXXX XXXXXXXX							
0xB0A10C00	reserved XXXXXXXX XXXXXXXX XXXXXXXX XXXXXXXX				RLT3_DMACFG XXXXXXXX XXXXXXXX XXXXXXXX 00000000			
0xB0A10C08	reserved XXXXXXXX XXXXXXXX XXXXXXXX XXXXXXXX				RLT3_TMCSR 00000000 00000000 00000000 00000000			
0xB0A10C10	RLT3_TMR XXXXXXXX XXXXXXXX XXXXXXXX XXXXXXXX				RLT3_TMRLR XXXXXXXX XXXXXXXX XXXXXXXX XXXXXXXX			
0xB0A10C18- B0A10FF8	reserved XXXXXXXX XXXXXXXX XXXXXXXX XXXXXXXX XXXXXXXX XXXXXXXX XXXXXXXX XXXXXXXX							
0xB0A11000	reserved XXXXXXXX XXXXXXXX XXXXXXXX XXXXXXXX				RLT4_DMACFG XXXXXXXX XXXXXXXX XXXXXXXX 00000000			
0xB0A11008	reserved XXXXXXXX XXXXXXXX XXXXXXXX XXXXXXXX				RLT4_TMCSR 00000000 00000000 00000000 00000000			
0xB0A11010	RLT4_TMR XXXXXXXX XXXXXXXX XXXXXXXX XXXXXXXX				RLT4_TMRLR XXXXXXXX XXXXXXXX XXXXXXXX XXXXXXXX			
0xB0A11018- B0A113F8	reserved XXXXXXXX XXXXXXXX XXXXXXXX XXXXXXXX XXXXXXXX XXXXXXXX XXXXXXXX XXXXXXXX							
0xB0A11400	reserved XXXXXXXX XXXXXXXX XXXXXXXX XXXXXXXX				RLT5_DMACFG XXXXXXXX XXXXXXXX XXXXXXXX 00000000			
0xB0A11408	reserved XXXXXXXX XXXXXXXX XXXXXXXX XXXXXXXX				RLT5_TMCSR 00000000 00000000 00000000 00000000			
0xB0A11410	RLT5_TMR XXXXXXXX XXXXXXXX XXXXXXXX XXXXXXXX				RLT5_TMRLR XXXXXXXX XXXXXXXX XXXXXXXX XXXXXXXX			
0xB0A11418- B0A117F8	reserved XXXXXXXX XXXXXXXX XXXXXXXX XXXXXXXX XXXXXXXX XXXXXXXX XXXXXXXX XXXXXXXX							
0xB0A11800	reserved XXXXXXXX XXXXXXXX XXXXXXXX XXXXXXXX				RLT6_DMACFG XXXXXXXX XXXXXXXX XXXXXXXX 00000000			
0xB0A11808	reserved XXXXXXXX XXXXXXXX XXXXXXXX XXXXXXXX				RLT6_TMCSR 00000000 00000000 00000000 00000000			
0xB0A11810	RLT6_TMR XXXXXXXX XXXXXXXX XXXXXXXX XXXXXXXX				RLT6_TMRLR XXXXXXXX XXXXXXXX XXXXXXXX XXXXXXXX			
0xB0A11818- B0A11BF8	reserved XXXXXXXX XXXXXXXX XXXXXXXX XXXXXXXX XXXXXXXX XXXXXXXX XXXXXXXX XXXXXXXX							
0xB0A11C00	reserved XXXXXXXX XXXXXXXX XXXXXXXX XXXXXXXX				RLT7_DMACFG XXXXXXXX XXXXXXXX XXXXXXXX 00000000			
0xB0A11C08	reserved XXXXXXXX XXXXXXXX XXXXXXXX XXXXXXXX				RLT7_TMCSR 00000000 00000000 00000000 00000000			
0xB0A11C10	RLT7_TMR XXXXXXXX XXXXXXXX XXXXXXXX XXXXXXXX				RLT7_TMRLR XXXXXXXX XXXXXXXX XXXXXXXX XXXXXXXX			
0xB0A11C18- B0A11FF8	reserved XXXXXXXX XXXXXXXX XXXXXXXX XXXXXXXX XXXXXXXX XXXXXXXX XXXXXXXX XXXXXXXX							
0xB0A12000	reserved XXXXXXXX XXXXXXXX XXXXXXXX XXXXXXXX				RLT8_DMACFG XXXXXXXX XXXXXXXX XXXXXXXX 00000000			

Table 37. Memory Layout of PERI3_ERBUS Registers with Default Values (Continued)

Offset	+7	+6	+5	+4	+3	+2	+1	+0
0xB0A12008	reserved XXXXXXXX XXXXXXXX XXXXXXXX XXXXXXXX				RLT8_TMCSR 00000000 00000000 00000000 00000000			
0xB0A12010	RLT8_TMR XXXXXXXX XXXXXXXX XXXXXXXX XXXXXXXX				RLT8_TMLR XXXXXXXX XXXXXXXX XXXXXXXX XXXXXXXX			
0xB0A12018- B0A123F8	reserved XXXXXXXX XXXXXXXX XXXXXXXX XXXXXXXX XXXXXXXX XXXXXXXX XXXXXXXX XXXXXXXX							
0xB0A12400	reserved XXXXXXXX XXXXXXXX XXXXXXXX XXXXXXXX				RLT9_DMACFG XXXXXXXX XXXXXXXX XXXXXXXX 00000000			
0xB0A12408	reserved XXXXXXXX XXXXXXXX XXXXXXXX XXXXXXXX				RLT9_TMCSR 00000000 00000000 00000000 00000000			
0xB0A12410	RLT9_TMR XXXXXXXX XXXXXXXX XXXXXXXX XXXXXXXX				RLT9_TMLR XXXXXXXX XXXXXXXX XXXXXXXX XXXXXXXX			
0xB0A12418- B0A1FFF8	reserved XXXXXXXX XXXXXXXX XXXXXXXX XXXXXXXX XXXXXXXX XXXXXXXX XXXXXXXX XXXXXXXX							
0xB0A20000	UDC0_ECC1 XXXXXXXX 00000000		UDC0_CC1 00000000 00000000		UDC0_ECC0 XXXXXXXX 00000000		UDC0_CC0 00000000 00000000	
0xB0A20008	UDC0_TGL1 00000000 00000000		UDC0_TGL0 00000000 00000000		UDC0_CS1 00000000 00000000		UDC0_CS0 00000000 00000000	
0xB0A20010	UDC0_RC 00000000 00000000 00000000 00000000				UDC0_CR 00000000 00000000 00000000 00000000			
0xB0A20018	reserved XXXXXXXX XXXXXXXX XXXXXXXX XXXXXXXX				reserved XXXXXXXX XXXXXXXX		UDC0_DBG XXXXXXXX 00000000	
0xB0A20020- B0AEFFF8	reserved XXXXXXXX XXXXXXXX XXXXXXXX XXXXXXXX XXXXXXXX XXXXXXXX XXXXXXXX XXXXXXXX							
0xB0AF0000	BEUC3_ADDRH 00000000 00000000		BEUC3_ADDRL 00000000 00000000		BEUC3_CTRH 00000000 00000000		BEUC3_CTRL 00000000 00000000	
0xB0AF0008	BEUC3_DATAHH 00000000 00000000		BEUC3_DATAHL 00000000 00000000		BEUC3_DATA LH 00000000 00000000		BEUC3_DATALL 00000000 00000000	
0xB0AF0010	reserved 00000000 00000000		BEUC3_MIDH XXXXXXXX XXXXXXXX		BEUC3_MIDL XXXXXXXX XXXXXXXX		BEUC3_MASTERID 00000000 00000000	
0xB0AF0018	reserved 00000000 00000000		reserved 00000000 00000000		reserved 00000000 00000000		BEUC3_NMIEN XXXXXXXX 00000001	
0xB0AF0020- B0AF87F8	reserved XXXXXXXX XXXXXXXX XXXXXXXX XXXXXXXX XXXXXXXX XXXXXXXX XXXXXXXX XXXXXXXX							
0xB0AF8800	reserved XXXXXXXX XXXXXXXX		reserved XXXXXXXX XXXXXXXX		reserved XXXXXXXX XXXXXXXX		RICFG3_RLT0TIN 00000000 00000000	
0xB0AF8808- B0AF8818	reserved XXXXXXXX XXXXXXXX XXXXXXXX XXXXXXXX XXXXXXXX XXXXXXXX XXXXXXXX XXXXXXXX							
0xB0AF8820	reserved XXXXXXXX XXXXXXXX		reserved XXXXXXXX XXXXXXXX		reserved XXXXXXXX XXXXXXXX		RICFG3_RLT1TIN 00000000 00000000	
0xB0AF8828- B0AF8838	reserved XXXXXXXX XXXXXXXX XXXXXXXX XXXXXXXX XXXXXXXX XXXXXXXX XXXXXXXX XXXXXXXX							
0xB0AF8840	reserved XXXXXXXX XXXXXXXX		reserved XXXXXXXX XXXXXXXX		reserved XXXXXXXX XXXXXXXX		RICFG3_RLT2TIN 00000000 00000000	
0xB0AF8848- B0AF8858	reserved XXXXXXXX XXXXXXXX XXXXXXXX XXXXXXXX XXXXXXXX XXXXXXXX XXXXXXXX XXXXXXXX							
0xB0AF8860	reserved XXXXXXXX XXXXXXXX		reserved XXXXXXXX XXXXXXXX		reserved XXXXXXXX XXXXXXXX		RICFG3_RLT3TIN 00000000 00000000	
0xB0AF8868- B0AF8878	reserved XXXXXXXX XXXXXXXX XXXXXXXX XXXXXXXX XXXXXXXX XXXXXXXX XXXXXXXX XXXXXXXX							
0xB0AF8880	reserved XXXXXXXX XXXXXXXX		reserved XXXXXXXX XXXXXXXX		reserved XXXXXXXX XXXXXXXX		RICFG3_RLT4TIN 00000000 00000000	

Table 38. Memory Layout of PERI4_SLAVE Registers with Default Values

Offset	+3	+2	+1	+0
0xB0B00000		MPUXGFX_CTRL0 00000000 00000000 00000001 00000000		
0xB0B00004		MPUXGFX_NMIEN 00000000 00000000 00000000 00000001		
0xB0B00008		MPUXGFX_WERRC 00000000 00000000 0000XXXX XXXXXXXX		
0xB0B0000C		MPUXGFX_WERRA XXXXXXXX XXXXXXXX XXXXXXXX XXXXXXXX		
0xB0B00010		MPUXGFX_RERRC 00000000 00000000 0000XXXX XXXXXXXX		
0xB0B00014		MPUXGFX_RERRA XXXXXXXX XXXXXXXX XXXXXXXX XXXXXXXX		
0xB0B00018		MPUXGFX_CTRL1 00000000 00000000 00000000 00000000		
0xB0B0001C		MPUXGFX_SADDR1 00000000 00000000 00000000 00000000		
0xB0B00020		MPUXGFX_EADDR1 00000000 00000000 00000000 01111111		
0xB0B00024		MPUXGFX_CTRL2 00000000 00000000 00000000 00000000		
0xB0B00028		MPUXGFX_SADDR2 00000000 00000000 00000000 00000000		
0xB0B0002C		MPUXGFX_EADDR2 00000000 00000000 00000000 01111111		
0xB0B00030		MPUXGFX_CTRL3 00000000 00000000 00000000 00000000		
0xB0B00034		MPUXGFX_SADDR3 00000000 00000000 00000000 00000000		
0xB0B00038		MPUXGFX_EADDR3 00000000 00000000 00000000 01111111		
0xB0B0003C		MPUXGFX_CTRL4 00000000 00000000 00000000 00000000		
0xB0B00040		MPUXGFX_SADDR4 00000000 00000000 00000000 00000000		
0xB0B00044		MPUXGFX_EADDR4 00000000 00000000 00000000 01111111		
0xB0B00048		MPUXGFX_CTRL5 00000000 00000000 00000000 00000000		
0xB0B0004C		MPUXGFX_SADDR5 00000000 00000000 00000000 00000000		
0xB0B00050		MPUXGFX_EADDR5 00000000 00000000 00000000 01111111		
0xB0B00054		MPUXGFX_CTRL6 00000000 00000000 00000000 00000000		
0xB0B00058		MPUXGFX_SADDR6 00000000 00000000 00000000 00000000		
0xB0B0005C		MPUXGFX_EADDR6 00000000 00000000 00000000 01111111		
0xB0B00060		MPUXGFX_CTRL7 00000000 00000000 00000000 00000000		
0xB0B00064		MPUXGFX_SADDR7 00000000 00000000 00000000 00000000		

Table 38. Memory Layout of PERI4_SLAVE Registers with Default Values (Continued)

Offset	+3	+2	+1	+0
0xB0B00068	MPUXGFX_EADDR7 00000000 00000000 00000000 01111111			
0xB0B0006C	MPUXGFX_CTRL8 00000000 00000000 00000000 00000000			
0xB0B00070	MPUXGFX_SADDR8 00000000 00000000 00000000 00000000			
0xB0B00074	MPUXGFX_EADDR8 00000000 00000000 00000000 01111111			
0xB0B00078	MPUXGFX_UNLOCK 00000000 00000000 00000000 00000000			
0xB0B0007C	MPUXGFX_MID 00000000 00000000 00000000 00000000			
0xB0B00080- B0B1FFFC	reserved XXXXXXXX XXXXXXXX XXXXXXXX XXXXXXXX			
0xB0B20000	I2S0_RXFDAT0 00000000 00000000 00000000 00000000			
0xB0B20004	I2S0_RXFDAT1 00000000 00000000 00000000 00000000			
0xB0B20008	I2S0_RXFDAT2 00000000 00000000 00000000 00000000			
0xB0B2000C	I2S0_RXFDAT3 00000000 00000000 00000000 00000000			
0xB0B20010	I2S0_RXFDAT4 00000000 00000000 00000000 00000000			
0xB0B20014	I2S0_RXFDAT5 00000000 00000000 00000000 00000000			
0xB0B20018	I2S0_RXFDAT6 00000000 00000000 00000000 00000000			
0xB0B2001C	I2S0_RXFDAT7 00000000 00000000 00000000 00000000			
0xB0B20020	I2S0_RXFDAT8 00000000 00000000 00000000 00000000			
0xB0B20024	I2S0_RXFDAT9 00000000 00000000 00000000 00000000			
0xB0B20028	I2S0_RXFDAT10 00000000 00000000 00000000 00000000			
0xB0B2002C	I2S0_RXFDAT11 00000000 00000000 00000000 00000000			
0xB0B20030	I2S0_RXFDAT12 00000000 00000000 00000000 00000000			
0xB0B20034	I2S0_RXFDAT13 00000000 00000000 00000000 00000000			
0xB0B20038	I2S0_RXFDAT14 00000000 00000000 00000000 00000000			
0xB0B2003C	I2S0_RXFDAT15 00000000 00000000 00000000 00000000			
0xB0B20040	I2S0_TXFDAT0 00000000 00000000 00000000 00000000			
0xB0B20044	I2S0_TXFDAT1 00000000 00000000 00000000 00000000			
0xB0B20048	I2S0_TXFDAT2 00000000 00000000 00000000 00000000			

Table 38. Memory Layout of PERI4_SLAVE Registers with Default Values (Continued)

Offset	+3	+2	+1	+0
0xB0B2004C		I2S0_TXFDAT3 00000000 00000000 00000000 00000000		
0xB0B20050		I2S0_TXFDAT4 00000000 00000000 00000000 00000000		
0xB0B20054		I2S0_TXFDAT5 00000000 00000000 00000000 00000000		
0xB0B20058		I2S0_TXFDAT6 00000000 00000000 00000000 00000000		
0xB0B2005C		I2S0_TXFDAT7 00000000 00000000 00000000 00000000		
0xB0B20060		I2S0_TXFDAT8 00000000 00000000 00000000 00000000		
0xB0B20064		I2S0_TXFDAT9 00000000 00000000 00000000 00000000		
0xB0B20068		I2S0_TXFDAT10 00000000 00000000 00000000 00000000		
0xB0B2006C		I2S0_TXFDAT11 00000000 00000000 00000000 00000000		
0xB0B20070		I2S0_TXFDAT12 00000000 00000000 00000000 00000000		
0xB0B20074		I2S0_TXFDAT13 00000000 00000000 00000000 00000000		
0xB0B20078		I2S0_TXFDAT14 00000000 00000000 00000000 00000000		
0xB0B2007C		I2S0_TXFDAT15 00000000 00000000 00000000 00000000		
0xB0B20080		I2S0_CNTREG 00000000 00000000 00000000 01100000		
0xB0B20084		I2S0_MCR0REG 00000000 00000000 00000000 00000000		
0xB0B20088		I2S0_MCR1REG 00000000 00000000 00000000 00000000		
0xB0B2008C		I2S0_MCR2REG 00000000 00000000 00000000 00000000		
0xB0B20090		I2S0_OPRREG 00000000 00000000 00000000 00000000		
0xB0B20094		I2S0_SRST 00000000 00000000 00000000 00000000		
0xB0B20098		I2S0_INTCNT 01111111 00111111 00000000 00000000		
0xB0B2009C		I2S0_STATUS 00000000 00000000 00000000 00000000		
0xB0B200A0		I2S0_DMAACT 00000000 00000000 00000000 00000000		
0xB0B200A4		I2S0_DEBUG 00000000 00000000 00000000 00000000		
0xB0B200A8		I2S0_MIDREG 00000000 00000000 00000000 00000000		
0xB0B200AC- B0B203FC		reserved XXXXXXXX XXXXXXXX XXXXXXXX XXXXXXXX		
0xB0B20400		I2S1_RXFDAT0 00000000 00000000 00000000 00000000		

Table 38. Memory Layout of PERI4_SLAVE Registers with Default Values (Continued)

Offset	+3	+2	+1	+0
0xB0B20404		I2S1_RXFDAT1 00000000 00000000 00000000 00000000		
0xB0B20408		I2S1_RXFDAT2 00000000 00000000 00000000 00000000		
0xB0B2040C		I2S1_RXFDAT3 00000000 00000000 00000000 00000000		
0xB0B20410		I2S1_RXFDAT4 00000000 00000000 00000000 00000000		
0xB0B20414		I2S1_RXFDAT5 00000000 00000000 00000000 00000000		
0xB0B20418		I2S1_RXFDAT6 00000000 00000000 00000000 00000000		
0xB0B2041C		I2S1_RXFDAT7 00000000 00000000 00000000 00000000		
0xB0B20420		I2S1_RXFDAT8 00000000 00000000 00000000 00000000		
0xB0B20424		I2S1_RXFDAT9 00000000 00000000 00000000 00000000		
0xB0B20428		I2S1_RXFDAT10 00000000 00000000 00000000 00000000		
0xB0B2042C		I2S1_RXFDAT11 00000000 00000000 00000000 00000000		
0xB0B20430		I2S1_RXFDAT12 00000000 00000000 00000000 00000000		
0xB0B20434		I2S1_RXFDAT13 00000000 00000000 00000000 00000000		
0xB0B20438		I2S1_RXFDAT14 00000000 00000000 00000000 00000000		
0xB0B2043C		I2S1_RXFDAT15 00000000 00000000 00000000 00000000		
0xB0B20440		I2S1_TXFDAT0 00000000 00000000 00000000 00000000		
0xB0B20444		I2S1_TXFDAT1 00000000 00000000 00000000 00000000		
0xB0B20448		I2S1_TXFDAT2 00000000 00000000 00000000 00000000		
0xB0B2044C		I2S1_TXFDAT3 00000000 00000000 00000000 00000000		
0xB0B20450		I2S1_TXFDAT4 00000000 00000000 00000000 00000000		
0xB0B20454		I2S1_TXFDAT5 00000000 00000000 00000000 00000000		
0xB0B20458		I2S1_TXFDAT6 00000000 00000000 00000000 00000000		
0xB0B2045C		I2S1_TXFDAT7 00000000 00000000 00000000 00000000		
0xB0B20460		I2S1_TXFDAT8 00000000 00000000 00000000 00000000		
0xB0B20464		I2S1_TXFDAT9 00000000 00000000 00000000 00000000		
0xB0B20468		I2S1_TXFDAT10 00000000 00000000 00000000 00000000		

Table 38. Memory Layout of PERI4_SLAVE Registers with Default Values (Continued)

Offset	+3	+2	+1	+0
0xB0B2046C		I2S1_TXFDAT11 00000000 00000000 00000000 00000000		
0xB0B20470		I2S1_TXFDAT12 00000000 00000000 00000000 00000000		
0xB0B20474		I2S1_TXFDAT13 00000000 00000000 00000000 00000000		
0xB0B20478		I2S1_TXFDAT14 00000000 00000000 00000000 00000000		
0xB0B2047C		I2S1_TXFDAT15 00000000 00000000 00000000 00000000		
0xB0B20480		I2S1_CNTREG 00000000 00000000 00000000 01100000		
0xB0B20484		I2S1_MCR0REG 00000000 00000000 00000000 00000000		
0xB0B20488		I2S1_MCR1REG 00000000 00000000 00000000 00000000		
0xB0B2048C		I2S1_MCR2REG 00000000 00000000 00000000 00000000		
0xB0B20490		I2S1_OPRREG 00000000 00000000 00000000 00000000		
0xB0B20494		I2S1_SRST 00000000 00000000 00000000 00000000		
0xB0B20498		I2S1_INTCNT 01111111 00111111 00000000 00000000		
0xB0B2049C		I2S1_STATUS 00000000 00000000 00000000 00000000		
0xB0B204A0		I2S1_DMAACT 00000000 00000000 00000000 00000000		
0xB0B204A4		I2S1_DEBUG 00000000 00000000 00000000 00000000		
0xB0B204A8		I2S1_MIDREG 00000000 00000000 00000000 00000000		
0xB0B204AC- B0B2FFFC		reserved XXXXXXXX XXXXXXXX XXXXXXXX XXXXXXXX		
0xB0B30000		CRC0_POLY 00000100 11000001 00011101 10110111		
0xB0B30004		CRC0_SEED 11111111 11111111 11111111 11111111		
0xB0B30008		CRC0_FXOR 11111111 11111111 11111111 11111111		
0xB0B3000C		CRC0_CFG 00000000 11100000 00000000 00000000		
0xB0B30010		CRC0_WR 00000000 00000000 00000000 00000000		
0xB0B30014		CRC0_RD 00000000 00000000 00000000 00000000		
0xB0B30018- B0B37FFC		reserved XXXXXXXX XXXXXXXX XXXXXXXX XXXXXXXX		
0xB0B38000		SPI0_MCTRL 00000000 00000000 00000000 00000000		
0xB0B38004		SPI0_PCC0 00000000 00000001 00000000 00000000		

Table 38. Memory Layout of PERI4_SLAVE Registers with Default Values (Continued)

Offset	+3	+2	+1	+0
0xB0B38008	SPI0_PCC1 00000000 00000001 00000000 00000000			
0xB0B3800C	SPI0_PCC2 00000000 00000001 00000000 00000000			
0xB0B38010	SPI0_PCC3 00000000 00000001 00000000 00000000			
0xB0B38014	SPI0_TXF 00000000 00000000 00000000 00000000			
0xB0B38018	SPI0_TXE 00000000 00000000 00000000 00000000			
0xB0B3801C	SPI0_TXC 00000000 00000000 00000000 00000000			
0xB0B38020	SPI0_RXF 00000000 00000000 00000000 00000000			
0xB0B38024	SPI0_RXE 00000000 00000000 00000000 00000000			
0xB0B38028	SPI0_RXC 00000000 00000000 00000000 00000000			
0xB0B3802C	SPI0_FAULTF 00000000 00000000 00000000 00000000			
0xB0B38030	SPI0_FAULTC 00000000 00000000 00000000 00000000			
0xB0B38034	read0 00000000 00000000		SPI0_DMDMAEN 00000000	SPI0_DMCFG 00000001
0xB0B38038	SPI0_DMTRP 00000000	SPI0_DMPSEL 00000000	SPI0_DMSTOP 00000000	SPI0_DMSTART 00000000
0xB0B3803C	SPI0_DMBCS 00000000 00000000		SPI0_DMBCB 00000000 00000000	
0xB0B38040	SPI0_DMSTATUS 00000000 00000000 00000000 00000000			
0xB0B38044	read0 00000000 00000000		SPI0_RXBITCNT 00000000	SPI0_TXBITCNT 00000000
0xB0B38048	SPI0_RXSHIFT 00000000 00000000 00000000 00000000			
0xB0B3804C	SPI0_FIFOCFG 00000000 00000000 00000000 01110111			
0xB0B38050	SPI0_TXFIFO0 00000000 00000000 00000000 00000000			
0xB0B38054	SPI0_TXFIFO1 00000000 00000000 00000000 00000000			
0xB0B38058	SPI0_TXFIFO2 00000000 00000000 00000000 00000000			
0xB0B3805C	SPI0_TXFIFO3 00000000 00000000 00000000 00000000			
0xB0B38060	SPI0_TXFIFO4 00000000 00000000 00000000 00000000			
0xB0B38064	SPI0_TXFIFO5 00000000 00000000 00000000 00000000			
0xB0B38068	SPI0_TXFIFO6 00000000 00000000 00000000 00000000			
0xB0B3806C	SPI0_TXFIFO7 00000000 00000000 00000000 00000000			

Table 38. Memory Layout of PERI4_SLAVE Registers with Default Values (Continued)

Offset	+3	+2	+1	+0
0xB0B38070	SPI0_TXFIFO8 00000000 00000000 00000000 00000000			
0xB0B38074	SPI0_TXFIFO9 00000000 00000000 00000000 00000000			
0xB0B38078	SPI0_TXFIFO10 00000000 00000000 00000000 00000000			
0xB0B3807C	SPI0_TXFIFO11 00000000 00000000 00000000 00000000			
0xB0B38080	SPI0_TXFIFO12 00000000 00000000 00000000 00000000			
0xB0B38084	SPI0_TXFIFO13 00000000 00000000 00000000 00000000			
0xB0B38088	SPI0_TXFIFO14 00000000 00000000 00000000 00000000			
0xB0B3808C	SPI0_TXFIFO15 00000000 00000000 00000000 00000000			
0xB0B38090	SPI0_RXFIFO0 00000000 00000000 00000000 00000000			
0xB0B38094	SPI0_RXFIFO1 00000000 00000000 00000000 00000000			
0xB0B38098	SPI0_RXFIFO2 00000000 00000000 00000000 00000000			
0xB0B3809C	SPI0_RXFIFO3 00000000 00000000 00000000 00000000			
0xB0B380A0	SPI0_RXFIFO4 00000000 00000000 00000000 00000000			
0xB0B380A4	SPI0_RXFIFO5 00000000 00000000 00000000 00000000			
0xB0B380A8	SPI0_RXFIFO6 00000000 00000000 00000000 00000000			
0xB0B380AC	SPI0_RXFIFO7 00000000 00000000 00000000 00000000			
0xB0B380B0	SPI0_RXFIFO8 00000000 00000000 00000000 00000000			
0xB0B380B4	SPI0_RXFIFO9 00000000 00000000 00000000 00000000			
0xB0B380B8	SPI0_RXFIFO10 00000000 00000000 00000000 00000000			
0xB0B380BC	SPI0_RXFIFO11 00000000 00000000 00000000 00000000			
0xB0B380C0	SPI0_RXFIFO12 00000000 00000000 00000000 00000000			
0xB0B380C4	SPI0_RXFIFO13 00000000 00000000 00000000 00000000			
0xB0B380C8	SPI0_RXFIFO14 00000000 00000000 00000000 00000000			
0xB0B380CC	SPI0_RXFIFO15 00000000 00000000 00000000 00000000			
0xB0B380D0- B0B380F8	reserved 00000000 00000000 00000000 00000000			
0xB0B380FC	SPI0_MID 00000000 00000000 00000000 00000001			

Table 38. Memory Layout of PERI4_SLAVE Registers with Default Values (Continued)

Offset	+3	+2	+1	+0
0xB0B38100- B0B383FC	reserved XXXXXXXX XXXXXXXX XXXXXXXX XXXXXXXX			
0xB0B38400	SPI1_MCTRL 00000000 00000000 00000000 00000000			
0xB0B38404	SPI1_PCC0 00000000 00000001 00000000 00000000			
0xB0B38408	SPI1_PCC1 00000000 00000001 00000000 00000000			
0xB0B3840C	SPI1_PCC2 00000000 00000001 00000000 00000000			
0xB0B38410	SPI1_PCC3 00000000 00000001 00000000 00000000			
0xB0B38414	SPI1_TXF 00000000 00000000 00000000 00000000			
0xB0B38418	SPI1_TXE 00000000 00000000 00000000 00000000			
0xB0B3841C	SPI1_TXC 00000000 00000000 00000000 00000000			
0xB0B38420	SPI1_RXF 00000000 00000000 00000000 00000000			
0xB0B38424	SPI1_RXE 00000000 00000000 00000000 00000000			
0xB0B38428	SPI1_RXC 00000000 00000000 00000000 00000000			
0xB0B3842C	SPI1_FAULTF 00000000 00000000 00000000 00000000			
0xB0B38430	SPI1_FAULTC 00000000 00000000 00000000 00000000			
0xB0B38434	read0 00000000 00000000		SPI1_DMDMAEN 00000000	SPI1_DMCFG 00000001
0xB0B38438	SPI1_DMTRP 00000000	SPI1_DMPSEL 00000000	SPI1_DMSTOP 00000000	SPI1_DMSTART 00000000
0xB0B3843C	SPI1_DMBCS 00000000 00000000		SPI1_DMBCB 00000000 00000000	
0xB0B38440	SPI1_DMSTATUS 00000000 00000000 00000000 00000000			
0xB0B38444	read0 00000000 00000000		SPI1_RXBITCNT 00000000	SPI1_TXBITCNT 00000000
0xB0B38448	SPI1_RXSHIFT 00000000 00000000 00000000 00000000			
0xB0B3844C	SPI1_FIFOCFG 00000000 00000000 00000000 01110111			
0xB0B38450	SPI1_TXFIFO0 00000000 00000000 00000000 00000000			
0xB0B38454	SPI1_TXFIFO1 00000000 00000000 00000000 00000000			
0xB0B38458	SPI1_TXFIFO2 00000000 00000000 00000000 00000000			
0xB0B3845C	SPI1_TXFIFO3 00000000 00000000 00000000 00000000			
0xB0B38460	SPI1_TXFIFO4 00000000 00000000 00000000 00000000			

Table 38. Memory Layout of PERI4_SLAVE Registers with Default Values (Continued)

Offset	+3	+2	+1	+0
0xB0B38464		SPI1_TXFIFO5 00000000 00000000 00000000 00000000		
0xB0B38468		SPI1_TXFIFO6 00000000 00000000 00000000 00000000		
0xB0B3846C		SPI1_TXFIFO7 00000000 00000000 00000000 00000000		
0xB0B38470		SPI1_TXFIFO8 00000000 00000000 00000000 00000000		
0xB0B38474		SPI1_TXFIFO9 00000000 00000000 00000000 00000000		
0xB0B38478		SPI1_TXFIFO10 00000000 00000000 00000000 00000000		
0xB0B3847C		SPI1_TXFIFO11 00000000 00000000 00000000 00000000		
0xB0B38480		SPI1_TXFIFO12 00000000 00000000 00000000 00000000		
0xB0B38484		SPI1_TXFIFO13 00000000 00000000 00000000 00000000		
0xB0B38488		SPI1_TXFIFO14 00000000 00000000 00000000 00000000		
0xB0B3848C		SPI1_TXFIFO15 00000000 00000000 00000000 00000000		
0xB0B38490		SPI1_RXFIFO0 00000000 00000000 00000000 00000000		
0xB0B38494		SPI1_RXFIFO1 00000000 00000000 00000000 00000000		
0xB0B38498		SPI1_RXFIFO2 00000000 00000000 00000000 00000000		
0xB0B3849C		SPI1_RXFIFO3 00000000 00000000 00000000 00000000		
0xB0B384A0		SPI1_RXFIFO4 00000000 00000000 00000000 00000000		
0xB0B384A4		SPI1_RXFIFO5 00000000 00000000 00000000 00000000		
0xB0B384A8		SPI1_RXFIFO6 00000000 00000000 00000000 00000000		
0xB0B384AC		SPI1_RXFIFO7 00000000 00000000 00000000 00000000		
0xB0B384B0		SPI1_RXFIFO8 00000000 00000000 00000000 00000000		
0xB0B384B4		SPI1_RXFIFO9 00000000 00000000 00000000 00000000		
0xB0B384B8		SPI1_RXFIFO10 00000000 00000000 00000000 00000000		
0xB0B384BC		SPI1_RXFIFO11 00000000 00000000 00000000 00000000		
0xB0B384C0		SPI1_RXFIFO12 00000000 00000000 00000000 00000000		
0xB0B384C4		SPI1_RXFIFO13 00000000 00000000 00000000 00000000		
0xB0B384C8		SPI1_RXFIFO14 00000000 00000000 00000000 00000000		

Table 38. Memory Layout of PERI4_SLAVE Registers with Default Values (Continued)

Offset	+3	+2	+1	+0
0xB0B384CC	SPI1_RXFIFO15 00000000 00000000 00000000 00000000			
0xB0B384D0- B0B384F8	reserved 00000000 00000000 00000000 00000000			
0xB0B384FC	SPI1_MID 00000000 00000000 00000000 00000001			
0xB0B38500- B0B387FC	reserved XXXXXXXX XXXXXXXX XXXXXXXX XXXXXXXX			
0xB0B38800	SPI2_MCTRL 00000000 00000000 00000000 00000000			
0xB0B38804	SPI2_PCC0 00000000 00000001 00000000 00000000			
0xB0B38808	SPI2_PCC1 00000000 00000001 00000000 00000000			
0xB0B3880C	SPI2_PCC2 00000000 00000001 00000000 00000000			
0xB0B38810	SPI2_PCC3 00000000 00000001 00000000 00000000			
0xB0B38814	SPI2_TXF 00000000 00000000 00000000 00000000			
0xB0B38818	SPI2_TXE 00000000 00000000 00000000 00000000			
0xB0B3881C	SPI2_TXC 00000000 00000000 00000000 00000000			
0xB0B38820	SPI2_RXF 00000000 00000000 00000000 00000000			
0xB0B38824	SPI2_RXE 00000000 00000000 00000000 00000000			
0xB0B38828	SPI2_RXC 00000000 00000000 00000000 00000000			
0xB0B3882C	SPI2_FAULTF 00000000 00000000 00000000 00000000			
0xB0B38830	SPI2_FAULTC 00000000 00000000 00000000 00000000			
0xB0B38834	read0 00000000 00000000		SPI2_DMDMAEN 00000000	SPI2_DMCFG 00000001
0xB0B38838	SPI2_DMTRP 00000000	SPI2_DMPSEL 00000000	SPI2_DMSTOP 00000000	SPI2_DMSTART 00000000
0xB0B3883C	SPI2_DMBCS 00000000 00000000		SPI2_DMBCC 00000000 00000000	
0xB0B38840	SPI2_DMSTATUS 00000000 00000000 00000000 00000000			
0xB0B38844	read0 00000000 00000000		SPI2_RXBITCNT 00000000	SPI2_TXBITCNT 00000000
0xB0B38848	SPI2_RXSHIFT 00000000 00000000 00000000 00000000			
0xB0B3884C	SPI2_FIFOCFG 00000000 00000000 00000000 01110111			
0xB0B38850	SPI2_TXFIFO0 00000000 00000000 00000000 00000000			
0xB0B38854	SPI2_TXFIFO1 00000000 00000000 00000000 00000000			

Table 38. Memory Layout of PERI4_SLAVE Registers with Default Values (Continued)

Offset	+3	+2	+1	+0
0xB0B38858	SPI2_TXFIFO2 00000000 00000000 00000000 00000000			
0xB0B3885C	SPI2_TXFIFO3 00000000 00000000 00000000 00000000			
0xB0B38860	SPI2_TXFIFO4 00000000 00000000 00000000 00000000			
0xB0B38864	SPI2_TXFIFO5 00000000 00000000 00000000 00000000			
0xB0B38868	SPI2_TXFIFO6 00000000 00000000 00000000 00000000			
0xB0B3886C	SPI2_TXFIFO7 00000000 00000000 00000000 00000000			
0xB0B38870	SPI2_TXFIFO8 00000000 00000000 00000000 00000000			
0xB0B38874	SPI2_TXFIFO9 00000000 00000000 00000000 00000000			
0xB0B38878	SPI2_TXFIFO10 00000000 00000000 00000000 00000000			
0xB0B3887C	SPI2_TXFIFO11 00000000 00000000 00000000 00000000			
0xB0B38880	SPI2_TXFIFO12 00000000 00000000 00000000 00000000			
0xB0B38884	SPI2_TXFIFO13 00000000 00000000 00000000 00000000			
0xB0B38888	SPI2_TXFIFO14 00000000 00000000 00000000 00000000			
0xB0B3888C	SPI2_TXFIFO15 00000000 00000000 00000000 00000000			
0xB0B38890	SPI2_RXFIFO0 00000000 00000000 00000000 00000000			
0xB0B38894	SPI2_RXFIFO1 00000000 00000000 00000000 00000000			
0xB0B38898	SPI2_RXFIFO2 00000000 00000000 00000000 00000000			
0xB0B3889C	SPI2_RXFIFO3 00000000 00000000 00000000 00000000			
0xB0B388A0	SPI2_RXFIFO4 00000000 00000000 00000000 00000000			
0xB0B388A4	SPI2_RXFIFO5 00000000 00000000 00000000 00000000			
0xB0B388A8	SPI2_RXFIFO6 00000000 00000000 00000000 00000000			
0xB0B388AC	SPI2_RXFIFO7 00000000 00000000 00000000 00000000			
0xB0B388B0	SPI2_RXFIFO8 00000000 00000000 00000000 00000000			
0xB0B388B4	SPI2_RXFIFO9 00000000 00000000 00000000 00000000			
0xB0B388B8	SPI2_RXFIFO10 00000000 00000000 00000000 00000000			
0xB0B388BC	SPI2_RXFIFO11 00000000 00000000 00000000 00000000			

Table 38. Memory Layout of PERI4_SLAVE Registers with Default Values (Continued)

Offset	+3	+2	+1	+0
0xB0B388C0	SPI2_RXFIFO12 00000000 00000000 00000000 00000000			
0xB0B388C4	SPI2_RXFIFO13 00000000 00000000 00000000 00000000			
0xB0B388C8	SPI2_RXFIFO14 00000000 00000000 00000000 00000000			
0xB0B388CC	SPI2_RXFIFO15 00000000 00000000 00000000 00000000			
0xB0B388D0- B0B388F8	reserved 00000000 00000000 00000000 00000000			
0xB0B388FC	SPI2_MID 00000000 00000000 00000000 00000001			
0xB0B38900- B0BF8FFC	reserved XXXXXXXX XXXXXXXX XXXXXXXX XXXXXXXX			
0xB0BF9000	read0 00000000 00000000	RICFG4_I2S0ECLK 00000000 00000000		
0xB0BF9004	read0 00000000 00000000	RICFG4_I2S0SCKI 00000000 00000000		
0xB0BF9008	read0 00000000 00000000	RICFG4_I2S0SDI 00000000 00000000		
0xB0BF900C	read0 00000000 00000000	RICFG4_I2S0WSI 00000000 00000000		
0xB0BF9010- B0BF901C	reserved 00000000 00000000 00000000 00000000			
0xB0BF9020	read0 00000000 00000000	RICFG4_I2S1ECLK 00000000 00000000		
0xB0BF9024	read0 00000000 00000000	RICFG4_I2S1SCKI 00000000 00000000		
0xB0BF9028	read0 00000000 00000000	RICFG4_I2S1SDI 00000000 00000000		
0xB0BF902C	read0 00000000 00000000	RICFG4_I2S1WSI 00000000 00000000		
0xB0BF9030- B0BF9BFC	reserved 00000000 00000000 00000000 00000000			
0xB0BF9C00	read0 00000000 00000000	RICFG4_SPI0CLKI 00000000 00000000		
0xB0BF9C04	read0 00000000 00000000	RICFG4_SPI0DATA0I 00000000 00000000		
0xB0BF9C08	read0 00000000 00000000	RICFG4_SPI0DATA1I 00000000 00000000		
0xB0BF9C0C	read0 00000000 00000000	RICFG4_SPI0MSTART 00000000 00000000		
0xB0BF9C10	read0 00000000 00000000	RICFG4_SPI0SSI 00000000 00000000		
0xB0BF9C14- B0BF9C1C	reserved 00000000 00000000 00000000 00000000			
0xB0BF9C20	read0 00000000 00000000	RICFG4_SPI1CLKI 00000000 00000000		
0xB0BF9C24	read0 00000000 00000000	RICFG4_SPI1DATA0I 00000000 00000000		

Table 38. Memory Layout of PERI4_SLAVE Registers with Default Values (Continued)

Offset	+3	+2	+1	+0
0xB0BF9C28	read0 00000000 00000000			RICFG4_SPI1DATA1I 00000000 00000000
0xB0BF9C2C	read0 00000000 00000000			RICFG4_SPI1MSTART 00000000 00000000
0xB0BF9C30	read0 00000000 00000000			RICFG4_SPI1SSI 00000000 00000000
0xB0BF9C34- B0BF9C3C	reserved 00000000 00000000 00000000 00000000			
0xB0BF9C40	read0 00000000 00000000			RICFG4_SPI2CLKI 00000000 00000000
0xB0BF9C44	read0 00000000 00000000			RICFG4_SPI2DATA0I 00000000 00000000
0xB0BF9C48	read0 00000000 00000000			RICFG4_SPI2DATA1I 00000000 00000000
0xB0BF9C4C	read0 00000000 00000000			RICFG4_SPI2DATA2I 00000000 00000000
0xB0BF9C50	read0 00000000 00000000			RICFG4_SPI2DATA3I 00000000 00000000
0xB0BF9C54	read0 00000000 00000000			RICFG4_SPI2MSTART 00000000 00000000
0xB0BF9C58	read0 00000000 00000000			RICFG4_SPI2SSI 00000000 00000000
0xB0BF9C5C- B0BFFC00	reserved XXXXXXXX XXXXXXXX XXXXXXXX XXXXXXXX			
0xB0BFFC04	BSU4_BTST 00000000 00000000 00000000 00000000			
0xB0BFFC08- B0BFFC10	reserved XXXXXXXX XXXXXXXX XXXXXXXX XXXXXXXX			
0xB0BFFC14	BSU4_PEN1 00000000 00000000 00000000 00000000			
0xB0BFFC18	BSU4_PEN2 00000000 00000000 00000000 00000000			
0xB0BFFC1C	BSU4_PEN3 00000000 00000000 00000000 00000000			
0xB0BFFC20	BSU4_PEN4 00000000 00000000 00000000 00000000			
0xB0BFFC24	BSU4_PEN5 00000000 00000000 00000000 00000000			
0xB0BFFC28	BSU4_PEN6 00000000 00000000 00000000 00000000			
0xB0BFFC2C	BSU4_PEN7 00000000 00000000 00000000 00000000			
0xB0BFFC30	BSU4_PEN8 00000000 00000000 00000000 00000000			
0xB0BFFC34- B0BFFFFC	reserved XXXXXXXX XXXXXXXX XXXXXXXX XXXXXXXX			

Table 39. Memory Layout of PERI5_AHB Registers with Default Values

Offset	+3	+2	+1	+0
0xB0C00000		DMA0_A0 00000000 00001111 00000000 00000000		
0xB0C00004		DMA0_B0 00000000 00000000 00110011 01111111		
0xB0C00008		DMA0_SA0 00000000 00000000 00000000 00000000		
0xB0C0000C		DMA0_DA0 00000000 00000000 00000000 00000000		
0xB0C00010		DMA0_C0 XXXXXXXX XXXXXXXX 00000000 00000000		
0xB0C00014		DMA0_D0 00000000 XXXXXXXX 00000000 XXXXXXXX		
0xB0C00018		DMA0_SASHDW0 00000000 00000000 00000000 00000000		
0xB0C0001C		DMA0_DASHDW0 00000000 00000000 00000000 00000000		
0xB0C00020- B0C0003C		reserved XXXXXXXX XXXXXXXX XXXXXXXX XXXXXXXX		
0xB0C00040		DMA0_A1 00000000 00001111 00000000 00000000		
0xB0C00044		DMA0_B1 00000000 00000000 00110011 01111111		
0xB0C00048		DMA0_SA1 00000000 00000000 00000000 00000000		
0xB0C0004C		DMA0_DA1 00000000 00000000 00000000 00000000		
0xB0C00050		DMA0_C1 XXXXXXXX XXXXXXXX 00000000 00000000		
0xB0C00054		DMA0_D1 00000000 XXXXXXXX 00000000 XXXXXXXX		
0xB0C00058		DMA0_SASHDW1 00000000 00000000 00000000 00000000		
0xB0C0005C		DMA0_DASHDW1 00000000 00000000 00000000 00000000		
0xB0C00060- B0C0007C		reserved XXXXXXXX XXXXXXXX XXXXXXXX XXXXXXXX		
0xB0C00080		DMA0_A2 00000000 00001111 00000000 00000000		
0xB0C00084		DMA0_B2 00000000 00000000 00110011 01111111		
0xB0C00088		DMA0_SA2 00000000 00000000 00000000 00000000		
0xB0C0008C		DMA0_DA2 00000000 00000000 00000000 00000000		
0xB0C00090		DMA0_C2 XXXXXXXX XXXXXXXX 00000000 00000000		
0xB0C00094		DMA0_D2 00000000 XXXXXXXX 00000000 XXXXXXXX		
0xB0C00098		DMA0_SASHDW2 00000000 00000000 00000000 00000000		
0xB0C0009C		DMA0_DASHDW2 00000000 00000000 00000000 00000000		

Table 39. Memory Layout of PERI5_AHB Registers with Default Values (Continued)

Offset	+3	+2	+1	+0
0xB0C000A0- B0C000BC	reserved XXXXXXXX XXXXXXXX XXXXXXXX XXXXXXXX			
0xB0C000C0	DMA0_A3 00000000 00001111 00000000 00000000			
0xB0C000C4	DMA0_B3 00000000 00000000 00110011 01111111			
0xB0C000C8	DMA0_SA3 00000000 00000000 00000000 00000000			
0xB0C000CC	DMA0_DA3 00000000 00000000 00000000 00000000			
0xB0C000D0	DMA0_C3 XXXXXXXX XXXXXXXX 00000000 00000000			
0xB0C000D4	DMA0_D3 00000000 XXXXXXXX 00000000 XXXXXXXX			
0xB0C000D8	DMA0_SASHDW3 00000000 00000000 00000000 00000000			
0xB0C000DC	DMA0_DASHDW3 00000000 00000000 00000000 00000000			
0xB0C000E0- B0C000FC	reserved XXXXXXXX XXXXXXXX XXXXXXXX XXXXXXXX			
0xB0C00100	DMA0_A4 00000000 00001111 00000000 00000000			
0xB0C00104	DMA0_B4 00000000 00000000 00110011 01111111			
0xB0C00108	DMA0_SA4 00000000 00000000 00000000 00000000			
0xB0C0010C	DMA0_DA4 00000000 00000000 00000000 00000000			
0xB0C00110	DMA0_C4 XXXXXXXX XXXXXXXX 00000000 00000000			
0xB0C00114	DMA0_D4 00000000 XXXXXXXX 00000000 XXXXXXXX			
0xB0C00118	DMA0_SASHDW4 00000000 00000000 00000000 00000000			
0xB0C0011C	DMA0_DASHDW4 00000000 00000000 00000000 00000000			
0xB0C00120- B0C0013C	reserved XXXXXXXX XXXXXXXX XXXXXXXX XXXXXXXX			
0xB0C00140	DMA0_A5 00000000 00001111 00000000 00000000			
0xB0C00144	DMA0_B5 00000000 00000000 00110011 01111111			
0xB0C00148	DMA0_SA5 00000000 00000000 00000000 00000000			
0xB0C0014C	DMA0_DA5 00000000 00000000 00000000 00000000			
0xB0C00150	DMA0_C5 XXXXXXXX XXXXXXXX 00000000 00000000			
0xB0C00154	DMA0_D5 00000000 XXXXXXXX 00000000 XXXXXXXX			
0xB0C00158	DMA0_SASHDW5 00000000 00000000 00000000 00000000			

Table 39. Memory Layout of PERI5_AHB Registers with Default Values (Continued)

Offset	+3	+2	+1	+0
0xB0C0015C		DMA0_DASHDW5 00000000 00000000 00000000 00000000		
0xB0C00160- B0C0017C		reserved XXXXXXXX XXXXXXXX XXXXXXXX XXXXXXXX		
0xB0C00180		DMA0_A6 00000000 00001111 00000000 00000000		
0xB0C00184		DMA0_B6 00000000 00000000 00110011 01111111		
0xB0C00188		DMA0_SA6 00000000 00000000 00000000 00000000		
0xB0C0018C		DMA0_DA6 00000000 00000000 00000000 00000000		
0xB0C00190		DMA0_C6 XXXXXXXX XXXXXXXX 00000000 00000000		
0xB0C00194		DMA0_D6 00000000 XXXXXXXX 00000000 XXXXXXXX		
0xB0C00198		DMA0_SASHDW6 00000000 00000000 00000000 00000000		
0xB0C0019C		DMA0_DASHDW6 00000000 00000000 00000000 00000000		
0xB0C001A0- B0C001BC		reserved XXXXXXXX XXXXXXXX XXXXXXXX XXXXXXXX		
0xB0C001C0		DMA0_A7 00000000 00001111 00000000 00000000		
0xB0C001C4		DMA0_B7 00000000 00000000 00110011 01111111		
0xB0C001C8		DMA0_SA7 00000000 00000000 00000000 00000000		
0xB0C001CC		DMA0_DA7 00000000 00000000 00000000 00000000		
0xB0C001D0		DMA0_C7 XXXXXXXX XXXXXXXX 00000000 00000000		
0xB0C001D4		DMA0_D7 00000000 XXXXXXXX 00000000 XXXXXXXX		
0xB0C001D8		DMA0_SASHDW7 00000000 00000000 00000000 00000000		
0xB0C001DC		DMA0_DASHDW7 00000000 00000000 00000000 00000000		
0xB0C001E0- B0C001FC		reserved XXXXXXXX XXXXXXXX XXXXXXXX XXXXXXXX		
0xB0C00200		DMA0_A8 00000000 00001111 00000000 00000000		
0xB0C00204		DMA0_B8 00000000 00000000 00110011 01111111		
0xB0C00208		DMA0_SA8 00000000 00000000 00000000 00000000		
0xB0C0020C		DMA0_DA8 00000000 00000000 00000000 00000000		
0xB0C00210		DMA0_C8 XXXXXXXX XXXXXXXX 00000000 00000000		
0xB0C00214		DMA0_D8 00000000 XXXXXXXX 00000000 XXXXXXXX		

Table 39. Memory Layout of PERI5_AHB Registers with Default Values (Continued)

Offset	+3	+2	+1	+0
0xB0C00218		DMA0_SASHDW8 00000000 00000000 00000000 00000000		
0xB0C0021C		DMA0_DASHDW8 00000000 00000000 00000000 00000000		
0xB0C00220- B0C0023C		reserved XXXXXXXX XXXXXXXX XXXXXXXX XXXXXXXX		
0xB0C00240		DMA0_A9 00000000 00001111 00000000 00000000		
0xB0C00244		DMA0_B9 00000000 00000000 00110011 01111111		
0xB0C00248		DMA0_SA9 00000000 00000000 00000000 00000000		
0xB0C0024C		DMA0_DA9 00000000 00000000 00000000 00000000		
0xB0C00250		DMA0_C9 XXXXXXXX XXXXXXXX 00000000 00000000		
0xB0C00254		DMA0_D9 00000000 XXXXXXXX 00000000 XXXXXXXX		
0xB0C00258		DMA0_SASHDW9 00000000 00000000 00000000 00000000		
0xB0C0025C		DMA0_DASHDW9 00000000 00000000 00000000 00000000		
0xB0C00260- B0C0027C		reserved XXXXXXXX XXXXXXXX XXXXXXXX XXXXXXXX		
0xB0C00280		DMA0_A10 00000000 00001111 00000000 00000000		
0xB0C00284		DMA0_B10 00000000 00000000 00110011 01111111		
0xB0C00288		DMA0_SA10 00000000 00000000 00000000 00000000		
0xB0C0028C		DMA0_DA10 00000000 00000000 00000000 00000000		
0xB0C00290		DMA0_C10 XXXXXXXX XXXXXXXX 00000000 00000000		
0xB0C00294		DMA0_D10 00000000 XXXXXXXX 00000000 XXXXXXXX		
0xB0C00298		DMA0_SASHDW10 00000000 00000000 00000000 00000000		
0xB0C0029C		DMA0_DASHDW10 00000000 00000000 00000000 00000000		
0xB0C002A0- B0C002BC		reserved XXXXXXXX XXXXXXXX XXXXXXXX XXXXXXXX		
0xB0C002C0		DMA0_A11 00000000 00001111 00000000 00000000		
0xB0C002C4		DMA0_B11 00000000 00000000 00110011 01111111		
0xB0C002C8		DMA0_SA11 00000000 00000000 00000000 00000000		
0xB0C002CC		DMA0_DA11 00000000 00000000 00000000 00000000		
0xB0C002D0		DMA0_C11 XXXXXXXX XXXXXXXX 00000000 00000000		

Table 39. Memory Layout of PERI5_AHB Registers with Default Values (Continued)

Offset	+3	+2	+1	+0
0xB0C002D4		DMA0_D11 00000000 XXXXXXXX 00000000 XXXXXXXX		
0xB0C002D8		DMA0_SASHDW11 00000000 00000000 00000000 00000000		
0xB0C002DC		DMA0_DASHDW11 00000000 00000000 00000000 00000000		
0xB0C002E0- B0C002FC		reserved XXXXXXXX XXXXXXXX XXXXXXXX XXXXXXXX		
0xB0C00300		DMA0_A12 00000000 00001111 00000000 00000000		
0xB0C00304		DMA0_B12 00000000 00000000 00110011 01111111		
0xB0C00308		DMA0_SA12 00000000 00000000 00000000 00000000		
0xB0C0030C		DMA0_DA12 00000000 00000000 00000000 00000000		
0xB0C00310		DMA0_C12 XXXXXXXX XXXXXXXX 00000000 00000000		
0xB0C00314		DMA0_D12 00000000 XXXXXXXX 00000000 XXXXXXXX		
0xB0C00318		DMA0_SASHDW12 00000000 00000000 00000000 00000000		
0xB0C0031C		DMA0_DASHDW12 00000000 00000000 00000000 00000000		
0xB0C00320- B0C0033C		reserved XXXXXXXX XXXXXXXX XXXXXXXX XXXXXXXX		
0xB0C00340		DMA0_A13 00000000 00001111 00000000 00000000		
0xB0C00344		DMA0_B13 00000000 00000000 00110011 01111111		
0xB0C00348		DMA0_SA13 00000000 00000000 00000000 00000000		
0xB0C0034C		DMA0_DA13 00000000 00000000 00000000 00000000		
0xB0C00350		DMA0_C13 XXXXXXXX XXXXXXXX 00000000 00000000		
0xB0C00354		DMA0_D13 00000000 XXXXXXXX 00000000 XXXXXXXX		
0xB0C00358		DMA0_SASHDW13 00000000 00000000 00000000 00000000		
0xB0C0035C		DMA0_DASHDW13 00000000 00000000 00000000 00000000		
0xB0C00360- B0C0037C		reserved XXXXXXXX XXXXXXXX XXXXXXXX XXXXXXXX		
0xB0C00380		DMA0_A14 00000000 00001111 00000000 00000000		
0xB0C00384		DMA0_B14 00000000 00000000 00110011 01111111		
0xB0C00388		DMA0_SA14 00000000 00000000 00000000 00000000		
0xB0C0038C		DMA0_DA14 00000000 00000000 00000000 00000000		

Table 39. Memory Layout of PERI5_AHB Registers with Default Values (Continued)

Offset	+3	+2	+1	+0
0xB0C00390		DMA0_C14 XXXXXXXX XXXXXXXX 00000000 00000000		
0xB0C00394		DMA0_D14 00000000 XXXXXXXX 00000000 XXXXXXXX		
0xB0C00398		DMA0_SASHDW14 00000000 00000000 00000000 00000000		
0xB0C0039C		DMA0_DASHDW14 00000000 00000000 00000000 00000000		
0xB0C003A0- B0C003BC		reserved XXXXXXXX XXXXXXXX XXXXXXXX XXXXXXXX		
0xB0C003C0		DMA0_A15 00000000 00001111 00000000 00000000		
0xB0C003C4		DMA0_B15 00000000 00000000 00110011 01111111		
0xB0C003C8		DMA0_SA15 00000000 00000000 00000000 00000000		
0xB0C003CC		DMA0_DA15 00000000 00000000 00000000 00000000		
0xB0C003D0		DMA0_C15 XXXXXXXX XXXXXXXX 00000000 00000000		
0xB0C003D4		DMA0_D15 00000000 XXXXXXXX 00000000 XXXXXXXX		
0xB0C003D8		DMA0_SASHDW15 00000000 00000000 00000000 00000000		
0xB0C003DC		DMA0_DASHDW15 00000000 00000000 00000000 00000000		
0xB0C003E0- B0C003FC		reserved XXXXXXXX XXXXXXXX XXXXXXXX XXXXXXXX		
0xB0C00400		DMA0_A16 00000000 00001111 00000000 00000000		
0xB0C00404		DMA0_B16 00000000 00000000 00110011 01111111		
0xB0C00408		DMA0_SA16 00000000 00000000 00000000 00000000		
0xB0C0040C		DMA0_DA16 00000000 00000000 00000000 00000000		
0xB0C00410		DMA0_C16 XXXXXXXX XXXXXXXX 00000000 00000000		
0xB0C00414		DMA0_D16 00000000 XXXXXXXX 00000000 XXXXXXXX		
0xB0C00418		DMA0_SASHDW16 00000000 00000000 00000000 00000000		
0xB0C0041C		DMA0_DASHDW16 00000000 00000000 00000000 00000000		
0xB0C00420- B0C0043C		reserved XXXXXXXX XXXXXXXX XXXXXXXX XXXXXXXX		
0xB0C00440		DMA0_A17 00000000 00001111 00000000 00000000		
0xB0C00444		DMA0_B17 00000000 00000000 00110011 01111111		
0xB0C00448		DMA0_SA17 00000000 00000000 00000000 00000000		

Table 39. Memory Layout of PERI5_AHB Registers with Default Values (Continued)

Offset	+3	+2	+1	+0
0xB0C0044C		DMA0_DA17 00000000 00000000 00000000 00000000		
0xB0C00450		DMA0_C17 XXXXXXXX XXXXXXXX 00000000 00000000		
0xB0C00454		DMA0_D17 00000000 XXXXXXXX 00000000 XXXXXXXX		
0xB0C00458		DMA0_SASHDW17 00000000 00000000 00000000 00000000		
0xB0C0045C		DMA0_DASHDW17 00000000 00000000 00000000 00000000		
0xB0C00460- B0C0047C		reserved XXXXXXXX XXXXXXXX XXXXXXXX XXXXXXXX		
0xB0C00480		DMA0_A18 00000000 00001111 00000000 00000000		
0xB0C00484		DMA0_B18 00000000 00000000 00110011 01111111		
0xB0C00488		DMA0_SA18 00000000 00000000 00000000 00000000		
0xB0C0048C		DMA0_DA18 00000000 00000000 00000000 00000000		
0xB0C00490		DMA0_C18 XXXXXXXX XXXXXXXX 00000000 00000000		
0xB0C00494		DMA0_D18 00000000 XXXXXXXX 00000000 XXXXXXXX		
0xB0C00498		DMA0_SASHDW18 00000000 00000000 00000000 00000000		
0xB0C0049C		DMA0_DASHDW18 00000000 00000000 00000000 00000000		
0xB0C004A0- B0C004BC		reserved XXXXXXXX XXXXXXXX XXXXXXXX XXXXXXXX		
0xB0C004C0		DMA0_A19 00000000 00001111 00000000 00000000		
0xB0C004C4		DMA0_B19 00000000 00000000 00110011 01111111		
0xB0C004C8		DMA0_SA19 00000000 00000000 00000000 00000000		
0xB0C004CC		DMA0_DA19 00000000 00000000 00000000 00000000		
0xB0C004D0		DMA0_C19 XXXXXXXX XXXXXXXX 00000000 00000000		
0xB0C004D4		DMA0_D19 00000000 XXXXXXXX 00000000 XXXXXXXX		
0xB0C004D8		DMA0_SASHDW19 00000000 00000000 00000000 00000000		
0xB0C004DC		DMA0_DASHDW19 00000000 00000000 00000000 00000000		
0xB0C004E0- B0C004FC		reserved XXXXXXXX XXXXXXXX XXXXXXXX XXXXXXXX		
0xB0C00500		DMA0_A20 00000000 00001111 00000000 00000000		
0xB0C00504		DMA0_B20 00000000 00000000 00110011 01111111		

Table 39. Memory Layout of PERI5_AHB Registers with Default Values (Continued)

Offset	+3	+2	+1	+0
0xB0C00508		DMA0_SA20 00000000 00000000 00000000 00000000		
0xB0C0050C		DMA0_DA20 00000000 00000000 00000000 00000000		
0xB0C00510		DMA0_C20 XXXXXXXX XXXXXXXX 00000000 00000000		
0xB0C00514		DMA0_D20 00000000 XXXXXXXX 00000000 XXXXXXXX		
0xB0C00518		DMA0_SASHDW20 00000000 00000000 00000000 00000000		
0xB0C0051C		DMA0_DASHDW20 00000000 00000000 00000000 00000000		
0xB0C00520- B0C0053C		reserved XXXXXXXX XXXXXXXX XXXXXXXX XXXXXXXX		
0xB0C00540		DMA0_A21 00000000 00001111 00000000 00000000		
0xB0C00544		DMA0_B21 00000000 00000000 00110011 01111111		
0xB0C00548		DMA0_SA21 00000000 00000000 00000000 00000000		
0xB0C0054C		DMA0_DA21 00000000 00000000 00000000 00000000		
0xB0C00550		DMA0_C21 XXXXXXXX XXXXXXXX 00000000 00000000		
0xB0C00554		DMA0_D21 00000000 XXXXXXXX 00000000 XXXXXXXX		
0xB0C00558		DMA0_SASHDW21 00000000 00000000 00000000 00000000		
0xB0C0055C		DMA0_DASHDW21 00000000 00000000 00000000 00000000		
0xB0C00560- B0C0057C		reserved XXXXXXXX XXXXXXXX XXXXXXXX XXXXXXXX		
0xB0C00580		DMA0_A22 00000000 00001111 00000000 00000000		
0xB0C00584		DMA0_B22 00000000 00000000 00110011 01111111		
0xB0C00588		DMA0_SA22 00000000 00000000 00000000 00000000		
0xB0C0058C		DMA0_DA22 00000000 00000000 00000000 00000000		
0xB0C00590		DMA0_C22 XXXXXXXX XXXXXXXX 00000000 00000000		
0xB0C00594		DMA0_D22 00000000 XXXXXXXX 00000000 XXXXXXXX		
0xB0C00598		DMA0_SASHDW22 00000000 00000000 00000000 00000000		
0xB0C0059C		DMA0_DASHDW22 00000000 00000000 00000000 00000000		
0xB0C005A0- B0C005BC		reserved XXXXXXXX XXXXXXXX XXXXXXXX XXXXXXXX		
0xB0C005C0		DMA0_A23 00000000 00001111 00000000 00000000		

Table 39. Memory Layout of PERI5_AHB Registers with Default Values (Continued)

Offset	+3	+2	+1	+0
0xB0C005C4		DMA0_B23 00000000 00000000 00110011 01111111		
0xB0C005C8		DMA0_SA23 00000000 00000000 00000000 00000000		
0xB0C005CC		DMA0_DA23 00000000 00000000 00000000 00000000		
0xB0C005D0		DMA0_C23 XXXXXXXX XXXXXXXX 00000000 00000000		
0xB0C005D4		DMA0_D23 00000000 XXXXXXXX 00000000 XXXXXXXX		
0xB0C005D8		DMA0_SASHDW23 00000000 00000000 00000000 00000000		
0xB0C005DC		DMA0_DASHDW23 00000000 00000000 00000000 00000000		
0xB0C005E0- B0C005FC		reserved XXXXXXXX XXXXXXXX XXXXXXXX XXXXXXXX		
0xB0C00600		DMA0_A24 00000000 00001111 00000000 00000000		
0xB0C00604		DMA0_B24 00000000 00000000 00110011 01111111		
0xB0C00608		DMA0_SA24 00000000 00000000 00000000 00000000		
0xB0C0060C		DMA0_DA24 00000000 00000000 00000000 00000000		
0xB0C00610		DMA0_C24 XXXXXXXX XXXXXXXX 00000000 00000000		
0xB0C00614		DMA0_D24 00000000 XXXXXXXX 00000000 XXXXXXXX		
0xB0C00618		DMA0_SASHDW24 00000000 00000000 00000000 00000000		
0xB0C0061C		DMA0_DASHDW24 00000000 00000000 00000000 00000000		
0xB0C00620- B0C0063C		reserved XXXXXXXX XXXXXXXX XXXXXXXX XXXXXXXX		
0xB0C00640		DMA0_A25 00000000 00001111 00000000 00000000		
0xB0C00644		DMA0_B25 00000000 00000000 00110011 01111111		
0xB0C00648		DMA0_SA25 00000000 00000000 00000000 00000000		
0xB0C0064C		DMA0_DA25 00000000 00000000 00000000 00000000		
0xB0C00650		DMA0_C25 XXXXXXXX XXXXXXXX 00000000 00000000		
0xB0C00654		DMA0_D25 00000000 XXXXXXXX 00000000 XXXXXXXX		
0xB0C00658		DMA0_SASHDW25 00000000 00000000 00000000 00000000		
0xB0C0065C		DMA0_DASHDW25 00000000 00000000 00000000 00000000		
0xB0C00660- B0C0067C		reserved XXXXXXXX XXXXXXXX XXXXXXXX XXXXXXXX		

Table 39. Memory Layout of PERI5_AHB Registers with Default Values (Continued)

Offset	+3	+2	+1	+0
0xB0C00680		DMA0_A26 00000000 00001111 00000000 00000000		
0xB0C00684		DMA0_B26 00000000 00000000 00110011 01111111		
0xB0C00688		DMA0_SA26 00000000 00000000 00000000 00000000		
0xB0C0068C		DMA0_DA26 00000000 00000000 00000000 00000000		
0xB0C00690		DMA0_C26 XXXXXXXX XXXXXXXX 00000000 00000000		
0xB0C00694		DMA0_D26 00000000 XXXXXXXX 00000000 XXXXXXXX		
0xB0C00698		DMA0_SASHDW26 00000000 00000000 00000000 00000000		
0xB0C0069C		DMA0_DASHDW26 00000000 00000000 00000000 00000000		
0xB0C006A0- B0C006BC		reserved XXXXXXXX XXXXXXXX XXXXXXXX XXXXXXXX		
0xB0C006C0		DMA0_A27 00000000 00001111 00000000 00000000		
0xB0C006C4		DMA0_B27 00000000 00000000 00110011 01111111		
0xB0C006C8		DMA0_SA27 00000000 00000000 00000000 00000000		
0xB0C006CC		DMA0_DA27 00000000 00000000 00000000 00000000		
0xB0C006D0		DMA0_C27 XXXXXXXX XXXXXXXX 00000000 00000000		
0xB0C006D4		DMA0_D27 00000000 XXXXXXXX 00000000 XXXXXXXX		
0xB0C006D8		DMA0_SASHDW27 00000000 00000000 00000000 00000000		
0xB0C006DC		DMA0_DASHDW27 00000000 00000000 00000000 00000000		
0xB0C006E0- B0C006FC		reserved XXXXXXXX XXXXXXXX XXXXXXXX XXXXXXXX		
0xB0C00700		DMA0_A28 00000000 00001111 00000000 00000000		
0xB0C00704		DMA0_B28 00000000 00000000 00110011 01111111		
0xB0C00708		DMA0_SA28 00000000 00000000 00000000 00000000		
0xB0C0070C		DMA0_DA28 00000000 00000000 00000000 00000000		
0xB0C00710		DMA0_C28 XXXXXXXX XXXXXXXX 00000000 00000000		
0xB0C00714		DMA0_D28 00000000 XXXXXXXX 00000000 XXXXXXXX		
0xB0C00718		DMA0_SASHDW28 00000000 00000000 00000000 00000000		
0xB0C0071C		DMA0_DASHDW28 00000000 00000000 00000000 00000000		

Table 39. Memory Layout of PERI5_AHB Registers with Default Values (Continued)

Offset	+3	+2	+1	+0
0xB0C00720- B0C0073C	reserved XXXXXXXX XXXXXXXX XXXXXXXX XXXXXXXX			
0xB0C00740	DMA0_A29 00000000 00001111 00000000 00000000			
0xB0C00744	DMA0_B29 00000000 00000000 00110011 01111111			
0xB0C00748	DMA0_SA29 00000000 00000000 00000000 00000000			
0xB0C0074C	DMA0_DA29 00000000 00000000 00000000 00000000			
0xB0C00750	DMA0_C29 XXXXXXXX XXXXXXXX 00000000 00000000			
0xB0C00754	DMA0_D29 00000000 XXXXXXXX 00000000 XXXXXXXX			
0xB0C00758	DMA0_SASHDW29 00000000 00000000 00000000 00000000			
0xB0C0075C	DMA0_DASHDW29 00000000 00000000 00000000 00000000			
0xB0C00760- B0C0077C	reserved XXXXXXXX XXXXXXXX XXXXXXXX XXXXXXXX			
0xB0C00780	DMA0_A30 00000000 00001111 00000000 00000000			
0xB0C00784	DMA0_B30 00000000 00000000 00110011 01111111			
0xB0C00788	DMA0_SA30 00000000 00000000 00000000 00000000			
0xB0C0078C	DMA0_DA30 00000000 00000000 00000000 00000000			
0xB0C00790	DMA0_C30 XXXXXXXX XXXXXXXX 00000000 00000000			
0xB0C00794	DMA0_D30 00000000 XXXXXXXX 00000000 XXXXXXXX			
0xB0C00798	DMA0_SASHDW30 00000000 00000000 00000000 00000000			
0xB0C0079C	DMA0_DASHDW30 00000000 00000000 00000000 00000000			
0xB0C007A0- B0C007BC	reserved XXXXXXXX XXXXXXXX XXXXXXXX XXXXXXXX			
0xB0C007C0	DMA0_A31 00000000 00001111 00000000 00000000			
0xB0C007C4	DMA0_B31 00000000 00000000 00110011 01111111			
0xB0C007C8	DMA0_SA31 00000000 00000000 00000000 00000000			
0xB0C007CC	DMA0_DA31 00000000 00000000 00000000 00000000			
0xB0C007D0	DMA0_C31 XXXXXXXX XXXXXXXX 00000000 00000000			
0xB0C007D4	DMA0_D31 00000000 XXXXXXXX 00000000 XXXXXXXX			
0xB0C007D8	DMA0_SASHDW31 00000000 00000000 00000000 00000000			

Table 39. Memory Layout of PERI5_AHB Registers with Default Values (Continued)

Offset	+3	+2	+1	+0
0xB0C007DC		DMA0_DASHDW31 00000000 00000000 00000000 00000000		
0xB0C007E0- B0C007FC		reserved XXXXXXXX XXXXXXXX XXXXXXXX XXXXXXXX		
0xB0C00800		DMA0_A32 00000000 00001111 00000000 00000000		
0xB0C00804		DMA0_B32 00000000 00000000 00110011 01111111		
0xB0C00808		DMA0_SA32 00000000 00000000 00000000 00000000		
0xB0C0080C		DMA0_DA32 00000000 00000000 00000000 00000000		
0xB0C00810		DMA0_C32 XXXXXXXX XXXXXXXX 00000000 00000000		
0xB0C00814		DMA0_D32 00000000 XXXXXXXX 00000000 XXXXXXXX		
0xB0C00818		DMA0_SASHDW32 00000000 00000000 00000000 00000000		
0xB0C0081C		DMA0_DASHDW32 00000000 00000000 00000000 00000000		
0xB0C00820- B0C0083C		reserved XXXXXXXX XXXXXXXX XXXXXXXX XXXXXXXX		
0xB0C00840		DMA0_A33 00000000 00001111 00000000 00000000		
0xB0C00844		DMA0_B33 00000000 00000000 00110011 01111111		
0xB0C00848		DMA0_SA33 00000000 00000000 00000000 00000000		
0xB0C0084C		DMA0_DA33 00000000 00000000 00000000 00000000		
0xB0C00850		DMA0_C33 XXXXXXXX XXXXXXXX 00000000 00000000		
0xB0C00854		DMA0_D33 00000000 XXXXXXXX 00000000 XXXXXXXX		
0xB0C00858		DMA0_SASHDW33 00000000 00000000 00000000 00000000		
0xB0C0085C		DMA0_DASHDW33 00000000 00000000 00000000 00000000		
0xB0C00860- B0C0087C		reserved XXXXXXXX XXXXXXXX XXXXXXXX XXXXXXXX		
0xB0C00880		DMA0_A34 00000000 00001111 00000000 00000000		
0xB0C00884		DMA0_B34 00000000 00000000 00110011 01111111		
0xB0C00888		DMA0_SA34 00000000 00000000 00000000 00000000		
0xB0C0088C		DMA0_DA34 00000000 00000000 00000000 00000000		
0xB0C00890		DMA0_C34 XXXXXXXX XXXXXXXX 00000000 00000000		
0xB0C00894		DMA0_D34 00000000 XXXXXXXX 00000000 XXXXXXXX		

Table 39. Memory Layout of PERI5_AHB Registers with Default Values (Continued)

Offset	+3	+2	+1	+0
0xB0C00898		DMA0_SASHDW34 00000000 00000000 00000000 00000000		
0xB0C0089C		DMA0_DASHDW34 00000000 00000000 00000000 00000000		
0xB0C008A0- B0C008BC		reserved XXXXXXXX XXXXXXXX XXXXXXXX XXXXXXXX		
0xB0C008C0		DMA0_A35 00000000 00001111 00000000 00000000		
0xB0C008C4		DMA0_B35 00000000 00000000 00110011 01111111		
0xB0C008C8		DMA0_SA35 00000000 00000000 00000000 00000000		
0xB0C008CC		DMA0_DA35 00000000 00000000 00000000 00000000		
0xB0C008D0		DMA0_C35 XXXXXXXX XXXXXXXX 00000000 00000000		
0xB0C008D4		DMA0_D35 00000000 XXXXXXXX 00000000 XXXXXXXX		
0xB0C008D8		DMA0_SASHDW35 00000000 00000000 00000000 00000000		
0xB0C008DC		DMA0_DASHDW35 00000000 00000000 00000000 00000000		
0xB0C008E0- B0C008FC		reserved XXXXXXXX XXXXXXXX XXXXXXXX XXXXXXXX		
0xB0C00900		DMA0_A36 00000000 00001111 00000000 00000000		
0xB0C00904		DMA0_B36 00000000 00000000 00110011 01111111		
0xB0C00908		DMA0_SA36 00000000 00000000 00000000 00000000		
0xB0C0090C		DMA0_DA36 00000000 00000000 00000000 00000000		
0xB0C00910		DMA0_C36 XXXXXXXX XXXXXXXX 00000000 00000000		
0xB0C00914		DMA0_D36 00000000 XXXXXXXX 00000000 XXXXXXXX		
0xB0C00918		DMA0_SASHDW36 00000000 00000000 00000000 00000000		
0xB0C0091C		DMA0_DASHDW36 00000000 00000000 00000000 00000000		
0xB0C00920- B0C0093C		reserved XXXXXXXX XXXXXXXX XXXXXXXX XXXXXXXX		
0xB0C00940		DMA0_A37 00000000 00001111 00000000 00000000		
0xB0C00944		DMA0_B37 00000000 00000000 00110011 01111111		
0xB0C00948		DMA0_SA37 00000000 00000000 00000000 00000000		
0xB0C0094C		DMA0_DA37 00000000 00000000 00000000 00000000		
0xB0C00950		DMA0_C37 XXXXXXXX XXXXXXXX 00000000 00000000		

Table 39. Memory Layout of PERI5_AHB Registers with Default Values (Continued)

Offset	+3	+2	+1	+0
0xB0C00954		DMA0_D37 00000000 XXXXXXXX 00000000 XXXXXXXX		
0xB0C00958		DMA0_SASHDW37 00000000 00000000 00000000 00000000		
0xB0C0095C		DMA0_DASHDW37 00000000 00000000 00000000 00000000		
0xB0C00960- B0C0097C		reserved XXXXXXXX XXXXXXXX XXXXXXXX XXXXXXXX		
0xB0C00980		DMA0_A38 00000000 00001111 00000000 00000000		
0xB0C00984		DMA0_B38 00000000 00000000 00110011 01111111		
0xB0C00988		DMA0_SA38 00000000 00000000 00000000 00000000		
0xB0C0098C		DMA0_DA38 00000000 00000000 00000000 00000000		
0xB0C00990		DMA0_C38 XXXXXXXX XXXXXXXX 00000000 00000000		
0xB0C00994		DMA0_D38 00000000 XXXXXXXX 00000000 XXXXXXXX		
0xB0C00998		DMA0_SASHDW38 00000000 00000000 00000000 00000000		
0xB0C0099C		DMA0_DASHDW38 00000000 00000000 00000000 00000000		
0xB0C009A0- B0C009BC		reserved XXXXXXXX XXXXXXXX XXXXXXXX XXXXXXXX		
0xB0C009C0		DMA0_A39 00000000 00001111 00000000 00000000		
0xB0C009C4		DMA0_B39 00000000 00000000 00110011 01111111		
0xB0C009C8		DMA0_SA39 00000000 00000000 00000000 00000000		
0xB0C009CC		DMA0_DA39 00000000 00000000 00000000 00000000		
0xB0C009D0		DMA0_C39 XXXXXXXX XXXXXXXX 00000000 00000000		
0xB0C009D4		DMA0_D39 00000000 XXXXXXXX 00000000 XXXXXXXX		
0xB0C009D8		DMA0_SASHDW39 00000000 00000000 00000000 00000000		
0xB0C009DC		DMA0_DASHDW39 00000000 00000000 00000000 00000000		
0xB0C009E0- B0C009FC		reserved XXXXXXXX XXXXXXXX XXXXXXXX XXXXXXXX		
0xB0C00A00		DMA0_A40 00000000 00001111 00000000 00000000		
0xB0C00A04		DMA0_B40 00000000 00000000 00110011 01111111		
0xB0C00A08		DMA0_SA40 00000000 00000000 00000000 00000000		
0xB0C00A0C		DMA0_DA40 00000000 00000000 00000000 00000000		

Table 39. Memory Layout of PERI5_AHB Registers with Default Values (Continued)

Offset	+3	+2	+1	+0
0xB0C00A10		DMA0_C40 XXXXXXXX XXXXXXXX 00000000 00000000		
0xB0C00A14		DMA0_D40 00000000 XXXXXXXX 00000000 XXXXXXXX		
0xB0C00A18		DMA0_SASHDW40 00000000 00000000 00000000 00000000		
0xB0C00A1C		DMA0_DASHDW40 00000000 00000000 00000000 00000000		
0xB0C00A20- B0C00A3C		reserved XXXXXXXX XXXXXXXX XXXXXXXX XXXXXXXX		
0xB0C00A40		DMA0_A41 00000000 00001111 00000000 00000000		
0xB0C00A44		DMA0_B41 00000000 00000000 00110011 01111111		
0xB0C00A48		DMA0_SA41 00000000 00000000 00000000 00000000		
0xB0C00A4C		DMA0_DA41 00000000 00000000 00000000 00000000		
0xB0C00A50		DMA0_C41 XXXXXXXX XXXXXXXX 00000000 00000000		
0xB0C00A54		DMA0_D41 00000000 XXXXXXXX 00000000 XXXXXXXX		
0xB0C00A58		DMA0_SASHDW41 00000000 00000000 00000000 00000000		
0xB0C00A5C		DMA0_DASHDW41 00000000 00000000 00000000 00000000		
0xB0C00A60- B0C00A7C		reserved XXXXXXXX XXXXXXXX XXXXXXXX XXXXXXXX		
0xB0C00A80		DMA0_A42 00000000 00001111 00000000 00000000		
0xB0C00A84		DMA0_B42 00000000 00000000 00110011 01111111		
0xB0C00A88		DMA0_SA42 00000000 00000000 00000000 00000000		
0xB0C00A8C		DMA0_DA42 00000000 00000000 00000000 00000000		
0xB0C00A90		DMA0_C42 XXXXXXXX XXXXXXXX 00000000 00000000		
0xB0C00A94		DMA0_D42 00000000 XXXXXXXX 00000000 XXXXXXXX		
0xB0C00A98		DMA0_SASHDW42 00000000 00000000 00000000 00000000		
0xB0C00A9C		DMA0_DASHDW42 00000000 00000000 00000000 00000000		
0xB0C00AA0- B0C00ABC		reserved XXXXXXXX XXXXXXXX XXXXXXXX XXXXXXXX		
0xB0C00AC0		DMA0_A43 00000000 00001111 00000000 00000000		
0xB0C00AC4		DMA0_B43 00000000 00000000 00110011 01111111		
0xB0C00AC8		DMA0_SA43 00000000 00000000 00000000 00000000		

Table 39. Memory Layout of PERI5_AHB Registers with Default Values (Continued)

Offset	+3	+2	+1	+0
0xB0C00ACC		DMA0_DA43 00000000 00000000 00000000 00000000		
0xB0C00AD0		DMA0_C43 XXXXXXXX XXXXXXXX 00000000 00000000		
0xB0C00AD4		DMA0_D43 00000000 XXXXXXXX 00000000 XXXXXXXX		
0xB0C00AD8		DMA0_SASHDW43 00000000 00000000 00000000 00000000		
0xB0C00ADC		DMA0_DASHDW43 00000000 00000000 00000000 00000000		
0xB0C00AE0- B0C00AFC		reserved XXXXXXXX XXXXXXXX XXXXXXXX XXXXXXXX		
0xB0C00B00		DMA0_A44 00000000 00001111 00000000 00000000		
0xB0C00B04		DMA0_B44 00000000 00000000 00110011 01111111		
0xB0C00B08		DMA0_SA44 00000000 00000000 00000000 00000000		
0xB0C00B0C		DMA0_DA44 00000000 00000000 00000000 00000000		
0xB0C00B10		DMA0_C44 XXXXXXXX XXXXXXXX 00000000 00000000		
0xB0C00B14		DMA0_D44 00000000 XXXXXXXX 00000000 XXXXXXXX		
0xB0C00B18		DMA0_SASHDW44 00000000 00000000 00000000 00000000		
0xB0C00B1C		DMA0_DASHDW44 00000000 00000000 00000000 00000000		
0xB0C00B20- B0C00B3C		reserved XXXXXXXX XXXXXXXX XXXXXXXX XXXXXXXX		
0xB0C00B40		DMA0_A45 00000000 00001111 00000000 00000000		
0xB0C00B44		DMA0_B45 00000000 00000000 00110011 01111111		
0xB0C00B48		DMA0_SA45 00000000 00000000 00000000 00000000		
0xB0C00B4C		DMA0_DA45 00000000 00000000 00000000 00000000		
0xB0C00B50		DMA0_C45 XXXXXXXX XXXXXXXX 00000000 00000000		
0xB0C00B54		DMA0_D45 00000000 XXXXXXXX 00000000 XXXXXXXX		
0xB0C00B58		DMA0_SASHDW45 00000000 00000000 00000000 00000000		
0xB0C00B5C		DMA0_DASHDW45 00000000 00000000 00000000 00000000		
0xB0C00B60- B0C00B7C		reserved XXXXXXXX XXXXXXXX XXXXXXXX XXXXXXXX		
0xB0C00B80		DMA0_A46 00000000 00001111 00000000 00000000		
0xB0C00B84		DMA0_B46 00000000 00000000 00110011 01111111		

Table 39. Memory Layout of PERI5_AHB Registers with Default Values (Continued)

Offset	+3	+2	+1	+0
0xB0C00B88		DMA0_SA46 00000000 00000000 00000000 00000000		
0xB0C00B8C		DMA0_DA46 00000000 00000000 00000000 00000000		
0xB0C00B90		DMA0_C46 XXXXXXXX XXXXXXXX 00000000 00000000		
0xB0C00B94		DMA0_D46 00000000 XXXXXXXX 00000000 XXXXXXXX		
0xB0C00B98		DMA0_SASHDW46 00000000 00000000 00000000 00000000		
0xB0C00B9C		DMA0_DASHDW46 00000000 00000000 00000000 00000000		
0xB0C00BA0- B0C00BBC		reserved XXXXXXXX XXXXXXXX XXXXXXXX XXXXXXXX		
0xB0C00BC0		DMA0_A47 00000000 00001111 00000000 00000000		
0xB0C00BC4		DMA0_B47 00000000 00000000 00110011 01111111		
0xB0C00BC8		DMA0_SA47 00000000 00000000 00000000 00000000		
0xB0C00BCC		DMA0_DA47 00000000 00000000 00000000 00000000		
0xB0C00BD0		DMA0_C47 XXXXXXXX XXXXXXXX 00000000 00000000		
0xB0C00BD4		DMA0_D47 00000000 XXXXXXXX 00000000 XXXXXXXX		
0xB0C00BD8		DMA0_SASHDW47 00000000 00000000 00000000 00000000		
0xB0C00BDC		DMA0_DASHDW47 00000000 00000000 00000000 00000000		
0xB0C00BE0- B0C00BFC		reserved XXXXXXXX XXXXXXXX XXXXXXXX XXXXXXXX		
0xB0C00C00		DMA0_A48 00000000 00001111 00000000 00000000		
0xB0C00C04		DMA0_B48 00000000 00000000 00110011 01111111		
0xB0C00C08		DMA0_SA48 00000000 00000000 00000000 00000000		
0xB0C00C0C		DMA0_DA48 00000000 00000000 00000000 00000000		
0xB0C00C10		DMA0_C48 XXXXXXXX XXXXXXXX 00000000 00000000		
0xB0C00C14		DMA0_D48 00000000 XXXXXXXX 00000000 XXXXXXXX		
0xB0C00C18		DMA0_SASHDW48 00000000 00000000 00000000 00000000		
0xB0C00C1C		DMA0_DASHDW48 00000000 00000000 00000000 00000000		
0xB0C00C20- B0C00C3C		reserved XXXXXXXX XXXXXXXX XXXXXXXX XXXXXXXX		
0xB0C00C40		DMA0_A49 00000000 00001111 00000000 00000000		

Table 39. Memory Layout of PERI5_AHB Registers with Default Values (Continued)

Offset	+3	+2	+1	+0
0xB0C00C44		DMA0_B49 00000000 00000000 00110011 01111111		
0xB0C00C48		DMA0_SA49 00000000 00000000 00000000 00000000		
0xB0C00C4C		DMA0_DA49 00000000 00000000 00000000 00000000		
0xB0C00C50		DMA0_C49 XXXXXXXX XXXXXXXX 00000000 00000000		
0xB0C00C54		DMA0_D49 00000000 XXXXXXXX 00000000 XXXXXXXX		
0xB0C00C58		DMA0_SASHDW49 00000000 00000000 00000000 00000000		
0xB0C00C5C		DMA0_DASHDW49 00000000 00000000 00000000 00000000		
0xB0C00C60- B0C00C7C		reserved XXXXXXXX XXXXXXXX XXXXXXXX XXXXXXXX		
0xB0C00C80		DMA0_A50 00000000 00001111 00000000 00000000		
0xB0C00C84		DMA0_B50 00000000 00000000 00110011 01111111		
0xB0C00C88		DMA0_SA50 00000000 00000000 00000000 00000000		
0xB0C00C8C		DMA0_DA50 00000000 00000000 00000000 00000000		
0xB0C00C90		DMA0_C50 XXXXXXXX XXXXXXXX 00000000 00000000		
0xB0C00C94		DMA0_D50 00000000 XXXXXXXX 00000000 XXXXXXXX		
0xB0C00C98		DMA0_SASHDW50 00000000 00000000 00000000 00000000		
0xB0C00C9C		DMA0_DASHDW50 00000000 00000000 00000000 00000000		
0xB0C00CA0- B0C00CBC		reserved XXXXXXXX XXXXXXXX XXXXXXXX XXXXXXXX		
0xB0C00CC0		DMA0_A51 00000000 00001111 00000000 00000000		
0xB0C00CC4		DMA0_B51 00000000 00000000 00110011 01111111		
0xB0C00CC8		DMA0_SA51 00000000 00000000 00000000 00000000		
0xB0C00CCC		DMA0_DA51 00000000 00000000 00000000 00000000		
0xB0C00CD0		DMA0_C51 XXXXXXXX XXXXXXXX 00000000 00000000		
0xB0C00CD4		DMA0_D51 00000000 XXXXXXXX 00000000 XXXXXXXX		
0xB0C00CD8		DMA0_SASHDW51 00000000 00000000 00000000 00000000		
0xB0C00CDC		DMA0_DASHDW51 00000000 00000000 00000000 00000000		
0xB0C00CE0- B0C00CFC		reserved XXXXXXXX XXXXXXXX XXXXXXXX XXXXXXXX		

Table 39. Memory Layout of PERI5_AHB Registers with Default Values (Continued)

Offset	+3	+2	+1	+0
0xB0C00D00		DMA0_A52 00000000 00001111 00000000 00000000		
0xB0C00D04		DMA0_B52 00000000 00000000 00110011 01111111		
0xB0C00D08		DMA0_SA52 00000000 00000000 00000000 00000000		
0xB0C00D0C		DMA0_DA52 00000000 00000000 00000000 00000000		
0xB0C00D10		DMA0_C52 XXXXXXXX XXXXXXXX 00000000 00000000		
0xB0C00D14		DMA0_D52 00000000 XXXXXXXX 00000000 XXXXXXXX		
0xB0C00D18		DMA0_SASHDW52 00000000 00000000 00000000 00000000		
0xB0C00D1C		DMA0_DASHDW52 00000000 00000000 00000000 00000000		
0xB0C00D20- B0C00D3C		reserved XXXXXXXX XXXXXXXX XXXXXXXX XXXXXXXX		
0xB0C00D40		DMA0_A53 00000000 00001111 00000000 00000000		
0xB0C00D44		DMA0_B53 00000000 00000000 00110011 01111111		
0xB0C00D48		DMA0_SA53 00000000 00000000 00000000 00000000		
0xB0C00D4C		DMA0_DA53 00000000 00000000 00000000 00000000		
0xB0C00D50		DMA0_C53 XXXXXXXX XXXXXXXX 00000000 00000000		
0xB0C00D54		DMA0_D53 00000000 XXXXXXXX 00000000 XXXXXXXX		
0xB0C00D58		DMA0_SASHDW53 00000000 00000000 00000000 00000000		
0xB0C00D5C		DMA0_DASHDW53 00000000 00000000 00000000 00000000		
0xB0C00D60- B0C00D7C		reserved XXXXXXXX XXXXXXXX XXXXXXXX XXXXXXXX		
0xB0C00D80		DMA0_A54 00000000 00001111 00000000 00000000		
0xB0C00D84		DMA0_B54 00000000 00000000 00110011 01111111		
0xB0C00D88		DMA0_SA54 00000000 00000000 00000000 00000000		
0xB0C00D8C		DMA0_DA54 00000000 00000000 00000000 00000000		
0xB0C00D90		DMA0_C54 XXXXXXXX XXXXXXXX 00000000 00000000		
0xB0C00D94		DMA0_D54 00000000 XXXXXXXX 00000000 XXXXXXXX		
0xB0C00D98		DMA0_SASHDW54 00000000 00000000 00000000 00000000		
0xB0C00D9C		DMA0_DASHDW54 00000000 00000000 00000000 00000000		

Table 39. Memory Layout of PERI5_AHB Registers with Default Values (Continued)

Offset	+3	+2	+1	+0
0xB0C00DA0- B0C00DBC	reserved XXXXXXXX XXXXXXXX XXXXXXXX XXXXXXXX			
0xB0C00DC0	DMA0_A55 00000000 00001111 00000000 00000000			
0xB0C00DC4	DMA0_B55 00000000 00000000 00110011 01111111			
0xB0C00DC8	DMA0_SA55 00000000 00000000 00000000 00000000			
0xB0C00DCC	DMA0_DA55 00000000 00000000 00000000 00000000			
0xB0C00DD0	DMA0_C55 XXXXXXXX XXXXXXXX 00000000 00000000			
0xB0C00DD4	DMA0_D55 00000000 XXXXXXXX 00000000 XXXXXXXX			
0xB0C00DD8	DMA0_SASHDW55 00000000 00000000 00000000 00000000			
0xB0C00DDC	DMA0_DASHDW55 00000000 00000000 00000000 00000000			
0xB0C00DE0- B0C00DFC	reserved XXXXXXXX XXXXXXXX XXXXXXXX XXXXXXXX			
0xB0C00E00	DMA0_A56 00000000 00001111 00000000 00000000			
0xB0C00E04	DMA0_B56 00000000 00000000 00110011 01111111			
0xB0C00E08	DMA0_SA56 00000000 00000000 00000000 00000000			
0xB0C00E0C	DMA0_DA56 00000000 00000000 00000000 00000000			
0xB0C00E10	DMA0_C56 XXXXXXXX XXXXXXXX 00000000 00000000			
0xB0C00E14	DMA0_D56 00000000 XXXXXXXX 00000000 XXXXXXXX			
0xB0C00E18	DMA0_SASHDW56 00000000 00000000 00000000 00000000			
0xB0C00E1C	DMA0_DASHDW56 00000000 00000000 00000000 00000000			
0xB0C00E20- B0C00E3C	reserved XXXXXXXX XXXXXXXX XXXXXXXX XXXXXXXX			
0xB0C00E40	DMA0_A57 00000000 00001111 00000000 00000000			
0xB0C00E44	DMA0_B57 00000000 00000000 00110011 01111111			
0xB0C00E48	DMA0_SA57 00000000 00000000 00000000 00000000			
0xB0C00E4C	DMA0_DA57 00000000 00000000 00000000 00000000			
0xB0C00E50	DMA0_C57 XXXXXXXX XXXXXXXX 00000000 00000000			
0xB0C00E54	DMA0_D57 00000000 XXXXXXXX 00000000 XXXXXXXX			
0xB0C00E58	DMA0_SASHDW57 00000000 00000000 00000000 00000000			

Table 39. Memory Layout of PERI5_AHB Registers with Default Values (Continued)

Offset	+3	+2	+1	+0
0xB0C00E5C		DMA0_DASHDW57 00000000 00000000 00000000 00000000		
0xB0C00E60- B0C00E7C		reserved XXXXXXXX XXXXXXXX XXXXXXXX XXXXXXXX		
0xB0C00E80		DMA0_A58 00000000 00001111 00000000 00000000		
0xB0C00E84		DMA0_B58 00000000 00000000 00110011 01111111		
0xB0C00E88		DMA0_SA58 00000000 00000000 00000000 00000000		
0xB0C00E8C		DMA0_DA58 00000000 00000000 00000000 00000000		
0xB0C00E90		DMA0_C58 XXXXXXXX XXXXXXXX 00000000 00000000		
0xB0C00E94		DMA0_D58 00000000 XXXXXXXX 00000000 XXXXXXXX		
0xB0C00E98		DMA0_SASHDW58 00000000 00000000 00000000 00000000		
0xB0C00E9C		DMA0_DASHDW58 00000000 00000000 00000000 00000000		
0xB0C00EA0- B0C00EBC		reserved XXXXXXXX XXXXXXXX XXXXXXXX XXXXXXXX		
0xB0C00EC0		DMA0_A59 00000000 00001111 00000000 00000000		
0xB0C00EC4		DMA0_B59 00000000 00000000 00110011 01111111		
0xB0C00EC8		DMA0_SA59 00000000 00000000 00000000 00000000		
0xB0C00ECC		DMA0_DA59 00000000 00000000 00000000 00000000		
0xB0C00ED0		DMA0_C59 XXXXXXXX XXXXXXXX 00000000 00000000		
0xB0C00ED4		DMA0_D59 00000000 XXXXXXXX 00000000 XXXXXXXX		
0xB0C00ED8		DMA0_SASHDW59 00000000 00000000 00000000 00000000		
0xB0C00EDC		DMA0_DASHDW59 00000000 00000000 00000000 00000000		
0xB0C00EE0- B0C00EFC		reserved XXXXXXXX XXXXXXXX XXXXXXXX XXXXXXXX		
0xB0C00F00		DMA0_A60 00000000 00001111 00000000 00000000		
0xB0C00F04		DMA0_B60 00000000 00000000 00110011 01111111		
0xB0C00F08		DMA0_SA60 00000000 00000000 00000000 00000000		
0xB0C00F0C		DMA0_DA60 00000000 00000000 00000000 00000000		
0xB0C00F10		DMA0_C60 XXXXXXXX XXXXXXXX 00000000 00000000		
0xB0C00F14		DMA0_D60 00000000 XXXXXXXX 00000000 XXXXXXXX		

Table 39. Memory Layout of PERI5_AHB Registers with Default Values (Continued)

Offset	+3	+2	+1	+0
0xB0C00F18		DMA0_SASHDW60 00000000 00000000 00000000 00000000		
0xB0C00F1C		DMA0_DASHDW60 00000000 00000000 00000000 00000000		
0xB0C00F20- B0C00F3C		reserved XXXXXXXX XXXXXXXX XXXXXXXX XXXXXXXX		
0xB0C00F40		DMA0_A61 00000000 00001111 00000000 00000000		
0xB0C00F44		DMA0_B61 00000000 00000000 00110011 01111111		
0xB0C00F48		DMA0_SA61 00000000 00000000 00000000 00000000		
0xB0C00F4C		DMA0_DA61 00000000 00000000 00000000 00000000		
0xB0C00F50		DMA0_C61 XXXXXXXX XXXXXXXX 00000000 00000000		
0xB0C00F54		DMA0_D61 00000000 XXXXXXXX 00000000 XXXXXXXX		
0xB0C00F58		DMA0_SASHDW61 00000000 00000000 00000000 00000000		
0xB0C00F5C		DMA0_DASHDW61 00000000 00000000 00000000 00000000		
0xB0C00F60- B0C00F7C		reserved XXXXXXXX XXXXXXXX XXXXXXXX XXXXXXXX		
0xB0C00F80		DMA0_A62 00000000 00001111 00000000 00000000		
0xB0C00F84		DMA0_B62 00000000 00000000 00110011 01111111		
0xB0C00F88		DMA0_SA62 00000000 00000000 00000000 00000000		
0xB0C00F8C		DMA0_DA62 00000000 00000000 00000000 00000000		
0xB0C00F90		DMA0_C62 XXXXXXXX XXXXXXXX 00000000 00000000		
0xB0C00F94		DMA0_D62 00000000 XXXXXXXX 00000000 XXXXXXXX		
0xB0C00F98		DMA0_SASHDW62 00000000 00000000 00000000 00000000		
0xB0C00F9C		DMA0_DASHDW62 00000000 00000000 00000000 00000000		
0xB0C00FA0- B0C00FBC		reserved XXXXXXXX XXXXXXXX XXXXXXXX XXXXXXXX		
0xB0C00FC0		DMA0_A63 00000000 00001111 00000000 00000000		
0xB0C00FC4		DMA0_B63 00000000 00000000 00110011 01111111		
0xB0C00FC8		DMA0_SA63 00000000 00000000 00000000 00000000		
0xB0C00FCC		DMA0_DA63 00000000 00000000 00000000 00000000		
0xB0C00FD0		DMA0_C63 XXXXXXXX XXXXXXXX 00000000 00000000		

Table 39. Memory Layout of PERI5_AHB Registers with Default Values (Continued)

Offset	+3	+2	+1	+0
0xB0C00FD4		DMA0_D63 00000000 XXXXXXXX 00000000 XXXXXXXX		
0xB0C00FD8		DMA0_SASHDW63 00000000 00000000 00000000 00000000		
0xB0C00FDC		DMA0_DASHDW63 00000000 00000000 00000000 00000000		
0xB0C00FE0- B0C00FFC		reserved XXXXXXXX XXXXXXXX XXXXXXXX XXXXXXXX		
0xB0C01000		DMA0_R 01000000 XXXXXXXX XXXXXXXX 00000001		
0xB0C01004		DMA0_DIRQ1 00000000 00000000 00000000 00000000		
0xB0C01008		DMA0_DIRQ2 00000000 00000000 00000000 00000000		
0xB0C0100C		DMA0_EDIRQ1 00000000 00000000 00000000 00000000		
0xB0C01010		DMA0_EDIRQ2 00000000 00000000 00000000 00000000		
0xB0C01014		DMA0_ID 00000000 00000000 00000000 00000000		
0xB0C01018- B0C01FFC		reserved XXXXXXXX XXXXXXXX XXXXXXXX XXXXXXXX		
0xB0C02000		DMA0_CMECIC0 00000000 00000000 XXXXXXXX 00000000		
0xB0C02004		DMA0_CMECIC1 00000000 00000000 XXXXXXXX 00000000		
0xB0C02008		DMA0_CMECIC2 00000000 00000000 XXXXXXXX 00000000		
0xB0C0200C		DMA0_CMECIC3 00000000 00000000 XXXXXXXX 00000000		
0xB0C02010		DMA0_CMECIC4 00000000 00000000 XXXXXXXX 00000000		
0xB0C02014		DMA0_CMECIC5 00000000 00000000 XXXXXXXX 00000000		
0xB0C02018		DMA0_CMECIC6 00000000 00000000 XXXXXXXX 00000000		
0xB0C0201C		DMA0_CMECIC7 00000000 00000000 XXXXXXXX 00000000		
0xB0C02020		DMA0_CMICIC0 00000000 XXXXXXXX XXXXXXXX XXXXXXXX		
0xB0C02024		DMA0_CMICIC1 00000000 XXXXXXXX XXXXXXXX XXXXXXXX		
0xB0C02028		DMA0_CMICIC2 00000000 XXXXXXXX XXXXXXXX XXXXXXXX		
0xB0C0202C		DMA0_CMICIC3 00000000 XXXXXXXX XXXXXXXX XXXXXXXX		
0xB0C02030		DMA0_CMICIC4 00000000 XXXXXXXX XXXXXXXX XXXXXXXX		
0xB0C02034		DMA0_CMICIC5 00000000 XXXXXXXX XXXXXXXX XXXXXXXX		
0xB0C02038		DMA0_CMICIC6 00000000 XXXXXXXX XXXXXXXX XXXXXXXX		

Table 39. Memory Layout of PERI5_AHB Registers with Default Values (Continued)

Offset	+3	+2	+1	+0
0xB0C0203C		DMA0_CMICIC7 00000000 XXXXXXXX XXXXXXXX XXXXXXXX		
0xB0C02040		DMA0_CMICIC8 00000000 XXXXXXXX XXXXXXXX XXXXXXXX		
0xB0C02044		DMA0_CMICIC9 00000000 XXXXXXXX XXXXXXXX XXXXXXXX		
0xB0C02048		DMA0_CMICIC10 00000000 XXXXXXXX XXXXXXXX XXXXXXXX		
0xB0C0204C		DMA0_CMICIC11 00000000 XXXXXXXX XXXXXXXX XXXXXXXX		
0xB0C02050		DMA0_CMICIC12 00000000 XXXXXXXX XXXXXXXX XXXXXXXX		
0xB0C02054		DMA0_CMICIC13 00000000 XXXXXXXX XXXXXXXX XXXXXXXX		
0xB0C02058		DMA0_CMICIC14 00000000 XXXXXXXX XXXXXXXX XXXXXXXX		
0xB0C0205C		DMA0_CMICIC15 00000000 XXXXXXXX XXXXXXXX XXXXXXXX		
0xB0C02060		DMA0_CMICIC16 00000000 XXXXXXXX XXXXXXXX XXXXXXXX		
0xB0C02064		DMA0_CMICIC17 00000000 XXXXXXXX XXXXXXXX XXXXXXXX		
0xB0C02068		DMA0_CMICIC18 00000000 XXXXXXXX XXXXXXXX XXXXXXXX		
0xB0C0206C		DMA0_CMICIC19 00000000 XXXXXXXX XXXXXXXX XXXXXXXX		
0xB0C02070		DMA0_CMICIC20 00000000 XXXXXXXX XXXXXXXX XXXXXXXX		
0xB0C02074		DMA0_CMICIC21 00000000 XXXXXXXX XXXXXXXX XXXXXXXX		
0xB0C02078		DMA0_CMICIC22 00000000 XXXXXXXX XXXXXXXX XXXXXXXX		
0xB0C0207C		DMA0_CMICIC23 00000000 XXXXXXXX XXXXXXXX XXXXXXXX		
0xB0C02080		DMA0_CMICIC24 00000000 XXXXXXXX XXXXXXXX XXXXXXXX		
0xB0C02084		DMA0_CMICIC25 00000000 XXXXXXXX XXXXXXXX XXXXXXXX		
0xB0C02088		DMA0_CMICIC26 00000000 XXXXXXXX XXXXXXXX XXXXXXXX		
0xB0C0208C		DMA0_CMICIC27 00000000 XXXXXXXX XXXXXXXX XXXXXXXX		
0xB0C02090		DMA0_CMICIC28 00000000 XXXXXXXX XXXXXXXX XXXXXXXX		
0xB0C02094		DMA0_CMICIC29 00000000 XXXXXXXX XXXXXXXX XXXXXXXX		
0xB0C02098		DMA0_CMICIC30 00000000 XXXXXXXX XXXXXXXX XXXXXXXX		
0xB0C0209C		DMA0_CMICIC31 00000000 XXXXXXXX XXXXXXXX XXXXXXXX		
0xB0C020A0		DMA0_CMICIC32 00000000 XXXXXXXX XXXXXXXX XXXXXXXX		

Table 39. Memory Layout of PERI5_AHB Registers with Default Values (Continued)

Offset	+3	+2	+1	+0
0xB0C020A4		DMA0_CMICIC33 00000000 XXXXXXXX XXXXXXXX XXXXXXXX		
0xB0C020A8		DMA0_CMICIC34 00000000 XXXXXXXX XXXXXXXX XXXXXXXX		
0xB0C020AC		DMA0_CMICIC35 00000000 XXXXXXXX XXXXXXXX XXXXXXXX		
0xB0C020B0		DMA0_CMICIC36 00000000 XXXXXXXX XXXXXXXX XXXXXXXX		
0xB0C020B4		DMA0_CMICIC37 00000000 XXXXXXXX XXXXXXXX XXXXXXXX		
0xB0C020B8		DMA0_CMICIC38 00000000 XXXXXXXX XXXXXXXX XXXXXXXX		
0xB0C020BC		DMA0_CMICIC39 00000000 XXXXXXXX XXXXXXXX XXXXXXXX		
0xB0C020C0		DMA0_CMICIC40 00000000 XXXXXXXX XXXXXXXX XXXXXXXX		
0xB0C020C4		DMA0_CMICIC41 00000000 XXXXXXXX XXXXXXXX XXXXXXXX		
0xB0C020C8		DMA0_CMICIC42 00000000 XXXXXXXX XXXXXXXX XXXXXXXX		
0xB0C020CC		DMA0_CMICIC43 00000000 XXXXXXXX XXXXXXXX XXXXXXXX		
0xB0C020D0		DMA0_CMICIC44 00000000 XXXXXXXX XXXXXXXX XXXXXXXX		
0xB0C020D4		DMA0_CMICIC45 00000000 XXXXXXXX XXXXXXXX XXXXXXXX		
0xB0C020D8		DMA0_CMICIC46 00000000 XXXXXXXX XXXXXXXX XXXXXXXX		
0xB0C020DC		DMA0_CMICIC47 00000000 XXXXXXXX XXXXXXXX XXXXXXXX		
0xB0C020E0		DMA0_CMICIC48 00000000 XXXXXXXX XXXXXXXX XXXXXXXX		
0xB0C020E4		DMA0_CMICIC49 00000000 XXXXXXXX XXXXXXXX XXXXXXXX		
0xB0C020E8		DMA0_CMICIC50 00000000 XXXXXXXX XXXXXXXX XXXXXXXX		
0xB0C020EC		DMA0_CMICIC51 00000000 XXXXXXXX XXXXXXXX XXXXXXXX		
0xB0C020F0		DMA0_CMICIC52 00000000 XXXXXXXX XXXXXXXX XXXXXXXX		
0xB0C020F4		DMA0_CMICIC53 00000000 XXXXXXXX XXXXXXXX XXXXXXXX		
0xB0C020F8		DMA0_CMICIC54 00000000 XXXXXXXX XXXXXXXX XXXXXXXX		
0xB0C020FC		DMA0_CMICIC55 00000000 XXXXXXXX XXXXXXXX XXXXXXXX		
0xB0C02100		DMA0_CMICIC56 00000000 XXXXXXXX XXXXXXXX XXXXXXXX		
0xB0C02104		DMA0_CMICIC57 00000000 XXXXXXXX XXXXXXXX XXXXXXXX		
0xB0C02108		DMA0_CMICIC58 00000000 XXXXXXXX XXXXXXXX XXXXXXXX		

Table 39. Memory Layout of PERI5_AHB Registers with Default Values (Continued)

Offset	+3	+2	+1	+0
0xB0C0210C		DMA0_CMICIC59 00000000 XXXXXXXX XXXXXXXX XXXXXXXX		
0xB0C02110		DMA0_CMICIC60 00000000 XXXXXXXX XXXXXXXX XXXXXXXX		
0xB0C02114		DMA0_CMICIC61 00000000 XXXXXXXX XXXXXXXX XXXXXXXX		
0xB0C02118		DMA0_CMICIC62 00000000 XXXXXXXX XXXXXXXX XXXXXXXX		
0xB0C0211C		DMA0_CMICIC63 00000000 XXXXXXXX XXXXXXXX XXXXXXXX		
0xB0C02120		DMA0_CMICIC64 00000000 XXXXXXXX XXXXXXXX XXXXXXXX		
0xB0C02124		DMA0_CMICIC65 00000000 XXXXXXXX XXXXXXXX XXXXXXXX		
0xB0C02128		DMA0_CMICIC66 00000000 XXXXXXXX XXXXXXXX XXXXXXXX		
0xB0C0212C		DMA0_CMICIC67 00000000 XXXXXXXX XXXXXXXX XXXXXXXX		
0xB0C02130		DMA0_CMICIC68 00000000 XXXXXXXX XXXXXXXX XXXXXXXX		
0xB0C02134		DMA0_CMICIC69 00000000 XXXXXXXX XXXXXXXX XXXXXXXX		
0xB0C02138		DMA0_CMICIC70 00000000 XXXXXXXX XXXXXXXX XXXXXXXX		
0xB0C0213C		DMA0_CMICIC71 00000000 XXXXXXXX XXXXXXXX XXXXXXXX		
0xB0C02140		DMA0_CMICIC72 00000000 XXXXXXXX XXXXXXXX XXXXXXXX		
0xB0C02144		DMA0_CMICIC73 00000000 XXXXXXXX XXXXXXXX XXXXXXXX		
0xB0C02148		DMA0_CMICIC74 00000000 XXXXXXXX XXXXXXXX XXXXXXXX		
0xB0C0214C		DMA0_CMICIC75 00000000 XXXXXXXX XXXXXXXX XXXXXXXX		
0xB0C02150		DMA0_CMICIC76 00000000 XXXXXXXX XXXXXXXX XXXXXXXX		
0xB0C02154		DMA0_CMICIC77 00000000 XXXXXXXX XXXXXXXX XXXXXXXX		
0xB0C02158		DMA0_CMICIC78 00000000 XXXXXXXX XXXXXXXX XXXXXXXX		
0xB0C0215C		DMA0_CMICIC79 00000000 XXXXXXXX XXXXXXXX XXXXXXXX		
0xB0C02160		DMA0_CMICIC80 00000000 XXXXXXXX XXXXXXXX XXXXXXXX		
0xB0C02164		DMA0_CMICIC81 00000000 XXXXXXXX XXXXXXXX XXXXXXXX		
0xB0C02168		DMA0_CMICIC82 00000000 XXXXXXXX XXXXXXXX XXXXXXXX		
0xB0C0216C		DMA0_CMICIC83 00000000 XXXXXXXX XXXXXXXX XXXXXXXX		
0xB0C02170		DMA0_CMICIC84 00000000 XXXXXXXX XXXXXXXX XXXXXXXX		

Table 39. Memory Layout of PERI5_AHB Registers with Default Values (Continued)

Offset	+3	+2	+1	+0
0xB0C02174		DMA0_CMICIC85 00000000 XXXXXXXX XXXXXXXX XXXXXXXX		
0xB0C02178		DMA0_CMICIC86 00000000 XXXXXXXX XXXXXXXX XXXXXXXX		
0xB0C0217C		DMA0_CMICIC87 00000000 XXXXXXXX XXXXXXXX XXXXXXXX		
0xB0C02180		DMA0_CMICIC88 00000000 XXXXXXXX XXXXXXXX XXXXXXXX		
0xB0C02184		DMA0_CMICIC89 00000000 XXXXXXXX XXXXXXXX XXXXXXXX		
0xB0C02188		DMA0_CMICIC90 00000000 XXXXXXXX XXXXXXXX XXXXXXXX		
0xB0C0218C		DMA0_CMICIC91 00000000 XXXXXXXX XXXXXXXX XXXXXXXX		
0xB0C02190		DMA0_CMICIC92 00000000 XXXXXXXX XXXXXXXX XXXXXXXX		
0xB0C02194		DMA0_CMICIC93 00000000 XXXXXXXX XXXXXXXX XXXXXXXX		
0xB0C02198		DMA0_CMICIC94 00000000 XXXXXXXX XXXXXXXX XXXXXXXX		
0xB0C0219C		DMA0_CMICIC95 00000000 XXXXXXXX XXXXXXXX XXXXXXXX		
0xB0C021A0		DMA0_CMICIC96 00000000 XXXXXXXX XXXXXXXX XXXXXXXX		
0xB0C021A4		DMA0_CMICIC97 00000000 XXXXXXXX XXXXXXXX XXXXXXXX		
0xB0C021A8		DMA0_CMICIC98 00000000 XXXXXXXX XXXXXXXX XXXXXXXX		
0xB0C021AC		DMA0_CMICIC99 00000000 XXXXXXXX XXXXXXXX XXXXXXXX		
0xB0C021B0		DMA0_CMICIC100 00000000 XXXXXXXX XXXXXXXX XXXXXXXX		
0xB0C021B4		DMA0_CMICIC101 00000000 XXXXXXXX XXXXXXXX XXXXXXXX		
0xB0C021B8		DMA0_CMICIC102 00000000 XXXXXXXX XXXXXXXX XXXXXXXX		
0xB0C021BC		DMA0_CMICIC103 00000000 XXXXXXXX XXXXXXXX XXXXXXXX		
0xB0C021C0		DMA0_CMICIC104 00000000 XXXXXXXX XXXXXXXX XXXXXXXX		
0xB0C021C4		DMA0_CMICIC105 00000000 XXXXXXXX XXXXXXXX XXXXXXXX		
0xB0C021C8		DMA0_CMICIC106 00000000 XXXXXXXX XXXXXXXX XXXXXXXX		
0xB0C021CC		DMA0_CMICIC107 00000000 XXXXXXXX XXXXXXXX XXXXXXXX		
0xB0C021D0		DMA0_CMICIC108 00000000 XXXXXXXX XXXXXXXX XXXXXXXX		
0xB0C021D4		DMA0_CMICIC109 00000000 XXXXXXXX XXXXXXXX XXXXXXXX		
0xB0C021D8		DMA0_CMICIC110 00000000 XXXXXXXX XXXXXXXX XXXXXXXX		

Table 39. Memory Layout of PERI5_AHB Registers with Default Values (Continued)

Offset	+3	+2	+1	+0
0xB0C021DC		DMA0_CMICIC111 00000000 XXXXXXXX XXXXXXXX XXXXXXXX		
0xB0C021E0		DMA0_CMICIC112 00000000 XXXXXXXX XXXXXXXX XXXXXXXX		
0xB0C021E4		DMA0_CMICIC113 00000000 XXXXXXXX XXXXXXXX XXXXXXXX		
0xB0C021E8		DMA0_CMICIC114 00000000 XXXXXXXX XXXXXXXX XXXXXXXX		
0xB0C021EC		DMA0_CMICIC115 00000000 XXXXXXXX XXXXXXXX XXXXXXXX		
0xB0C021F0		DMA0_CMICIC116 00000000 XXXXXXXX XXXXXXXX XXXXXXXX		
0xB0C021F4		DMA0_CMICIC117 00000000 XXXXXXXX XXXXXXXX XXXXXXXX		
0xB0C021F8		DMA0_CMICIC118 00000000 XXXXXXXX XXXXXXXX XXXXXXXX		
0xB0C021FC		DMA0_CMICIC119 00000000 XXXXXXXX XXXXXXXX XXXXXXXX		
0xB0C02200		DMA0_CMICIC120 00000000 XXXXXXXX XXXXXXXX XXXXXXXX		
0xB0C02204		DMA0_CMICIC121 00000000 XXXXXXXX XXXXXXXX XXXXXXXX		
0xB0C02208		DMA0_CMICIC122 00000000 XXXXXXXX XXXXXXXX XXXXXXXX		
0xB0C0220C		DMA0_CMICIC123 00000000 XXXXXXXX XXXXXXXX XXXXXXXX		
0xB0C02210		DMA0_CMICIC124 00000000 XXXXXXXX XXXXXXXX XXXXXXXX		
0xB0C02214		DMA0_CMICIC125 00000000 XXXXXXXX XXXXXXXX XXXXXXXX		
0xB0C02218		DMA0_CMICIC126 00000000 XXXXXXXX XXXXXXXX XXXXXXXX		
0xB0C0221C		DMA0_CMICIC127 00000000 XXXXXXXX XXXXXXXX XXXXXXXX		
0xB0C02220		DMA0_CMICIC128 00000000 XXXXXXXX XXXXXXXX XXXXXXXX		
0xB0C02224		DMA0_CMICIC129 00000000 XXXXXXXX XXXXXXXX XXXXXXXX		
0xB0C02228		DMA0_CMICIC130 00000000 XXXXXXXX XXXXXXXX XXXXXXXX		
0xB0C0222C		DMA0_CMICIC131 00000000 XXXXXXXX XXXXXXXX XXXXXXXX		
0xB0C02230		DMA0_CMICIC132 00000000 XXXXXXXX XXXXXXXX XXXXXXXX		
0xB0C02234		DMA0_CMICIC133 00000000 XXXXXXXX XXXXXXXX XXXXXXXX		
0xB0C02238		DMA0_CMICIC134 00000000 XXXXXXXX XXXXXXXX XXXXXXXX		
0xB0C0223C		DMA0_CMICIC135 00000000 XXXXXXXX XXXXXXXX XXXXXXXX		
0xB0C02240		DMA0_CMICIC136 00000000 XXXXXXXX XXXXXXXX XXXXXXXX		

Table 39. Memory Layout of PERI5_AHB Registers with Default Values (Continued)

Offset	+3	+2	+1	+0
0xB0C02244		DMA0_CMICIC137 00000000 XXXXXXXX XXXXXXXX XXXXXXXX		
0xB0C02248		DMA0_CMICIC138 00000000 XXXXXXXX XXXXXXXX XXXXXXXX		
0xB0C0224C		DMA0_CMICIC139 00000000 XXXXXXXX XXXXXXXX XXXXXXXX		
0xB0C02250		DMA0_CMICIC140 00000000 XXXXXXXX XXXXXXXX XXXXXXXX		
0xB0C02254		DMA0_CMICIC141 00000000 XXXXXXXX XXXXXXXX XXXXXXXX		
0xB0C02258		DMA0_CMICIC142 00000000 XXXXXXXX XXXXXXXX XXXXXXXX		
0xB0C0225C		DMA0_CMICIC143 00000000 XXXXXXXX XXXXXXXX XXXXXXXX		
0xB0C02260		DMA0_CMICIC144 00000000 XXXXXXXX XXXXXXXX XXXXXXXX		
0xB0C02264		DMA0_CMICIC145 00000000 XXXXXXXX XXXXXXXX XXXXXXXX		
0xB0C02268		DMA0_CMICIC146 00000000 XXXXXXXX XXXXXXXX XXXXXXXX		
0xB0C0226C		DMA0_CMICIC147 00000000 XXXXXXXX XXXXXXXX XXXXXXXX		
0xB0C02270		DMA0_CMICIC148 00000000 XXXXXXXX XXXXXXXX XXXXXXXX		
0xB0C02274		DMA0_CMICIC149 00000000 XXXXXXXX XXXXXXXX XXXXXXXX		
0xB0C02278		DMA0_CMICIC150 00000000 XXXXXXXX XXXXXXXX XXXXXXXX		
0xB0C0227C		DMA0_CMICIC151 00000000 XXXXXXXX XXXXXXXX XXXXXXXX		
0xB0C02280		DMA0_CMICIC152 00000000 XXXXXXXX XXXXXXXX XXXXXXXX		
0xB0C02284		DMA0_CMICIC153 00000000 XXXXXXXX XXXXXXXX XXXXXXXX		
0xB0C02288		DMA0_CMICIC154 00000000 XXXXXXXX XXXXXXXX XXXXXXXX		
0xB0C0228C		DMA0_CMICIC155 00000000 XXXXXXXX XXXXXXXX XXXXXXXX		
0xB0C02290		DMA0_CMICIC156 00000000 XXXXXXXX XXXXXXXX XXXXXXXX		
0xB0C02294		DMA0_CMICIC157 00000000 XXXXXXXX XXXXXXXX XXXXXXXX		
0xB0C02298		DMA0_CMICIC158 00000000 XXXXXXXX XXXXXXXX XXXXXXXX		
0xB0C0229C		DMA0_CMICIC159 00000000 XXXXXXXX XXXXXXXX XXXXXXXX		
0xB0C022A0		DMA0_CMICIC160 00000000 XXXXXXXX XXXXXXXX XXXXXXXX		
0xB0C022A4		DMA0_CMICIC161 00000000 XXXXXXXX XXXXXXXX XXXXXXXX		
0xB0C022A8		DMA0_CMICIC162 00000000 XXXXXXXX XXXXXXXX XXXXXXXX		

Table 39. Memory Layout of PERI5_AHB Registers with Default Values (Continued)

Offset	+3	+2	+1	+0
0xB0C022AC		DMA0_CMICIC163 00000000 XXXXXXXX XXXXXXXX XXXXXXXX		
0xB0C022B0		DMA0_CMICIC164 00000000 XXXXXXXX XXXXXXXX XXXXXXXX		
0xB0C022B4		DMA0_CMICIC165 00000000 XXXXXXXX XXXXXXXX XXXXXXXX		
0xB0C022B8		DMA0_CMICIC166 00000000 XXXXXXXX XXXXXXXX XXXXXXXX		
0xB0C022BC		DMA0_CMICIC167 00000000 XXXXXXXX XXXXXXXX XXXXXXXX		
0xB0C022C0		DMA0_CMICIC168 00000000 XXXXXXXX XXXXXXXX XXXXXXXX		
0xB0C022C4		DMA0_CMICIC169 00000000 XXXXXXXX XXXXXXXX XXXXXXXX		
0xB0C022C8		DMA0_CMICIC170 00000000 XXXXXXXX XXXXXXXX XXXXXXXX		
0xB0C022CC		DMA0_CMICIC171 00000000 XXXXXXXX XXXXXXXX XXXXXXXX		
0xB0C022D0		DMA0_CMICIC172 00000000 XXXXXXXX XXXXXXXX XXXXXXXX		
0xB0C022D4		DMA0_CMICIC173 00000000 XXXXXXXX XXXXXXXX XXXXXXXX		
0xB0C022D8		DMA0_CMICIC174 00000000 XXXXXXXX XXXXXXXX XXXXXXXX		
0xB0C022DC		DMA0_CMICIC175 00000000 XXXXXXXX XXXXXXXX XXXXXXXX		
0xB0C022E0		DMA0_CMICIC176 00000000 XXXXXXXX XXXXXXXX XXXXXXXX		
0xB0C022E4		DMA0_CMICIC177 00000000 XXXXXXXX XXXXXXXX XXXXXXXX		
0xB0C022E8		DMA0_CMICIC178 00000000 XXXXXXXX XXXXXXXX XXXXXXXX		
0xB0C022EC		DMA0_CMICIC179 00000000 XXXXXXXX XXXXXXXX XXXXXXXX		
0xB0C022F0		DMA0_CMICIC180 00000000 XXXXXXXX XXXXXXXX XXXXXXXX		
0xB0C022F4		DMA0_CMICIC181 00000000 XXXXXXXX XXXXXXXX XXXXXXXX		
0xB0C022F8		DMA0_CMICIC182 00000000 XXXXXXXX XXXXXXXX XXXXXXXX		
0xB0C022FC		DMA0_CMICIC183 00000000 XXXXXXXX XXXXXXXX XXXXXXXX		
0xB0C02300		DMA0_CMICIC184 00000000 XXXXXXXX XXXXXXXX XXXXXXXX		
0xB0C02304		DMA0_CMICIC185 00000000 XXXXXXXX XXXXXXXX XXXXXXXX		
0xB0C02308		DMA0_CMICIC186 00000000 XXXXXXXX XXXXXXXX XXXXXXXX		
0xB0C0230C		DMA0_CMICIC187 00000000 XXXXXXXX XXXXXXXX XXXXXXXX		
0xB0C02310		DMA0_CMICIC188 00000000 XXXXXXXX XXXXXXXX XXXXXXXX		

Table 39. Memory Layout of PERI5_AHB Registers with Default Values (Continued)

Offset	+3	+2	+1	+0
0xB0C02314		DMA0_CMICIC189 00000000 XXXXXXXX XXXXXXXX XXXXXXXX		
0xB0C02318		DMA0_CMICIC190 00000000 XXXXXXXX XXXXXXXX XXXXXXXX		
0xB0C0231C		DMA0_CMICIC191 00000000 XXXXXXXX XXXXXXXX XXXXXXXX		
0xB0C02320		DMA0_CMICIC192 00000000 XXXXXXXX XXXXXXXX XXXXXXXX		
0xB0C02324		DMA0_CMICIC193 00000000 XXXXXXXX XXXXXXXX XXXXXXXX		
0xB0C02328		DMA0_CMICIC194 00000000 XXXXXXXX XXXXXXXX XXXXXXXX		
0xB0C0232C		DMA0_CMICIC195 00000000 XXXXXXXX XXXXXXXX XXXXXXXX		
0xB0C02330		DMA0_CMICIC196 00000000 XXXXXXXX XXXXXXXX XXXXXXXX		
0xB0C02334		DMA0_CMICIC197 00000000 XXXXXXXX XXXXXXXX XXXXXXXX		
0xB0C02338		DMA0_CMICIC198 00000000 XXXXXXXX XXXXXXXX XXXXXXXX		
0xB0C0233C		DMA0_CMICIC199 00000000 XXXXXXXX XXXXXXXX XXXXXXXX		
0xB0C02340		DMA0_CMICIC200 00000000 XXXXXXXX XXXXXXXX XXXXXXXX		
0xB0C02344		DMA0_CMICIC201 00000000 XXXXXXXX XXXXXXXX XXXXXXXX		
0xB0C02348		DMA0_CMICIC202 00000000 XXXXXXXX XXXXXXXX XXXXXXXX		
0xB0C0234C		DMA0_CMICIC203 00000000 XXXXXXXX XXXXXXXX XXXXXXXX		
0xB0C02350		DMA0_CMICIC204 00000000 XXXXXXXX XXXXXXXX XXXXXXXX		
0xB0C02354		DMA0_CMICIC205 00000000 XXXXXXXX XXXXXXXX XXXXXXXX		
0xB0C02358		DMA0_CMICIC206 00000000 XXXXXXXX XXXXXXXX XXXXXXXX		
0xB0C0235C		DMA0_CMICIC207 00000000 XXXXXXXX XXXXXXXX XXXXXXXX		
0xB0C02360		DMA0_CMICIC208 00000000 XXXXXXXX XXXXXXXX XXXXXXXX		
0xB0C02364		DMA0_CMICIC209 00000000 XXXXXXXX XXXXXXXX XXXXXXXX		
0xB0C02368		DMA0_CMICIC210 00000000 XXXXXXXX XXXXXXXX XXXXXXXX		
0xB0C0236C		DMA0_CMICIC211 00000000 XXXXXXXX XXXXXXXX XXXXXXXX		
0xB0C02370		DMA0_CMICIC212 00000000 XXXXXXXX XXXXXXXX XXXXXXXX		
0xB0C02374		DMA0_CMICIC213 00000000 XXXXXXXX XXXXXXXX XXXXXXXX		
0xB0C02378		DMA0_CMICIC214 00000000 XXXXXXXX XXXXXXXX XXXXXXXX		

Table 39. Memory Layout of PERI5_AHB Registers with Default Values (Continued)

Offset	+3	+2	+1	+0
0xB0C0237C		DMA0_CMICIC215 00000000 XXXXXXXX XXXXXXXX XXXXXXXX		
0xB0C02380		DMA0_CMICIC216 00000000 XXXXXXXX XXXXXXXX XXXXXXXX		
0xB0C02384		DMA0_CMICIC217 00000000 XXXXXXXX XXXXXXXX XXXXXXXX		
0xB0C02388		DMA0_CMICIC218 00000000 XXXXXXXX XXXXXXXX XXXXXXXX		
0xB0C0238C		DMA0_CMICIC219 00000000 XXXXXXXX XXXXXXXX XXXXXXXX		
0xB0C02390		DMA0_CMICIC220 00000000 XXXXXXXX XXXXXXXX XXXXXXXX		
0xB0C02394		DMA0_CMICIC221 00000000 XXXXXXXX XXXXXXXX XXXXXXXX		
0xB0C02398		DMA0_CMICIC222 00000000 XXXXXXXX XXXXXXXX XXXXXXXX		
0xB0C0239C		DMA0_CMICIC223 00000000 XXXXXXXX XXXXXXXX XXXXXXXX		
0xB0C023A0		DMA0_CMICIC224 00000000 XXXXXXXX XXXXXXXX XXXXXXXX		
0xB0C023A4		DMA0_CMICIC225 00000000 XXXXXXXX XXXXXXXX XXXXXXXX		
0xB0C023A8		DMA0_CMICIC226 00000000 XXXXXXXX XXXXXXXX XXXXXXXX		
0xB0C023AC		DMA0_CMICIC227 00000000 XXXXXXXX XXXXXXXX XXXXXXXX		
0xB0C023B0		DMA0_CMICIC228 00000000 XXXXXXXX XXXXXXXX XXXXXXXX		
0xB0C023B4		DMA0_CMICIC229 00000000 XXXXXXXX XXXXXXXX XXXXXXXX		
0xB0C023B8		DMA0_CMICIC230 00000000 XXXXXXXX XXXXXXXX XXXXXXXX		
0xB0C023BC		DMA0_CMICIC231 00000000 XXXXXXXX XXXXXXXX XXXXXXXX		
0xB0C023C0		DMA0_CMICIC232 00000000 XXXXXXXX XXXXXXXX XXXXXXXX		
0xB0C023C4		DMA0_CMICIC233 00000000 XXXXXXXX XXXXXXXX XXXXXXXX		
0xB0C023C8		DMA0_CMICIC234 00000000 XXXXXXXX XXXXXXXX XXXXXXXX		
0xB0C023CC		DMA0_CMICIC235 00000000 XXXXXXXX XXXXXXXX XXXXXXXX		
0xB0C023D0		DMA0_CMICIC236 00000000 XXXXXXXX XXXXXXXX XXXXXXXX		
0xB0C023D4		DMA0_CMICIC237 00000000 XXXXXXXX XXXXXXXX XXXXXXXX		
0xB0C023D8		DMA0_CMICIC238 00000000 XXXXXXXX XXXXXXXX XXXXXXXX		
0xB0C023DC		DMA0_CMICIC239 00000000 XXXXXXXX XXXXXXXX XXXXXXXX		
0xB0C023E0		DMA0_CMICIC240 00000000 XXXXXXXX XXXXXXXX XXXXXXXX		

Table 39. Memory Layout of PERI5_AHB Registers with Default Values (Continued)

Offset	+3	+2	+1	+0
0xB0C023E4		DMA0_CMICIC241 00000000 XXXXXXXX XXXXXXXX XXXXXXXX		
0xB0C023E8		DMA0_CMICIC242 00000000 XXXXXXXX XXXXXXXX XXXXXXXX		
0xB0C023EC		DMA0_CMICIC243 00000000 XXXXXXXX XXXXXXXX XXXXXXXX		
0xB0C023F0		DMA0_CMICIC244 00000000 XXXXXXXX XXXXXXXX XXXXXXXX		
0xB0C023F4		DMA0_CMICIC245 00000000 XXXXXXXX XXXXXXXX XXXXXXXX		
0xB0C023F8		DMA0_CMICIC246 00000000 XXXXXXXX XXXXXXXX XXXXXXXX		
0xB0C023FC		DMA0_CMICIC247 00000000 XXXXXXXX XXXXXXXX XXXXXXXX		
0xB0C02400		DMA0_CMICIC248 00000000 XXXXXXXX XXXXXXXX XXXXXXXX		
0xB0C02404		DMA0_CMICIC249 00000000 XXXXXXXX XXXXXXXX XXXXXXXX		
0xB0C02408		DMA0_CMICIC250 00000000 XXXXXXXX XXXXXXXX XXXXXXXX		
0xB0C0240C		DMA0_CMICIC251 00000000 XXXXXXXX XXXXXXXX XXXXXXXX		
0xB0C02410		DMA0_CMICIC252 00000000 XXXXXXXX XXXXXXXX XXXXXXXX		
0xB0C02414		DMA0_CMICIC253 00000000 XXXXXXXX XXXXXXXX XXXXXXXX		
0xB0C02418		DMA0_CMICIC254 00000000 XXXXXXXX XXXXXXXX XXXXXXXX		
0xB0C0241C		DMA0_CMICIC255 00000000 XXXXXXXX XXXXXXXX XXXXXXXX		
0xB0C02420		DMA0_CMICIC256 00000000 XXXXXXXX XXXXXXXX XXXXXXXX		
0xB0C02424		DMA0_CMICIC257 00000000 XXXXXXXX XXXXXXXX XXXXXXXX		
0xB0C02428		DMA0_CMICIC258 00000000 XXXXXXXX XXXXXXXX XXXXXXXX		
0xB0C0242C		DMA0_CMICIC259 00000000 XXXXXXXX XXXXXXXX XXXXXXXX		
0xB0C02430		DMA0_CMICIC260 00000000 XXXXXXXX XXXXXXXX XXXXXXXX		
0xB0C02434		DMA0_CMICIC261 00000000 XXXXXXXX XXXXXXXX XXXXXXXX		
0xB0C02438		DMA0_CMICIC262 00000000 XXXXXXXX XXXXXXXX XXXXXXXX		
0xB0C0243C		DMA0_CMICIC263 00000000 XXXXXXXX XXXXXXXX XXXXXXXX		
0xB0C02440		DMA0_CMICIC264 00000000 XXXXXXXX XXXXXXXX XXXXXXXX		
0xB0C02444		DMA0_CMICIC265 00000000 XXXXXXXX XXXXXXXX XXXXXXXX		
0xB0C02448		DMA0_CMICIC266 00000000 XXXXXXXX XXXXXXXX XXXXXXXX		

Table 39. Memory Layout of PERI5_AHB Registers with Default Values (Continued)

Offset	+3	+2	+1	+0
0xB0C0244C		DMA0_CMICIC267 00000000 XXXXXXXX XXXXXXXX XXXXXXXX		
0xB0C02450		DMA0_CMICIC268 00000000 XXXXXXXX XXXXXXXX XXXXXXXX		
0xB0C02454		DMA0_CMICIC269 00000000 XXXXXXXX XXXXXXXX XXXXXXXX		
0xB0C02458		DMA0_CMICIC270 00000000 XXXXXXXX XXXXXXXX XXXXXXXX		
0xB0C0245C		DMA0_CMICIC271 00000000 XXXXXXXX XXXXXXXX XXXXXXXX		
0xB0C02460		DMA0_CMICIC272 00000000 XXXXXXXX XXXXXXXX XXXXXXXX		
0xB0C02464		DMA0_CMICIC273 00000000 XXXXXXXX XXXXXXXX XXXXXXXX		
0xB0C02468		DMA0_CMICIC274 00000000 XXXXXXXX XXXXXXXX XXXXXXXX		
0xB0C0246C		DMA0_CMICIC275 00000000 XXXXXXXX XXXXXXXX XXXXXXXX		
0xB0C02470		DMA0_CMICIC276 00000000 XXXXXXXX XXXXXXXX XXXXXXXX		
0xB0C02474		DMA0_CMICIC277 00000000 XXXXXXXX XXXXXXXX XXXXXXXX		
0xB0C02478		DMA0_CMICIC278 00000000 XXXXXXXX XXXXXXXX XXXXXXXX		
0xB0C0247C		DMA0_CMICIC279 00000000 XXXXXXXX XXXXXXXX XXXXXXXX		
0xB0C02480		DMA0_CMICIC280 00000000 XXXXXXXX XXXXXXXX XXXXXXXX		
0xB0C02484		DMA0_CMICIC281 00000000 XXXXXXXX XXXXXXXX XXXXXXXX		
0xB0C02488		DMA0_CMICIC282 00000000 XXXXXXXX XXXXXXXX XXXXXXXX		
0xB0C0248C		DMA0_CMICIC283 00000000 XXXXXXXX XXXXXXXX XXXXXXXX		
0xB0C02490		DMA0_CMICIC284 00000000 XXXXXXXX XXXXXXXX XXXXXXXX		
0xB0C02494		DMA0_CMICIC285 00000000 XXXXXXXX XXXXXXXX XXXXXXXX		
0xB0C02498		DMA0_CMICIC286 00000000 XXXXXXXX XXXXXXXX XXXXXXXX		
0xB0C0249C		DMA0_CMICIC287 00000000 XXXXXXXX XXXXXXXX XXXXXXXX		
0xB0C024A0		DMA0_CMICIC288 00000000 XXXXXXXX XXXXXXXX XXXXXXXX		
0xB0C024A4		DMA0_CMICIC289 00000000 XXXXXXXX XXXXXXXX XXXXXXXX		
0xB0C024A8		DMA0_CMICIC290 00000000 XXXXXXXX XXXXXXXX XXXXXXXX		
0xB0C024AC		DMA0_CMICIC291 00000000 XXXXXXXX XXXXXXXX XXXXXXXX		
0xB0C024B0		DMA0_CMICIC292 00000000 XXXXXXXX XXXXXXXX XXXXXXXX		

Table 39. Memory Layout of PERI5_AHB Registers with Default Values (Continued)

Offset	+3	+2	+1	+0
0xB0C024B4		DMA0_CMICIC293 00000000 XXXXXXXX XXXXXXXX XXXXXXXX		
0xB0C024B8		DMA0_CMICIC294 00000000 XXXXXXXX XXXXXXXX XXXXXXXX		
0xB0C024BC		DMA0_CMICIC295 00000000 XXXXXXXX XXXXXXXX XXXXXXXX		
0xB0C024C0		DMA0_CMICIC296 00000000 XXXXXXXX XXXXXXXX XXXXXXXX		
0xB0C024C4		DMA0_CMICIC297 00000000 XXXXXXXX XXXXXXXX XXXXXXXX		
0xB0C024C8		DMA0_CMICIC298 00000000 XXXXXXXX XXXXXXXX XXXXXXXX		
0xB0C024CC		DMA0_CMICIC299 00000000 XXXXXXXX XXXXXXXX XXXXXXXX		
0xB0C024D0		DMA0_CMICIC300 00000000 XXXXXXXX XXXXXXXX XXXXXXXX		
0xB0C024D4		DMA0_CMICIC301 00000000 XXXXXXXX XXXXXXXX XXXXXXXX		
0xB0C024D8		DMA0_CMICIC302 00000000 XXXXXXXX XXXXXXXX XXXXXXXX		
0xB0C024DC		DMA0_CMICIC303 00000000 XXXXXXXX XXXXXXXX XXXXXXXX		
0xB0C024E0		DMA0_CMICIC304 00000000 XXXXXXXX XXXXXXXX XXXXXXXX		
0xB0C024E4		DMA0_CMICIC305 00000000 XXXXXXXX XXXXXXXX XXXXXXXX		
0xB0C024E8		DMA0_CMICIC306 00000000 XXXXXXXX XXXXXXXX XXXXXXXX		
0xB0C024EC		DMA0_CMICIC307 00000000 XXXXXXXX XXXXXXXX XXXXXXXX		
0xB0C024F0		DMA0_CMICIC308 00000000 XXXXXXXX XXXXXXXX XXXXXXXX		
0xB0C024F4		DMA0_CMICIC309 00000000 XXXXXXXX XXXXXXXX XXXXXXXX		
0xB0C024F8		DMA0_CMICIC310 00000000 XXXXXXXX XXXXXXXX XXXXXXXX		
0xB0C024FC		DMA0_CMICIC311 00000000 XXXXXXXX XXXXXXXX XXXXXXXX		
0xB0C02500		DMA0_CMICIC312 00000000 XXXXXXXX XXXXXXXX XXXXXXXX		
0xB0C02504		DMA0_CMICIC313 00000000 XXXXXXXX XXXXXXXX XXXXXXXX		
0xB0C02508		DMA0_CMICIC314 00000000 XXXXXXXX XXXXXXXX XXXXXXXX		
0xB0C0250C		DMA0_CMICIC315 00000000 XXXXXXXX XXXXXXXX XXXXXXXX		
0xB0C02510		DMA0_CMICIC316 00000000 XXXXXXXX XXXXXXXX XXXXXXXX		
0xB0C02514		DMA0_CMICIC317 00000000 XXXXXXXX XXXXXXXX XXXXXXXX		
0xB0C02518		DMA0_CMICIC318 00000000 XXXXXXXX XXXXXXXX XXXXXXXX		

Table 39. Memory Layout of PERI5_AHB Registers with Default Values (Continued)

Offset	+3	+2	+1	+0
0xB0C0251C		DMA0_CMICIC319 00000000 XXXXXXXX XXXXXXXX XXXXXXXX		
0xB0C02520		DMA0_CMICIC320 00000000 XXXXXXXX XXXXXXXX XXXXXXXX		
0xB0C02524		DMA0_CMICIC321 00000000 XXXXXXXX XXXXXXXX XXXXXXXX		
0xB0C02528		DMA0_CMICIC322 00000000 XXXXXXXX XXXXXXXX XXXXXXXX		
0xB0C0252C		DMA0_CMICIC323 00000000 XXXXXXXX XXXXXXXX XXXXXXXX		
0xB0C02530		DMA0_CMICIC324 00000000 XXXXXXXX XXXXXXXX XXXXXXXX		
0xB0C02534		DMA0_CMICIC325 00000000 XXXXXXXX XXXXXXXX XXXXXXXX		
0xB0C02538		DMA0_CMICIC326 00000000 XXXXXXXX XXXXXXXX XXXXXXXX		
0xB0C0253C		DMA0_CMICIC327 00000000 XXXXXXXX XXXXXXXX XXXXXXXX		
0xB0C02540		DMA0_CMICIC328 00000000 XXXXXXXX XXXXXXXX XXXXXXXX		
0xB0C02544		DMA0_CMICIC329 00000000 XXXXXXXX XXXXXXXX XXXXXXXX		
0xB0C02548		DMA0_CMICIC330 00000000 XXXXXXXX XXXXXXXX XXXXXXXX		
0xB0C0254C		DMA0_CMICIC331 00000000 XXXXXXXX XXXXXXXX XXXXXXXX		
0xB0C02550		DMA0_CMICIC332 00000000 XXXXXXXX XXXXXXXX XXXXXXXX		
0xB0C02554		DMA0_CMICIC333 00000000 XXXXXXXX XXXXXXXX XXXXXXXX		
0xB0C02558		DMA0_CMICIC334 00000000 XXXXXXXX XXXXXXXX XXXXXXXX		
0xB0C0255C		DMA0_CMICIC335 00000000 XXXXXXXX XXXXXXXX XXXXXXXX		
0xB0C02560		DMA0_CMICIC336 00000000 XXXXXXXX XXXXXXXX XXXXXXXX		
0xB0C02564		DMA0_CMICIC337 00000000 XXXXXXXX XXXXXXXX XXXXXXXX		
0xB0C02568		DMA0_CMICIC338 00000000 XXXXXXXX XXXXXXXX XXXXXXXX		
0xB0C0256C		DMA0_CMICIC339 00000000 XXXXXXXX XXXXXXXX XXXXXXXX		
0xB0C02570		DMA0_CMICIC340 00000000 XXXXXXXX XXXXXXXX XXXXXXXX		
0xB0C02574		DMA0_CMICIC341 00000000 XXXXXXXX XXXXXXXX XXXXXXXX		
0xB0C02578		DMA0_CMICIC342 00000000 XXXXXXXX XXXXXXXX XXXXXXXX		
0xB0C0257C		DMA0_CMICIC343 00000000 XXXXXXXX XXXXXXXX XXXXXXXX		
0xB0C02580		DMA0_CMICIC344 00000000 XXXXXXXX XXXXXXXX XXXXXXXX		

Table 39. Memory Layout of PERI5_AHB Registers with Default Values (Continued)

Offset	+3	+2	+1	+0
0xB0C02584		DMA0_CMICIC345 00000000 XXXXXXXX XXXXXXXX XXXXXXXX		
0xB0C02588		DMA0_CMICIC346 00000000 XXXXXXXX XXXXXXXX XXXXXXXX		
0xB0C0258C		DMA0_CMICIC347 00000000 XXXXXXXX XXXXXXXX XXXXXXXX		
0xB0C02590		DMA0_CMICIC348 00000000 XXXXXXXX XXXXXXXX XXXXXXXX		
0xB0C02594		DMA0_CMICIC349 00000000 XXXXXXXX XXXXXXXX XXXXXXXX		
0xB0C02598		DMA0_CMICIC350 00000000 XXXXXXXX XXXXXXXX XXXXXXXX		
0xB0C0259C		DMA0_CMICIC351 00000000 XXXXXXXX XXXXXXXX XXXXXXXX		
0xB0C025A0		DMA0_CMICIC352 00000000 XXXXXXXX XXXXXXXX XXXXXXXX		
0xB0C025A4		DMA0_CMICIC353 00000000 XXXXXXXX XXXXXXXX XXXXXXXX		
0xB0C025A8		DMA0_CMICIC354 00000000 XXXXXXXX XXXXXXXX XXXXXXXX		
0xB0C025AC		DMA0_CMICIC355 00000000 XXXXXXXX XXXXXXXX XXXXXXXX		
0xB0C025B0		DMA0_CMICIC356 00000000 XXXXXXXX XXXXXXXX XXXXXXXX		
0xB0C025B4		DMA0_CMICIC357 00000000 XXXXXXXX XXXXXXXX XXXXXXXX		
0xB0C025B8		DMA0_CMICIC358 00000000 XXXXXXXX XXXXXXXX XXXXXXXX		
0xB0C025BC		DMA0_CMICIC359 00000000 XXXXXXXX XXXXXXXX XXXXXXXX		
0xB0C025C0		DMA0_CMICIC360 00000000 XXXXXXXX XXXXXXXX XXXXXXXX		
0xB0C025C4		DMA0_CMICIC361 00000000 XXXXXXXX XXXXXXXX XXXXXXXX		
0xB0C025C8		DMA0_CMICIC362 00000000 XXXXXXXX XXXXXXXX XXXXXXXX		
0xB0C025CC		DMA0_CMICIC363 00000000 XXXXXXXX XXXXXXXX XXXXXXXX		
0xB0C025D0		DMA0_CMICIC364 00000000 XXXXXXXX XXXXXXXX XXXXXXXX		
0xB0C025D4		DMA0_CMICIC365 00000000 XXXXXXXX XXXXXXXX XXXXXXXX		
0xB0C025D8		DMA0_CMICIC366 00000000 XXXXXXXX XXXXXXXX XXXXXXXX		
0xB0C025DC		DMA0_CMICIC367 00000000 XXXXXXXX XXXXXXXX XXXXXXXX		
0xB0C025E0		DMA0_CMICIC368 00000000 XXXXXXXX XXXXXXXX XXXXXXXX		
0xB0C025E4		DMA0_CMICIC369 00000000 XXXXXXXX XXXXXXXX XXXXXXXX		
0xB0C025E8		DMA0_CMICIC370 00000000 XXXXXXXX XXXXXXXX XXXXXXXX		

Table 39. Memory Layout of PERI5_AHB Registers with Default Values (Continued)

Offset	+3	+2	+1	+0
0xB0C025EC		DMA0_CMICIC371 00000000 XXXXXXXX XXXXXXXX XXXXXXXX		
0xB0C025F0		DMA0_CMICIC372 00000000 XXXXXXXX XXXXXXXX XXXXXXXX		
0xB0C025F4		DMA0_CMICIC373 00000000 XXXXXXXX XXXXXXXX XXXXXXXX		
0xB0C025F8		DMA0_CMICIC374 00000000 XXXXXXXX XXXXXXXX XXXXXXXX		
0xB0C025FC		DMA0_CMICIC375 00000000 XXXXXXXX XXXXXXXX XXXXXXXX		
0xB0C02600		DMA0_CMICIC376 00000000 XXXXXXXX XXXXXXXX XXXXXXXX		
0xB0C02604		DMA0_CMICIC377 00000000 XXXXXXXX XXXXXXXX XXXXXXXX		
0xB0C02608		DMA0_CMICIC378 00000000 XXXXXXXX XXXXXXXX XXXXXXXX		
0xB0C0260C		DMA0_CMICIC379 00000000 XXXXXXXX XXXXXXXX XXXXXXXX		
0xB0C02610		DMA0_CMICIC380 00000000 XXXXXXXX XXXXXXXX XXXXXXXX		
0xB0C02614		DMA0_CMICIC381 00000000 XXXXXXXX XXXXXXXX XXXXXXXX		
0xB0C02618		DMA0_CMICIC382 00000000 XXXXXXXX XXXXXXXX XXXXXXXX		
0xB0C0261C		DMA0_CMICIC383 00000000 XXXXXXXX XXXXXXXX XXXXXXXX		
0xB0C02620		DMA0_CMICIC384 00000000 XXXXXXXX XXXXXXXX XXXXXXXX		
0xB0C02624		DMA0_CMICIC385 00000000 XXXXXXXX XXXXXXXX XXXXXXXX		
0xB0C02628		DMA0_CMICIC386 00000000 XXXXXXXX XXXXXXXX XXXXXXXX		
0xB0C0262C		DMA0_CMICIC387 00000000 XXXXXXXX XXXXXXXX XXXXXXXX		
0xB0C02630		DMA0_CMICIC388 00000000 XXXXXXXX XXXXXXXX XXXXXXXX		
0xB0C02634		DMA0_CMICIC389 00000000 XXXXXXXX XXXXXXXX XXXXXXXX		
0xB0C02638		DMA0_CMICIC390 00000000 XXXXXXXX XXXXXXXX XXXXXXXX		
0xB0C0263C		DMA0_CMICIC391 00000000 XXXXXXXX XXXXXXXX XXXXXXXX		
0xB0C02640		DMA0_CMICIC392 00000000 XXXXXXXX XXXXXXXX XXXXXXXX		
0xB0C02644		DMA0_CMICIC393 00000000 XXXXXXXX XXXXXXXX XXXXXXXX		
0xB0C02648		DMA0_CMICIC394 00000000 XXXXXXXX XXXXXXXX XXXXXXXX		
0xB0C0264C		DMA0_CMICIC395 00000000 XXXXXXXX XXXXXXXX XXXXXXXX		
0xB0C02650		DMA0_CMICIC396 00000000 XXXXXXXX XXXXXXXX XXXXXXXX		

Table 39. Memory Layout of PERI5_AHB Registers with Default Values (Continued)

Offset	+3	+2	+1	+0
0xB0C02654		DMA0_CMICIC397 00000000 XXXXXXXX XXXXXXXX XXXXXXXX		
0xB0C02658		DMA0_CMICIC398 00000000 XXXXXXXX XXXXXXXX XXXXXXXX		
0xB0C0265C		DMA0_CMICIC399 00000000 XXXXXXXX XXXXXXXX XXXXXXXX		
0xB0C02660		DMA0_CMICIC400 00000000 XXXXXXXX XXXXXXXX XXXXXXXX		
0xB0C02664		DMA0_CMICIC401 00000000 XXXXXXXX XXXXXXXX XXXXXXXX		
0xB0C02668		DMA0_CMICIC402 00000000 XXXXXXXX XXXXXXXX XXXXXXXX		
0xB0C0266C		DMA0_CMICIC403 00000000 XXXXXXXX XXXXXXXX XXXXXXXX		
0xB0C02670		DMA0_CMICIC404 00000000 XXXXXXXX XXXXXXXX XXXXXXXX		
0xB0C02674		DMA0_CMICIC405 00000000 XXXXXXXX XXXXXXXX XXXXXXXX		
0xB0C02678		DMA0_CMICIC406 00000000 XXXXXXXX XXXXXXXX XXXXXXXX		
0xB0C0267C		DMA0_CMICIC407 00000000 XXXXXXXX XXXXXXXX XXXXXXXX		
0xB0C02680		DMA0_CMICIC408 00000000 XXXXXXXX XXXXXXXX XXXXXXXX		
0xB0C02684		DMA0_CMICIC409 00000000 XXXXXXXX XXXXXXXX XXXXXXXX		
0xB0C02688		DMA0_CMICIC410 00000000 XXXXXXXX XXXXXXXX XXXXXXXX		
0xB0C0268C		DMA0_CMICIC411 00000000 XXXXXXXX XXXXXXXX XXXXXXXX		
0xB0C02690		DMA0_CMICIC412 00000000 XXXXXXXX XXXXXXXX XXXXXXXX		
0xB0C02694		DMA0_CMICIC413 00000000 XXXXXXXX XXXXXXXX XXXXXXXX		
0xB0C02698		DMA0_CMICIC414 00000000 XXXXXXXX XXXXXXXX XXXXXXXX		
0xB0C0269C		DMA0_CMICIC415 00000000 XXXXXXXX XXXXXXXX XXXXXXXX		
0xB0C026A0		DMA0_CMICIC416 00000000 XXXXXXXX XXXXXXXX XXXXXXXX		
0xB0C026A4		DMA0_CMICIC417 00000000 XXXXXXXX XXXXXXXX XXXXXXXX		
0xB0C026A8		DMA0_CMICIC418 00000000 XXXXXXXX XXXXXXXX XXXXXXXX		
0xB0C026AC		DMA0_CMICIC419 00000000 XXXXXXXX XXXXXXXX XXXXXXXX		
0xB0C026B0		DMA0_CMICIC420 00000000 XXXXXXXX XXXXXXXX XXXXXXXX		
0xB0C026B4		DMA0_CMICIC421 00000000 XXXXXXXX XXXXXXXX XXXXXXXX		
0xB0C026B8		DMA0_CMICIC422 00000000 XXXXXXXX XXXXXXXX XXXXXXXX		

Table 39. Memory Layout of PERI5_AHB Registers with Default Values (Continued)

Offset	+3	+2	+1	+0
0xB0C026BC		DMA0_CMICIC423 00000000 XXXXXXXX XXXXXXXX XXXXXXXX		
0xB0C026C0		DMA0_CMICIC424 00000000 XXXXXXXX XXXXXXXX XXXXXXXX		
0xB0C026C4		DMA0_CMICIC425 00000000 XXXXXXXX XXXXXXXX XXXXXXXX		
0xB0C026C8		DMA0_CMICIC426 00000000 XXXXXXXX XXXXXXXX XXXXXXXX		
0xB0C026CC		DMA0_CMICIC427 00000000 XXXXXXXX XXXXXXXX XXXXXXXX		
0xB0C026D0		DMA0_CMICIC428 00000000 XXXXXXXX XXXXXXXX XXXXXXXX		
0xB0C026D4		DMA0_CMICIC429 00000000 XXXXXXXX XXXXXXXX XXXXXXXX		
0xB0C026D8		DMA0_CMICIC430 00000000 XXXXXXXX XXXXXXXX XXXXXXXX		
0xB0C026DC		DMA0_CMICIC431 00000000 XXXXXXXX XXXXXXXX XXXXXXXX		
0xB0C026E0		DMA0_CMICIC432 00000000 XXXXXXXX XXXXXXXX XXXXXXXX		
0xB0C026E4		DMA0_CMICIC433 00000000 XXXXXXXX XXXXXXXX XXXXXXXX		
0xB0C026E8		DMA0_CMICIC434 00000000 XXXXXXXX XXXXXXXX XXXXXXXX		
0xB0C026EC		DMA0_CMICIC435 00000000 XXXXXXXX XXXXXXXX XXXXXXXX		
0xB0C026F0		DMA0_CMICIC436 00000000 XXXXXXXX XXXXXXXX XXXXXXXX		
0xB0C026F4		DMA0_CMICIC437 00000000 XXXXXXXX XXXXXXXX XXXXXXXX		
0xB0C026F8		DMA0_CMICIC438 00000000 XXXXXXXX XXXXXXXX XXXXXXXX		
0xB0C026FC		DMA0_CMICIC439 00000000 XXXXXXXX XXXXXXXX XXXXXXXX		
0xB0C02700		DMA0_CMICIC440 00000000 XXXXXXXX XXXXXXXX XXXXXXXX		
0xB0C02704		DMA0_CMICIC441 00000000 XXXXXXXX XXXXXXXX XXXXXXXX		
0xB0C02708		DMA0_CMICIC442 00000000 XXXXXXXX XXXXXXXX XXXXXXXX		
0xB0C0270C		DMA0_CMICIC443 00000000 XXXXXXXX XXXXXXXX XXXXXXXX		
0xB0C02710		DMA0_CMICIC444 00000000 XXXXXXXX XXXXXXXX XXXXXXXX		
0xB0C02714		DMA0_CMICIC445 00000000 XXXXXXXX XXXXXXXX XXXXXXXX		
0xB0C02718		DMA0_CMICIC446 00000000 XXXXXXXX XXXXXXXX XXXXXXXX		
0xB0C0271C		DMA0_CMICIC447 00000000 XXXXXXXX XXXXXXXX XXXXXXXX		
0xB0C02720		DMA0_CMICIC448 00000000 XXXXXXXX XXXXXXXX XXXXXXXX		

Table 39. Memory Layout of PERI5_AHB Registers with Default Values (Continued)

Offset	+3	+2	+1	+0
0xB0C02724		DMA0_CMICIC449 00000000 XXXXXXXX XXXXXXXX XXXXXXXX		
0xB0C02728		DMA0_CMICIC450 00000000 XXXXXXXX XXXXXXXX XXXXXXXX		
0xB0C0272C		DMA0_CMICIC451 00000000 XXXXXXXX XXXXXXXX XXXXXXXX		
0xB0C02730		DMA0_CMICIC452 00000000 XXXXXXXX XXXXXXXX XXXXXXXX		
0xB0C02734		DMA0_CMICIC453 00000000 XXXXXXXX XXXXXXXX XXXXXXXX		
0xB0C02738		DMA0_CMICIC454 00000000 XXXXXXXX XXXXXXXX XXXXXXXX		
0xB0C0273C		DMA0_CMICIC455 00000000 XXXXXXXX XXXXXXXX XXXXXXXX		
0xB0C02740		DMA0_CMICIC456 00000000 XXXXXXXX XXXXXXXX XXXXXXXX		
0xB0C02744		DMA0_CMICIC457 00000000 XXXXXXXX XXXXXXXX XXXXXXXX		
0xB0C02748		DMA0_CMICIC458 00000000 XXXXXXXX XXXXXXXX XXXXXXXX		
0xB0C0274C		DMA0_CMICIC459 00000000 XXXXXXXX XXXXXXXX XXXXXXXX		
0xB0C02750		DMA0_CMICIC460 00000000 XXXXXXXX XXXXXXXX XXXXXXXX		
0xB0C02754		DMA0_CMICIC461 00000000 XXXXXXXX XXXXXXXX XXXXXXXX		
0xB0C02758		DMA0_CMICIC462 00000000 XXXXXXXX XXXXXXXX XXXXXXXX		
0xB0C0275C		DMA0_CMICIC463 00000000 XXXXXXXX XXXXXXXX XXXXXXXX		
0xB0C02760		DMA0_CMICIC464 00000000 XXXXXXXX XXXXXXXX XXXXXXXX		
0xB0C02764		DMA0_CMICIC465 00000000 XXXXXXXX XXXXXXXX XXXXXXXX		
0xB0C02768		DMA0_CMICIC466 00000000 XXXXXXXX XXXXXXXX XXXXXXXX		
0xB0C0276C		DMA0_CMICIC467 00000000 XXXXXXXX XXXXXXXX XXXXXXXX		
0xB0C02770		DMA0_CMICIC468 00000000 XXXXXXXX XXXXXXXX XXXXXXXX		
0xB0C02774		DMA0_CMICIC469 00000000 XXXXXXXX XXXXXXXX XXXXXXXX		
0xB0C02778		DMA0_CMICIC470 00000000 XXXXXXXX XXXXXXXX XXXXXXXX		
0xB0C0277C		DMA0_CMICIC471 00000000 XXXXXXXX XXXXXXXX XXXXXXXX		
0xB0C02780		DMA0_CMICIC472 00000000 XXXXXXXX XXXXXXXX XXXXXXXX		
0xB0C02784		DMA0_CMICIC473 00000000 XXXXXXXX XXXXXXXX XXXXXXXX		
0xB0C02788		DMA0_CMICIC474 00000000 XXXXXXXX XXXXXXXX XXXXXXXX		

Table 39. Memory Layout of PERI5_AHB Registers with Default Values (Continued)

Offset	+3	+2	+1	+0
0xB0C0278C		DMA0_CMICIC475 00000000 XXXXXXXX XXXXXXXX XXXXXXXX		
0xB0C02790		DMA0_CMICIC476 00000000 XXXXXXXX XXXXXXXX XXXXXXXX		
0xB0C02794		DMA0_CMICIC477 00000000 XXXXXXXX XXXXXXXX XXXXXXXX		
0xB0C02798		DMA0_CMICIC478 00000000 XXXXXXXX XXXXXXXX XXXXXXXX		
0xB0C0279C		DMA0_CMICIC479 00000000 XXXXXXXX XXXXXXXX XXXXXXXX		
0xB0C027A0		DMA0_CMICIC480 00000000 XXXXXXXX XXXXXXXX XXXXXXXX		
0xB0C027A4		DMA0_CMICIC481 00000000 XXXXXXXX XXXXXXXX XXXXXXXX		
0xB0C027A8		DMA0_CMICIC482 00000000 XXXXXXXX XXXXXXXX XXXXXXXX		
0xB0C027AC		DMA0_CMICIC483 00000000 XXXXXXXX XXXXXXXX XXXXXXXX		
0xB0C027B0		DMA0_CMICIC484 00000000 XXXXXXXX XXXXXXXX XXXXXXXX		
0xB0C027B4		DMA0_CMICIC485 00000000 XXXXXXXX XXXXXXXX XXXXXXXX		
0xB0C027B8		DMA0_CMICIC486 00000000 XXXXXXXX XXXXXXXX XXXXXXXX		
0xB0C027BC		DMA0_CMICIC487 00000000 XXXXXXXX XXXXXXXX XXXXXXXX		
0xB0C027C0		DMA0_CMICIC488 00000000 XXXXXXXX XXXXXXXX XXXXXXXX		
0xB0C027C4		DMA0_CMICIC489 00000000 XXXXXXXX XXXXXXXX XXXXXXXX		
0xB0C027C8		DMA0_CMICIC490 00000000 XXXXXXXX XXXXXXXX XXXXXXXX		
0xB0C027CC		DMA0_CMICIC491 00000000 XXXXXXXX XXXXXXXX XXXXXXXX		
0xB0C027D0		DMA0_CMICIC492 00000000 XXXXXXXX XXXXXXXX XXXXXXXX		
0xB0C027D4		DMA0_CMICIC493 00000000 XXXXXXXX XXXXXXXX XXXXXXXX		
0xB0C027D8		DMA0_CMICIC494 00000000 XXXXXXXX XXXXXXXX XXXXXXXX		
0xB0C027DC		DMA0_CMICIC495 00000000 XXXXXXXX XXXXXXXX XXXXXXXX		
0xB0C027E0		DMA0_CMICIC496 00000000 XXXXXXXX XXXXXXXX XXXXXXXX		
0xB0C027E4		DMA0_CMICIC497 00000000 XXXXXXXX XXXXXXXX XXXXXXXX		
0xB0C027E8		DMA0_CMICIC498 00000000 XXXXXXXX XXXXXXXX XXXXXXXX		
0xB0C027EC		DMA0_CMICIC499 00000000 XXXXXXXX XXXXXXXX XXXXXXXX		
0xB0C027F0		DMA0_CMICIC500 00000000 XXXXXXXX XXXXXXXX XXXXXXXX		

Table 39. Memory Layout of PERI5_AHB Registers with Default Values (Continued)

Offset	+3	+2	+1	+0
0xB0C027F4		DMA0_CMCHIC501 00000000 XXXXXXXX XXXXXXXX XXXXXXXX		
0xB0C027F8		DMA0_CMCHIC502 00000000 XXXXXXXX XXXXXXXX XXXXXXXX		
0xB0C027FC		DMA0_CMCHIC503 00000000 XXXXXXXX XXXXXXXX XXXXXXXX		
0xB0C02800		DMA0_CMCHIC0 XXXXXXXX XXXXXXXX 00000000 00000010		
0xB0C02804		DMA0_CMCHIC1 XXXXXXXX XXXXXXXX 00000000 00000010		
0xB0C02808		DMA0_CMCHIC2 XXXXXXXX XXXXXXXX 00000000 00000010		
0xB0C0280C		DMA0_CMCHIC3 XXXXXXXX XXXXXXXX 00000000 00000010		
0xB0C02810		DMA0_CMCHIC4 XXXXXXXX XXXXXXXX 00000000 00000010		
0xB0C02814		DMA0_CMCHIC5 XXXXXXXX XXXXXXXX 00000000 00000010		
0xB0C02818		DMA0_CMCHIC6 XXXXXXXX XXXXXXXX 00000000 00000010		
0xB0C0281C		DMA0_CMCHIC7 XXXXXXXX XXXXXXXX 00000000 00000010		
0xB0C02820		DMA0_CMCHIC8 XXXXXXXX XXXXXXXX 00000000 00000010		
0xB0C02824		DMA0_CMCHIC9 XXXXXXXX XXXXXXXX 00000000 00000010		
0xB0C02828		DMA0_CMCHIC10 XXXXXXXX XXXXXXXX 00000000 00000010		
0xB0C0282C		DMA0_CMCHIC11 XXXXXXXX XXXXXXXX 00000000 00000010		
0xB0C02830		DMA0_CMCHIC12 XXXXXXXX XXXXXXXX 00000000 00000010		
0xB0C02834		DMA0_CMCHIC13 XXXXXXXX XXXXXXXX 00000000 00000010		
0xB0C02838		DMA0_CMCHIC14 XXXXXXXX XXXXXXXX 00000000 00000010		
0xB0C0283C		DMA0_CMCHIC15 XXXXXXXX XXXXXXXX 00000000 00000010		
0xB0C02840		DMA0_CMCHIC16 XXXXXXXX XXXXXXXX 00000000 00000010		
0xB0C02844		DMA0_CMCHIC17 XXXXXXXX XXXXXXXX 00000000 00000010		
0xB0C02848		DMA0_CMCHIC18 XXXXXXXX XXXXXXXX 00000000 00000010		
0xB0C0284C		DMA0_CMCHIC19 XXXXXXXX XXXXXXXX 00000000 00000010		
0xB0C02850		DMA0_CMCHIC20 XXXXXXXX XXXXXXXX 00000000 00000010		
0xB0C02854		DMA0_CMCHIC21 XXXXXXXX XXXXXXXX 00000000 00000010		
0xB0C02858		DMA0_CMCHIC22 XXXXXXXX XXXXXXXX 00000000 00000010		

Table 39. Memory Layout of PERI5_AHB Registers with Default Values (Continued)

Offset	+3	+2	+1	+0
0xB0C0285C		DMA0_CMCHIC23 XXXXXXXX XXXXXXXX 00000000 00000010		
0xB0C02860		DMA0_CMCHIC24 XXXXXXXX XXXXXXXX 00000000 00000010		
0xB0C02864		DMA0_CMCHIC25 XXXXXXXX XXXXXXXX 00000000 00000010		
0xB0C02868		DMA0_CMCHIC26 XXXXXXXX XXXXXXXX 00000000 00000010		
0xB0C0286C		DMA0_CMCHIC27 XXXXXXXX XXXXXXXX 00000000 00000010		
0xB0C02870		DMA0_CMCHIC28 XXXXXXXX XXXXXXXX 00000000 00000010		
0xB0C02874		DMA0_CMCHIC29 XXXXXXXX XXXXXXXX 00000000 00000010		
0xB0C02878		DMA0_CMCHIC30 XXXXXXXX XXXXXXXX 00000000 00000010		
0xB0C0287C		DMA0_CMCHIC31 XXXXXXXX XXXXXXXX 00000000 00000010		
0xB0C02880		DMA0_CMCHIC32 XXXXXXXX XXXXXXXX 00000000 00000010		
0xB0C02884		DMA0_CMCHIC33 XXXXXXXX XXXXXXXX 00000000 00000010		
0xB0C02888		DMA0_CMCHIC34 XXXXXXXX XXXXXXXX 00000000 00000010		
0xB0C0288C		DMA0_CMCHIC35 XXXXXXXX XXXXXXXX 00000000 00000010		
0xB0C02890		DMA0_CMCHIC36 XXXXXXXX XXXXXXXX 00000000 00000010		
0xB0C02894		DMA0_CMCHIC37 XXXXXXXX XXXXXXXX 00000000 00000010		
0xB0C02898		DMA0_CMCHIC38 XXXXXXXX XXXXXXXX 00000000 00000010		
0xB0C0289C		DMA0_CMCHIC39 XXXXXXXX XXXXXXXX 00000000 00000010		
0xB0C028A0		DMA0_CMCHIC40 XXXXXXXX XXXXXXXX 00000000 00000010		
0xB0C028A4		DMA0_CMCHIC41 XXXXXXXX XXXXXXXX 00000000 00000010		
0xB0C028A8		DMA0_CMCHIC42 XXXXXXXX XXXXXXXX 00000000 00000010		
0xB0C028AC		DMA0_CMCHIC43 XXXXXXXX XXXXXXXX 00000000 00000010		
0xB0C028B0		DMA0_CMCHIC44 XXXXXXXX XXXXXXXX 00000000 00000010		
0xB0C028B4		DMA0_CMCHIC45 XXXXXXXX XXXXXXXX 00000000 00000010		
0xB0C028B8		DMA0_CMCHIC46 XXXXXXXX XXXXXXXX 00000000 00000010		
0xB0C028BC		DMA0_CMCHIC47 XXXXXXXX XXXXXXXX 00000000 00000010		
0xB0C028C0		DMA0_CMCHIC48 XXXXXXXX XXXXXXXX 00000000 00000010		

Table 39. Memory Layout of PERI5_AHB Registers with Default Values (Continued)

Offset	+3	+2	+1	+0
0xB0C028C4		DMA0_CMCHIC49 XXXXXXXX XXXXXXXX 00000000 00000010		
0xB0C028C8		DMA0_CMCHIC50 XXXXXXXX XXXXXXXX 00000000 00000010		
0xB0C028CC		DMA0_CMCHIC51 XXXXXXXX XXXXXXXX 00000000 00000010		
0xB0C028D0		DMA0_CMCHIC52 XXXXXXXX XXXXXXXX 00000000 00000010		
0xB0C028D4		DMA0_CMCHIC53 XXXXXXXX XXXXXXXX 00000000 00000010		
0xB0C028D8		DMA0_CMCHIC54 XXXXXXXX XXXXXXXX 00000000 00000010		
0xB0C028DC		DMA0_CMCHIC55 XXXXXXXX XXXXXXXX 00000000 00000010		
0xB0C028E0		DMA0_CMCHIC56 XXXXXXXX XXXXXXXX 00000000 00000010		
0xB0C028E4		DMA0_CMCHIC57 XXXXXXXX XXXXXXXX 00000000 00000010		
0xB0C028E8		DMA0_CMCHIC58 XXXXXXXX XXXXXXXX 00000000 00000010		
0xB0C028EC		DMA0_CMCHIC59 XXXXXXXX XXXXXXXX 00000000 00000010		
0xB0C028F0		DMA0_CMCHIC60 XXXXXXXX XXXXXXXX 00000000 00000010		
0xB0C028F4		DMA0_CMCHIC61 XXXXXXXX XXXXXXXX 00000000 00000010		
0xB0C028F8		DMA0_CMCHIC62 XXXXXXXX XXXXXXXX 00000000 00000010		
0xB0C028FC		DMA0_CMCHIC63 XXXXXXXX XXXXXXXX 00000000 00000010		
0xB0C02900- B0C07FFC		reserved XXXXXXXX XXXXXXXX XXXXXXXX XXXXXXXX		
0xB0C08000		MPUXDMA0_CTRL0 00000000 00000000 00000001 00000000		
0xB0C08004		MPUXDMA0_NMIEN XXXXXXXX XXXXXXXX XXXXXXXX 00000001		
0xB0C08008		MPUXDMA0_WERRC XXXXXXXX XXXXXXXX 0000XXXX XXXXXXX0		
0xB0C0800C		MPUXDMA0_WERRA XXXXXXXX XXXXXXXX XXXXXXXX XXXXXXXX		
0xB0C08010		MPUXDMA0_RERRC XXXXXXXX XXXXXXXX 0000XXXX XXXXXXX0		
0xB0C08014		MPUXDMA0_RERRA XXXXXXXX XXXXXXXX XXXXXXXX XXXXXXXX		
0xB0C08018		MPUXDMA0_CTRL1 XXXXXXXX XXXXXXXX 00000000 00000000		
0xB0C0801C		MPUXDMA0_SADDR1 00000000 00000000 00000000 00000000		
0xB0C08020		MPUXDMA0_EADDR1 00000000 00000000 00000000 01111111		
0xB0C08024		MPUXDMA0_CTRL2 XXXXXXXX XXXXXXXX 00000000 00000000		

Table 39. Memory Layout of PERI5_AHB Registers with Default Values (Continued)

Offset	+3	+2	+1	+0
0xB0C08028		MPUXDMA0_SADDR2 00000000 00000000 00000000 00000000		
0xB0C0802C		MPUXDMA0_EADDR2 00000000 00000000 00000000 01111111		
0xB0C08030		MPUXDMA0_CTRL3 XXXXXXXX XXXXXXXX 00000000 00000000		
0xB0C08034		MPUXDMA0_SADDR3 00000000 00000000 00000000 00000000		
0xB0C08038		MPUXDMA0_EADDR3 00000000 00000000 00000000 01111111		
0xB0C0803C		MPUXDMA0_CTRL4 XXXXXXXX XXXXXXXX 00000000 00000000		
0xB0C08040		MPUXDMA0_SADDR4 00000000 00000000 00000000 00000000		
0xB0C08044		MPUXDMA0_EADDR4 00000000 00000000 00000000 01111111		
0xB0C08048		MPUXDMA0_CTRL5 XXXXXXXX XXXXXXXX 00000000 00000000		
0xB0C0804C		MPUXDMA0_SADDR5 00000000 00000000 00000000 00000000		
0xB0C08050		MPUXDMA0_EADDR5 00000000 00000000 00000000 01111111		
0xB0C08054		MPUXDMA0_CTRL6 XXXXXXXX XXXXXXXX 00000000 00000000		
0xB0C08058		MPUXDMA0_SADDR6 00000000 00000000 00000000 00000000		
0xB0C0805C		MPUXDMA0_EADDR6 00000000 00000000 00000000 01111111		
0xB0C08060		MPUXDMA0_CTRL7 XXXXXXXX XXXXXXXX 00000000 00000000		
0xB0C08064		MPUXDMA0_SADDR7 00000000 00000000 00000000 00000000		
0xB0C08068		MPUXDMA0_EADDR7 00000000 00000000 00000000 01111111		
0xB0C0806C		MPUXDMA0_CTRL8 XXXXXXXX XXXXXXXX 00000000 00000000		
0xB0C08070		MPUXDMA0_SADDR8 00000000 00000000 00000000 00000000		
0xB0C08074		MPUXDMA0_EADDR8 00000000 00000000 00000000 01111111		
0xB0C08078		MPUXDMA0_UNLOCK 00000000 00000000 00000000 00000000		
0xB0C0807C		MPUXDMA0_MID 00000000 00000000 00000000 00000000		
0xB0C08080- B0CFFC00		reserved XXXXXXXX XXXXXXXX XXXXXXXX 0000000X		
0xB0CFFC04		BSU5_BTST 00000000 00000000 00000000 00000000		
0xB0CFFC08- B0CFFFC		reserved XXXXXXXX XXXXXXXX XXXXXXXX XXXXXXXX		

Table 40. Memory Layout for SYSTEM_RAM_CONFIG Registers with Default Values

Offset	+7	+6	+5	+4	+3	+2	+1	+0
0xB0D00000	SRCFG_CFG1 00000000 00000000 00000000 00000000				SRCFG_CFG0 00000011 00000011 00000001 00000000			
0xB0D00008	SRCFG_KEY 00000000 00000000 00000000 00000000				SRCFG_CFG2 00000000 00000000 00000000 00000000			
0xB0D00010	SRCFG_INTE 00000000 00000000 00000000 00000000				SRCFG_ERRFLG 00000000 00000000 00000000 00000000			
0xB0D00018	read0 00000000 00000000 00000000 00000000				SRCFG_ECCE 00000000 00000000 00000000 00000001			
0xB0D00020	SRCFG_MID 00000000 00000000 00000000 00000000				SRCFG_ERRADR 00000000 00000000 00000000 00000000			
0xB0D00028- B0D00FF8	reserved XXXXXXXX XXXXXXXX XXXXXXXX XXXXXXXX XXXXXXXX XXXXXXXX XXXXXXXX XXXXXXXX							

Table 41. Memory Layout of EXCFG Registers with Default Values

Offset	+7	+6	+5	+4	+3	+2	+1	+0
0xFFFEF000- FFFEF50	reserved XXXXXXXX XXXXXXXX XXXXXXXX XXXXXXXX XXXXXXXX XXXXXXXX XXXXXXXX XXXXXXXX							
0xFFFEFF58	read0 00000000 00000000 00000000 00000000				EXCFG_UNLOCK 00000000 00000000 00000000 00000000			
0xFFFEFF60	read0 00000000 00000000 00000000 00000000				EXCFG_CNFG 00000000 00000000 00000000 00000001			
0xFFFEFF68- FFFEF78	reserved XXXXXXXX XXXXXXXX XXXXXXXX XXXXXXXX XXXXXXXX XXXXXXXX XXXXXXXX XXXXXXXX							
0xFFFEFF80	EXCFG_UNDEFINACT 11111111 11111111 00000000 00100100				read0 00000000 00000000 00000000 00000000			
0xFFFEFF88	EXCFG_PABORTINACT 11111111 11111111 00000000 00101100				EXCFG_SVCINACT 11111111 11111111 00000000 00101000			
0xFFFEFF90	read0 00000000 00000000 00000000 00000000				EXCFG_DABORTINACT 11111111 11111111 00000000 00110000			
0xFFFEFF98	read0 00000000 00000000 00000000 00000000				EXCFG_IRQINACT 11111111 11111111 00000000 00111000			
0xFFFEFFA0- FFFEFFB8	reserved XXXXXXXX XXXXXXXX XXXXXXXX XXXXXXXX XXXXXXXX XXXXXXXX XXXXXXXX XXXXXXXX							
0xFFFEFFC0	EXCFG_UNDEFACT 11111111 11111111 00000000 00100100				read0 00000000 00000000 00000000 00000000			
0xFFFEFFC8	EXCFG_PABORTACT 11111111 11111111 00000000 00101100				EXCFG_SVCACT 11111111 11111111 00000000 00101000			
0xFFFEFFD0	read0 00000000 00000000 00000000 00000000				EXCFG_DABORTACT 11111111 11111111 00000000 00110000			
0xFFFEFFD8	read0 00000000 00000000 00000000 00000000				EXCFG_IRQACT 11111111 11111111 00000000 00111000			
0xFFFEFFE0- FFFEFF8	reserved XXXXXXXX XXXXXXXX XXXXXXXX XXXXXXXX XXXXXXXX XXXXXXXX XXXXXXXX XXXXXXXX							

Notes

4. SYSC_SPCCFGR:FASTON register bit is reserved and should be always written as '0', since this device does not support "Fast Power domain control" feature.
5. SCCFG_STAT1:EEFCEEN and SCCFG_STAT1:TCFCEEN register bits are read-1 (write has no impact and read always returns '1') in this device.
6. SCCFG_STAT1:FPPEN and SCCFG_STAT1:SCMEN register bits are read-0 (write has no impact and read always returns '0') in this device.

Electrical Characteristics

Absolute Maximum Ratings

Semiconductor devices can be permanently damaged by application of stress (voltage, current, temperature, and so on) in excess of absolute maximum ratings. Do not exceed these ratings.

Table 42. Absolute Maximum Ratings

Parameter	Symbol	Rating		Unit	Remarks
		Min	Max		
Power supply voltage	V_{DP5}	$V_{SS} - 0.3$	$V_{SS} + 6.0$	V	
	V_{DP3}	$V_{SS} - 0.3$	$V_{SS} + 4.0$	V	
	V_{DD}	$V_{SS} - 0.3$	$V_{SS} + 1.8$	V	
	AV_{DD5}	$AV_{SS5} - 0.3$	$AV_{SS5} + 6.0$	V	$V_{DP5} = AV_{DD5}^{[7]}$
AD Converter voltage references	AV_{RH5}	$AV_{SS5} - 0.3$	$AV_{SS5} + 6.0$	V	$AV_{DD5} \geq AV_{RH5} \geq AV_{SS5}$
SMC Power supply	DV_{CC}	$DV_{SS} - 0.3$	$DV_{SS} + 6.0$	V	See Note [9] $V_{DP5} = AV_{DD5} = DV_{CC}$ when ZPD functionality is used
Analog input voltage	V_{IA}	$AV_{SS5} - 0.3$	$AV_{DD5} + 0.3$	V	
Input voltage	V_I	$V_{SS} - 0.3$	$V_{DP5} + 0.3$	V	$V_I \leq DV_{CC}, V_{DP5} + 0.3V^{[8]}$
		$V_{SS} - 0.3$	$V_{DP3} + 0.3$	V	
		$DV_{SS} - 0.3$	$DV_{CC} + 0.3$	V	
Output voltage	V_O	$V_{SS} - 0.3$	$V_{DP5} + 0.3$	V	$V_O \leq DV_{CC}, V_{DP5} + 0.3V^{[8]}$
		$V_{SS} - 0.3$	$V_{DP3} + 0.3$	V	
		$DV_{SS} - 0.3$	$DV_{CC} + 0.3$	V	
Maximum Clamp Current	I_{CLAMP}	-4	+4	mA	Applicable to general purpose I/O pins ^[9]
		-30	+30	mA	Applicable to SMC I/O pins ^[12]
Total Maximum Clamp Current	$\Sigma I_{CLAMP} $	-	20	mA	Applicable to general purpose I/O pins ^[9]
	$\Sigma I_{CLAMPpos}$	-	+360	mA	Applicable to SMC I/O pins ^[12] clamping current occurred by sudden switching-off of inductive load (stepper motor coil).
	$\Sigma I_{CLAMPneg}$	-360	-	mA	Applicable to SMC I/O pins ^[12] clamping current occurred by sudden switching-off of inductive load (stepper motor coil).
	$\Sigma I_{CLAMP} $	-	20	mA	Applicable to SMC I/O pins ^[12] . Total max average over 100 μ s.
"L" level maximum output current	I_{OL1}	-	2	mA	Normal outputs (BIDI50) with driving strength set to 1mA
	I_{OL2}	-	4	mA	Normal outputs (BIDI50) with driving strength set to 2mA
	I_{OL5}	-	10	mA	Normal outputs (BIDI50) with driving strength set to 5mA
	I_{OL12C}	-	6	mA	I2C outputs (I2C) with driving strength set to 3mA
	I_{OLHSIO}	-	24	mA	High Speed outputs (BIDI33) with driving strength set to 12mA
	I_{OLSMC}	-	40	mA	SMC outputs (SMC) with driving strength set to 30mA
	I_{OLTTL2}	-	4	mA	TTL outputs (TTL33, RSDS) with driving strength set to 2mA
	I_{OLTTL5}	-	10	mA	TTL outputs (TTL33, RSDS) with driving strength set to 5mA
	$I_{OLTTL10}$	-	20	mA	TTL outputs (TTL33, RSDS) with driving strength set to 10mA
$I_{OLTTL20}$	-	40	mA	TTL outputs (TTL33, RSDS) with driving strength set to 20mA	
"L" level maximum overall output current	ΣI_{OLVDP5}	-	100	mA	-
	ΣI_{OLVDP3}	-	100	mA	-
	ΣI_{OLDVCC}	-	360	mA	-

Table 42. Absolute Maximum Ratings (Continued)

Parameter	Symbol	Rating		Unit	Remarks
		Min	Max		
"L" level average output current	I _{OLAV1}	-	1	mA	Normal outputs (BIDI50) with driving strength set to 1mA
	I _{OLAV2}	-	2	mA	Normal outputs (BIDI50) with driving strength set to 2mA
	I _{OLAV5}	-	5	mA	Normal outputs (BIDI50) with driving strength set to 5mA
	I _{OLAVI2C}	-	3	mA	I2C outputs (I2C) with driving strength set to 3mA
	I _{OLAVHSIO}	-	12	mA	High Speed outputs (BIDI33) with driving strength set to 12mA
	I _{OLAVSMC}	-	30	mA	SMC outputs (SMC) with driving strength set to 30mA
	I _{OLAVTTL2}	-	2	mA	TTL outputs (TTL33, RSDS) with driving strength set to 2mA
	I _{OLAVTTL5}	-	5	mA	TTL outputs (TTL33, RSDS) with driving strength set to 5mA
	I _{OLAVTTL10}	-	10	mA	TTL outputs (TTL33, RSDS) with driving strength set to 10mA
I _{OLAVTTL20}	-	20	mA	TTL outputs (TTL33, RSDS) with driving strength set to 20mA	
"L" level average overall output current	ΣI _{OLAVDP5}	-	50	mA	-
	ΣI _{OLAVDP3}	-	50	mA	-
	ΣI _{OLADVCC}	-	230	mA	-
"H" level maximum output current	I _{OH1}	-	-2	mA	Normal outputs (BIDI50) with driving strength set to 1mA
	I _{OH2}	-	-4	mA	Normal outputs (BIDI50) with driving strength set to 2mA
	I _{OH5}	-	-10	mA	Normal outputs (BIDI50) with driving strength set to 5mA
	I _{OHI2C}	-	-6	mA	I2C outputs (I2C) with driving strength set to 3mA
	I _{OHHSIO}	-	-24	mA	High Speed outputs (BIDI33) with driving strength set to 12mA
	I _{OHSMC}	-	-40	mA	SMC outputs (SMC) with driving strength set to 30mA
	I _{OHTTL2}	-	-4	mA	TTL outputs (TTL33, RSDS) with driving strength set to 2mA
	I _{OHTTL5}	-	-10	mA	TTL outputs (TTL33, RSDS) with driving strength set to 5mA
	I _{OHTTL10}	-	-20	mA	TTL outputs (TTL33, RSDS) with driving strength set to 10mA
I _{OHTTL20}	-	-40	mA	TTL outputs (TTL33, RSDS) with driving strength set to 20mA	
"H" level maximum overall output current	ΣI _{OHVDP5}	-	-100	mA	-
	ΣI _{OHVDP3}	-	-100	mA	-
	ΣI _{OHVCC}	-	-360	mA	-
"H" level average output current	I _{OHAV1}	-	-1	mA	Normal outputs (BIDI50) with driving strength set to 1mA
	I _{OHAV2}	-	-2	mA	Normal outputs (BIDI50) with driving strength set to 2mA
	I _{OHAV5}	-	-5	mA	Normal outputs (BIDI50) with driving strength set to 5mA
	I _{OHAVI2C}	-	-3	mA	I2C outputs (I2C) with driving strength set to 3mA
	I _{OHAVHSIO}	-	-12	mA	High Speed outputs (BIDI33) with driving strength set to 12mA
	I _{OHAVSMC}	-	-30	mA	SMC outputs (SMC) with driving strength set to 30mA
	I _{OHAVTTL2}	-	-2	mA	TTL outputs (TTL33, RSDS) with driving strength set to 2mA
	I _{OHAVTTL5}	-	-5	mA	TTL outputs (TTL33, RSDS) with driving strength set to 5mA
	I _{OHAVTTL10}	-	-10	mA	TTL outputs (TTL33, RSDS) with driving strength set to 10mA
I _{OHAVTTL20}	-	-20	mA	TTL outputs (TTL33, RSDS) with driving strength set to 20mA	
"H" level average overall output current	ΣI _{OHAVDP5}	-	-50	mA	-
	ΣI _{OHAVDP3}	-	-50	mA	-
	ΣI _{OHADVCC}	-	-230	mA	-

Table 42. Absolute Maximum Ratings (Continued)

Parameter	Symbol	Rating		Unit	Remarks
		Min	Max		
Differential maximum output current	I _{ODHRSDS0}	-	4	mA	RSDS outputs (RSDS) with RSDS BOOST = 0
	I _{ODHRSDS1}	-	8	mA	RSDS outputs (RSDS) with RSDS BOOST = 1
Differential maximum output current overall output current	ΣI _{ODHVDP3}	-	100	mA	-
Differential average output current	I _{ODAVRSDS0}		2	mA	RSDS outputs (RSDS) with RSDS BOOST = 0
	I _{ODAVRSDS1}		4	mA	RSDS outputs (RSDS) with RSDS BOOST = 1
Differential average output current overall output current	ΣI _{ODAVVDP3}		50	mA	-
Power consumption	P _{TOT}	-	2000	mW	-
Operating ambient temperature	T _A	-40	105	°C	-
Storage temperature	T _{STG}	-55	150	°C	-

Notes

7. AV_{DD5} and V_{DP5} must be set to the same voltage. It is required that AV_{DD5} does not exceed V_{DP5} and that the voltage at the analog inputs does not exceed AV_{DD5} neither when the power is switched on.
8. V_I and V_O should not exceed V_{DP5} + 0.3 V. V_I should also not exceed the specified ratings. However if the maximum current to/from a input is limited by some means with external components, the I_{CLAMP} rating supersedes the V_I rating. Input/output voltages of standard ports depend on V_{DP5}.
9. Clamping current limitation:
 - Applicable to all general purpose I/O pins (Pi_{jj})
 - Use within recommended operating conditions.
 - Use at DC voltage (current).
 - The +B signal should always be applied a limiting resistance placed between the +B signal and the microcontroller.
 - The value of the limiting resistance should be set so that when the +B signal is applied the input current to the microcontroller pin does not exceed rated values, either instantaneously or for prolonged periods.
 - Note that when the microcontroller drive current is low, such as in the power saving modes, the +B input potential may pass through the protective diode and increase the potential at the V_{DP5} pin, and this may affect other devices.
 - Note that if a +B signal is input when the microcontroller power supply is off (not fixed at 0 V), the power supply is provided from the pins, so that incomplete operation may result.
 - Note that if the +B input is applied during power-on, the power supply is provided from the pins and the resulting supply voltage may not be sufficient to operate the Power reset (except devices with persistent low voltage reset in internal vector mode).
10. Sample recommended circuits is shown in Figure 3.

Figure 3. ESD Protection Structure for GPIO Pins

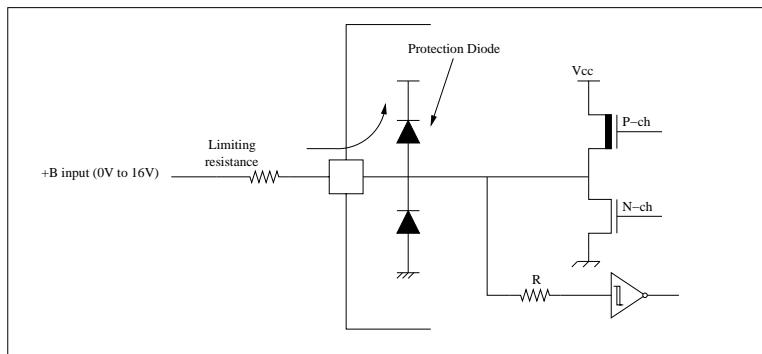

11. DV_{CC}, AV_{DD5} and V_{DP5} must be set to the same voltage during zero point detection (ZPD) on any of the SMC ports. If zero point detection is not required on any of the SMC ports, then DV_{CC} can have any value with-in absolute rating, provided switches are disabled by R1CFG0_ADC0ZPDEN:ZPDEN register. Note, for ZPD, conversion time will be more and accuracy of measurement will be low.
12. Clamping current limitation for SMC pins:
 - Clamping current occurred by sudden switching-off for an inductive load (stepper motor coils).
 - The Clamping structure of high current SMC pins is independent on the drive strength settings.

Figure 4. ESD Protection Structure for SMC Pins

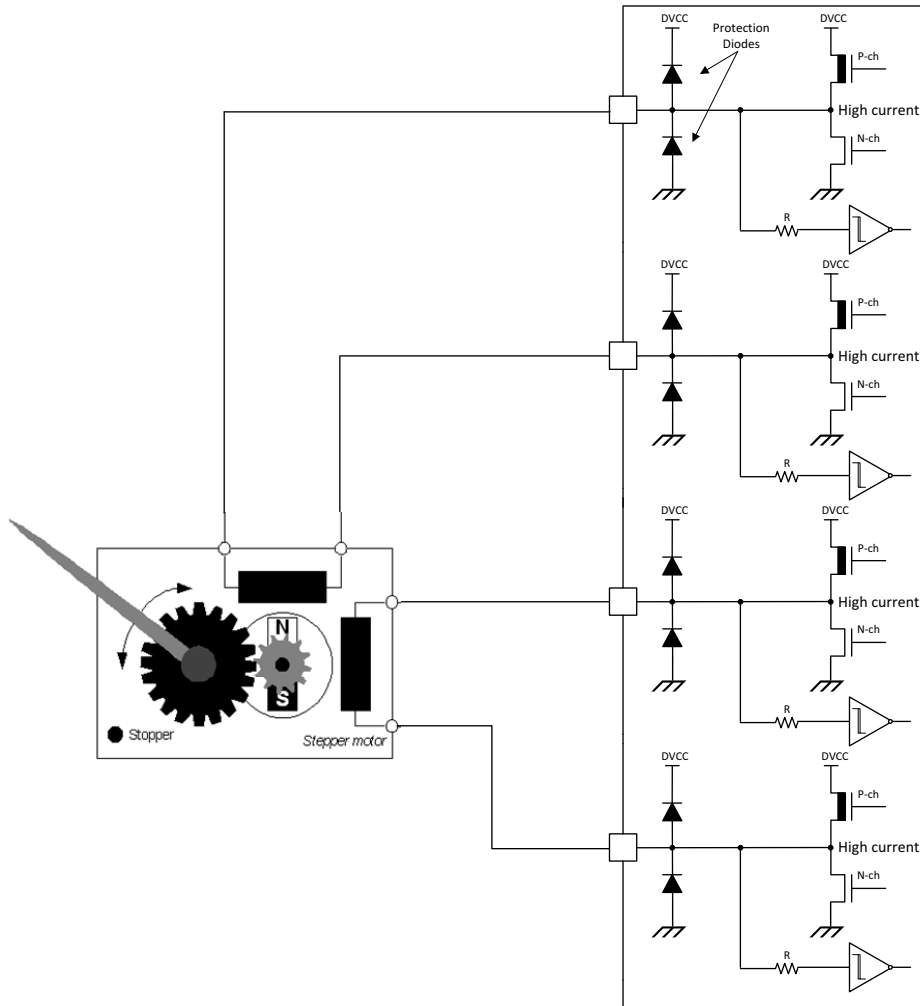

Recommended Operating Conditions
Table 43. Recommended Operating Conditions

Parameter	Symbol	Value			Unit	Remarks
		Min	Typ	Max		
5V power supply voltage	V _{DP5}	3.0	3.3/5.0	5.5	V	
3.3V power supply voltage	V _{DP3}	3.0	3.3	3.6	V	
1.2V power supply voltage	V _{DD}	1.1	1.2	1.3	V	
SMC power supply voltage	DV _{CC}	4.5	5.0	5.5	V	If used as SMC
	DV _{CC}	3.0	3.3/5.0	5.5	V	If used as GPIO
Analog power supply voltage	AV _{DD5}	3.0	3.3/5.0	5.5	V	
AD Converter voltage reference	AV _{RH5}	AV _{DD5} - 0.5	-	AV _{DD5}	V	
Operation ambient temperature	T _{OP}	-40	-	105	°C	

Warning: The recommended operating conditions are required in order to ensure the normal operation of the semiconductor device. All of the devices electrical characteristics are guaranteed when the device is operated within these ranges.

Always use semiconductor devices within their recommended operating condition ranges. Operating outside these ranges may adversely affect reliability and could result in device failure.

No warranty is made with respect to uses, operating conditions, or combinations not represented on the data sheet. Users considering application outside the listed conditions are advised to contact their representatives beforehand.

DC Characteristics

($T_A = -40^\circ\text{C}$ to 105°C , $V_{DD} = 1.1\text{V}$ to 1.3V , $V_{DP3} = 3.0\text{V}$ to 3.6V , $V_{DP5} = AV_{DD5} = 3.0\text{V}$ to 5.5V , $DV_{CC} = 3.0\text{V}$ to 5.5V , $V_{SS} = AV_{SS5} = DV_{SS} = 0\text{V}$)

Table 44. DC Characteristics

Parameter	Symbol	Pin	Condition	Value			Unit	Remarks
				Min	Typ	Max		
Input "H" voltage	V_{IH}	Port inputs Pi_{ij}	BIDI50 / SMC CMOS	$0.8 \times V_{DP5}$	-	V_{DP5}	V	$4.5\text{V} \leq V_{DP5} \leq 5.5\text{V}$
				$0.8 \times V_{DP5}$	-	V_{DP5}	V	$3.0\text{V} \leq V_{DP5} \leq 3.6\text{V}$
			BIDI50 / SMC Hysteresis	$0.8 \times V_{DP5}$	-	V_{DP5}	V	$4.5\text{V} \leq V_{DP5} \leq 5.5\text{V}$
				$0.8 \times V_{DP5}$	-	V_{DP5}	V	$3.0\text{V} \leq V_{DP5} \leq 3.6\text{V}$
			BIDI50 / SMC / I2C AUTOMOTIVE	$0.8 \times V_{DP5}$	-	V_{DP5}	V	$4.5\text{V} \leq V_{DP5} \leq 5.5\text{V}$
				$0.8 \times V_{DP5}$	-	V_{DP5}	V	$3.0\text{V} \leq V_{DP5} \leq 3.6\text{V}$
			BIDI50 / SMC / I2C TTL	2.0	-	V_{DP5}	V	$4.5\text{V} \leq V_{DP5} \leq 5.5\text{V}$
				2.0	-	V_{DP5}	V	$3.0\text{V} \leq V_{DP5} \leq 3.6\text{V}$
			I2C CMOS	$0.7 \times V_{DP5}$	-	V_{DP5}	V	$4.5\text{V} \leq V_{DP5} \leq 5.5\text{V}$
				$0.7 \times V_{DP5}$	-	V_{DP5}	V	$3.0\text{V} \leq V_{DP5} \leq 3.6\text{V}$
			I2C Hysteresis	$0.7 \times V_{DP5}$	-	V_{DP5}	V	$4.5\text{V} \leq V_{DP5} \leq 5.5\text{V}$
				$0.7 \times V_{DP5}$	-	V_{DP5}	V	$3.0\text{V} \leq V_{DP5} \leq 3.6\text{V}$
	V_{IH}	X0	4 MHz Oscillator	$0.8 \times V_{DP5}$	-	V_{DP3}	V	$4.5\text{V} \leq V_{DP5} \leq 5.5\text{V}$
				$0.8 \times V_{DP5}$	-	V_{DP5}	V	$3.0\text{V} \leq V_{DP5} \leq 3.6\text{V}$
	V_{IH}	X0A	32 KHz Oscillator	$0.8 \times V_{DP5}$	-	V_{DP5}	V	$4.5\text{V} \leq V_{DP5} \leq 5.5\text{V}$
				$0.8 \times V_{DP5}$	-	V_{DP5}	V	$3.0\text{V} \leq V_{DP5} \leq 3.6\text{V}$
	V_{IHXDF}	X0	External clock in "Fast Clock Input mode"	$0.7 \times V_{DP5}$	-	V_{DP5}	V	$4.5\text{V} \leq V_{DP5} \leq 5.5\text{V}$
				$0.7 \times V_{DP5}$	-	V_{DP5}	V	$3.0\text{V} \leq V_{DP5} \leq 3.6\text{V}$
	V_{IHXOS}	X0,X1, X0A,X1A	External clock in "oscillation mode"	$0.8 \times V_{DP5}$	-	V_{DP5}	V	$4.5\text{V} \leq V_{DP5} \leq 5.5\text{V}$
				$0.8 \times V_{DP5}$	-	V_{DP5}	V	$3.0\text{V} \leq V_{DP5} \leq 3.6\text{V}$
V_{IHR}	RSTX	MODE/RSTX CMOS Hysteresis	$0.7 \times V_{DP5}$	-	V_{DP5}	V	$4.5\text{V} \leq V_{DP5} \leq 5.5\text{V}$	
			$0.7 \times V_{DP5}$	-	V_{DP5}	V	$3.0\text{V} \leq V_{DP5} \leq 3.6\text{V}$	
V_{IHM}	MODE	MODE/RSTX CMOS Hysteresis	$0.7 \times V_{DP5}$	-	V_{DP5}	V	$4.5\text{V} \leq V_{DP5} \leq 5.5\text{V}$	
			$0.7 \times V_{DP5}$	-	V_{DP5}	V	$3.0\text{V} \leq V_{DP5} \leq 3.6\text{V}$	
V_{IHHSIO}	pi_{ij}	BIDI33 / TTL33 / RSDS Hysteresis	$0.7 \times V_{DP3}$	-	V_{DP3}	V	$3.0\text{V} \leq V_{DP3} \leq 3.6\text{V}$	
		BIDI33 / TTL33 / RSDS TTL	2	-	V_{DP3}	V	$3.0\text{V} \leq V_{DP3} \leq 3.6\text{V}$	

Table 44. DC Characteristics (Continued)

Parameter	Symbol	Pin	Condition	Value			Unit	Remarks
				Min	Typ	Max		
Input "L" voltage	V _{IL}	Port inputs pi_jj	BIDI50 / SMC CMOS	V _{SS}	-	0.2 x V _{DP5}	V	4.5V ≤ V _{DP5} ≤ 5.5V
				V _{SS}	-	0.2 x V _{DP5}	V	3.0V ≤ V _{DP5} ≤ 3.6V
			BIDI50 / SMC Hysteresis	V _{SS}	-	0.2 x V _{DP5}	V	4.5V ≤ V _{DP5} ≤ 5.5V
				V _{SS}	-	0.2 x V _{DP5}	V	3.0V ≤ V _{DP5} ≤ 3.6V
			BIDI50 / SMC / I2C AUTOMOTIVE	V _{SS}	-	0.5 x V _{DP5}	V	4.5V ≤ V _{DP5} ≤ 5.5V
				V _{SS}	-	0.3 x V _{DP5}	V	3.0V ≤ V _{DP5} ≤ 3.6V
			BIDI50 / SMC / I2C TTL	V _{SS}	-	0.8	V	4.5V ≤ V _{DP5} ≤ 5.5V
				V _{SS}	-	0.8	V	3.0V ≤ V _{DP5} ≤ 3.6V
			I2C CMOS	V _{SS}	-	0.3 x V _{DP5}	V	4.5V ≤ V _{DP5} ≤ 5.5V
				V _{SS}	-	0.2 x V _{DP5}	V	3.0V ≤ V _{DP5} ≤ 3.6V
			I2C Hysteresis	V _{SS}	-	0.3 x V _{DP5}	V	4.5V ≤ V _{DP5} ≤ 5.5V
				V _{SS}	-	0.2 x V _{DP5}	V	3.0V ≤ V _{DP5} ≤ 3.6V
	V _{IL}	X0	4 MHz Oscillator	V _{SS}	-	0.2 x V _{DP5}	V	4.5V ≤ V _{DP5} ≤ 5.5V
				V _{SS}	-	0.2 x V _{DP5}	V	3.0V ≤ V _{DP5} ≤ 3.6V
	V _{IL}	X0A	32 KHz Oscillator	V _{SS}	-	0.2 x V _{DP5}	V	4.5V ≤ V _{DP5} ≤ 5.5V
				V _{SS}	-	0.2 x V _{DP5}	V	3.0V ≤ V _{DP5} ≤ 3.6V
	V _{ILX0F}	X0	External clock in "Fast Clock Input mode"	V _{SS}	-	0.3 x V _{DP5}	V	4.5V ≤ V _{DP5} ≤ 5.5V
				V _{SS}	-	0.3 x V _{DP5}	V	3.0V ≤ V _{DP5} ≤ 3.6V
	V _{ILX0S}	X0,X1, X0A,X1A	External clock in "oscillation mode"	V _{SS}	-	0.2 x V _{DP5}	V	4.5V ≤ V _{DP5} ≤ 5.5V
				V _{SS}	-	0.2 x V _{DP5}	V	3.0V ≤ V _{DP5} ≤ 3.6V
	V _{ILR}	RSTX	MODE/RSTX CMOS Hysteresis	V _{SS}	-	0.3 x V _{DP5}	V	4.5V ≤ V _{DP5} ≤ 5.5V
				V _{SS}	-	0.3 x V _{DP5}	V	3.0V ≤ V _{DP5} ≤ 3.6V
	V _{ILM}	MODE	MODE/RSTX CMOS Hysteresis	V _{SS}	-	0.3 x V _{DP5}	V	4.5V ≤ V _{DP5} ≤ 5.5V
				V _{SS}	-	0.3 x V _{DP5}	V	3.0V ≤ V _{DP5} ≤ 3.6V
V _{ILHSIO}	pi_jj	BIDI33 / TTL33 / RSDS Hysteresis	V _{SS}	-	0.2 x V _{DP3}	V	3.0V ≤ V _{DP3} ≤ 3.6V	
		BIDI33 / TTL33 / RSDS TTL	V _{SS}	-	0.8	V	3.0V ≤ V _{DP3} ≤ 3.6V	

Table 44. DC Characteristics (Continued)

Parameter	Symbol	Pin	Condition	Value			Unit	Remarks	
				Min	Typ	Max			
Hysteresis	V_{HYS}	Port inputs pi_jj	BIDI50 / SMC CMOS	-	-	-	V	$4.5V \leq V_{DP5} \leq 5.5V$	
				-	-	-	V	$3.0V \leq V_{DP5} \leq 3.6V$	
			BIDI50 / SMC Hysteresis	$0.05 \times V_{DP5}$	-	-	V	$4.5V \leq V_{DP5} \leq 5.5V$	
				$0.05 \times V_{DP5}$	-	-	V	$3.0V \leq V_{DP5} \leq 3.6V$	
			BIDI50 / SMC / I2C AUTOMOTIVE	0.35	-	-	V	$4.5V \leq V_{DP5} \leq 5.5V$	
				0.35	-	-	V	$3.0V \leq V_{DP5} \leq 3.6V$	
			BIDI50 / SMC / I2C TTL	0.1	-	-	V	$4.5V \leq V_{DP5} \leq 5.5V$	
				0.1	-	-	V	$3.0V \leq V_{DP5} \leq 3.6V$	
			I2C CMOS	-	-	-	V	$4.5V \leq V_{DP5} \leq 5.5V$	
				-	-	-	V	$3.0V \leq V_{DP5} \leq 3.6V$	
			I2C Hysteresis	$0.05 \times V_{DP5}$	-	-	V	$4.5V \leq V_{DP5} \leq 5.5V$	
				$0.05 \times V_{DP5}$	-	-	V	$3.0V \leq V_{DP5} \leq 3.6V$	
			X0	4 MHz Oscillator	$0.05 \times V_{DP5}$	-	-	V	$4.5V \leq V_{DP5} \leq 5.5V$
					$0.05 \times V_{DP5}$	-	-	V	$3.0V \leq V_{DP5} \leq 3.6V$
		X0A	32 KHz Oscillator	$0.05 \times V_{DP5}$	-	-	V	$4.5V \leq V_{DP5} \leq 5.5V$	
				$0.05 \times V_{DP5}$	-	-	V	$3.0V \leq V_{DP5} \leq 3.6V$	
		X0	External clock in "Fast Clock Input mode"	$0.05 \times V_{DP5}$	-	-	V	$4.5V \leq V_{DP5} \leq 5.5V$	
				$0.05 \times V_{DP5}$	-	-	V	$3.0V \leq V_{DP5} \leq 3.6V$	
		X0,X1, X0A,X1A	External clock in "oscillation mode"	$0.05 \times V_{DP5}$	-	-	V	$4.5V \leq V_{DP5} \leq 5.5V$	
				$0.05 \times V_{DP5}$	-	-	V	$3.0V \leq V_{DP5} \leq 3.6V$	
		RSTX	MODE/RSTX CMOS Hysteresis	$0.05 \times V_{DP5}$	-	-	V	$4.5V \leq V_{DP5} \leq 5.5V$	
				$0.05 \times V_{DP5}$	-	-	V	$3.0V \leq V_{DP5} \leq 3.6V$	
MODE	MODE/RSTX CMOS Hysteresis	$0.05 \times V_{DP5}$	-	-	V	$4.5V \leq V_{DP5} \leq 5.5V$			
		$0.05 \times V_{DP5}$	-	-	V	$3.0V \leq V_{DP5} \leq 3.6V$			
pi_jj	BIDI33 / TTL33 / RSDS Hysteresis	$0.05 \times V_{DP3}$	-	-	V	$3.0V \leq V_{DP3} \leq 3.6V$			
		0.1	-	-	V	$3.0V \leq V_{DP3} \leq 3.6V$			

Table 44. DC Characteristics (Continued)

Parameter	Symbol	Pin	Condition	Value			Unit	Remarks
				Min	Typ	Max		
Output "H" voltage	V _{OH1}	BIDI50 / SMC / I ² C outputs (VDP5)	4.5V ≤ V _{DP5} ≤ 5.5V I _{OH} = -1mA	V _{DP5} - 0.5	-	-	V	Driving strength set to 1mA
			3.0V ≤ V _{DP5} ≤ 3.6V I _{OH} = -0.8mA					
	V _{OH2}	BIDI50 / SMC / I ² C outputs (VDP5)	4.5V ≤ V _{DP5} ≤ 5.5V I _{OH} = -2mA	V _{DP5} - 0.5	-	-	V	Driving strength set to 2mA
			3.0V ≤ V _{DP5} ≤ 3.6V I _{OH} = -1.5mA					
	V _{OH5}	BIDI50 / SMC / I ² C outputs (VDP5)	4.5V ≤ V _{DP5} ≤ 5.5V I _{OH} = -5mA	V _{DP5} - 0.5	-	-	V	Driving strength set to 5mA
			3.0V ≤ V _{DP5} ≤ 3.6V I _{OH} = -3mA					
	V _{OH3}	I ² C outputs (VDP5)	4.5V ≤ V _{DP5} ≤ 5.5V	-	-	-	V	Pseudo Open Drain (HIZ for logic value 1)
			3.0V ≤ V _{DP5} ≤ 3.6V					
	V _{OHSMC}	SMC outputs (DV _{CC})	4.5V ≤ V _{DP5} ≤ 5.5V I _{OH} = -30mA	DV _{CC} - 0.5	-	DV _{CC}	V	Driving strength set to 30mA
			3.0V ≤ V _{DP5} ≤ 3.6V I _{OH} = -20mA					Driving strength set to 30mA
	V _{OH3X}	32 KHz oscillator outputs (VDP5)	4.5V ≤ V _{DP5} ≤ 5.5V I _{OH} = -20uA	V _{DP5} - 1.3	-	V _{DP5}	V	-
			3.0V ≤ V _{DP5} ≤ 3.6V I _{OH} = -11uA					
	V _{OH4X}	4 MHz oscillator outputs (VDP5)	4.5V ≤ V _{DP5} ≤ 5.5V I _{OH} = -200uA	V _{DP5} - 0.9	-	V _{DP5}	V	-
			3.0V ≤ V _{DP5} ≤ 3.6V I _{OH} = -115uA					
V _{OH12}	BIDI33 outputs (VDP3)	3.0V ≤ V _{DP3} ≤ 3.6V I _{OH} = -11mA	V _{DP3} - 0.5	-	V _{DP3}	V	Driving strength set to 12mA	
V _{OH2}	RSDS / TTL33 outputs (VDP3)	3.0V ≤ V _{DP3} ≤ 3.6V I _{OH} = -2mA	V _{DP3} - 0.5	-	V _{DP3}	V	Driving strength set to 2mA	
V _{OH5}	RSDS / TTL33 outputs (VDP3)	3.0V ≤ V _{DP3} ≤ 3.6V I _{OH} = -5mA	V _{DP3} - 0.5	-	V _{DP3}	V	Driving strength set to 5mA	
V _{OH10}	RSDS / TTL33 outputs (VDP3)	3.0V ≤ V _{DP3} ≤ 3.6V I _{OH} = -10mA	V _{DP3} - 0.6	-	V _{DP3}	V	Driving strength set to 10mA	
Output "H" voltage	V _{OH20}	RSDS / TTL33 outputs (VDP3)	3.0V ≤ V _{DP3} ≤ 3.6V I _{OH} = -20mA	V _{DP3} - 0.5	-	V _{DP3}	V	Driving strength set to 20mA

Table 44. DC Characteristics (Continued)

Parameter	Symbol	Pin	Condition	Value			Unit	Remarks
				Min	Typ	Max		
Output "L" voltage	V _{OL1}	BID150 / SMC / I ² C outputs (VDP5)	4.5V ≤ V _{DP5} ≤ 5.5V I _{OL} = +1mA	V _{SS}	-	0.4	V	Driving strength set to 1mA
			3.0V ≤ V _{DP5} ≤ 3.6V I _{OL} = +0.8mA					
	V _{OL2}	BID150 / SMC / I ² C outputs (VDP5)	4.5V ≤ V _{DP5} ≤ 5.5V I _{OL} = +2mA	V _{SS}	-	0.4	V	Driving strength set to 2mA
			3.0V ≤ V _{DP5} ≤ 3.6V I _{OL} = +1.5mA					
	V _{OL5}	BID150 / SMC / I ² C outputs (VDP5)	4.5V ≤ V _{DP5} ≤ 5.5V I _{OL} = +5mA	V _{SS}	-	0.4	V	Driving strength set to 5mA
			3.0V ≤ V _{DP5} ≤ 3.6V I _{OL} = +3mA					
	V _{OL3}	I ² C outputs (VDP5)	4.5V ≤ V _{DP5} ≤ 5.5V I _{OL} = +3mA	V _{SS}	-	0.4	V	Driving strength set to 3mA
			3.0V ≤ V _{DP5} ≤ 3.6V I _{OL} = +1.7mA					
	V _{OLSMC}	SMC outputs (DV _{CC})	4.5V ≤ V _{DP5} ≤ 5.5V I _{OH} = +30mA	DV _{SS}	-	0.5	V	Driving strength set to 30mA
			3.0V ≤ V _{DP5} ≤ 3.6V I _{OH} = +20mA					Driving strength set to 30mA
	V _{OL3X}	32 KHz oscillator outputs (VDP5)	4.5V ≤ V _{DP5} ≤ 5.5V I _{OH} = +20uA	V _{SS}	-	1.2	V	-
			3.0V ≤ V _{DP5} ≤ 3.6V I _{OH} = +11uA					
	V _{OL4X}	4 MHz oscillator outputs (VDP5)	4.5V ≤ V _{DP5} ≤ 5.5V I _{OH} = +200uA	V _{SS}	-	1.2	V	-
3.0V ≤ V _{DP5} ≤ 3.6V I _{OH} = +115uA								
V _{OL12}	Normal outputs (VDP3)	3.0V ≤ V _{DP3} ≤ 3.6V I _{OL} = +11mA	V _{SS}	-	0.4	V	Driving strength set to 12mA	
V _{OL2}	RSDS outputs (VDP3)	3.0V ≤ V _{DP3} ≤ 3.6V I _{OH} = +2mA	V _{SS}	-	0.4	V	Driving strength set to 2mA	
V _{OL5}	RSDS / TTL33 outputs (VDP3)	3.0V ≤ V _{DP3} ≤ 3.6V I _{OH} = +5mA	V _{SS}	-	0.5	V	Driving strength set to 5mA	
V _{OL10}	RSDS / TTL33 outputs (VDP3)	3.0V ≤ V _{DP3} ≤ 3.6V I _{OH} = +10mA	V _{SS}	-	0.55	V	Driving strength set to 10mA	
Output "L" voltage	V _{OL20}	RSDS / TTL33 outputs (VDP3)	3.0V ≤ V _{DP3} ≤ 3.6V I _{OH} = +20mA	V _{SS}	-	0.5	V	Driving strength set to 20mA
Output differential voltage amplitude	V _{OD}	RSDS outputs (VDP3)	3.0V ≤ V _{DP3} ≤ 3.6V	100	-	600	mV	1) BOOST = 1, RL=50Ω 2) BOOST = 0, RL= 100Ω
Output common voltage	V _{OCM}	RSDS outputs (VDP3)	3.0V ≤ V _{DP3} ≤ 3.6V	0.5	-	1.5	V	-
Input leak current	I _{IL}	pi _{jj} (GPIO)	-	-1	-	+1	μA	T _A = 25°C
			-	-3	-	+3	μA	T _A = 105°C
		pi _{jj} (ANIN)	-	-1	-	+1	μA	T _A = 25°C
			-	-3	-	+3	μA	T _A = 105°C

Table 44. DC Characteristics (Continued)

Parameter	Symbol	Pin	Condition	Value			Unit	Remarks
				Min	Typ	Max		
Total input leakage current	ΣI_{IL}	pi_{jj} (GPIO, ANIN)	$V_{DP5} \geq V_{IN} \geq V_{SS}$ $AV_{DD5} \geq V_{IN} \geq AV_{SS5}$ $\Sigma(1 \text{ to } n) [\max(I_{LH} , I_{LL})]$ I_{LH} : leakage at high level input I_{LL} : leakage at low level input	-	-	15	μA	i = number of IO = 30 GPIO (in VDP5 IO domain)
		pi_{jj} (GPIO)	$V_{DP3} \geq V_{IN} \geq V_{SS}$ $\Sigma(1 \text{ to } n) [\max(I_{LH} , I_{LL})]$ I_{LH} : leakage at high level input I_{LL} : leakage at low level input	-	-	30	μA	i = number of IO = 63 GPIO (in VDP3 IO domain)
		pi_{jj} (GPIO)	$DV_{CC} \geq V_{IN} \geq V_{SS}$ $\Sigma(1 \text{ to } n) [\max(I_{LH} , I_{LL})]$ I_{LH} : leakage at high level input I_{LL} : leakage at low level input	-	-	15	μA	i = number of IO = 24 GPIO (in DVCC IO domain)
Pull-up resistance	R_{UP}	pi_{jj} , (BIDI50/SMC/I2C)	$4.5V \leq V_{DP5} \leq 5.5V$	25	50	100	$k\Omega$	
			$3.0V \leq V_{DP5} \leq 3.6V$	25	50	200	$k\Omega$	
		pi_{jj} , (BIDI33/TTL33/RSDS)	$3.0V \leq V_{DP3} \leq 3.6V$	15	33	80	$k\Omega$	
Pull-down resistance	R_{DN}	pi_{jj} , (BIDI50/SMC/I2C)	$4.5V \leq V_{DP5} \leq 5.5V$	25	50	100	$k\Omega$	
			$3.0V \leq V_{DP5} \leq 3.6V$	25	50	200	$k\Omega$	
		pi_{jj} , (BIDI33/TTL33/RSDS)	$3.0V \leq V_{DP3} \leq 3.6V$	15	33	80	$k\Omega$	
Low voltage detection current	I_{LYDETI}	(VDP5)	-	-	30	80	μA	Operational
			-	-	0.008	5	μA	Standby
Main oscillator current (4 MHz)	I_{MOSCR}	(VDP5)	-	-	160	300	μA	Operational@ 4MHz load = 10pF
	I_{MOSCS}		-	-	-	5	μA	Standby
Sub oscillator current (32 kHz)	I_{SOSCR}	(VDP5)	-	-	10	25	μA	Operational
	I_{SOSCS}		-	-	-	3	μA	Standby
Slow RC oscillator current (100kHz)	I_{RCS}	(VDD)	-	-	2	6	μA	Operational
			-	-	-	0.1	μA	Standby
Fast RC oscillator current (8 MHz)	I_{RFC8}	(VDD)	-	-	7	11	μA	Operational (average with trimming)
		(VDP5)	-	-	305	700	μA	Operational (average with trimming)
		(VDD)	-	-	0.01	3	μA	Standby
		(VDP5)	-	-	0.003	3	μA	Standby
Fast RC oscillator current (12 MHz)	I_{RFC12}	(VDD)	-	-	11	16	μA	Operational (average with trimming)
		(VDP5)	-	-	416	1050	μA	Operational (average with trimming)
		(VDD)	-	-	0.01	3	μA	Standby
		(VDP5)	-	-	0.003	3	μA	Standby
Input capacitance	C_{IN}	-	-	-	5	15	pF	Other than supply pins

Table 44. DC Characteristics (Continued)

Parameter	Symbol	Pin	Condition	Value			Unit	Remarks		
				Min	Typ	Max				
Power supply current in RUN mode	I _{CCRUN}	(VDD)	RUN mode current of PD1+PD2	-	175	mA	25°C	with all clocks at max frequency, Includes leakage of respective PD		
				-	255		105°C			
		(VDD)	RUN mode current of PD4	-	2	mA	25°C			
				-	2.8		105°C			
Power supply current in PSS mode	I _{CCPSS}	(VDD)	Leakage current of PD1	-	0.4	mA	25°C	-		
				-	3.75		105°C			
		(VDD)	Leakage current of PD2	-	7.2	mA	25°C			
				-	96		105°C			
		(VDD)	Leakage current of PD4	-	0.1	mA	25°C			
				-	0.8		105°C			
Power supply current in Timer mode	I _{CCTMAIN}	(VDD)	Main Timer mode with CLKMC = 4MHz	-	0.66	mA	25°C	with PD2, PD4, switched off		
				-	4.1		105°C			
	I _{CCTRCH}	(VDD)	RC Timer mode with CLKRC = 12MHz	-	0.6	mA	25°C			
				-	3.95		105°C			
	I _{CCTRCL}	(VDD)	Main Timer mode with CLKSRC = 100kHz	-	0.57	mA	25°C			
				-	3.92		105°C			
	I _{CCTSUB}	(VDD)	Sub Timer mode with CLKSC = 32kHz	-	0.56	mA	25°C			
				-	3.91		105°C			
TCFLASH Read current (64 MHz)	I _{CCTC-FLASHRD}	(VDD)	Current for one Instruction Flash module	-	32.9	mA	105°C	Only applicable if PD2 is ON		
		(VDP5)		-	21		105°C			
TCFLASH Program/Erase current	I _{CCTC-FLASHPE}	(VDD)		-	1.8	mA	105°C			
		(VDP5)		-	11.3		105°C			
TCFLASH Sleep current	I _{CCTC-FLASHSB}	(VDD)		-	412	μA	105°C			
		(VDP5)		-	11.3		105°C			
Power consumption	P _{OP}	-		-	-	1250	mW		-	-

AC Characteristics
Source Clock Timing

(TA = -40 °C to 105 °C, VDD = 1.1V to 1.3V, VDP3 = 3.0V to 3.6V, VDP5 = AVDD5 = 3.0V to 5.5V, DVCC = 3.0V to 5.5V, VSS = AVSS5 = DVSS = 0V)

Table 45. Source Clock Timing

Parameter	Symbol	Pin	Value			Unit	Remarks
			Min	Typ	Max		
Oscillator Clock Frequency	f_c	X0,X1	3	4	5	MHz	When using a crystal oscillator, PLL off
			-	4	-	MHz	When using an opposite phase external clock, PLL off
			-	4	-	MHz	When using a crystal oscillator or opposite phase external clock, PLL on. PLL input clock divider (PLLDIVL) must be greater than 1 since PLL does not support input clock freq more than 16MHz
Oscillator Clock Frequency	f_{FCI}	X0	0	-	62.5	MHz	When using a single phase external clock in "Fast Clock Input mode", PLL off
			4	-	62.5	MHz	When using a single phase external clock in Fast Clock Input mode, PLL on PLL input clock divider (PLLDIVL) must be greater than 1 since PLL does not support input clock freq more than 16MHz
Oscillator Clock Frequency	f_{CL}	X0A, X1A	32	32.768	100	kHz	When using an oscillation circuit
			0	-	100	kHz	When using a opposite phase external clock
		X0A	0	-	50	kHz	When using a single phase external clock
Slow Clock Frequency	f_{CRS}	-	50	100	150	kHz	When using slow frequency of RC oscillator
Fast RCO Clock Frequency	f_{CRF}	-	6.3	7.9	10.1	MHz	When using fast frequency of RC oscillator (8MHz mode) and SYSC_RCCFGR:TRM[7:0] = 0x7F
			9.3	11.6	14.6	MHz	When using fast frequency of RC oscillator (12MHz mode) and SYSC_RCCFGR:TRM[7:0] = 0x7F
Fast RCO Clock Stability	f_{PRCF}	-	-2	-	+2	%	TA = 0..70 °C
			-6	-	+6	%	TA = -40..105 °C
PLL Clock Frequency	f_{CLKVCO}	-	200	-	400	MHz	Permitted VCO output frequency of PLL (CLKVCO) Please also see limitation for f_{PLLVCO} input frequency
PLL Input Frequency (after DIVL)	f_{PLLVCO}	-	4	-	16	MHz	Input frequency of PLL after PLLDIVL divider. PLL input clock divider (PLLDIVL) must be greater than 1, if the frequency at the Clock input exceeds 16MHz
PLL Phase Jitter	T_{PSKEW}	-	-5	-	±5	ns	For CLKMC (PLL input clock) - 4 MHz, jitter coming from external oscillator, crystal or resonator is not yet recovered
Input Clock Pulse Width	P_{WH}, P_{WL}	X0, X1	8	-	-	ns	Duty ratio is about 30% to 70%
Input Clock Pulse Width	P_{WHL}, P_{WLL}	X0A, X1A	5	-	-	ns	-

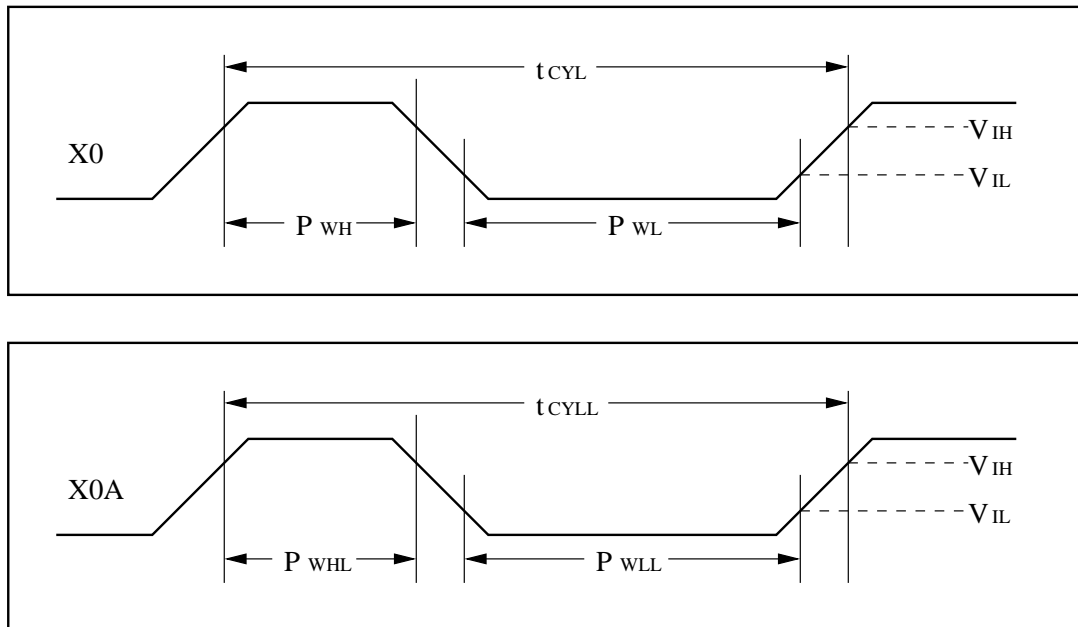
Figure 5. Source Clock Timing

Internal Clock Timing

($T_A = -40\text{ }^\circ\text{C}$ to $105\text{ }^\circ\text{C}$, $V_{DD} = 1.1\text{V}$ to 1.3V , $V_{DP3} = 3.0\text{V}$ to 3.6V , $V_{DP5} = AV_{DD5} = 3.0\text{V}$ to 5.5V , $DV_{CC} = 3.0\text{V}$ to 5.5V , $V_{SS} = AV_{SS5} = DV_{SS} = 0\text{V}$)

Table 46. Internal Clock Timing

Parameter	Symbol	Min	Max	Unit	Remarks
CLK_SYS_PD3	fCLK_SYS_PD3	0	128	MHz	-
CLK_DBG_PD2	fCLK_DBG_PD2	0	128	MHz	-
CLK_DBG_PD3	fCLK_DBG_PD3	0	128	MHz	-
CLK_TRACE_PD2	fCLK_TRACE_PD2	0	128	MHz	-
CLK_TRACE_PD3	fCLK_TRACE_PD3	0	128	MHz	-
CLK_HPM_PD2	fCLK_HPM_PD2	0	128	MHz	-
CLK_HPM_PD3	fCLK_HPM_PD3	0	128	MHz	-
CLK_CFG_PD4	fCLK_CFG_PD4	0	64	MHz	-
CLK_DMA_PD2	fCLK_DMA_PD2	0	128	MHz	-
CLK_MEM_I_PD3	fCLK_MEM_I_PD3	0	128	MHz	-
CLK_MEM_E_PD3	fCLK_MEM_E_PD3	0	128	MHz	-
CLK_CFG_PD1	fCLK_CFG_PD1	0	64	MHz	-
CLK_PERI4_PD2	fCLK_PERI4_PD2 ^[13]	0	128	MHz	-
CLK_GFX_PD5	fCLK_GFX_PD5		128	MHz	-
CLK_PERI0_PD2	fCLK_PERI0_PD2	0	64	MHz	-
CLK_PERI1_PD2	fCLK_PERI1_PD2	0	32	MHz	-
CLK_PERI3_PD2	fCLK_PERI3_PD2	0	64	MHz	-
CLK_SPI_PD5	fCLK_SPI_PD5		128	MHz	-
CLK_PIX_PD5	fCLK_PIX_PD5		400	MHz	-
CLK_SPI_PD3	fCLK_SPI_PD3	0	128	MHz	-

Table 46. Internal Clock Timing (Continued)

Parameter	Symbol	Min	Max	Unit	Remarks
CKOT, CKOTX	fCKOT, fCKOTX	0	128	MHz	Internal clock, set clock divider >4 for output

Note

13. If MediaLB is used, a minimum CLK_PERI4_PD2 value of 50 MHz is required. In addition, the system must be able to handle 6MByte/sec on the bus. This means that depending on the bus traffic, as well as access to system RAM by other masters, higher CLK_PERI4_PD2 values are required.

External Reset Timing

($T_A = -40\text{ }^\circ\text{C}$ to $105\text{ }^\circ\text{C}$, $V_{DD} = 1.1\text{V}$ to 1.3V , $V_{DP3} = 3.0\text{V}$ to 3.6V , $V_{DP5} = AV_{DD5} = 3.0\text{V}$ to 5.5V , $DV_{CC} = 3.0\text{V}$ to 5.5V , $V_{SS} = AV_{SS5} = DV_{SS} = 0\text{V}$)

Table 47. External Reset Timing

Parameter	Symbol	Pin	Value			Unit	Remarks
			Min	Typ	Max		
Reset input time	t_{RSTL}	RSTX	500	-	-	ns	-

Figure 6. External Reset Timing

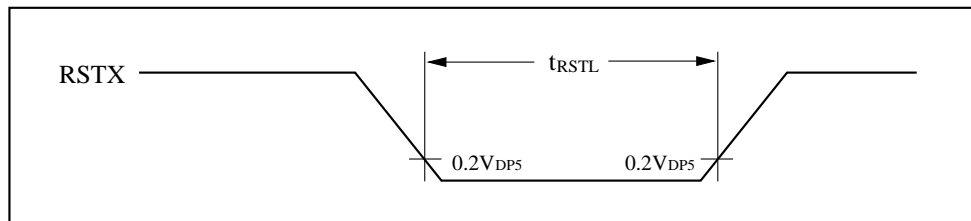

External Input Timing

($T_A = -40\text{ }^\circ\text{C}$ to $105\text{ }^\circ\text{C}$, $V_{DD} = 1.1\text{V}$ to 1.3V , $V_{DP3} = 3.0\text{V}$ to 3.6V , $V_{DP5} = AV_{DD5} = 3.0\text{V}$ to 5.5V , $DV_{CC} = 3.0\text{V}$ to 5.5V , $V_{SS} = AV_{SS5} = DV_{SS} = 0\text{V}$)

Table 48. External Input Timing

Parameter	Symbol	Pin	Condition	Value		Unit	Used Pin Input Function
				Min	Max		
Input pulse width	t_{INH} t_{INL}	EIC0_INTk	-	200	-	ns	External Interrupt
		NMI					NMI
		Pi_jj		$2 * t_{CLK_PER} + t_{NF}^{[14, 15]}$	-	ns	General purpose IO
		RLTn_TIN					Reload Timer
		PPG_ETRGx					PPG Trigger input
		ADCn_EDGI					AD Converter Trigger
		FRTn_FRCK					Free Running Timer external clock
		ICUn_INm					Input Capture
UDCn_AIN, UDCn_BIN, UDCn_ZIN	Up/Down Counter						

Notes

14. t_{CLK_PER} is the period of the corresponding peripheral clock.
 15. t_{NF} is 200ns, if noise filter is enabled and 0ns, if noise filter is bypassed.

Figure 7. External Input Timing

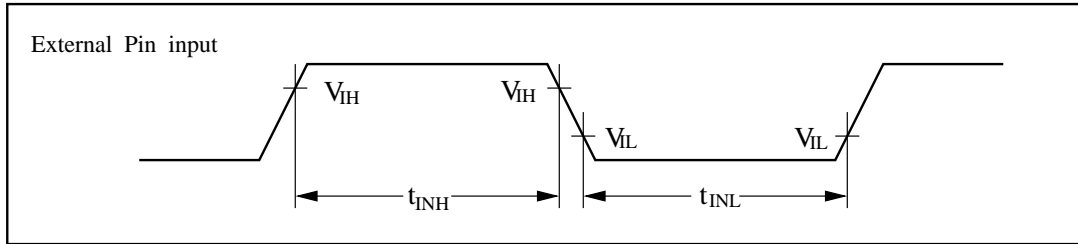

Slew Rate High Current Outputs

($T_A = -40\text{ }^{\circ}\text{C}$ to $105\text{ }^{\circ}\text{C}$, $V_{DD} = 1.1\text{V}$ to 1.3V , $V_{DP3} = 3.0\text{V}$ to 3.6V , $V_{DP5} = AV_{DD5} = 3.0\text{V}$ to 5.5V , $DV_{CC} = 3.0\text{V}$ to 5.5V , $V_{SS} = AV_{SS5} = DV_{SS} = 0\text{V}$)

Table 49. Slew Rate High Current Outputs

Parameter	Symbol	Pin	Condition	Value		Unit	Remarks
				Min	Max		
Output rise/fall time	t_{R30} t_{F30}	I/O circuit type SMC	Output driving strength set to "30mA"	15 at $C_{LOAD} = 0\text{ pF}$	-	ns	-

Figure 8. Slew Rate High Current Output Timing

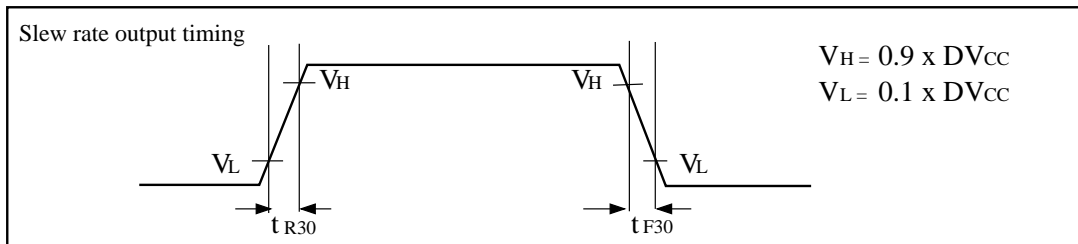

USART Timing

Note The values given below are for an I/O drive strength IO drive = 5mA. If IO drive is 2mA, all the maximum output timing described in the different tables must be increased by 10ns.

($T_A = -40\text{ }^\circ\text{C}$ to $105\text{ }^\circ\text{C}$, $V_{DD} = 1.1\text{V}$ to 1.3V , $V_{DP3} = 3.0\text{V}$ to 3.6V , $V_{DP5} = 3.0\text{V}$ to 5.5V , $DV_{CC} = 3.0\text{V}$ to 5.5V , $V_{SS} = 0\text{V}$, $I_{Odrive} = 5\text{ mA}$, $C_L = 50\text{ pF}$)

Table 50. USART Timing

Parameter	Symbol	Pin	Condition	$V_{DP5} = 4.5\text{V to }5.5\text{V}$		$V_{DP5} = 3.0\text{V to }4.5\text{V}$		Unit
				Min	Max	Min	Max	
Serial clock cycle time	t_{SCYCI}	SCK	Internal Shift Clock Mode	$4 * t_{CLK_PERIO_PD2}$	-	$4 * t_{CLK_PERIO_PD2}$	-	ns
SCK SOT delay time	t_{SLOVI}	SCK, SOT		-20	+20	-30	+30	ns
SOT SCK delay time	t_{OVSHI}	SCK, SOT		$N * t_{CLK_PERIO_PD2} - 20^{[19]}$	-	$N * t_{CLK_PERIO_PD2} - 30^{[19]}$	-	ns
Valid SIN SCK	t_{IVSHI}	SCK, SIN		$t_{CLK_PERIO_PD2} + 45$	-	$t_{CLK_PERIO_PD2} + 55$	-	ns
SCK Valid SIN hold time	t_{SHIXI}	SCK, SIN		0	-	0	-	ns
Serial clock "L" pulse width	t_{SLBHE}	SCK	External Shift Clock Mode	$t_{CLK_PERIO_PD2} + 10$	-	$t_{CLK_PERIO_PD2} + 10$	-	ns
Serial clock "H" pulse width	t_{SHSLE}	SCK		$t_{CLK_PERIO_PD2} + 10$	-	$t_{CLK_PERIO_PD2} + 10$	-	ns
SCK SOT delay time	t_{SLOVE}	SCK, SOT		-	$2 * t_{CLK_PERIO_PD2} + 45$	-	$2 * t_{CLK_PERIO_PD2} + 45$	ns
Valid SIN SCK	t_{IVSHE}	SCK, SIN		$t_{CLK_PERIO_PD2} / 2 + 10$	-	$t_{CLK_PERIO_PD2} / 2 + 10$	-	ns
SCK Valid SIN hold time	t_{SHIXE}	SCK, SIN		$t_{CLK_PERIO_PD2} + 10$	-	$t_{CLK_PERIO_PD2} + 10$	-	ns
SCK fall time	t_{FE}	SCK		-	20	-	20	ns
SCK rise time	t_{RE}	SCK		-	20	-	20	ns

Notes

16. AC characteristic in CLK synchronized mode.
17. CL is the load capacity value of pins when testing.
18. Depending on the used machine clock frequency, the maximum possible baud rate can be limited by some parameters.
 $t_{CLK_PERIO_PD2}$ is the cycle time of the clock (CLK_PERIO_PD2), Unit: ns
19. Parameter N depends on t_{SCYCI} and can be calculated as follows:
 - if $t_{SCYCI} = 2 * k * t_{CLK_PERIO_PD2}$, then $N = k$, where k is an integer > 2
 - if $t_{SCYCI} = (2 * k + 1) * t_{CLK_PERIO_PD2}$, then $N = k + 1$, where k is an integer > 1.

Examples

t_{SCYCI}	N
$4 * t_{CLK_PERIO_PD2}$	2
$5 * t_{CLK_PERIO_PD2}$	3
$6 * t_{CLK_PERIO_PD2}$	
$7 * t_{CLK_PERIO_PD2}$	4
$8 * t_{CLK_PERIO_PD2}$	
....

Figure 9. USART Timing

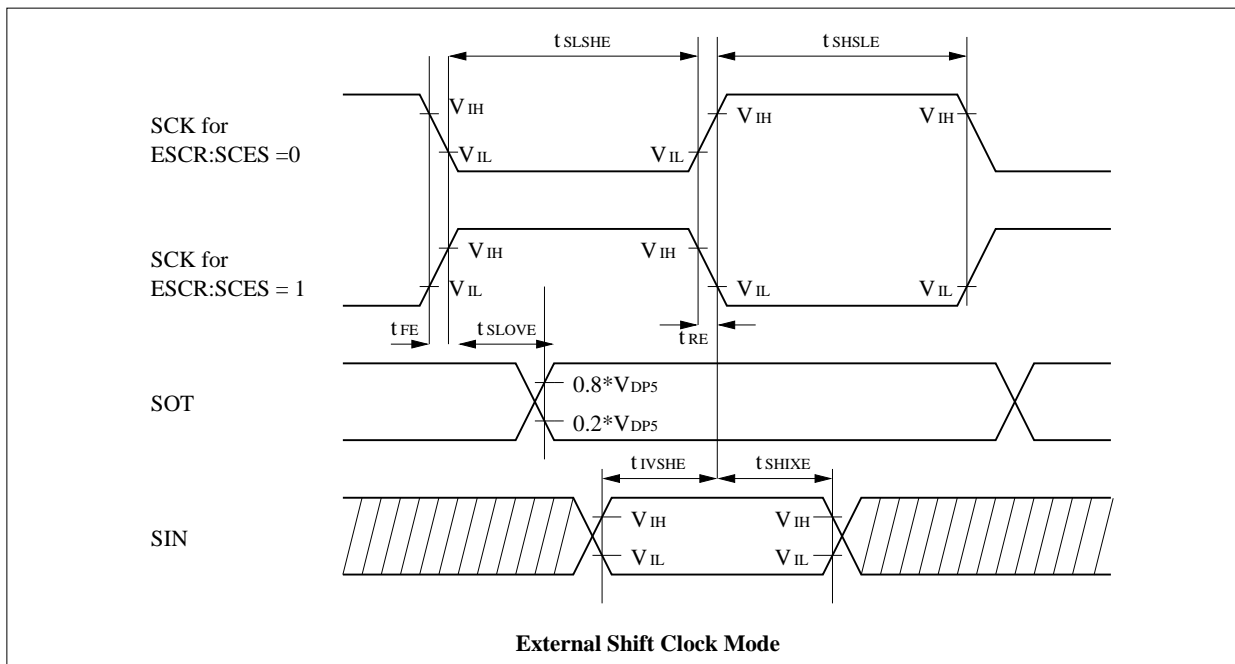
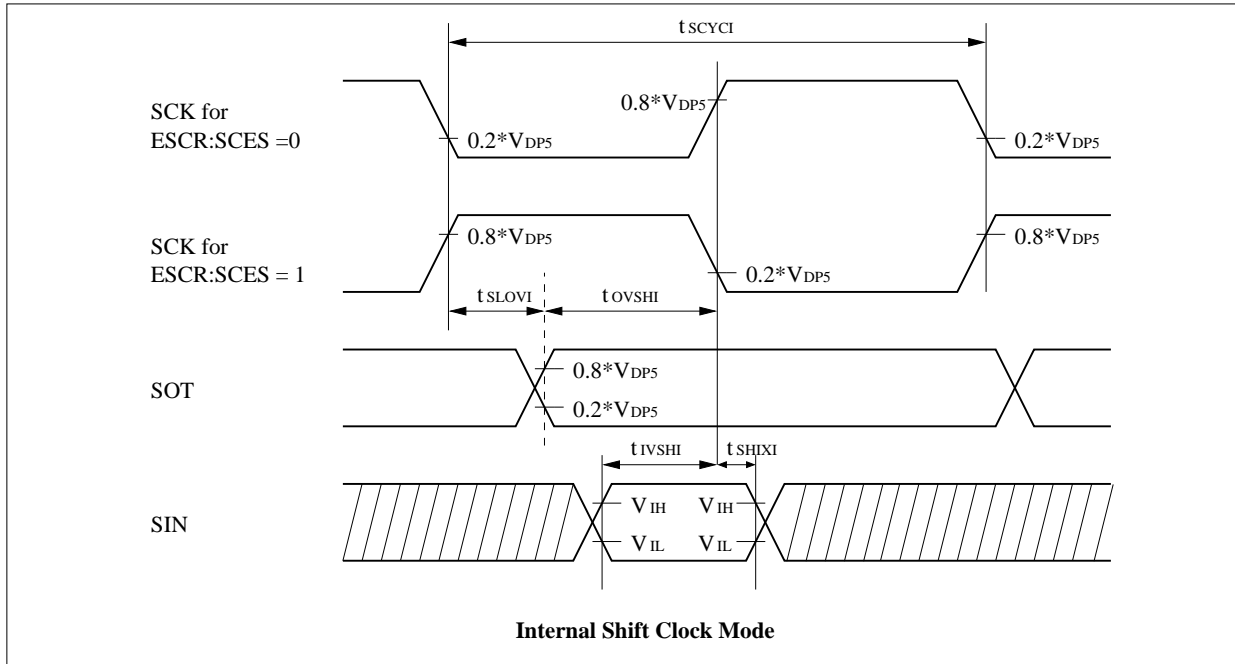

I²C Timing

($T_A = -40\text{ }^{\circ}\text{C}$ to $105\text{ }^{\circ}\text{C}$, $V_{DD} = 1.1\text{V}$ to 1.3V , $V_{DP3} = 3.0\text{V}$ to 3.6V , $V_{DP5} = AV_{DD5} = 4.5\text{V}$ to 5.5V ^[19], $DV_{CC} = 3.0\text{V}$ to 5.5V , $V_{SS} = AV_{SS5} = DV_{SS} = 0\text{V}$)

Table 51. I²C Timing

Parameter	Symbol	Standard-Mode		Fast-Mode		Unit
		Min	Max	Min	Max	
SCL clock frequency	f_{SCL}	0	100	0	400	kHz
Hold time (repeated) START condition SDA \downarrow →SCL \downarrow	t_{HDSTA}	4.0	-	0.6	-	μs
“L” width of the SCL clock	t_{LOW}	4.7	-	1.3	-	μs
“H” width of the SCL clock	t_{HIGH}	4.0	-	0.6	-	μs
Set-up time for a repeated START condition SCL \uparrow →SDA \downarrow	t_{SUSTA}	4.7	-	0.6	-	μs
Data hold time SCL \downarrow →SDA \downarrow ↑	t_{HDDAT}	0	3.45	0	0.9	μs
Data set-up time SDA \rightarrow →SCL \uparrow -	t_{SUDAT}	250	-	100	-	ns
Set-up time for STOP condition SCL \rightarrow ↑→SDA \uparrow	t_{SUSTO}	4	-	0.6	-	μs
Bus free time between a STOP and START condition	t_{BUS}	4.7	-	1.3	-	μs
Output fall time from $0.7 \cdot V_{DP5}$ to $0.3 \cdot V_{DP5}$ with a bus capacitance from 10pF to 400pF	t_{of}	$20 + 0.1 \cdot C_b$ ^[21]	250	$20 + 0.1 \cdot C_b$ ^[21]	250	ns
Capacitive load for each bus line	C_b	-	400	-	400	pF
Pulse width of spikes which will be suppressed by input noise filter	t_{SP}	n/a	n/a	0	$1 \cdot t_{CLK_PERIO_PD2}$ ^[22]	ns

Notes

20. For use at over 100 kHz, set the CLK_PERIO_PD2 to at least 6 MHz.
21. C_b = capacitance of one bus line in pF.
22. $t_{CLK_PERIO_PD2}$ is the cycle time of the peripheral clock CLK_PERIO_PD2
23. I²C spec only guaranteed at $V_{DP5} = 4.5\text{V}$ to 5.5V .

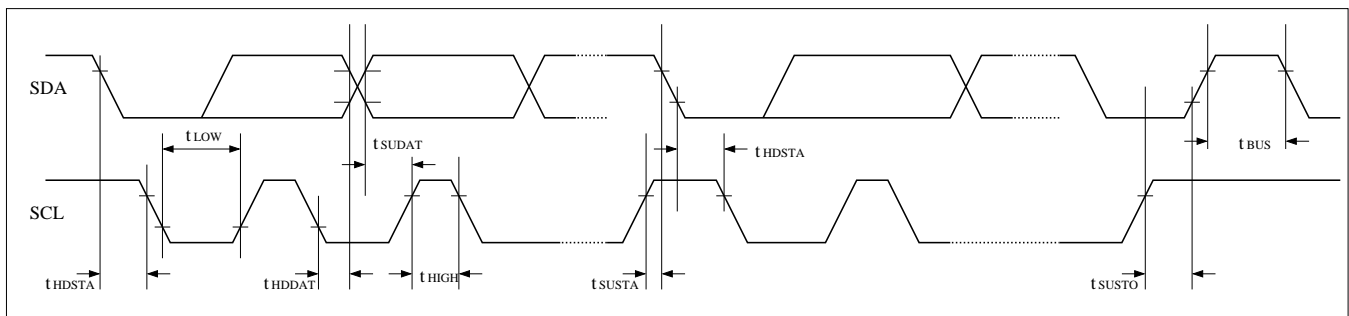
Figure 10. I²C Timing

HSSPI Timing

($T_A = -40\text{ }^{\circ}\text{C}$ to $105\text{ }^{\circ}\text{C}$, $V_{DD} = 1.1\text{V}$ to 1.3V , $V_{DP3} = 3.0\text{V}$ to 3.6V , $V_{DP5} = AV_{DD5} = 3.0\text{V}$ to 5.5V , $DV_{CC} = 3.0\text{V}$ to 5.5V , $V_{SS} = AV_{SS5} = DV_{SS} = 0\text{V}$)

Table 52. HSSPI Interface Timing (Master Mode)

Parameter	Symbol	Value			Unit	Remarks
		Min	Typ	Max		
HSSPI clock frequency		-	-	64	MHz	
Input setup time (HSSPIn_DATAi)	$T_{IS,DATA}$	12.1	-	-	ns	No clock retiming
		5.6	-	-	ns	With clock retiming
Input hold time (HSSPIn_DATAi)	$T_{IH,DATA}$	0	-	-	ns	No clock retiming
		1.5	-	-	ns	With clock retiming
Output delay time (HSSPIn_DATAo)	$T_{OD,DATA}$	-	-	3.8	ns	
Output hold time (HSSPIn_DATAo)	$T_{OH,DATA}$	5	-	-	ns	
Output delay time (HSSPIn_SSELo)	$T_{OD,SSEL}$	-	-	5.05	ns	
Output hold time (HSSPIn_SSELo)	$T_{OH,SSEL}$	0	-	-	ns	

Figure 11. HSSPI Interface Timing

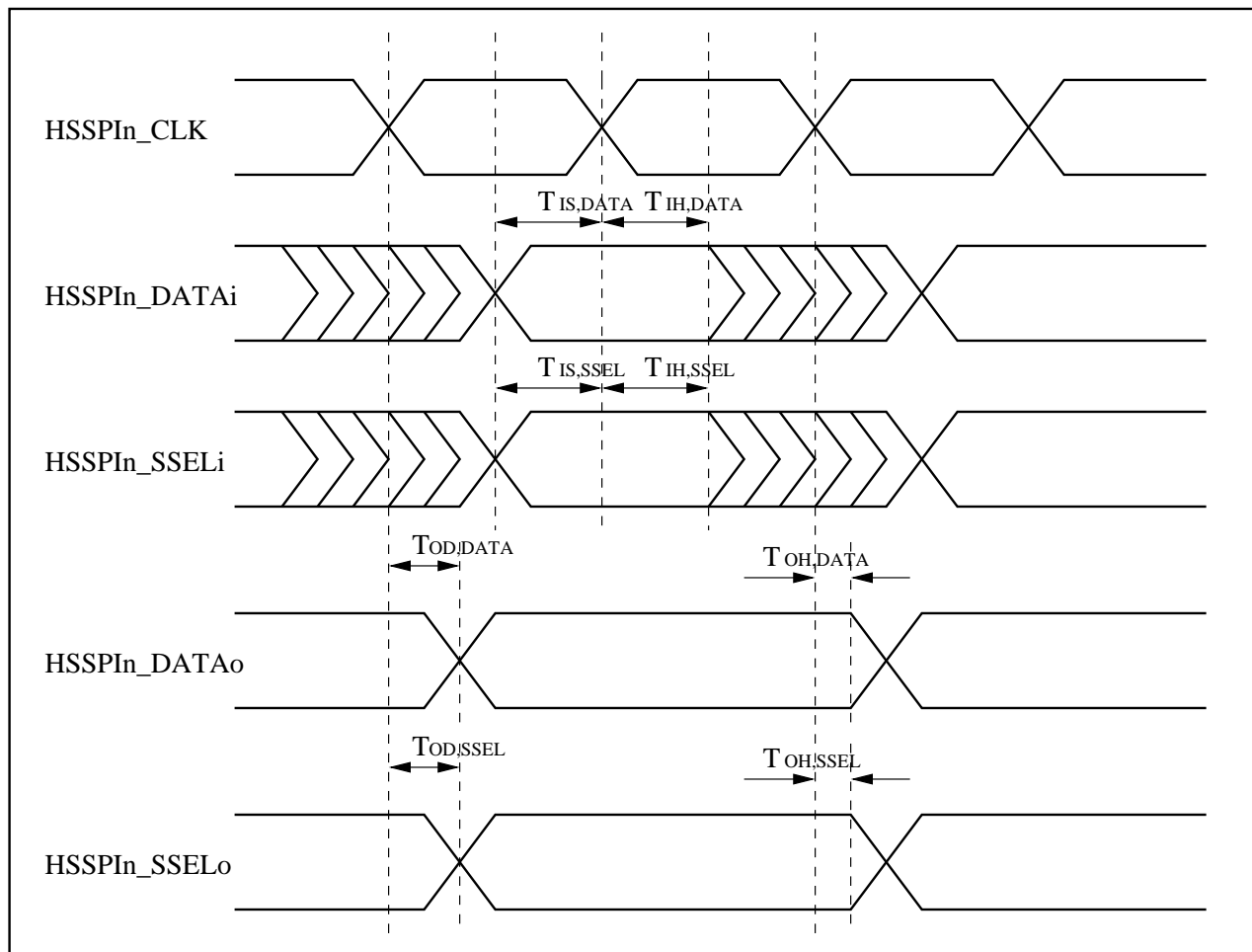

Table 53. HSSPI Interface Timing (Slave Mode)

Parameter	Symbol	Value			Unit	Remarks
		Min	Typ	Max		
HSSPI clock frequency		-	-	25	MHz	
Input setup time (HSSPIn_DATAi)	T _{IS,DATA}	5	-	-	ns	
Input hold time (HSSPIn_DATAi)	T _{IH,DATA}	0	-	-	ns	
Input setup time (HSSPIn_SSELi)	T _{IS,SSEL}	8.2	-	-	ns	
Input hold time (HSSPIn_SSELi)	T _{IH,SSEL}	2	-	-	ns	
Output delay time (HSSPIn_-DATAo)	T _{OD,DATA}	-	-	15.5	ns	
Output hold time (HSSPIn_SSELo)	T _{OH,DATA}	0	-	-	ns	

SPI Timing

(T_A = -40 °C to 105 °C, V_{DD} = 1.1V to 1.3V, V_{DP3} = 3.0V to 3.6V, V_{DP5} = AV_{DD5} = 3.0V to 5.5V, DV_{CC} = 3.0V to 5.5V,

V_{SS} = AV_{SS5} = DV_{SS} = 0V)

For each SPI module, several combinations of I/O pins can be chosen for each SPI signal. The timing depends on the actual combination and is given below as separate values for each possible type of I/O-cell. When I/O/cells of different types are mixed, the worst case table, called “OVERALL SPI Interface timing” must be used.

In Master Mode, using the clock retiming function improves the setup and hold times for input data.

The usable maximum clock frequency depends on the transmission mode (Master to Slave / Slave to Master, using clock-retiming or not). An example for calculation is given below each table.

Table 54. OVERALL SPI Interface Timing

Parameter	Symbol	Master Mode, Non-retimed Clock		Master Mode, Retimed Clock		Slave Mode		Unit
		Min	Max	Min	Max	Min	Max	
Input setup time (SPIn_DATAi)	T _{IS,DATA}	24.9	-	9.9	-	9.8	-	ns
Input hold time (SPIn_DATAi)	T _{IH,DATA}	-6.1 ^[24]	-	9.9	-	9.8	-	ns
Output delay time (SPIn_DATAo)	T _{OD,DATA}	-	12.2	-	12.2	-	41.5	ns
Output hold time (SPIn_DATAo)	T _{OH,DATA}	-5.3 ^[24]	-	-5.3 ^[24]	-	6.3	-	ns
Input setup time (SPIn_SSELi)	T _{IS,SSEL}	-	-	-	-	11.9	-	ns
Input hold time (SPIn_SSELi)	T _{IH,SSEL}	-	-	-	-	7.9	-	ns
Output delay time (SPIn_SSELo)	T _{OD,SSEL}	-	12.1	-	12.1	-	-	ns
Output hold time (SPIn_SSELo)	T _{OH,SSEL}	-4.6 ^[24]	-	-4.6 ^[24]	-	-	-	ns

Example for calculation of max. frequencies for communication of Master (retimed mode) and Slave:

Transmission	Half Period Time	Max. Frequency	Unit
From Master to Slave	T/2 = T _{OD,DATA} (Master) + T _{IS,DATA} (Slave)	20.8	MHz
From Slave to Master	T/2 = T _{OD,DATA} (Slave) + T _{IS,DATA} (Master)	10.5	MHz

Note

24. A negative hold time implies that the clock edge output is delayed with respect to data output. In any case, an external device that will receive data, must use a sampling point that is outside the time interval given by Output hold time and Output delay time.

Table 55. SPI Interface Timing for All Cells of Type RSDS

Parameter	Symbol	Master Mode, Non-retimed Clock		Master Mode, Retimed Clock		Slave Mode		Unit
		Min	Max	Min	Max	Min	Max	
Input setup time (SPIn_DATAi)	$T_{IS,DATA}$	23.8	-	3.1	-	3.0	-	ns
Input hold time (SPIn_DATAi)	$T_{IH,DATA}$	-7.0 ^[25]	-	8.4	-	8.3	-	ns
Output delay time (SPIn_DATAo)	$T_{OD,DATA}$	-	11.6	-	11.6	-	41.5	ns
Output hold time (SPIn_DATAo)	$T_{OH,DATA}$	-4.1 ^[25]	-	-4.1 ^[25]	-	7.6	-	ns
Input setup time (SPIn_SSELi)	$T_{IS,SSEL}$	-	-	-	-	7.8	-	ns
Input hold time (SPIn_SSELi)	$T_{IH,SSEL}$	-	-	-	-	3.8	-	ns
Output delay time (SPIn_SSELo)	$T_{OD,SSEL}$	-	11.5	-	11.5	-	-	ns
Output hold time (SPIn_SSELo)	$T_{OH,SSEL}$	2.6	-	2.6	-	-	-	ns
Example for calculation of max. frequencies for communication of Master (retimed mode) and Slave:								
Transmission		Half Period Time				Max. Frequency		Unit
From Master to Slave		$T/2 = T_{OD,DATA} \text{ (Master)} + T_{IS,DATA} \text{ (Slave)}$				25.9		MHz
From Slave to Master		$T/2 = T_{OD,DATA} \text{ (Slave)} + T_{IS,DATA} \text{ (Master)}$				11.2		MHz

Note

25. A negative hold time implies that the clock edge output is delayed with respect to data output. In any case, an external device that will receive data, must use a sampling point that is outside the time interval given by Output hold time and Output delay time.

Table 56. SPI Interface Timing for All Cells of Type BIDI50

Parameter	Symbol	Master Mode, Non-retimed Clock		Master Mode, Retimed Clock		Slave Mode		Unit
		Min	Max	Min	Max	Min	Max	
Input setup time (SPIn_DATAi)	$T_{IS,DATA}$	24.4	-	5.5	-	5.2	-	ns
Input hold time (SPIn_DATAi)	$T_{IH,DATA}$	-6.1 ^[26]	-	5.4	-	5.3	-	ns
Output delay time (SPIn_DATAo)	$T_{OD,DATA}$	-	9.2	-	9.2	-	30.2	ns
Output hold time (SPIn_DATAo)	$T_{OH,DATA}$	-4.7 ^[26]	-	-4.7 ^[26]	-	6.4	-	ns
Input setup time (SPIn_SSELi)	$T_{IS,SSEL}$	-	-	-	-	8.3	-	ns
Input hold time (SPIn_SSELi)	$T_{IH,SSEL}$	-	-	-	-	2.2	-	ns
Output delay time (SPIn_SSELo)	$T_{OD,SSEL}$	-	7.4	-	7.4	-	-	ns
Output hold time (SPIn_SSELo)	$T_{OH,SSEL}$	0.3	-	0.3	-	-	-	ns
Example for calculation of max. frequencies for communication of Master (retimed mode) and Slave:								
Transmission		Half Period Time				Max. Frequency		Unit
From Master to Slave		$T/2 = T_{OD,DATA} \text{ (Master)} + T_{IS,DATA} \text{ (Slave)}$				31.8		MHz
From Slave to Master		$T/2 = T_{OD,DATA} \text{ (Slave)} + T_{IS,DATA} \text{ (Master)}$				14.0		MHz

Note

26. A negative hold time implies that the clock edge output is delayed with respect to data output. In any case, an external device that will receive data, must use a sampling point that is outside the time interval given by Output hold time and Output delay time.

Table 57. SPI Interface Timing for All Cells of Type SMC

Parameter	Symbol	Master Mode, Non-retimed Clock		Master Mode, Retimed Clock		Slave Mode		Unit
		Min	Max	Min	Max	Min	Max	
Input setup time (SPIn_DATAi)	$T_{IS,DATA}$	24.9	-	4.4	-	4.3	-	ns
Input hold time (SPIn_DATAi)	$T_{IH,DATA}$	-6.8 ^[27]	-	5.3	-	5.2	-	ns
Output delay time (SPIn_DATAo)	$T_{OD,DATA}$	-	8.9	-	8.9	-	32.1	ns
Output hold time (SPIn_DATAo)	$T_{OH,DATA}$	-0.8 ^[27]	-	-0.8 ^[27]	-	7.7	-	ns
Input setup time (SPIn_SSELi)	$T_{IS,SSEL}$	-	-	-	-	6.7	-	ns
Input hold time (SPIn_SSELi)	$T_{IH,SSEL}$	-	-	-	-	3.1	-	ns
Output delay time (SPIn_SSELo)	$T_{OD,SSEL}$	-	7.4	-	7.4	-	-	ns
Output hold time (SPIn_SSELo)	$T_{OH,SSEL}$	1.8	-	1.8	-	-	-	ns

Example for calculation of max. frequencies for communication of Master (retimed mode) and Slave:

Transmission	Half Period Time	Max. Frequency	Unit
From Master to Slave	$T/2 = T_{OD,DATA} \text{ (Master)} + T_{IS,DATA} \text{ (Slave)}$	35.4	MHz
From Slave to Master	$T/2 = T_{OD,DATA} \text{ (Slave)} + T_{IS,DATA} \text{ (Master)}$	13.6	MHz

Note

27. A negative hold time implies that the clock edge output is delayed with respect to data output. In any case, an external device that will receive data, must use a sampling point that is outside the time interval given by Output hold time and Output delay time.

Figure 12. SPI Interface Timing

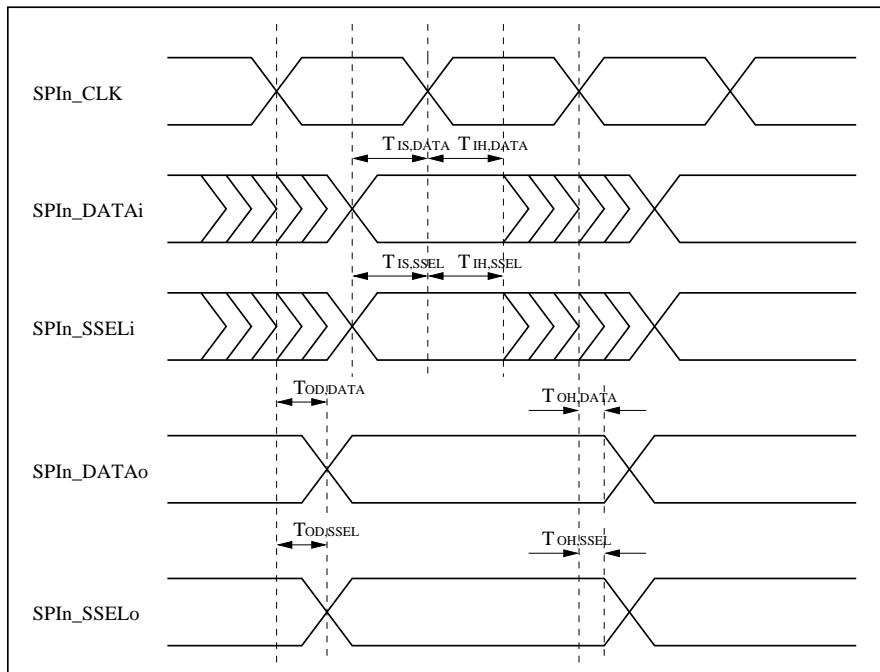

Analog Digital Converter

($T_A = -40\text{ }^\circ\text{C}$ to $105\text{ }^\circ\text{C}$, $3.0\text{V} \leq AV_{RH5}$, $V_{DD} = 1.1\text{V}$ to 1.3V , $V_{DP3} = 3.0\text{V}$ to 3.6V , $V_{DP5} = AV_{DD5} = 3.0\text{V}$ to 5.5V , $DV_{CC} = 3.0\text{V}$ to 5.5V , $V_{SS} = AV_{SS5} = DV_{SS} = 0\text{V}$)

Table 58. Analog Digital Converter

Parameter	Symbol	Pin	Value			Unit	Remarks
			Min	Typ	Max		
Resolution	-	-	-	-	10	bit	-
Total error	-	-	-3	-	+3	LSB	-
Nonlinearity error	-	-	-2.5	-	+2.5	LSB	-
Differential nonlinearity error	-	-	-1.9	-	+1.9	LSB	-
Full scale transition voltage	V_{FST}	ANi	Typ -20	$AV_{RH5} - 1.5\text{ LSB}$	Typ +20	mV	between 1022 and 1023
Zero Transition Voltage	V_{ZT}	ANi	Typ -20	$AV_{SS5} + 0.5\text{ LSB}$	Typ +20	mV	between 0 and 1
Conversion Rate	T_S	pi_jj(ANIN)	353	-	1186	KS/s	-
Comparison Time	T_{COMP}	-	646.8	-	-	ns	Fclk=17MHz, Tclk=58.8ns * 11 clocks
			-	-	2750	ns	$AV_{DD5} = 4.5\text{V} \dots 5.5\text{V}$, Fclk=4MHz, Tclk=250ns * 11 clocks
			-	-	1837	ns	$AV_{DD5} = 3.0\text{V} \dots 4.5\text{V}$, Fclk=6MHz, Tclk=167ns * 11 clocks
Analog input leakage current (during conversion)	I_{AIN}	ANn	-1	-	+1	μA	$T_A = 25\text{ }^\circ\text{C}$, $AV_{SS5} < V_I < AV_{DD5}$, AV_{RH5}
			-3	-	+3	μA	$T_A \leq 105\text{ }^\circ\text{C}$, $AV_{SS5} < V_I < AV_{DD5}$, AV_{RH5}
Analog input voltage range	V_{AIN}	ANn	AV_{SS5}	-	AV_{RH5}	V	-
Reference voltage range	AV_{RH5}	AV_{RH5}	$AV_{DD5} - 0.5$	-	AV_{DD5}	V	-
Power supply current	I_A	AV_{DD5}	-	2	3.4	mA	A/D Converter active
	I_{AH}	AV_{DD5}	-	-	6	μA	25 $^\circ\text{C}$, A/D Converter not operated
			-	-	11	μA	105 $^\circ\text{C}$, A/D Converter not operated
Reference voltage current	I_R	AV_{RH5}	-	0.6	1	mA	A/D Converter active
	I_{RH}	AV_{RH5}	-	-	0.6	μA	A/D Converter not operated
Offset between input channels	-	ANn	-	-	4	LSB	-

Note

28. The accuracy gets worse as $|AV_{RH5}|$ becomes smaller.

Minimum Sampling Time

The minimum sampling time can be calculated from the following formula:

For pins ADC0_AN0..25:

$$T_{\text{samp}} = 7.63 \times [R_{\text{ext}} \times (C_{\text{ext}} + 16\text{pF}) + (R_{\text{ext}} + 1.78\text{kOhm}) \times 18.7\text{pF}]$$

For Pins ADC0_AN26..31:

$$T_{\text{samp}} = 7.63 \times [R_{\text{ext}} \times (C_{\text{ext}} + 16\text{pF}) + (R_{\text{ext}} + 1.78\text{kOhm}) \times 2.6\text{pF} + (R_{\text{ext}} + 3.55 \text{ kOhm}) \times 18.7\text{pF}]$$

Definition of A/D Converter Terms

- Resolution: Analog variation that is recognized by an A/D converter.
- Total error: Difference between the actual value and the ideal value. The total error includes zero transition error, full-scale transition error and nonlinearity error.
- Nonlinearity error: Deviation between a line across zero-transition line (00 0000 0000 <--> 00 0000 0001) and full-scale transition line (11 1111 1110 <--> 11 1111 1111) and actual conversion characteristics.
- Differential linearity error: Deviation of input voltage, which is required for changing output code by 1 LSB, from an ideal value.
- Zero reading voltage: Input voltage which results in the minimum conversion value.
- Full scale reading voltage: Input voltage which results in the maximum conversion value.

Figure 13. Total Error of Digital Output

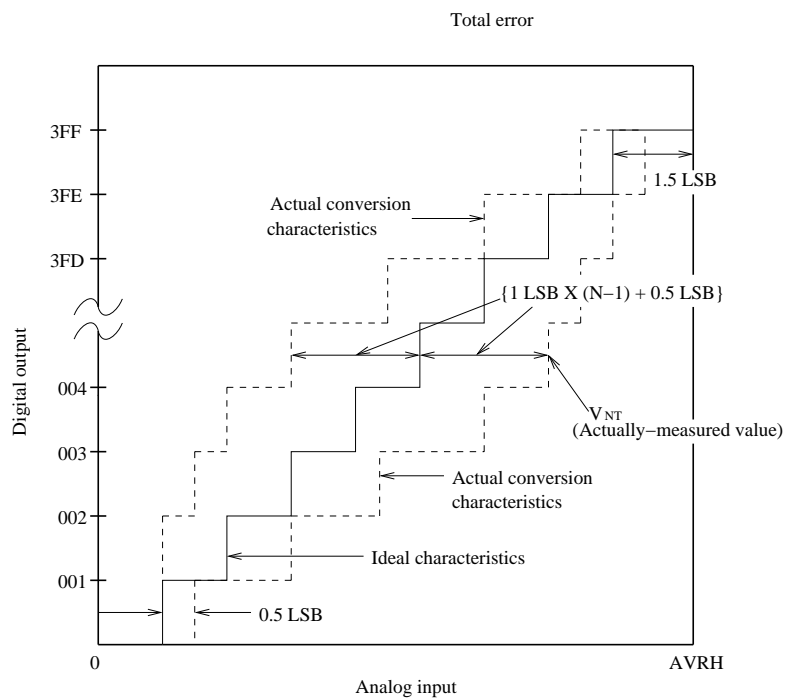

$$\text{Total error of digital output "N"} = \frac{V_{NT} - \{1 \text{ LSB} \times (N-1) + 0.5 \text{ LSB}\}}{1 \text{ LSB}} \text{ [LSB]}$$

$$1 \text{ LSB} = (\text{Ideal value}) \times \frac{\text{AVRH}}{1024} \text{ [V]}$$

N : A/D converter digital output value

V_{OT} (Ideal value) = 0 + 0.5 LSB [V]

V_{FST} (Ideal value) = AVRH - 1.5LB [V]

V_{NT} : A voltage at which digital output transition from (N-1) to N.

FLASH Memory Program/Erase Characteristics

($T_A = -40\text{ }^\circ\text{C}$ to $105\text{ }^\circ\text{C}$, $V_{DD} = 1.1\text{V}$ to 1.3V , $V_{DP3} = 3.0\text{V}$ to 3.6V , $V_{DP5} = AV_{DD5} = 3.0\text{V}$ to 5.5V , $DV_{CC} = 3.0\text{V}$ to 5.5V , $V_{SS} = AV_{SS5} = DV_{SS} = 0\text{V}$)

Table 59. Program/Erase Time for TCFLASH and EEFLASH

Parameter		Value			Unit	Remarks
		Min	Typ ^[29]	Max		
Sector Erase Time	Small Sector	-	0.3	1.1	s	The internal programming time before the erase procedure starts is included.
	Large Sector	-	0.7	3.7	s	
Macro Erase Time	TCFLASH	-	13.6	68	s	
	EEFLASH	-	2.4	8.8	s	
Word Programming Time		-	12	384	μs	

Note

29. Typical definition: $T_A=25^\circ\text{C}$ / $V_{DD}=1.2\text{V}$ / Program/Erase cycle = Immediately after shipment.

Table 60. Program/Erase Cycle and Data Retention Time^[30]

Program/Erase Cycle at Each Sector		Data Retention Time	
Min Value	Unit	Min Value	Unit
1000	cycles	20	years
10000	cycles	10	years
100000	cycles	5	years

Note

30. These values were converted from the technology qualification using Arrhenius equation to translate high temperature measurements into normalized values at $+85^\circ\text{C}$.

Table 61. Execution Time Limit

Parameter	Value	Unit
Program Execution Time limit ^[31]	1.3	ms
Macro Erase Execution Time limit	TCFLASH	187.2
	EEFLASH	63
Sector Erase Execution Time limit ^[32]	7.8	s

Note

31. This is the time it takes for the macro to detect a Hang up 1 error when 1 is to be programmed to a memory cell whose memory value is either 0 or X.

32. See the Hardware Manual for an explanation about Flash Timing Limit Exceeded Flags. The time during Sector Erase Suspend (period from Suspend Command Write Cycle to Resume Command Write Cycle) is not included.

RC Oscillator Frequency

This chapter provides reference values for the RC Configuration Register (SYSC_RCCFGR) settings. The corresponding oscillator is commonly referred to as the “12 MHz RC Oscillator”, because its typical frequency at the central setting is about 12 MHz, with the SYSC_RCCFGR:SFREQ bit set to “1”.

When the SYSC_RCCFGR:SFREQ bit is set to “0”, the central setting corresponds to about 8 MHz.

The default value of SYSC_RCCFGR:SFREQ is “1” and the default value of SYSC_RCCFGR:TRM[7:0] is “0xFF”, so the default frequency setting is 16.9 MHz (typical).

Figure 14. RC Oscillator Frequency at SYSC_RCCFGR:SFREQ = 0

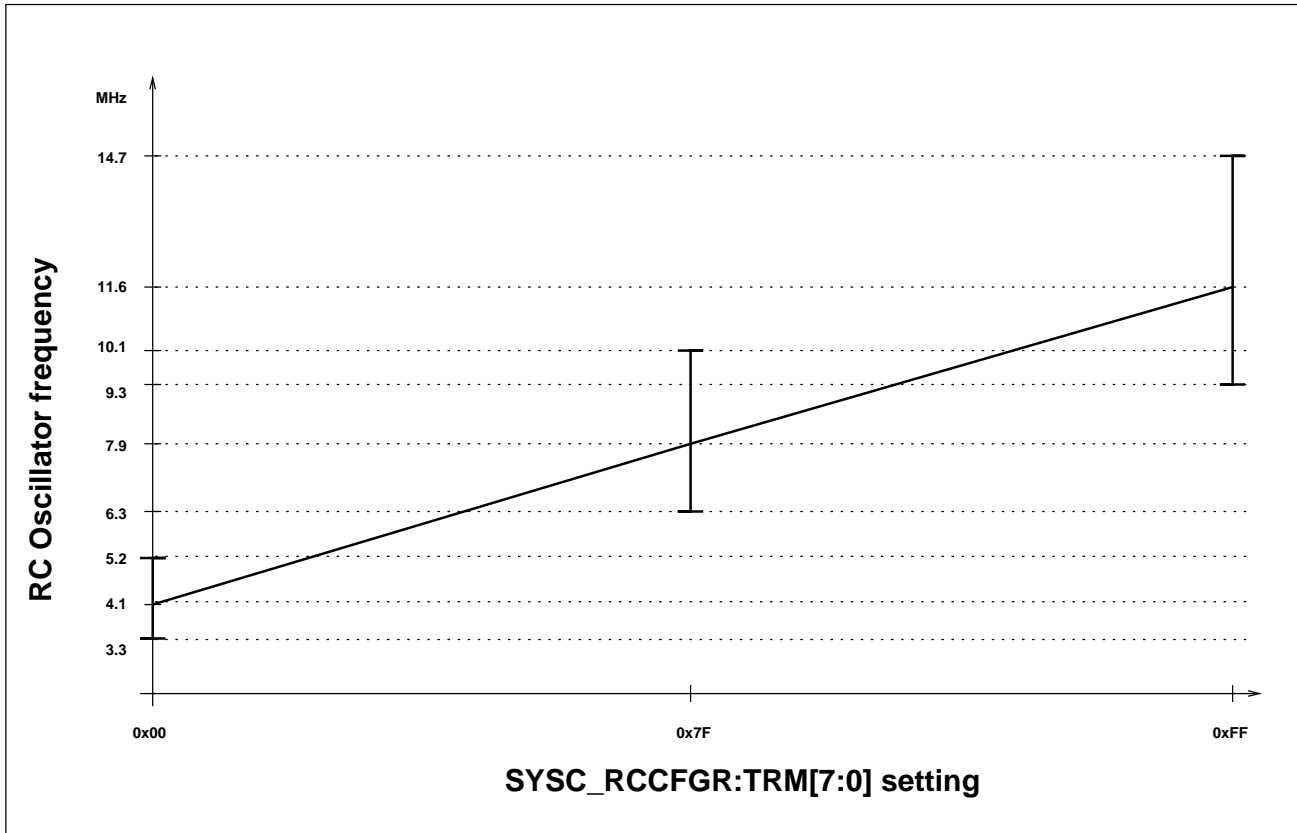

Note

33. The provided function values are not guaranteed and can serve for reference, only. Guaranteed values are listed in [Table 45 on page 257](#).

Figure 15. RC Oscillator Frequency at SYSC_RCCFGR:SFREQ = 1

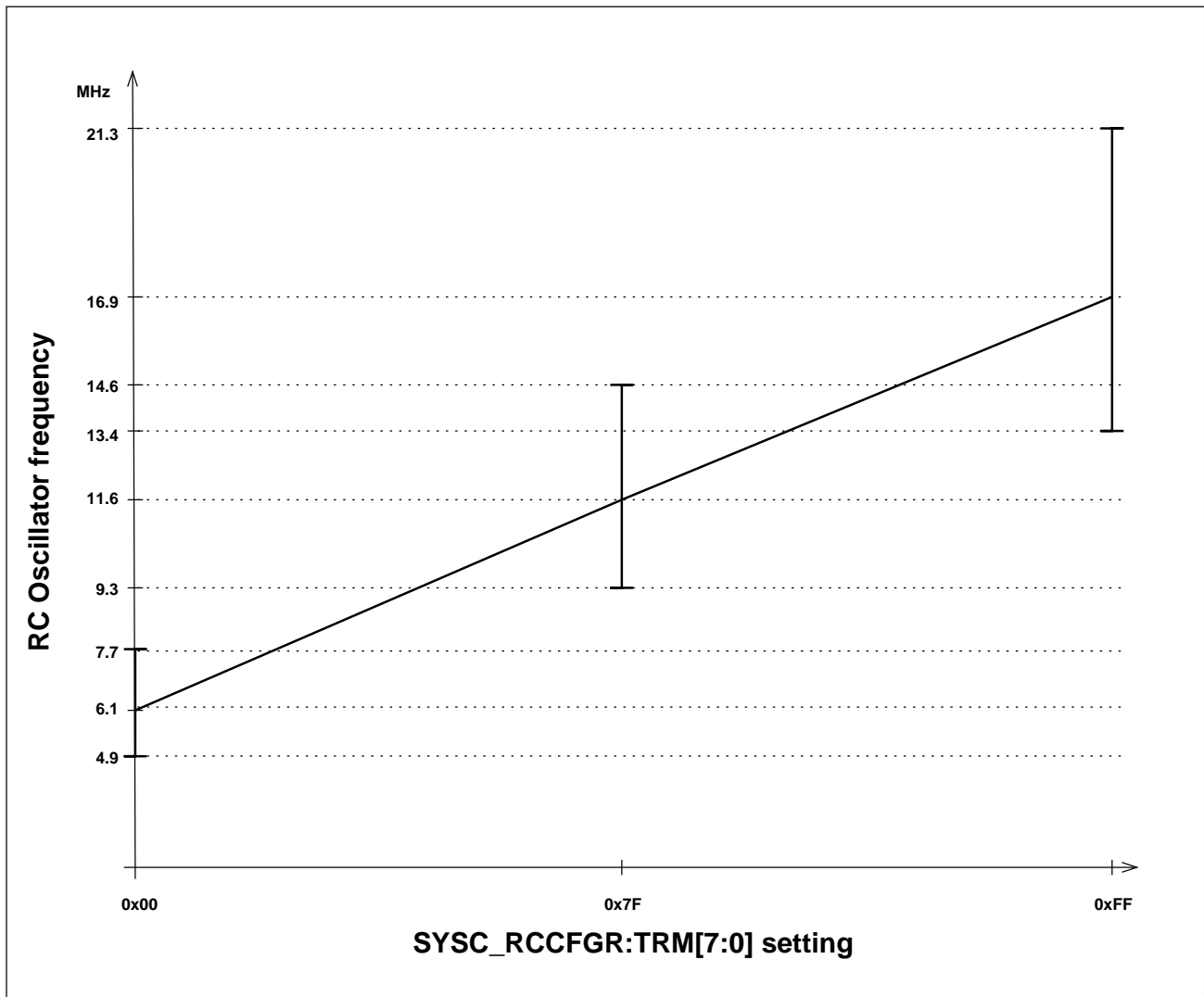

Note

34. The provided function values are not guaranteed and can serve for reference, only. Guaranteed values are listed in [Table 45 on page 257](#).

ESD Structure between Power Domains

There are ESD diodes between VDD, VDP3 and VSS to protect VDD against ESD overvoltage.

Figure 16. ESD Diodes between VDP3, VDD and VSS

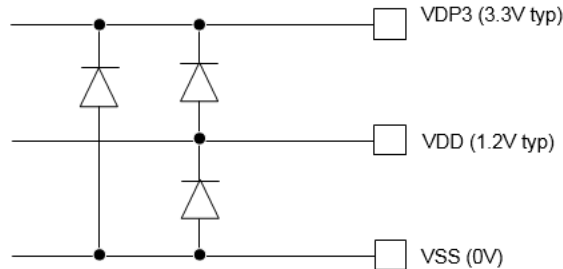

There are ESD diodes between VDD, VDP5 and VSS to protect VDD against ESD overvoltage.

Figure 17. ESD Diodes between VDP5, VDD and VSS

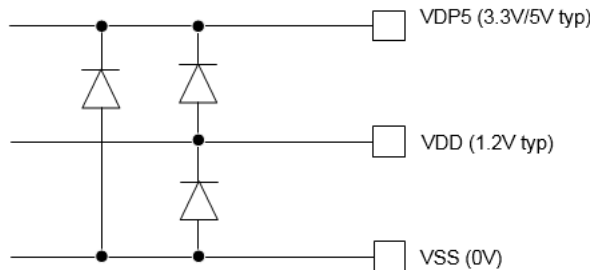

There are ESD diodes between AVSS5, VDP5 and VSS to protect AVSS5 and VSS against ESD overvoltage.

Figure 18. ESD Diodes between VDP5, AVSS5 and VSS

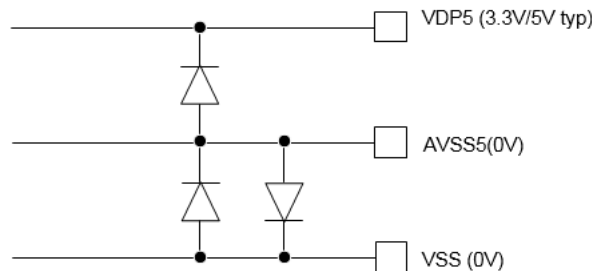

There are ESD diodes between AVDD5 and AVSS5 to protect AVDD5 and AVSS5 against ESD overvoltage.

Figure 19. ESD Diodes between AVDD5 and AVSS5

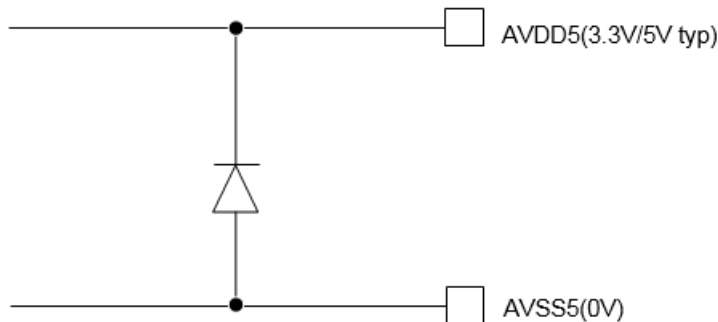

There are ESD diodes between DVSS, DVCC (SMC supply) and VSS to protect DVSS and VSS against ESD overvoltage.

Figure 20. ESD Diodes between DVCC, DVSS and VSS

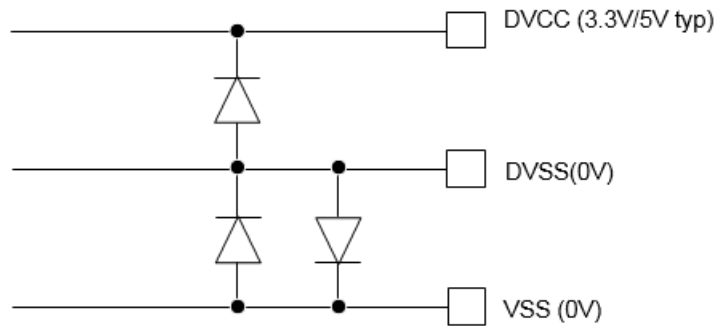

There are ESD diodes between VDP5, AVDD5 and VSS to protect AVDD5 against ESD overvoltage.

Figure 21. ESD Diodes between VDP5, AVDD5 and VSS

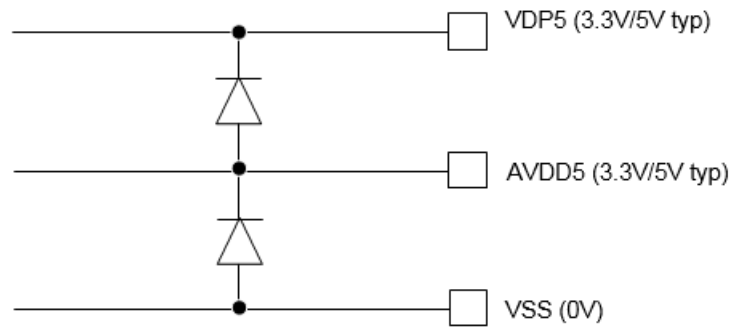

Procedures

Boundary Scan

Boundary scan is supported using standard IEEE 1149.1 JTAG interface. A 5-pin JTAG connection is available on QFP-176 (production variant). Instruction register supported is 6-bits wide, and the standard instructions listed in [Table 62 on page 275](#) are supported. Any other value of instruction register is reserved, and should not be entered. Entering reserved values can result in indeterminate operation.

Boundary scan mode may be entered by setting pins MODE = “1” and MD[0] = “0”.

Table 62. Standard Instructions

Instruction Code (in Binary)	Instruction	Accessible Data Register	Remarks
'000000'	EXTEST	Boundary scan chain	
'000001'	SAMPLE	Boundary scan chain	
'000010'	PRELOAD	Boundary scan chain	
'000011'	IDCODE	Device ID code register	For CY9EF226, IDCODE is 0x0F159009
'000100'	USERCODE	Device user code register	For CY9EF226, USERCODE is 32-bits long, and is 0xC4202012
'000101'	HIGHZ	Boundary scan chain	
'000110'	CLAMP	Boundary scan chain	
'010001'	IO_CNTRL	IO Control register	Command must be followed by 16bit data value: 0x04pp, where “pp” is a pin control setting from Table 63 .
'111111'	BYPASS	Bypass register	

Table 63. IO Control (IO_CNTRL) Register

IO_CNTRL															
15	14	13	12	11	10	9	8	7	6	5	4	3	2	1	0
reserved	reserved	reserved	reserved	reserved	SEL	I2C	reserved	reserved	reserved	DCPDN	DCPUP	OUTDR[1]	OUTDR[0]	PITILS[1]	PITILS[0]
R0W0	R0W0	R0W0	R0W0	R0W0	RW	RW	R0W0	R0W0	R0W0	RW	RW	RW	RW	RW	RW
0	0	0	0	0	0	0	0	0	0	0	0	0	0	0	0

Table 64. IO Control (IO_CNTRL) Register Bits

Bit Position	Bit Field Name	Bit Description																																				
[15:11]	reserved	Reserved. Always write 0 to these bits.																																				
[10]	SEL	Selection of DCPDN, DCPUP, OUTDR and PITILS "0": IO_CNTRL[5:0] are disabled. Input buffers are disabled. "1": IO_CNTRL[5:0] will control IO pads																																				
[9]	I2C	Extends IO_CNTRL[3:2], but for I2C IO cell only (see below) "0" : set I2C cell to value selected by IO_CNTRL[3:2] "1" : set I2C cell to "pseudo open drain"																																				
[8:6]	reserved	Reserved. Always write 0 to these bits.																																				
[5]	DCPDN	Control all pull-down resistors of the IOs Valid if bit [10] is "1" "0" : All pull-downs are disabled "1" : All pull-downs are enabled																																				
[4]	DCPUP	Control all pull-up resistors of the IOs Valid if bit [10] is "1" "0" : All pull-ups are disabled "1" : All pull-ups are enabled																																				
[3:2]	OUTDR	Output driver strength Valid if bit 10 is "1" Bit selection depends on IO cell type (IO Circuit Types on page 68)																																				
		<table border="1"> <thead> <tr> <th>OUTDR[1:0]</th> <th>BIDI50</th> <th>BIDI33</th> <th>SMC</th> <th>I2C</th> <th>RSDS/TTL33</th> </tr> </thead> <tbody> <tr> <td>"00"</td> <td>±5mA±</td> <td>±12mA</td> <td>±5mA</td> <td>±5mA</td> <td>±5mA</td> </tr> <tr> <td>"01"</td> <td>±2mA</td> <td>±12mA</td> <td>±2mA</td> <td>±2mA</td> <td>±2mA</td> </tr> <tr> <td>"10"</td> <td>±1mA</td> <td>±12mA</td> <td>±1mA</td> <td>±1mA</td> <td>±10mA</td> </tr> <tr> <td>"11"</td> <td>-</td> <td>-</td> <td>±30mA</td> <td>-</td> <td>±20mA</td> </tr> <tr> <td>x + bit[9] = "1"</td> <td>-</td> <td>-</td> <td>-</td> <td>pseudo open drain</td> <td>-</td> </tr> </tbody> </table>	OUTDR[1:0]	BIDI50	BIDI33	SMC	I2C	RSDS/TTL33	"00"	±5mA±	±12mA	±5mA	±5mA	±5mA	"01"	±2mA	±12mA	±2mA	±2mA	±2mA	"10"	±1mA	±12mA	±1mA	±1mA	±10mA	"11"	-	-	±30mA	-	±20mA	x + bit[9] = "1"	-	-	-	pseudo open drain	-
		OUTDR[1:0]	BIDI50	BIDI33	SMC	I2C	RSDS/TTL33																															
		"00"	±5mA±	±12mA	±5mA	±5mA	±5mA																															
		"01"	±2mA	±12mA	±2mA	±2mA	±2mA																															
		"10"	±1mA	±12mA	±1mA	±1mA	±10mA																															
"11"	-	-	±30mA	-	±20mA																																	
x + bit[9] = "1"	-	-	-	pseudo open drain	-																																	
[1:0]	PITILS	Pin Input Test Input Level Select Valid if bit 10 is "1" "00": Hysteresis "01": Automotive "10": TTL "11": CMOS																																				

Note

35. When Bit[10] = "0", all input buffers are disabled in Boundary Scan mode. Then, input of data via external pins to the BSR (Boundary Scan Register) is impossible. Therefore, the minimum setting to allow input to the BSR is 0x0400.

Procedure for Configuration for Port Input:

1. MODE clipped to '1' and MD[0] clipped to '0'.
2. Release JTAG_NRST and RSTX.
3. JTAG-Instruction IO_CNTRL (010001).
4. Set IO_CNTRL-reg 10th bit: (For example, 0000010000000000).
5. JTAG-Instruction SAMPLE > Port Input.

The serial chain starts with the I/O closest to JTAG_TDI pin, and ends with the I/O closest to the JTAG_TDO pin.

Flash Parallel Programming

Flash Parallel Programming (FPP) mode is supported to allow for quick programming/erase of embedded flashes. In this mode program or erase of flash is done using a flash memory programmer directly via external pins. Flash programming is done either in 8-bit or 16-bit mode through the command sequence. Refer Section 4 of Tightly Coupled Flash Chapter of HWM for details of Flash program/erase command sequence. Flash addressing in this mode is direct physical addressing, with higher order bits used for flash macro selection.

In CY9EF226 device, there are 2 flash macros of 1MB+64KB size and 1 flash macro of 64KB. Details about flash macro sectoring are shown in [Table 65](#).

Table 65. Flash Sector Information

Flash Macro	Macro size	Small Sectors (8KB/sector)	Large sectors (64KB/sector)
TCFLASH macro 0	1MB + 64KB	8	16
TCFLASH macro 1	1MB + 64KB	8	16
EEFLASH macro	64KB	8	Not Available

Details about mapping of flash pins to external pins are presented in [Table 66](#).

Table 66. Flash Pin Mapping to External Pins

External Pin Number (QFP-176)	External Pin Name	Flash Macro Pin	Function
93	P1_47	DFSEL	Flash select signal. Refer Table 72 on page 284 for additional details regarding use of DFSEL.
3	X0	FCLK	Flash clock
1	MODE	MODE	Mode pin to enter test mode (MODE = '1')
7	RSTX	RSTX	Device Reset pin
11	P1_30	SMD[0]	Set to '1' when entering FPP mode.
12	P1_31	SMD[1]	Set to '1' when entering FPP mode.
13	P1_32	MD[0]	Set to '1' when entering FPP mode.
14	P1_33	MD[1]	Set to '1' when entering FPP mode.
15	P1_34	MD[2]	Set to '1' when entering FPP mode.
16	P1_35	FRSTX	External flash reset pin 0: Reset 1: Normal operation
17	P1_36	FRSTRX	External power enable to flash macro at 5V 0: Reset 1: Normal operation
99	P1_00	CEX	Flash macro enable 0: Macro recognizes read/write commands 1: Neither read operation nor write operation is executed
20	P1_61	WEX	Write enable 0: Macro recognizes read commands 1: Macro recognizes write commands
21	P1_62	BYTEX	Byte access enable 0: 8-bit write mode 1: 16-bit write mode
136	P0_40	OEX	Direction control signal for shared pins like data and ECC data 0: Shared data/ECC data pins are in output mode 1: Shared data/ECC data pins are in input mode limitation applies for read (output) data (they appear as logical ORed of all FLASHs)

Table 66. Flash Pin Mapping to External Pins (Continued)

External Pin Number (QFP-176)	External Pin Name	Flash Macro Pin	Function
100	P1_01	FA[00]	Flash address. Refer to Table 69 on page 282 for additional details regarding use of FA[21].
101	P1_02	FA[01]	
102	P1_03	FA[02]	
103	P1_04	FA[03]	
104	P1_05	FA[04]	
105	P1_06	FA[05]	
106	P1_07	FA[06]	
109	P1_08	FA[07]	
110	P1_09	FA[08]	
111	P1_10	FA[09]	
112	P1_11	FA[10]	
113	P1_12	FA[11]	
114	P1_13	FA[12]	
115	P1_14	FA[13]	
116	P1_15	FA[14]	
119	P1_16	FA[15]	
120	P1_17	FA[16]	
121	P1_18	FA[17]	
122	P1_19	FA[18]	
123	P1_20	FA[19]	
124	P1_21	FA[20]	
125	P1_22	FA[21]	
126	P1_23	FA[22]	
150	P2_32	DIN[00]/DOR[00]	Shared data input/output. Refer Section /
151	P2_33	DIN[01]/DOR[01]	
152	P2_34	DIN[02]/DOR[02]	
153	P2_35	DIN[03]/DOR[03]	
154	P2_36	DIN[04]/DOR[04]	
155	P2_37	DIN[05]/DOR[05]	
158	P2_38	DIN[06]/DOR[06]	
159	P2_39	DIN[07]/DOR[07]	
160	P2_40	DIN[08]/DOR[08]	
161	P2_41	DIN[09]/DOR[09]	
162	P2_42	DIN[10]/DOR[10]	
163	P2_43	DIN[11]/DOR[11]	
164	P2_48	DIN[12]/DOR[12]	
165	P2_49	DIN[13]/DOR[13]	
168	P2_50	DIN[14]/DOR[14]	
169	P2_51	DIN[15]/DOR[15]	

Table 66. Flash Pin Mapping to External Pins (Continued)

External Pin Number (QFP-176)	External Pin Name	Flash Macro Pin	Function
141	P0_43	EDIN[00]/EDOR[00]	Shared ECC data input/output Refer Section /
142	P0_44	EDIN[01]/EDOR[01]	
143	P0_45	EDIN[02]/EDOR[02]	
144	P0_46	EDIN[03]/EDOR[03]	
145	P0_47	EDIN[04]/EDOR[04]	
148	P0_48	EDIN[05]/EDOR[05]	
149	P0_49	EDIN[06]/EDOR[06]	
137	P0_41	ECCA	ECC write access enable 0: ECC write disable 1: ECC write enable
134	P0_24	RDYR	Internal voltage ready/busy flag at 5V 0: Busy 1: Ready
140	P0_42	RDY	FLASH internal state at PPROGRAM, ERASE and power on 0: busy 1: ready Output behaves as open drain (needs pull-up) to support programming multiple devices at once.
135	P0_25	RD64	64-bit read enable 0: 32-bit read mode 1: 64-bit read mode

Timing requirements for flash signals are provided in Figure 22 and Table 67.

Figure 22. Flash Timing Parameters

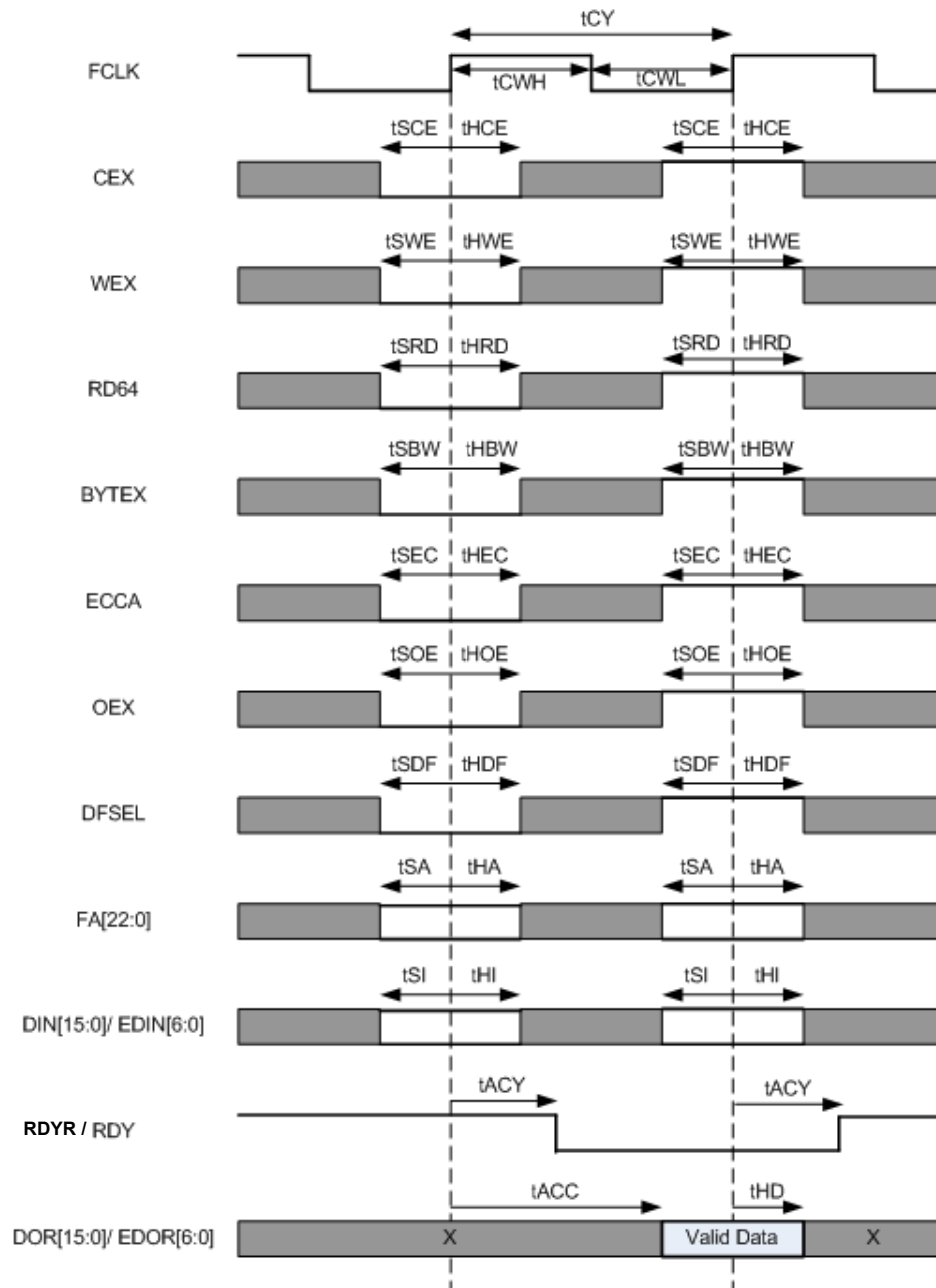

Table 67. Flash Timing Requirements

Parameter	Symbol	Min. Value	Unit
Cycle Time	tCY	100	ns
Clock High Time	tCWH	25	ns
Clock Low Time	tCWL	25	ns
CEX setup	tSCE	20	ns
CEX hold	tHCE	20	ns
WEX setup	tSWE	20	ns
WEX hold	tHWE	20	ns
RD64 setup	tSRD	20	ns
RD64 hold	tHRD	20	ns
BYTEX setup	tSBW	20	ns
BYTEX hold	tHBW	20	ns
ECCA setup	tSEC	20	ns
ECCA hold	tHEC	20	ns
OEX setup	tSOE	20	ns
OEX hold	tHOE	20	ns
DFSEL setup	tSDF	20	ns
DFSEL hold	tHDF	20	ns
FA setup	tSA	20	ns
FA hold	tHA	20	ns
DIN/EDIN setup	tSI	20	ns
DIN/EDIN hold	tHI	20	ns
RDY output delay	tACY	80	ns
DOR/EDOR output delay	tACC	80	ns
DOR/EDOR hold	tHD	5	ns

Notes

- 36. Input Data should change at falling edge of X0 clock.
- 37. Output data should be sampled at next rising edge of X0 clock.

Memory Map

This flash memory consists of 16 sectors of 64k byte (large sector) and 8 sectors of 8k byte (small sector).

A large sector is composed of 16k word, and a small sector is composed of 2k word. 1word data width is 39 bit (regular bit: 32 bit + ECC parity bit: 7bit) for both large sector and small sector.

Address Space and Memory Cell Select Address Assignment

The select address assignment is listed below. The assignment in the large sector and that in the small sector differ.

When the small sector (FA[20]=0) is selected, no matter what the values (1/0) of FA[19:16] are, the memory cell to be used is determined according to the values of FA[15:0].

- Large Sector (0x100000 ~ 0x1FFFFFF)

Table 68. Large Sector (0x100000 ~ 0x1FFFFFF)

FA[20]	FA[19:16]	FA[15:2]	FA[1:0]
1	Sector selection (16large sector)	Select a word in the sector (16,384word)	Select a Byte in the word(32bit)

- In read or program mode, an address pin input is ignored as shown below. Apply a given value (1/0) to the corresponding pin. For the correspondence between data output pins and data input pins, see [Output Data Table](#) and [Input Data Table](#).

8 bit program mode (BYTEX=0): Ignore none of FA[20:0] and input 8bit selected in FA[20:0].

16 bit program mode (BYTEX=1): Ignore FA[0] and input 16 bit.

- FPP mode can only output 8 or 16 bit.
- RD64 should always be kept 0.
- BYTEX=0: DQ[7:0] is used
- BYTEX=1: DQ[15:0] is used

- Small Sector (0x0*0000 ~ 0x0*FFFF)

Table 69. Small Sector (0x0*0000 ~ 0x0*FFFF)

FA[20]	FA[15:13]	FA[12:2]	FA[1:0]
0	Sector selection (8small sector)	Select a word in the sector (2,048word)	Select a Byte in the word(32bit)

The left asterisk mark in the value indicates a given value (except an indeterminate value).

- When small sector is selected (FA[20]=0), input a given value (1/0) to FA[19:16] pins.
- In read or program mode, an address pin input is ignored as shown below. Apply a given value (1/0) to the corresponding pin. For the correspondence between data output pins and data input pins, see [Output Data Table](#) and [Input Data Table](#).

8bit program mode (BYTEX=0): Ignore none of FA[20,15:0] and input 8bit selected in FA[20,15:0].

16bit program mode (BYTEX=1): Ignore FA[0] and input 16bit.

- FPP mode can only output 8 or 16 bit.
- RD64 should always be kept 0.
- BYTEX=0: DQ[7:0] is used
- BYTEX=1: DQ[15:0] is used

Output Data Table

In 32 bit read mode, the data is output to different output pins based on the sector-selected lowest address values as shown in [Table 70](#).

Table 70. Data Output Correspondence Table in Read Bit Modes

Bit Mode	RD64	Select Address			Data output pins					
		FA[#]	FA[1]	FA[0]	DOR[63:32]	DOR[31:0]	EDOR[13:7]	EDOR[6:0]	DOV[15:8]	DOV[7:0]
64bit	1	1/0	1/0	1/0	Odd. Sector Regular bit 31-0	Even Sector Regular bit 31-0	Odd. Sector Parity bit 6-0	Even Sector Parity bit 6-0	Status 7-0	Status 7-0
32bit	0	1	1/0	1/0	Odd. Sector Regular bit 31-0	X	Odd. Sector Parity bit 6-0	X	Status 7-0	Status 7-0
		0	1/0	1/0	X	Even Sector Regular bit 31-0	X	Even Sector Parity bit 6-0	Status 7-0	Status 7-0

- FA[#] indicates the lowest bit of sector-selected address, i.e., FA[16] when the large sector is selected (FA[n]=1), and FA[13] when the small sector is selected (FA[n]=0).
- Even Sector indicates an even-number-th sector (large sector FA[16]=0 / small sector FA[13]=0). Odd Sector indicates an odd-number-th sector (large sector FA[16]=1 / small sector FA[13]=1) "even-number-th" and "odd-number-th" respectively indicate the even number and odd number in Sector No. values shown in [Memory Map](#).

Input Data Table

In 8 bit program mode, the data of the different input pins based on the FA[0] values is programmed as shown in [Table 71](#).

When ECCA=1 is input at the program data input, the data is written to ECC parity bit as well as Regular bit. When ECCA=0 is input at the program data input, the data is written only to Regular bit. In this case, EDIN[6:0] input value is "don't care," and regardless of the value, no value is written to ECC parity bit. In the case of erase operation, regardless of input values to ECCA, both Regular bit and ECC parity bit are erased together.

Table 71. Correspondence Table of Data Input and Memory Cell Bit in Program Bit Modes

Bit Mode	BYTEX	Write Cycle	Select Address				Data Input pins			
			FA[#]	FA[1]	FA[0]	ECCA	DIN[15:8]	DIN[7:0]	EDIN[6:0]	
16bit	1	Command data input	1/0	1/0	1/0	1/0	any	command data 7-0	any	
		Program data input	1	1	1/0	1	Odd. Sector Regular bit 31-24	Odd. Sector Regular bit 23-16	Odd. Sector Parity bit 6-0	
						0	any	any		
			0	1/0	1	Odd. Sector Regular bit 15-8	Odd. Sector Regular bit 7-0	Odd. Sector Parity bit 6-0		
					0	any	any			
		0	1/0	1	1	Even Sector Regular bit 31-24	Even Sector Regular bit 23-16	Even Sector Parity bit 6-0		
					0	any	any			
			0	1/0	1	1	Even Sector Regular bit 15-8	Even Sector Regular bit 7-0	Even Sector Parity bit 6-0	
0	any					any				
8bit	0	Command data input	1/0	1/0	1/0	1/0	any	command data 7-0	any	
		Program data input	1	1	1	1	Odd. Sector Regular bit 31-24	any	Odd. Sector Parity bit 6-0	
						0	any	Odd. Sector Regular bit 23-16	Odd. Sector Parity bit 6-0	
				0	1	1	1	Odd. Sector Regular bit 15-8	any	Odd. Sector Parity bit 6-0
							0	any	Odd. Sector Regular bit 7-0	Odd. Sector Parity bit 6-0
			0	1	1	1	Even Sector Regular bit 31-24	any	Even Sector Parity bit 6-0	
						0	any	Even Sector Regular bit 23-16	Even Sector Parity bit 6-0	
				0	1	1	1	Even Sector Regular bit 15-8	any	Even Sector Parity bit 6-0
							0	any	Even Sector Regular bit 7-0	Even Sector Parity bit 6-0
			0	1	1	1	any	any	any	
						0	any	any	any	
				0	1	1	1	any	any	any
							0	any	any	any

- "Any" a value of either 1 or 0.
- FA[#] indicates the lowest bit of sector-selected address, i.e. FA[16] when the large sector is selected (FA[n]=1), and FA[13] when the small sector is selected (FA[n]=0). When programming, in both 8bit mode and 16bit mode, program/erase operation is executed per one sector specified by the selected addresses.
- Program Data Input means the 4th write cycle of a program command in the normal operation state and the 2nd write cycle of a program command in the Unlock-bypass state.
- Command Data Input means the write cycles in the write command sequence other than those mentioned above in which program data is input.

Flash Macro Selection and Address Mapping in FPP

The TC-Flash macro can be accessed using the address decoding scheme as mentioned in [Table 72](#).

Table 72. Flash Macro Selection

DFSEL	FA[21]	Flash Macro Selection
0	0	TCFLASH macro 0
0	1	TCFLASH macro 1

However, device level memory map differs from actual physical address to flash macro. Hence, it is expected that the flash parallel programmer must translate CPU mode addressing to actual physical address to flash. Hence, CPU execution code must be located at physical addresses that are mapped to the CPU mode addresses.

Translation of CPU mode address to actual physical address differs based on whether small or large sectors are accessed.

[Table 73](#) provides the address translation for small sectors of TCFLASH macro 0 and 1.

Table 73. TCFlash Small Sectors Address Translation

Flash Address Bit	CPU Address Bit
FA[21]	0
FA[20]	0
FA[19]	0
FA[18]	0
FA[17]	0
FA[16]	0
FA[15]	ADDR[15]
FA[14]	ADDR[14]
FA[13]	ADDR[02]
FA[12]	ADDR[13]
FA[11]	ADDR[12]
FA[10]	ADDR[11]
FA[09]	ADDR[10]
FA[08]	ADDR[09]
FA[07]	ADDR[08]
FA[06]	ADDR[07]
FA[05]	ADDR[06]
FA[04]	ADDR[05]
FA[03]	ADDR[04]
FA[02]	ADDR[03]
FA[01]	ADDR[01]
FA[00]	ADDR[00]

Note

38. Small sectors are interleaved (even and odd sectors). Even numbered sectors provide lower 4 byte and odd numbered sectors provide upper 4 byte of a 64 bit FLASH line.

Table 74 provides the address translation for large sectors of TCFlash.

Table 74. TCFlash Large Sectors Address Translation

Flash Address Bit	CPU Address Bit
FA[21]	ADDR[03]
FA[20]	1
FA[19]	ADDR[20]
FA[18]	ADDR[19]
FA[17]	ADDR[18]
FA[16]	ADDR[02]
FA[15]	ADDR[17]
FA[14]	ADDR[16]
FA[13]	ADDR[15]
FA[12]	ADDR[14]
FA[11]	ADDR[13]
FA[10]	ADDR[12]
FA[09]	ADDR[11]
FA[08]	ADDR[10]
FA[07]	ADDR[09]
FA[06]	ADDR[08]
FA[05]	ADDR[07]
FA[04]	ADDR[06]
FA[03]	ADDR[05]
FA[02]	ADDR[04]
FA[01]	ADDR[01]
FA[00]	ADDR[00]

Note

- 39. Large sectors of TCFLASH are 4-times interleaved for best read performance (see also HW/Manual fig. 9.3-2 TCFLASH sector/address mapping - CPU mode).
- 40. Large sectors are interleaved (even and odd numbered sectors). Even numbered sectors provide lower 4 byte and odd numbered sectors provide upper 4 byte of a 64 bit FLASH line.
- 41. Address space is interleaved between TCFLASH0 and TCFLASH1. TCFLASH0 keeps lower 8 byte and TCFLASH1 keeps upper 8 byte of a 128 bit FLASH line (2 FLASHs are read in parallel).

The EEFlash macro can not be programmed in FPP mode with respect to SHE security.

Flash Power On Sequence

Prior to entering flash parallel programming mode, the sequence mentioned below must be followed:

1. Apply following constant pin setting: MODE = 1 and MD[2:0] = 111. The pins for MD[2:0] have pull-up, thus can be left open.
2. Assert RSTX = 0 and JTAG_nTRST = 0. The pin JTAG_nTRST has pull-down, so it will be kept in reset by the device if it is left open. Asserting FRSTX = 0 and FRSTRX = 0 is optional. This is done internally at device startup.
3. Ramp up the power supply (please refer to device specific datasheet for power supply sequence) and wait till all power supplies (VDP5, VDP3 & VDD) are stable
4. Wait for at least 500ns after all power supplies are stable.
5. De-assert RSTX= 1, also deassert FRSTX = 1 and FRSTRX = 1 if those were asserted before.
6. Wait until Flash Parallel Programming mode is entered by the bootROM program (boot time). Wait time should be >=2.5 ms after RSTX release. Note that the wait time is necessary because RDY pin is High-Z before FPP mode is entered. Looking at RDY (which has pull-up) alone would cause mis-interpretation before that time is elapsed.
7. Flash access is possible after RDY pin goes to "1". Clock supply is needed for monitoring RDY.

RDY pin is pseudo open drain and thus needs a pull-up resistor. That makes it possible to program multiple devices at once by using wired-AND of the RDY outputs, to detect when slowest device becomes ready.

Failure to follow the above sequence can result in indeterminate behavior. Once the above sequence is completed, flash parallel programming mode may be entered.

Flash parallel programming mode standard usage:

Entering FPP by releasing RSTX while keeping.

- MODE = '1'
- MD[1] = '1', MD[0] = '1'
- SMD[2] = '1', SMD[1] = '1', SMD[0] = '1'

Furthermore, Flash parallel programming mode may be entered using 2 options:

1. Setting MCFG_DTAR:FPPREQ
2. Setting MCFG_TSR:MD='XXX111', and MCFG_TSR:SMD='11111'

Once flash parallel mode is requested, the bit SYSC_MCR:FPPEN is set, which enables entry to FPP mode. However, it must be noted that FPP access must also be enabled in Security Description Record (SDR) (see HWM).

The external programmer must also take care to program ECC bits for flash data contents. This also applies to flash erase, where bit flipping (XOR with 0x73) is to be performed to handle ECC checking for erased flash.

Figure 23. Power On Sequence

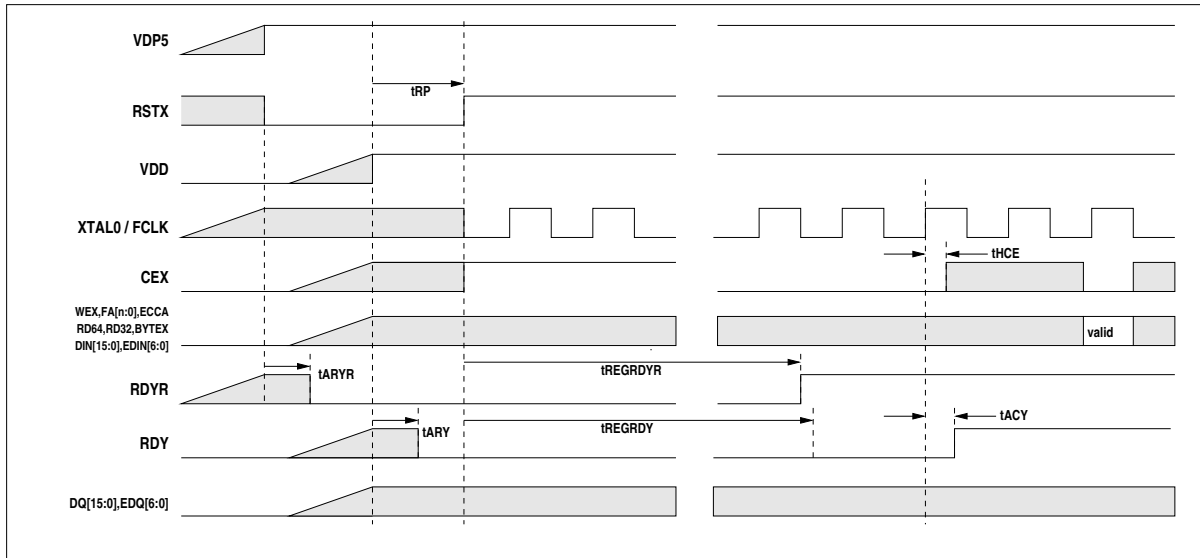

Recommendation: FRSTX = FRSTRX = '1'

Table 75. Timing Parameters Related to Power ON Sequence

Parameter	Symbol	Value		Unit
		Min	Max	
Hardware Reset(FRSTX=0) period	t_{RP}	440	-	ns
Hardware Reset(RSTX=0) period	t_{RP}	500	-	ns
FRSTRX fall to RDYR fall access	t_{ARYR}	-	80	ns
FRSTX fall to RDY reset	t_{ARY}	-	80	ns
FRSTRX rise to RDYR rise access	$t_{AREGRDYR}$	-	80	ns
FRSTRX rise to RDY rise access	$t_{AREGRDY}$	-	80	ns

Debug and Trace

A standard 5-pin JTAG interface is supported for debug and trace. Conventional debug (core halted, and invasive) as well as trace debug (core not halted and non-invasive) are supported. The procedures for debug and trace rely on Arm Coresight technology. The salient features for debug are:

- Secure mode entry for debugger
- Up to 8 breakpoints, or 8 watchpoints

Tracing support is provided on both packages as shown below:

- QFP-176: 4-bit and 8-bit trace data shared with resources.

Table 76 provides the trace port to pin mapping in QFP-176 package.

Table 76. Trace Port to External Pin Mapping

External Pin Number (QFP-176)	External Pin Name	Trace Port
83 - TRACECTL	TRACECTL	CTL
84 - TRACECLK	TRACECLK	CLK
81 - TRACE[00]	TRACE[00]	TRACE[00]
82 - TRACE[01]	TRACE[01]	TRACE[01]
11 - TRACE[02]	TRACE[02]	TRACE[02]
12 - TRACE[03]	TRACE[03]	TRACE[03]
13 - TRACE[04]	TRACE[04]	TRACE[04]
14 - TRACE[05]	TRACE[05]	TRACE[05]
86 - TRACE[06]	TRACE[06]	TRACE[06]
87 - TRACE[07]	TRACE[07]	TRACE[07]

Package QFP-176 has no dedicated trace pins. See the Port Pin Multiplexing table (see Table 16) in Port Pin Multiplexing for relevant pins and the corresponding settings for their activation.

In general, additional information regarding debug and trace methodology can be obtained from Coresight TRM provided by Arm Limited. However, an additional characteristic is the support of security feature to prevent unauthorized access through the debug port. At the time of initiating the debugger access, it depends on the security configuration of the device, whether it is necessary to transmit a security key. The security key can only be transmitted once after reset. If a wrong key is entered, further accesses are disabled, and the only method to regain access is through application of external reset.

In the device, trace support is provided for the following components/buses:

1. Embedded Trace Macro (ETM) and Instrumentation Trace Macro (ITM) for processor core
2. Independent AHB bus trace macro (HTM) for up to 8 busses (see [Table 77](#)).

Further, Cross Trigger Interface (CTI) macros are included to support cross triggering among all the above macros.

Table 77. HTM Trace Sources

Bus	Width (Bits)	Source ID
DMA master	64	1
PERI4 master	32	2
MEMORY_CONFIG slave	64	3
MCU_CONFIG slave	32	4
PERI5 slave	32	5
PERI3 slave	64	6
PERI4 slave	32	7
HSSPI slave	32	8

Power domain on/off status information can be obtained through debug port by accessing register on memory mapped address 0xB0509400. This provides an easy method to obtain information on current state of power domains, without the need to access device level internal registers. [Table 78](#) provides the details.

Table 78. Power Domain Status Information for Debugger

Bit Number	Function
31:3	Reserved
2	PD4 on/off status 0: Power domain is off 1: Power domain is on
1	PD3 on/off status 0: Power domain is off 1: Power domain is on
0	PD2 on/off status 0: Power domain is off 1: Power domain is on

Handling Devices

Preventing Latch-up

Latch-up may occur in a CMOS IC if a voltage higher than (V_{DD} , V_{DP3} or V_{DP5}) or less than (V_{SS}) is applied to an input or output pin or if a voltage exceeding the rating is applied between the power supply pins and ground pins. If latch-up occurs, the power supply current increases rapidly, sometimes resulting in thermal breakdown of the device. Therefore, be very careful not to apply voltages in excess of the absolute maximum ratings.

Handling of Unused Input Pins

If unused input pins are left open, abnormal operation may result. Any unused input pins should be connected to pull-up or pull-down resistor ($2K\Omega$ to $10K\Omega$) or enable internal pullup or pulldown resistors (PUE/PDE) before the input enable (PIE) is activated by software. The pins of circuit type MODE can be connected to V_{SS} or V_{DP5} directly.

Power Supply Pins

In FCR4 series, devices including multiple power supply pins and ground pins are designed as follows: pins necessary to be at the same potential are interconnected internally to prevent malfunctions such as latch-up. All of the power supply pins and ground pins must be externally connected to the power supply and ground respectively in order to reduce unnecessary radiation, to prevent strobe signal malfunctions due to the ground level rising and to follow the total output current ratings. Furthermore, the power supply pins and ground pins of the FCR4 series must be connected to the current supply source via a low impedance. It is also recommended to connect a ceramic capacitor of approximately $0.1 \mu\text{F}$ as a bypass capacitor between power supply pin and ground pin near this device. If DV_{CC} is not set to the same voltage level as AV_{DD5} , the ZPD functionality of SMC pins cannot be used.

Power on Sequence

At any time, the difference between the power supply pins belonging to the same voltage level must not exceed 0.5V. This especially applies to the power on sequence. Otherwise, the risk of latchup will increase. [Figure 24](#) shows the power on sequence and the groups of power supply that might be used, depending on the actual application.

Furthermore, V_{DP5} supply must be switched on before any other power supply or at least at the same time. The following conditions must be fulfilled at any moment:

1. The voltage of V_{DP5} must be higher or equal than the voltage on AV_{DD5} and AV_{RH5} .
2. The voltage of V_{DP3} must be higher or equal than the voltage on V_{DD} . In particular, V_{DP3} must not be switched off for saving power.
3. The supply voltage for MODE and RSTX pins must reach the minimum operational value before switching on core voltage supply.

Figure 24. Power on Sequence

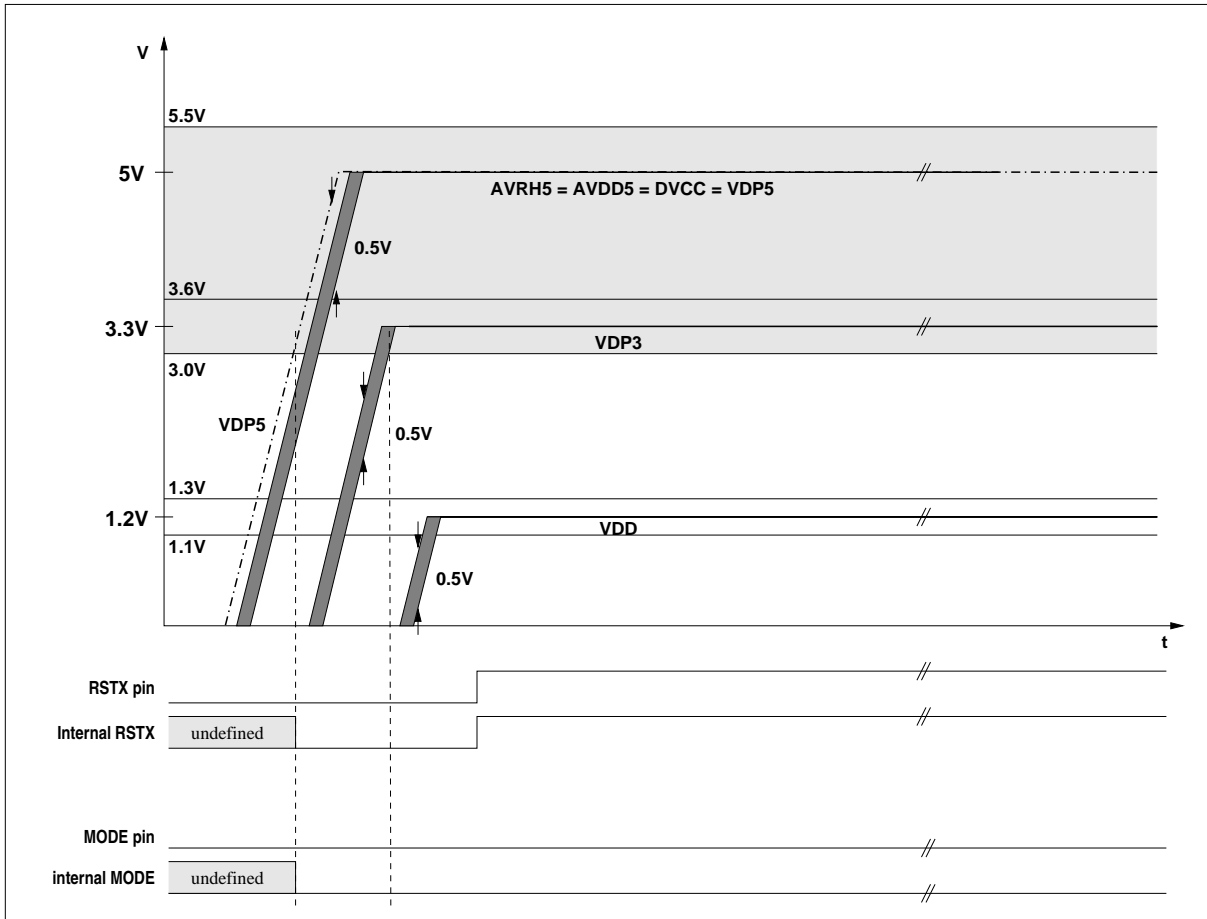

Pin State During Active External Reset

Table 79 shows the state of output/bidirectional pins during External Reset. For subsequent reset or power saving states, the pin state can be programmed according to the possibilities listed in HWM. Before software execution is started, however, the user must pay attention to the listed behavior.

Table 79. Pin State During Active External Reset

Pin Type	Reset State
JTAGO	HIZ
BIDI50	HIZ
BIDI33	HIZ
SMC	HIZ
I2C	HIZ
RSDS	HIZ
TTL33	HIZ

Crystal Oscillator Circuit

Noise in proximity to the X0/X0A and X1/X1A pins can cause the device to operate abnormally. Printed circuit boards should be designed so that the X0/X0A and X1/X1A pins, and crystal oscillator, as well as bypass capacitors connected to ground, are located near the device and ground.

It is recommended that the printed circuit board layout be designed such that the X0/X0A and X1/X1A pins are surrounded by ground plane for the stable operation.

Please request the oscillator manufacturer to evaluate the related characteristics of the crystal and this device.

Notes on Using External Clock

Opposite Phase Clock Supply: Oscillation Mode

When using the external clock, it is possible to simultaneously supply the X0/X0A and X1/X1A pins. In the described combination X0/X0A should be supplied with a clock signal which has the opposite phase to the X1/X1A pins. However, in this case the stop mode (oscillation stop mode) must not be used (This is because the X1/X1A pin stops at "H" output in STOP mode).

With opposite phase supply at X0 and X1, a frequency up to 16 MHz is possible.

Example of Using Opposite Phase Supply

Figure 25. Example of Using Opposite Phase Supply

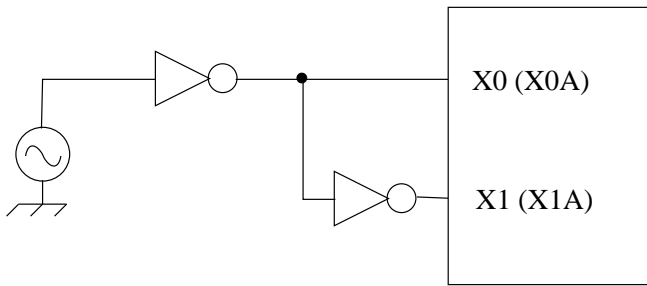

Single Phase Clock Supply

For lower frequencies, up to 4 MHz, it is possible to supply a single phase clock at X0.

Figure 26. Example of Using Single Phase Supply

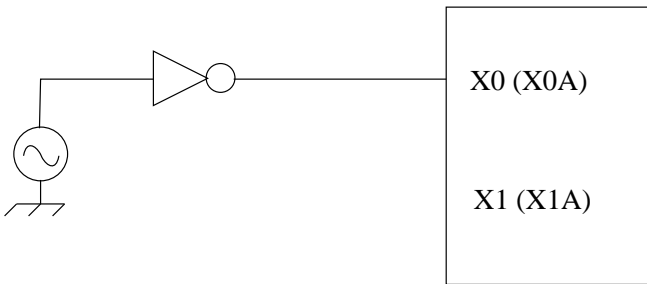

Single Phase Clock Supply: Fast Clock Input Mode

When a high frequency clock needs to be fed, it is possible to directly supply a single phase clock at X0. For this mode:

- SYSC_SPCCFGR:FCIMEN bit must be set to "1".
- The input clock must have 50% duty cycle.

Example of Using Fast Clock Input Mode

Figure 27. Example of Using Fast Clock Input Mode

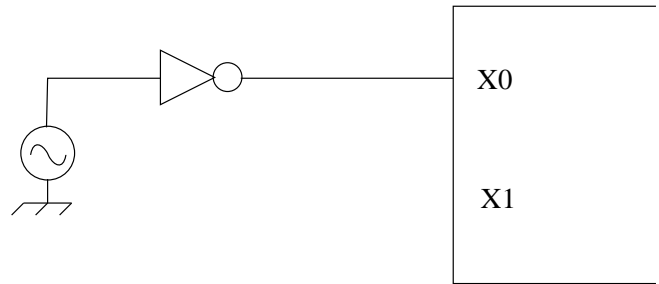

Unused Sub Clock Signal

If the pins X0A and X1A are not connected to an oscillator, a pull-down resistor must be connected on the X0A pin and the X1A pin must be left open.

Reference Documents

Document Type	Definition	Primary User	Document Code
CY9EF226 Datasheet	The function and its characteristics are specified quantitatively.	Investigator and hardware engineer	002-05678
FCR4 Cluster Hardware manual	The function and its operation of FCR4 cluster series are described.	Software engineer	002-09388
Iris-SDL Hardware manual	The function and its operation of GPU core platform are described.	Software engineer	002-09380
Arm® Cortex™-R4 Technical Reference Manual	Arm documentation set for the Arm Cortex-R4 processor core platform	Software engineer	Revision: r1p4
Application note	The reference software, sample application, the reference board design and so on are explained.	Software and hardware engineer	Under consideration

Notes

- 42. Refer all documents for the system development.
- 43. Primary user is a most likely engineer for whom the document is the most useful.
- 44. FCR4 Hardware manual is expected to be used as dictionary of platform specification.
- 45. The IRIS-SDL manual describes the implemented graphics IP.
- 46. The Arm Technical Reference manual describes the Cortex™-R4 architecture of core, bus, trace and debug interface.

Errata

This section describes the errata for the Titan, CY9EF226. Details include errata trigger conditions, scope of impact, available workaround, and silicon revision applicability. Contact your local Cypress Sales Representative if you have questions.

CY9EF226 Qualification Status

In Production

CY9EF226 Errata Summary

The following table defines the errata applicability to the affected part numbers of Titan, CY9EF226.

Items	Affected Part Number	Fix Status
[1] Flash Erase Suspend Issue	CY9EF226BPMC-GSE2 CY9EF226EBPMC-GSE2 CY9EF226LBPMC-GSE2	No silicon fix planned. Workaround available.
[2] Port Pin Output Function Select Problem		
[3] SHE AXI Master Address Mask Problem		
[4] TCFlash Programming		
[5] 3V IO Doman ESD Diode		
[6] IRQ Unit Register Read Timing Issue		
[7] IUNIT Interrupt Handling Problem		
[8] IUNIT Nesting Level Status Problem		
[9] 1.2V LVD VDP3 Supply Problem		
[10] SCT Compare Value Update Limitation		
[11] Flash Execution Limitation		No silicon fix planned. No workaround available.
[12] Automatic ADC Input Disable Problem		No silicon fix planned. No workaround available.
[13] RTC Configuration Synchronization Problem		No silicon fix planned. Workaround available.
[14] PSS Wakeup Problem		
[15] Undefined Data under Certain Conditions when Reading the Flash Memory		

1. Flash Erase Suspend Issue																													
Problem Definition	The functional limitation was found with Flash memory implemented in the Arm Cortex R4 cluster series MCUs. After issuing a Flash memory erase suspend command during Flash memory erase operation data of Flash memory may not be correctly readable even when the erase suspend state is reached. This functional limitation can only occur when erase suspend is used.																												
Parameters Affected	All part numbers of the CY9EF226 series are affected.																												
Conditions for Functional Limitation	The limitation may occur when all following conditions are met: <ul style="list-style-type: none"> ■ The sector erase suspend command is issued during sector erase. ■ When a read command is issued to one of the sectors inside the Flash macro currently in sector erase suspend state. 																												
Details of the Limitation	Data may not be read correctly irrespective of the large sectors or small sectors if the following operations are executed in sequence: <ul style="list-style-type: none"> ■ The sector erase suspend command is issued to the flash memory during sector erase. ■ After the state of the sector erase suspend is completed, the reading operation for the flash memory (instruction read or data read) is performed. <p>In this case, the read data are undefined. After this, read data will remain undefined until the sector erase resume command is issued. Combination of operating conditions for flash memories is the following table.</p> <p>Table 95. Combination of Operating Conditions for Flash Memories (FCR4 Family)</p> <table border="1"> <thead> <tr> <th></th> <th>Flash Memory to which the Sector Erase Suspend Command is Issued</th> <th>Flash Memory from which Data is Read</th> <th>Read Value of Data in the Sector Erase Suspend State</th> </tr> </thead> <tbody> <tr> <td>1</td> <td>TC Flash-A</td> <td>TC Flash-A</td> <td>Undefined</td> </tr> <tr> <td>2</td> <td>TC Flash-B</td> <td>TC Flash-B</td> <td>Undefined</td> </tr> <tr> <td>3</td> <td>EE Flash</td> <td>EE Flash</td> <td>Undefined</td> </tr> <tr> <td>4</td> <td>TC Flash-A</td> <td>TC Flash-B / EE Flash</td> <td>Normal</td> </tr> <tr> <td>5</td> <td>TC Flash-B</td> <td>TC Flash-A / EE</td> <td>Normal</td> </tr> <tr> <td>6</td> <td>EE Flash</td> <td>TC Flash-A / TC Flash-B</td> <td>Normal</td> </tr> </tbody> </table>		Flash Memory to which the Sector Erase Suspend Command is Issued	Flash Memory from which Data is Read	Read Value of Data in the Sector Erase Suspend State	1	TC Flash-A	TC Flash-A	Undefined	2	TC Flash-B	TC Flash-B	Undefined	3	EE Flash	EE Flash	Undefined	4	TC Flash-A	TC Flash-B / EE Flash	Normal	5	TC Flash-B	TC Flash-A / EE	Normal	6	EE Flash	TC Flash-A / TC Flash-B	Normal
	Flash Memory to which the Sector Erase Suspend Command is Issued	Flash Memory from which Data is Read	Read Value of Data in the Sector Erase Suspend State																										
1	TC Flash-A	TC Flash-A	Undefined																										
2	TC Flash-B	TC Flash-B	Undefined																										
3	EE Flash	EE Flash	Undefined																										
4	TC Flash-A	TC Flash-B / EE Flash	Normal																										
5	TC Flash-B	TC Flash-A / EE	Normal																										
6	EE Flash	TC Flash-A / TC Flash-B	Normal																										
Causes of the Limitation	The flash memory control circuit consists of the following two circuits: <ul style="list-style-type: none"> ■ The circuit to control automatic algorithm execution for sector erase operation. ■ The circuit, which receives the sector erase suspend command from the above mentioned circuit, to stop the automatic algorithm execution and to switch to the state where the read operation is enabled. <p>The limitation is caused by the circuitry changing the erase state to erase suspend state not allowing normal data read.</p>																												
Workaround	Refer to Workaround for Flash Erase Suspend Issue on page 310 .																												
Fix Status	There is no plan to fix this limitation. SW workaround is available. The following software products (all releases) are not affected by this limitation, because they do not use erase suspend: <ul style="list-style-type: none"> ■ FCR4 MCAL (SW-MCAL31-DRV-FCR4-E01, SW-MCAL31-DRV-FCR4-E02, SW-MCAL40-DRV-FCR4-E01) ■ FCR4 FEE/FLS (SW-FEEFLS-DRV-FCR4-E01, SW-FEE40-DRV-FCR4-E01) 																												

2. Port Pin Output Function Select Problem	
Problem Definition	A problem was found in the logic of the port pin multiplexing on 32-bit FCR4 Cluster Series MCUs. Because of this problem the behaviour of the port pin multiplexing is not working as specified. This problem is called "Port Pin Output Function Select Problem".
Parameters Affected	All part numbers of the CY9EF226 series are affected.
Trigger Condition	The problem occurs if the port pin output function select value '010' is programmed for port pin P2_40, P2_41, P2_42 or P2_43.
Rootcause	The port pin output function select value '010' for port pin P2_40, P2_41, P2_42, P2_43 does not select the specified output function.
Workaround	Do not program pin output function select value '010' for port pin P2_40, P2_41, P2_42, P2_43. To use the resources specified for port pin output function, select value '010' on port pin P2_40, P2_41, P2_42, P2_43. Select another specified port pin location for the corresponding resource functional output. Note The pin output function RTC_WOT, SYSC_CKOT, SYSC_CKOTX, WDG_OBSERVE specified on port pin P0_40, P0_41, P0_42, P0_43 are only supported when power domain PD2 is active.
Fix Status	No fixes planned. SW workaround is available.

3. SHE AXI Master Address Mask Problem	
Problem Definition	<p>The SHE AXI Master Address Mask problem was found in the AXI Master Interface on the 32-bit FCR4 Cluster Series MCUs.</p> <p>In case Input Channel Master is configured in a way the transfer will start in the address ranges:</p> <ul style="list-style-type: none"> ■ 0x05900000 - 0x059FFFFFF ■ 0x05FE0000 - 0x05FEFFFF <p>the first burst will be executed starting at the configured address. The transfer will continue after the completion of the first burst at address 0x00FF0000.</p> <p>In case Input Channel Master is configured in a way the transfer will start in either of the address ranges:</p> <ul style="list-style-type: none"> ■ 0x01100000 - 0x011FFFFFF ■ 0x017E0000 - 0x017EFFFF <p>the first burst will be executed starting at the configured address. The transfer will continue after the completion of the first burst at address 0x017F0000.</p> <p>In case Input Channel Master is configured in a way the transfer will start outside of both the address ranges</p> <ul style="list-style-type: none"> ■ 0x05900000 - 0x059FFFFFF ■ 0x05FE0000 - 0x05FEFFFF <p>But crossing these address ranges, the transfer will be performed till address 0x058FFFFFF and continue with next burst at address 0x05FF0000.</p> <p>In case Input Channel Master is configured in a way the transfer will start outside the address ranges</p> <ul style="list-style-type: none"> ■ 0x01100000 - 0x011FFFFFF ■ 0x017E0000 - 0x017EFFFF <p>but crossing these address ranges, the transfer will be performed till address 0x010FFFFFF and continue with next burst at address 0x017F0000.</p>
Parameters Affected	All part numbers of the CY9EF226 series are affected.

3. SHE AXI Master Address Mask Problem (Continued)	
Trigger Conditions	<p>Problem may occur if all of the following conditions are met:</p> <ul style="list-style-type: none"> ■ Secure boot for TCFlash or any SHE AXI Master read operation is used. Note Secure boot uses SHE AXI Master implicitly. ■ Above operation includes access to any of the following address ranges: <ul style="list-style-type: none"> <input type="checkbox"/> 0x05900000 - 0x059FFFFFF <input type="checkbox"/> 0x05FE0000 - 0x05FEFFFFFF <input type="checkbox"/> 0x01100000 - 0x011FFFFFF <input type="checkbox"/> 0x017E0000 - 0x017EFFFF
Rootcause	The current implementation of the SHE AXI Interface masks the address range between large and small sectors. The size of the masking window overlaps with Flash address range 0x05900000 - 0x059FFFFFF, 0x05FE0000 - 0x05FEFFFFFF, 0x01100000 - 0x011FFFFFF and 0x017E0000 - 0x017EFFFF.
Workaround	<ul style="list-style-type: none"> ■ Store code protected by Secure Boot either in address range <ul style="list-style-type: none"> <input type="checkbox"/> 0x01000000 - 0x010FFFFFF (0x05800000 - 0x058FFFFFF), or <input type="checkbox"/> 0x017F0000 - 0x017FFFFFF (0x05FF0000 - 0x05FFFFFF) ■ Do not access the following address ranges via SHE AXI Master IF (relocate content or use SHE Input FIFO instead) <ul style="list-style-type: none"> <input type="checkbox"/> 0x05900000 - 0x059FFFFFF <input type="checkbox"/> 0x05FE0000 - 0x05FEFFFFFF <input type="checkbox"/> 0x01000000 - 0x010FFFFFF <input type="checkbox"/> 0x017F0000 - 0x017FFFFFF
Fix Status	No fixes planned. SW workaround is available.

4. TCFlash Programming	
Problem Definition	TCFlash programming problem was found in the logic of the TCFlash Interface in the CY9EF226 series. Because of this problem, the behavior of the TCFlash programming is not working as specified.
Parameters Affected	All part numbers of the CY9EF226 series are affected.
Trigger Conditions	Programming the TCFlash with ECC is not possible with 16 bit access sequences.
Rootcause	Data abort of 16 bit programming sequence.
Workaround	To handle ECC calculation and Flash writes, Flash write in CPU mode is restricted to 32-bit mode.
Fix Status	No fixes planned. SW workaround is available.

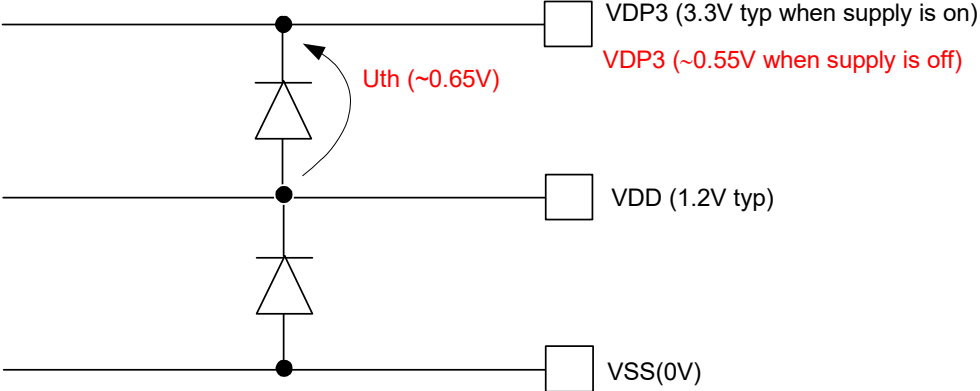
5. 3V IO Doman ESD Diode	
Problem Definition	<p>The 3V IO domain ESD diode problem was found in the specific use-case of switching off the VDP3 supply (3V IO domain) on 32-bit FCR4 Cluster Series MCUs.</p> <p>Due to an ESD diode between VDD (core supply) and VDP3 (3V IO domain supply), the voltage on VDP3 does not reach 0V even if not supplied.</p> <p>External components connected to same supply as VDP3 will be supplied with a voltage around 0.55V from VDD supply. Therefore, power saving target in standby modes may not be achieved.</p>
Parameters Affected	All part numbers of the CY9EF226 series are affected.
Trigger Conditions	The problem occurs if the supply of the 3V IO domain (VDP3) is switched off.
Rootcause	<p>There is an ESD diode between VDD and VDP3 in the core supply cell to protect VDD against ESD overvoltage.</p>  <p>In case VDP3 supply is switched off, then VDP3 is supplied by VDD - Uth (threshold voltage of diode) which is around $1.2V - 0.65V = 0.55V$.</p>
Workaround	<p>Choose any one of the following workaround:</p> <ol style="list-style-type: none"> 1. Keep 3V power on in standby modes, or 2. Switch 3V power off in standby modes, and use separated supplies of MCU and external components to avoid external components being supplied via ESD diode, or 3. Switch 3V power off in standby modes, and use same supply of MCU and external components, but do not exceed the maximum current limit of forward-biased diode which is 4mA, i.e. current on VDP3 must not exceed 4mA in that case.
Fix Status	No fixes planned. Hardware workaround is available.

6. IRQ Unit Register Read Timing Issue	
Problem Definition	<p>The IRQ Unit register read timing issue was found in the Interrupt Unit (i.e., IRQ-Unit or I-Unit) on the 32-bit FCR4 Cluster Series MCUs. Due to this problem, data from I-Unit registers may be invalid when read at CLK_MEM_I_PD3 frequencies higher than 64 MHz (even though CLK_MEM_I_PD3 maximum frequency is specified up to 128 MHz).</p> <p>The following are not affected by the timing issue:</p> <ul style="list-style-type: none"> ■ Write accesses to Interrupt Unit ■ IRQ vector address transfer to CPU via Arm VIC port (if enabled)
Parameters Affected	All part numbers of the CY9EF226 series are affected.
Trigger Conditions	<p>The problem may occur at the following conditions:</p> <ul style="list-style-type: none"> ■ CLK_MEM_I_PD3 is set to more than 64 MHz, and ■ Data is read from I-Unit addresses (0xB0400000 - 0xB0400D57) or IRQ0_NMIVAS mirror register at address 0xFFFEFBFC <p>Since occurrence of this timing issue is depending on logic path delays, the probability of reading invalid data is increasing with:</p> <ul style="list-style-type: none"> ■ Higher temperature conditions than room temperature ■ Lower voltage conditions on VDD supply than nominal 1.2V ■ Wafer process slow conditions
Rootcause	<p>The root cause for this problem is a misinterpretation of the internal specification document, which states that one wait cycle is inserted in AHB read transactions while reading of all registers of the interrupt controller module. In the RTL design, there is one additional wait cycle added on the AHB bus, but internally, there was just one pipeline register added to the register read paths. With this, the valid read data is captured after one clock cycle, and then simply delayed by another clock cycle. For creating the timing constraining of the interrupt controller module, it was incorrectly assumed that the register read data actually has two clock cycles 'time' until it is being captured (and then output to the AHB bus). This assumption then led to the incorrect introduction of a multicycle_path definition in the timing constraints file, which effectively causes a frequency relaxation of a factor of 2 for all register read accesses to interrupt controller registers.</p>
Workaround	For workaround details, refer to “Workaround for IRQ Unit Register Read Timing Issue” on page 311.
Fix Status	No fixes planned. SW workaround is available.

7. IUNIT Interrupt Handling Problem	
Problem Definition	<p>The IUNIT Interrupt Handling problem was found in the logic of the IUNIT on 32-bit FCR4 Cluster Series MCUs. Because of this problem, the IUNIT is not working as specified.</p> <ul style="list-style-type: none"> ■ IRQ Priority Level Mask: If enabled IRQ[n] is selected by the priority encoder (no other interrupt with higher priority pending and $IRQ0_IRQPLn < IRQ0_IRQPLM$) and $IRQ0_IRQPLM$ is changed to $IRQ0_IRQPLM \leq IRQ0_IRQPLn$ while the interrupt unit is waiting for the CPU to read the interrupt vector address, the interrupt hold status for IRQ[n] in $IRQ0_IRQHSn$ is not set. <ul style="list-style-type: none"> □ If IRQ[n] is active and $IRQ0_IRQPLM$ is set to $IRQ0_IRQPLM > IRQ0_IRQPL[n]$ before the interrupt flag at the peripheral is cleared and no enabled interrupt with high priority was asserted then IRQ[n] will be selected again for interrupt service. □ If IRQ[n]/IRQ[m] is active and $IRQ0_IRQPLM$ is set to $IRQ0_IRQPLM > IRQ0_IRQPL[m] > IRQ0_IRQPL[n]$ after the interrupt flag at the peripheral asserting IRQ[n] is cleared and no enabled interrupt with higher priority was asserted, then IRQ[n] will be nested by IRQ[m]. ■ IRQ/NMI Priority Level: $IRQ0_IRQPL0\sim127$, $IRQ0_NMIPL0\sim7$ are changed during interrupt priority evaluation. <ul style="list-style-type: none"> □ Wrong IRQ/NMI interrupt number and vector (even the number and vector of a non-existing IRQ/NMI interrupt) can be handed over to the CPU. □ One IRQ/NMI interrupt is executed, but the hold status bit of another IRQ/NMI interrupt (or no hold status bit or several hold status bits) may get set. ■ IRQ/NMI Hold clear: $IRQ0_IRQHC$, $IRQ0_NMIHC$ are written during interrupt priority evaluation. <ul style="list-style-type: none"> □ Wrong IRQ/NMI interrupt number and vector (even the number and vector of a non-existing IRQ/NMI interrupt) can be handed over to the CPU. ■ IRQ0_IRQHC byte write access: 8-bit (byte) width write access to $IRQ0_IRQHC$ register triggers the hold clear of partly specified IRQ number.
Parameters Affected	All part numbers of the CY9EF226 series are affected.
Trigger Condition	<ol style="list-style-type: none"> 1. Enabled IRQ[n] is selected for interrupt service (no other interrupt with higher priority pending and $IRQ0_IRQPLn < IRQPLM$) and $IRQ0_IRQPLM$ is changed to equal or lower value than $IRQ0_IRQPLn$ before $IRQ0_IRQHS$ is set (point in time when CPU reads the interrupt vector address). 2. Priorities of active IRQ/NMI are changed during interrupt priority evaluation. 3. IRQ/NMI Hold Bit is cleared during interrupt priority evaluation. 4. $IRQ0_IRQHC$ write access with 8-bit access width.
Rootcause	<ol style="list-style-type: none"> 1. Not all inputs of priority encoder are latched during interrupt processing (period from start of priority evaluation until handover to CPU), in this case priority level mask $IRQ0_IRQPLM$. 2. Not all inputs of priority encoder are latched during interrupt processing (period from start of priority evaluation until handover to CPU), in this case priority level $IRQ0_IRQPL0\sim127$, resp. $IRQ0_NMIPL0\sim7$. 3. Not all inputs of priority encoder are latched during interrupt processing (period from start of priority evaluation until handover to CPU), in this case hold status $IRQ0_IRQHS0\sim15$ cleared by $IRQ0_IRQHC$, resp. $IRQ0_NMIHS$ cleared by $IRQ0_NMIHC$. 4. Write strobes for the relevant 2 bytes of $IRQ0_IRQHC$ are evaluated by OR instead of AND which causes byte write access effects change on full 16 Bit.
Workaround	Refer to Workaround for IUNIT Interrupt Handling Problem on page 318 .
Fix Status	No fixes planned. SW workaround is available.

8. IUNIT Nesting Level Status Problem	
Problem Definition	The IUNIT Nesting Level Status Register problem was found in the logic of IUNIT on the 32-bit FCR4 Cluster Series MCUs. Because of this problem, the IUNIT Nesting Level Status Register (IRQ0_NESTL) is not working as specified.
Parameters Affected	All part numbers of the CY9EF226 series are affected.
Trigger Conditions	At least one of the following conditions must occur: <ul style="list-style-type: none"> ■ Handover of IRQ vector address to CPU (by VIC protocol) and clearing of IRQ Hold status (by CPU executing ISR) occurs in the same clock cycle ■ Handover of NMI vector address to CPU (by CPU reading the IRQ0_NMIVAS register) occurs one clock cycle before clearing of NMI Hold status (by CPU executing NMI handler).
Rootcause	<p>IRQ0_NESTL:IRQNL:</p> <p>If handover of IRQ vector address to CPU (by VIC protocol) and clearing of IRQ Hold status (by CPU executing ISR) occurs in the same clock cycle, then IRQ0_NESTL:IRQNL is incremented (if it is =0) or decremented (if it is !=0), but its value should not be changed.</p> <p>IRQ0_NESTL:NMINL:</p> <p>If handover of NMI vector address to CPU (by CPU reading the IRQ0_NMIVAS register) occurs one clock cycle before clearing of NMI Hold status (by CPU executing NMI handler), then IRQ0_NESTL:NMINL is incremented (if it is =0) or decremented (if it is !=0), but its value should not be changed.</p>
Workaround	Do not evaluate the value returned by reading IUNIT Nesting Level Status Register (IRQ0_NESTL). If software needs information about the current nesting level, a variable counter can be implemented which is incremented/decremented in the interrupt handler entry/exit code.
Fix Status	No fixes planned. SW workaround is available.

9. 1.2V LVD VDP3 Supply Problem	
Problem Definition	<p>The 1.2V Low Voltage Detection – VDP3 Supply problem was found on 32-bit FCR4 Cluster Series MCUs in the behavior of the 1.2V Low Voltage Detection (1.2V LVD, which is supervising the 1.2V core supply VDD) which is linked to the VDP3 supply voltage.</p> <p>Because of this problem, the 1.2V LVD may not output power-good even if VDD supply is above set limit of LVD.</p> <p>This may cause prevention of system startup after power-on and reset release and/or wrong 1.2V LVD behavior (Reset/Interrupt) at RUN and PSS mode.</p>
Parameters Affected	All part numbers of the CY9EF226 series are affected.
Trigger Conditions	<p>The problem may occur at the following conditions:</p> <ul style="list-style-type: none"> ■ VDD is above set limits of 1.2V LVD (set by default to 0.8V lower limit at reset) ■ 1.2V LVD is enabled (enabled by default at reset) ■ VDP3 supply is smaller than 2.2V
Rootcause	<p>The band-gap reference (BGR) of 1.2V LVD (supervising 1.2V core supply VDD) is connected to VDP3 supply.</p> <p>If VDP3 supply is <2.2V, then 1.2V LVD may not output power-good even if VDD supply is above set limit of LVD.</p>
Workaround	<p>Keep VDP3 supply $\geq 2.2V$ for correct operation of 1.2V LVD (at device startup and in RUN/PSS modes). If 1.2V LVD is disabled at:</p> <ul style="list-style-type: none"> ■ RUN mode SYSC_RUNLVDCFGR.LVDE12 := 0, and ■ PSS mode: SYSC_PSSLVDCFGR.LVDE12 := 0, <p>then VDP3 can be lower than 2.2V, but consider behavior as described in 3V IO Doman ESD Diode on page 296.</p>
Fix Status	No fixes planned. SW workaround is available.

10. SCT Compare Value Update Limitation	
Problem Definition	<p>The SCT compare value update limitation problem was found in the Slow RC, RC, Main and Sub Source Clock Timer on 32-bit FCR4 Cluster Series MCUs.</p> <p>In case a new compare value SYSC_SRCSTCPR_CMPR is captured triggered by writing '1' to SYSC_SRCSTTRG_CGCPT it could happen that the Slow RC Source Clock Timer Counter is set to an arbitrary value.</p> <p>In case a new compare value SYSC_RCSTCPR_CMPR is captured triggered by writing '1' to SYSC_RCSTTRG_CGCPT it could happen that the RC Source Clock Timer Counter is set to an arbitrary value.</p> <p>In case a new compare value SYSC_MAINSTCPR_CMPR is captured triggered by writing '1' to SYSC_MAINSTTRG_CGCPT it could happen that the Main Source Clock Timer Counter is set to an arbitrary value.</p> <p>In case a new compare value SYSC_SUBSTCPR_CMPR is captured triggered by writing '1' to SYSC_SUBSTTRG_CGCPT it could happen that the Sub Source Clock Timer Counter is set to an arbitrary value.</p>
Parameters Affected	All part numbers of the CY9EF226 series are affected.
Trigger Conditions	<p>Problem may occur for Slow RC Source Clock Timer if all of the following conditions are met:</p> <ul style="list-style-type: none"> ■ SRC source clock timer runs with compare value "old value" ■ SYSC_SRCSTCPR_CMPR is set to "new value" ■ SYSC_SRCSTTRG_CGCPT set to '1' trigger compare value update ■ Bitwise AND of "new value" and "old value" is equal to 0 and neither "new value" nor "old value" equal to 0. By hard reset "old value" is initialized to 0x0001. <p>Problem may occur for RC Source Clock Timer if all of the following conditions are met:</p> <ul style="list-style-type: none"> ■ RC Source Clock Timer runs with compare value "old value" ■ SYSC_RCSTCPR_CMPR is set to "new value" ■ SYSC_RCSTTRG_CGCPT set to '1' trigger compare value update ■ Bitwise AND of "new value" and "old value" is equal to 0 and neither "new value" nor "old value" equal to 0. By hard reset "old value" is initialized to 0x001E. <p>Problem may occur for Main Source Clock Timer if all of the following conditions are met:</p> <ul style="list-style-type: none"> ■ Main Source Clock Timer runs with compare value "old value" ■ SYSC_MAINSTCPR_CMPR is set to "new value" ■ SYSC_MAINSTTRG_CGCPT set to '1' trigger compare value update ■ Bitwise AND of "new value" and "old value" is equal to 0 and neither "new value" nor "old value" equal to 0. By hard reset "old value" is initialized to 0x1000. <p>Problem may occur for Sub Source Clock Timer if all of the following conditions are met:</p> <ul style="list-style-type: none"> ■ Sub Source Clock Timer runs with compare value "old value" ■ SYSC_SUBSTCPR_CMPR is set to "new value" ■ SYSC_SUBSTTRG_CGCPT set to '1' trigger compare value update ■ Bitwise AND of "new value" and "old value" is equal to 0 and neither "new value" nor "old value" equal to 0. By hard reset "old value" is initialized to 0x0400.
Rootcause	The current implementation of the Source Clock Timer generates an asynchronous reset for the Source Clock Timer Counter in case the updated compare value is 0. This condition could be met for a short period of time when the compare value register in the Source Clock Timer captures the new compare value and generates a glitch at the reset of the counter registers. The width of this glitch does not guarantee a valid reset. As a result of this glitch, it is unpredictable which of the counter register bits is reset and which is not.
Workaround	For changing the compare value of a Source Clock timer from effective "old value" to a "new value", ensure the following conditions is true: "old value" & "new value" != 0
Fix Status	No fixes planned. SW workaround is available.

11. Flash Execution Limitation	
Problem Definition	The Flash Code Execution Limitation problem was found on 32-bit FCR4 Cluster Series MCUs. In case device is secured and code execution is done from following address areas in TCFlash: SA0/SA1: 0x00FF0000 - 0x00FF3FFF (TCM)/ 0x017F0000 - 0x017F3FFF (AXI), a pre-fetch abort exception occurs.
Parameters Affected	All part numbers of the CY series are affected.
Trigger Conditions	The problem occurs when device is secured and a code fetch is done from following addresses in TC Flash 0x00FF0000 - 0x00FF3FFF (TCM)/ 0x017F0000 - 0x017F3FFF (AXI)
Rootcause	The current implementation of the flash security for protecting code execution from address space reserved for Main SDR and TCFlash SDR uses for comparison of the access area the CPU address translated into flash address. As limits there are used the lowest and highest CPU address without reflecting the interleaved arrangement of the flash sectors. So data access for code fetch within in the address range FA=0x0000 to 0x20DF for TCFlash A and range FA=0x0000 to 0x209F for TCFlash B is rejected and leads to pre-fetch abort exception. Code fetch is done 64-Bit aligned therefore always a Flash address from sector 0 is used for comparison. Due to the interleaved arrangement of sector 0, sector 1 in the CPU address space this prevents to use sector 1 for code execution too.

Interleaved arrangement of Flash sectors in CPU Address Map

Sequential arrangement of the sectors in the flash

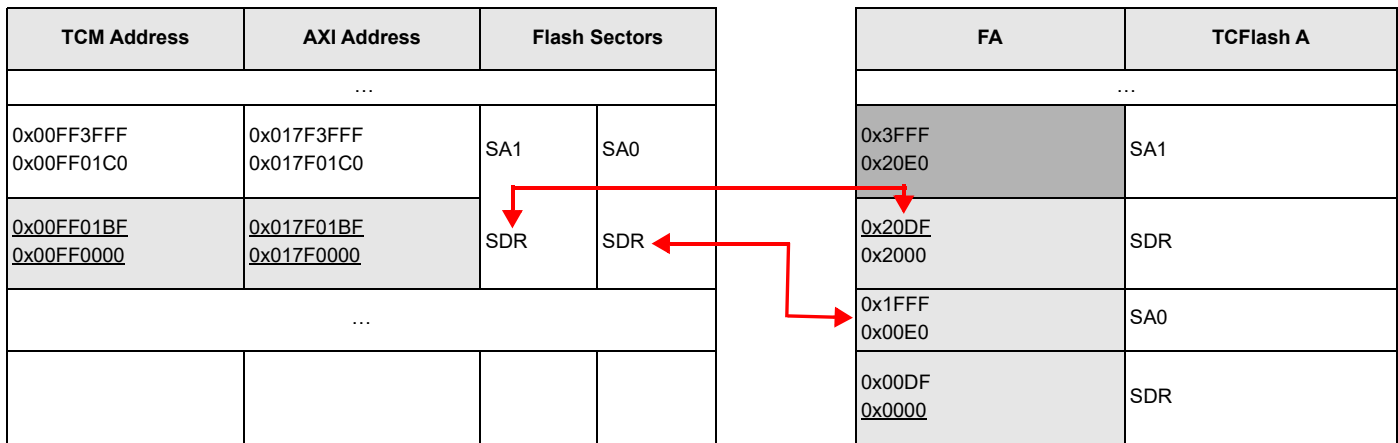

Rootcause (Cont.)	Example TCFlash macro A: 0x017F0000 - 0x017F01BF (AXI) shall be non-executable if device is secured. The address comparison is done after translation to sequential flash addresses: 0x017F0000 --> 0x0000 0x017F01BF --> 0x20DF Any code fetch (after translation) from flash address 0x0000 - 0x20DF will be prohibited, which effectively covers 0x0000 - 0x3FFF area since code fetches are always done with 64-bit width. A correct implementation would need to compare the access with two areas: 0x0000 - 0x00DF and 0x2000 - 0x20DF
Workaround	None, but read accesses are not prohibited, hence the affected regions can be used for constants.
Fix Status	No fixes planned.

12. Automatic ADC Input Disable Problem	
Problem Definition	<p>The Automatic ADC Input Disable problem was found in port pin multiplexing on 32-bit FCR4 Cluster Series MCUs.</p> <p>Intended function: For pins with an ADC input, the digital input buffer is disabled irrespective of the PPC_PCFGRIj:PIE value if the corresponding ADC channel is enabled, i.e., if the corresponding bit of the ADCn_ER32/ADCn_ER10 register is set to '1'.</p> <p>Problem:</p> <p>On MBEF226 series:</p> <p>Using ADC input of pin P0_40 de-activates the digital inputs of pin P0_15 and P0_40.</p> <p>Using ADC input of pin P2_41 de-activates the digital inputs of pin P0_08 and P2_41.</p> <p>Using ADC input of pin P2_42 de-activates the digital inputs of pin P0_09 and P2_42.</p> <p>Using ADC input of pin P2_43 de-activates the digital inputs of pin P0_10 and P2_43.</p> <p>Using ADC input of pin P2_44 de-activates the digital inputs of pin P0_11 and P2_44.</p> <p>Using ADC input of pin P2_45 de-activates the digital inputs of pin P0_12 and P2_45.</p> <p>Using ADC input of pin P2_46 de-activates the digital inputs of pin P0_13 and P2_46.</p> <p>Using ADC input of pin P2_47 de-activates the digital inputs of pin P0_14 and P2_47.</p>
Parameters Affected	All part numbers of the CY9EF226 series are affected.
Trigger Condition	<p>The problem occurs if the following conditions are met</p> <p>On MBEF226 series:</p> <ul style="list-style-type: none"> ■ Pin P0_40 is used as ADC input function (configuring the corresponding pin as ADC input with setting ADC0_ER32.ADE15 to '1') and ■ Pin P0_15 is used as GPIO INPUT function or Peripheral INPUT function or ■ Pin P2_41 is used as ADC input function (configuring the corresponding pin as ADC input with setting ADC0_ER32.ADE08 to '1') and ■ Pin P0_08 is used as GPIO INPUT function or Peripheral INPUT function or ■ Pin P2_42 is used as ADC input function (configuring the corresponding pin as ADC input with setting ADC0_ER32.ADE09 to '1') and ■ Pin P0_09 is used as GPIO INPUT function or Peripheral INPUT function or ■ Pin P2_43 is used as ADC input function (configuring the corresponding pin as ADC input with setting ADC0_ER32.ADE10 to '1') and ■ Pin P0_10 is used as GPIO INPUT function or Peripheral INPUT function or ■ Pin P2_44 is used as ADC input function (configuring the corresponding pin as ADC input with setting ADC0_ER32.ADE11 to '1') and ■ Pin P0_11 is used as GPIO INPUT function or Peripheral INPUT function or ■ Pin P2_45 is used as ADC input function (configuring the corresponding pin as ADC input with setting ADC0_ER32.ADE12 to '1') and ■ Pin P0_12 is used as GPIO INPUT function or Peripheral INPUT function or ■ Pin P2_46 is used as ADC input function (configuring the corresponding pin as ADC input with setting ADC0_ER32.ADE13 to '1') and ■ Pin P0_13 is used as GPIO INPUT function or Peripheral INPUT function or ■ Pin P2_47 is used as ADC input function (configuring the corresponding pin as ADC input with setting ADC0_ER32.ADE14 to '1') and ■ Pin P0_14 is used as GPIO INPUT function or Peripheral INPUT function

13. RTC Configuration Synchronization Problem (Continued)

Figure 29. Handshake Synchronization

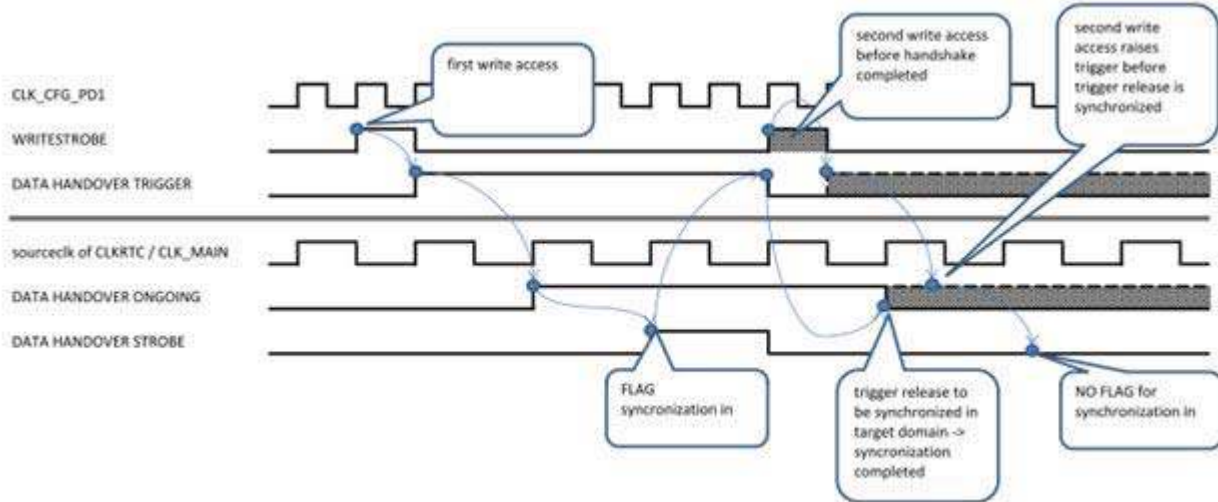

Workaround

- Ensure that after write accesses to RTC_WTCR there is no write to RTC_WTCR for 10 times the period of slowest clock out of CLK_MAIN, previous and new CLK_S_RTC and CLK_CFG_PD1.
 1. Write RTC_WTCR
 2. Read RTC_WTCR to ensure that first write has arrived at RTC due to CPU store buffer.
 3. Wait 10 times the period of slowest clock out of CLK_MAIN, previous and new CLK_S_RTC and CLK_CFG_PD1 before next write access to RTC_WTCR.

Fix Status

No fixes planned. SW workaround is available.

14. PSS Wakeup Problem	
Problem Definition	<p>The PSS Wakeup problem was found at wakeup from Power Saving State (PSS) on 32-bit FCR4 Cluster Series MCUs.</p> <p>At wakeup from PSS, an unexpected Non-Maskable Interrupt (NMI) will appear if the PSS profile settings meet certain conditions.</p>
Parameters Affected	All part numbers of the CY9EF226 series are affected.
Problem Condition	<p>The problem will occur if the following conditions are met:</p> <p>The device is in PSS state and receives a wakeup event AND the RC oscillator is OFF in PSS state (<code>SYSC_PSSCKSRER:RCOSCEN=0</code>) AND the Low Voltage Detection (LVD) threshold settings differ between RUN and PSS profile</p> <pre>((SYSC_RUNLVDCFGR:SV12[2:0] != SYSC_PSSLVDCFGR:SV12[2:0]) OR (SYSC_RUNLVDCFGR:SV33[2:0] != SYSC_PSSLVDCFGR:SV33[2:0]) OR (SYSC_RUNLVDCFGR:SV50[2:0] != SYSC_PSSLVDCFGR:SV50[2:0]))</pre>
Rootcause	<p>Before the transition from RUN to PSS state, the PSS profile is checked for validity. If the PSS profile is not valid, <code>SYSC_SYSSTSR:IPPAPSS</code> would be set and a transition to PSS would not be possible.</p> <p>When the profile was good and the device has entered the PSS state, following happens after a wakeup event:</p> <ol style="list-style-type: none"> 1. The fast RC oscillator is started (in case it was OFF in PSS). 2. An unintended PSS profile check is executed, caused by a logic bug. 3. The RUN profile is checked normally as described in hardware manual.

Figure 28. PSS to RUN State Switching

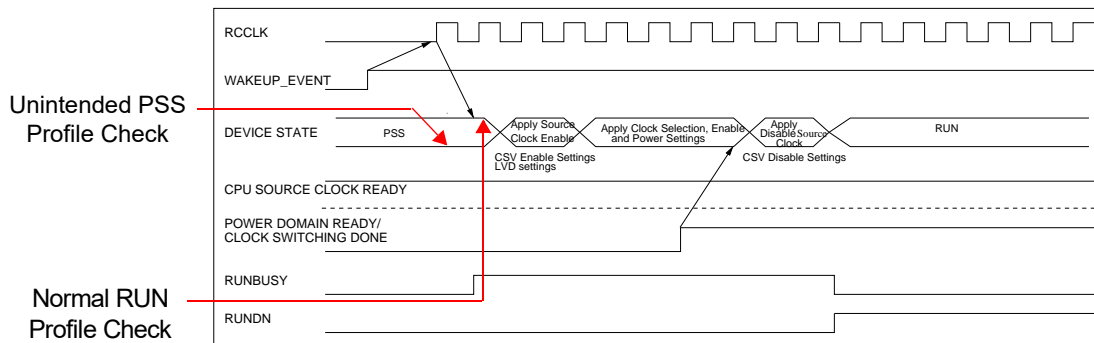

Refer to the 002-09388_0C_FCR4_Cluster Series HWM.pdf, Chapter 2.3.2.6 PSS to RUN State Switching", page 282.

Generally, the unintended PSS profile check has no effect because of the PSS profile was already checked at the preceding RUN to PSS transition. However, at startup, the following invalid PSS profile setting rule builds an exception:

- An LVD is switched on (i.e. the LVD is off in APP profile and on in PSS profile) or an LVD threshold is changed (i.e. the LVD threshold differs between APP and PSS profiles) when the RC oscillator is disabled in the PSS profile. This check is necessary to make sure the RC clock is available for the stabilization time of the LVD

Refer to the 002-09388_0C_FCR4_Cluster Series HWM.pdf, Chapter 2.3.2.9 PSS Profile - Invalid PSS Profile Settings for RUN to PSS Transitions, page 286.

After wakeup, the APP profile of LVD already holds the settings for RUN state. Now, the mentioned rule compares the LVD threshold settings (APP differ from PSS?), and if the RC oscillator is disabled in PSS, the rule is fulfilled, the PSS profile error flag `SYSC_SY-SERRR:PSSERRIF` is set and NMI is triggered.

14. PSS Wakeup Problem (Continued)	
Workaround	Do not use the combination of settings mentioned in the above Problem Condition . If the mentioned combination of settings was applied, execute and handle this particular NMI exception by ignoring it once after every wake-up.
Fix Status	No fixes planned.

15. Undefined Data under Certain Conditions when Reading the Flash Memory	
Overview	This functional limitation is that invalid data may be read from the TCM interface when changing the wait state setting of the Flash interface or at concurrent TCM port and AXI port accesses to the Flash memory on 32-bit FCR4 Cluster Series MCUs.
Parameters Affected	All part numbers of the CY9EF226 series are affected.
Details of the Limitation	<p>The Flash memory is connected via the TCFLASH_IF to the CPU and the High Performance bus Matrix (HPM) as shown in Figure 29. The TCM port of this interface is the direct connection to the TCM port of the CPU and the AXI port is the connection to the HPM.</p> <p>Invalid data may be read from the TCM port of the Flash memory at the following two conditions:</p> <ul style="list-style-type: none"> ■ The wait state setting of the Flash interface can be changed by writing to register TCFCF-G_FCFGR:FAWC[1:0]. If the Wait state setting is changed while the Flash is read via the TCM interface, then invalid data may be read from the TCM port of the Flash interface. ■ If the Flash is read via the TCM port while there is a concurrent access via the AXI port, then invalid data may be read from the TCM port of the Flash interface.

Figure 29. Connection of Flash Memory

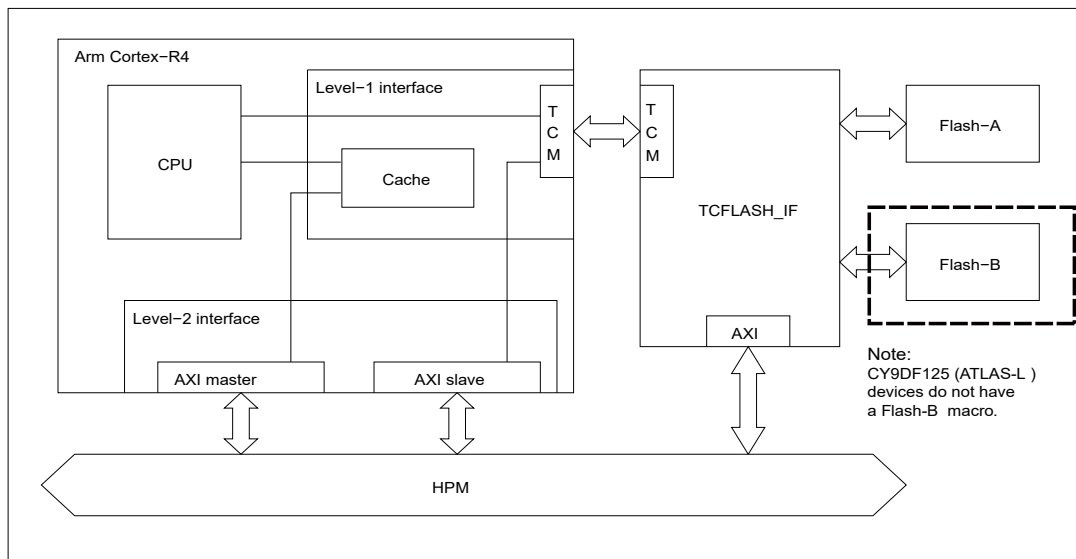

Note:
CY9DF125 (ATLAS-L)
devices do not have
a Flash-B macro.

15. Undefined Data under Certain Conditions when Reading the Flash Memory (Continued)	
Workaround	<p>For issue no. 1, avoid changing the wait state setting of the Flash interface while reading from the Flash interface via the TCM port. Use the default setting of TCFCFG_FCFGR:FAWC[1:0] instead. The default setting is 1 wait state which is sufficient to run the CPU with the maximum specified clock.</p> <p>In case it is unavoidable to change wait state settings, make sure there are no accesses to the Flash memory via the TCM port. For example, execute code from a routine previously copied to RAM.</p> <p>For issue no. 2, access the Flash memory only in one of the following ways:</p> <ol style="list-style-type: none"> a. Access the Flash memory only via the AXI interface. b. Access the Flash memory only via the TCM interface. <p>In this case, ensure no xmaster is accessing the Flash memory via the AXI interface. Accesses by other masters than the CPU can be detected by using the Memory Protection Unit (MPU) for AXI and the MPU for AHB. See <i>FCR4 Cluster Series Hardware Manual</i> for details how to use the MPU.</p> <p>To allow access by other masters to the Flash memory, such masters should use the address range of the AXI slave interface of the CPU where the TCFLASH is also mapped. That would use the arbitration logic within the CPU and the Flash interface would face only accesses through its TCM port. For details of the memory map, refer to <i>FCR4 Cluster Series Hardware Manual, chapter 1</i>, symbols AXI_SLAVE_CORE0_TCM_FLASH_SMALL_SECTORS, AXI_SLAVE_CORE0_TCM_FLASH_LARGE_SECTORS</p>
Fix Status	No fixes planned. SW workaround is available.

Ordering Information

Table 96 lists the CY9EF226 series key package features and ordering codes. The table contains only the parts that are currently available. If you do not see what you are looking for, contact your local sales representative. For more information, visit the Cypress website at www.cypress.com and refer to the product summary page at <http://www.cypress.com/products>.

Table 96. Ordering Information

Part Number	Package	Remarks
CY9EF226BPMC-GSE2	176-pin plastic LQFP LQP176	Lead-free package 4 SMC variant
CY9EF226EBPMC-GSE2	176-pin plastic LQFP LQP176	Lead-free package 6 SMC variant
CY9EF226LBPMC-GSE2	176-pin plastic LQFP LQP176	Lead-free package 4 SMC variant w/o graphic subsystem

Appendix

Workaround for Flash Erase Suspend Issue

To avoid this limitation, the following workaround by software is recommended.

After the flash sector erase suspend operation (issue of the suspend command + verification of DQ6/TOGG1 bit) is finished, check the hardware sequence flag DQ4 bit indicating the specific internal state which can read flash or not (see Figure 30).

If the value of DQ4 bit is "1", then issue the sector erase resume command and restart the sector erase suspend operation after the waiting time.

Figure 30. Workaround by Software

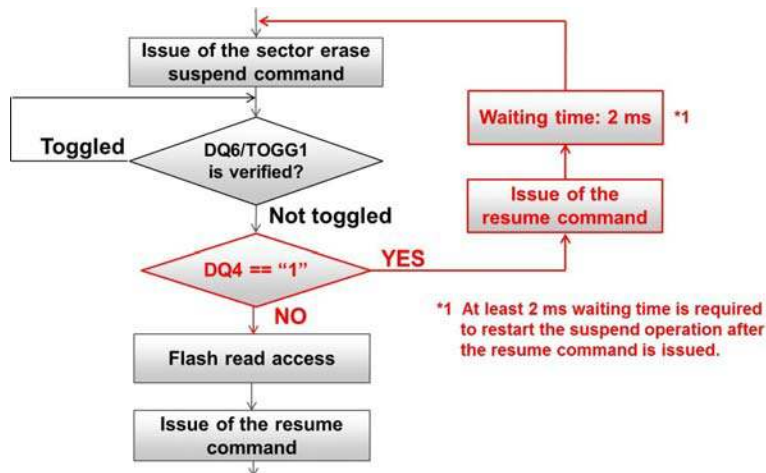

Please note the following factors of internal circuit when using the software workaround:

- At least 2 ms waiting time is required to restart the sector erase suspend operation after the resume command is issued by DQ4 = "1" (see *1 in Figure 30).

- Approximately a maximum of 10 ms would be required for DQ4 to become "0" after the suspend command is issued first.

Though DQ4 is an undefined bit on the hardware manual, it can be used to read the internal sequence state. If DQ4 == "0", it indicates the internal state allowing data read/instruction fetch from flash. But if DQ4 == "1", internal circuit have not changed to the state allowing data read/instruction fetch. See the following table and figure representing bit assignment of DQ4 bit for FCR4 family and FR5 family, respectively. See Table 97 and Figure 30 representing bit assignment of DQ4 bit for FCR4 family and FR5 family, respectively.

Table 97. Bit Assignment of Hardware Sequence Flags (Cypress Cortex R4 Family)

Read data bit no.	7	6	5	4	3	2	1	0
Hardware sequence flag	DQ7	DQ6	DQ5	DQ4	DQ3	DQ2	-	-
Read data bit no.	15	14	13	12	11	10	9	8
Hardware sequence flag	DQ15	DQ14	DQ13	-	DQ11	DQ10	-	-

Workaround for IRQ Unit Register Read Timing Issue

General Considerations

It is assumed that for normal operation of the MCU and most use cases it is not necessary to read back any I-Unit registers, i.e. the application software e.g. knows which vector addresses are configured, which priorities are set, and which IRQ channels are enabled.

Furthermore, it is assumed that for IRQ handling the application enables the Arm VIC port which is not affected by the read timing issue.

It is not necessary to poll the I-Unit lock status bit (IRQ0_CSR_LST) after unlocking/locking the I-Unit. This bit does not indicate any I-Unit internal time consuming operations. Its purpose is to inform the application about the current lock state so that exceptions caused by double unlocking or locking can be avoided. This can also be implemented with software means (e.g. semaphore).

For debugging during development or error logging purposes, it may be useful to read certain status registers from the I-Unit (e.g. IRQ0_IRQST, IRQ0_EAN) which still can be done but it must be regarded that the gathered information may not be reliable.

Considering above mentioned assumptions the only functionality that is affected by the read timing issue is the NMI handling. FCR4 MCUs by default use the Arm "high exception vectors" option with exception vector table located at address 0xFFFF0000. This area is implemented as ROM and its contents are not changeable. The instruction placed at the FIQ exception vector (**Note** FIQ and NMI are used synonymously throughout the document) will read from the NMIVAS mirror register at address 0xFFFEFBFC to retrieve the branch target. Due to the read timing issue, the target address is not reliable and the read must be prevented.

Following two workarounds exist to overcome this situation and still provide NMI functionality:

- Workaround #1: Using Memory Protection Unit -> preventing the read from NMIVAS mirror
- Workaround #2: Using Arm "low exception vector" option -> allowing to replace the instruction at FIQ exception vector

All described preparatory steps in these workarounds (e.g. MPU configuration) must be completed before application enables NMIs (clearing of 'F'-bit in CPU Current Program Status Register).

If these workarounds are used, it is also not necessary to initialize the NMI specific I-Unit registers (NMI priorities, NMI vectors)

Software samples are provided to demonstrate both workarounds:

- Workaround #1: fcr4_nmi_mpu_mbxxxx-vxx
- Workaround #2: fcr4_nmi_low_exception_mbxxxx-vxx

Workaround #1 (MPU)

Overview

This workaround aims to detect the read access to the IRQ0_NMIVAS mirror register from the instruction at the FIQ exception vector. The NMIVAS mirror register is located at address 0xFFFFEFBFC which will be secured by a memory protection region supported by the Arm core MPU.

The flowchart below introduces the process of the workaround when the application code is interrupted by an NMI event.

Figure 31. Workaround #1 Software Flow

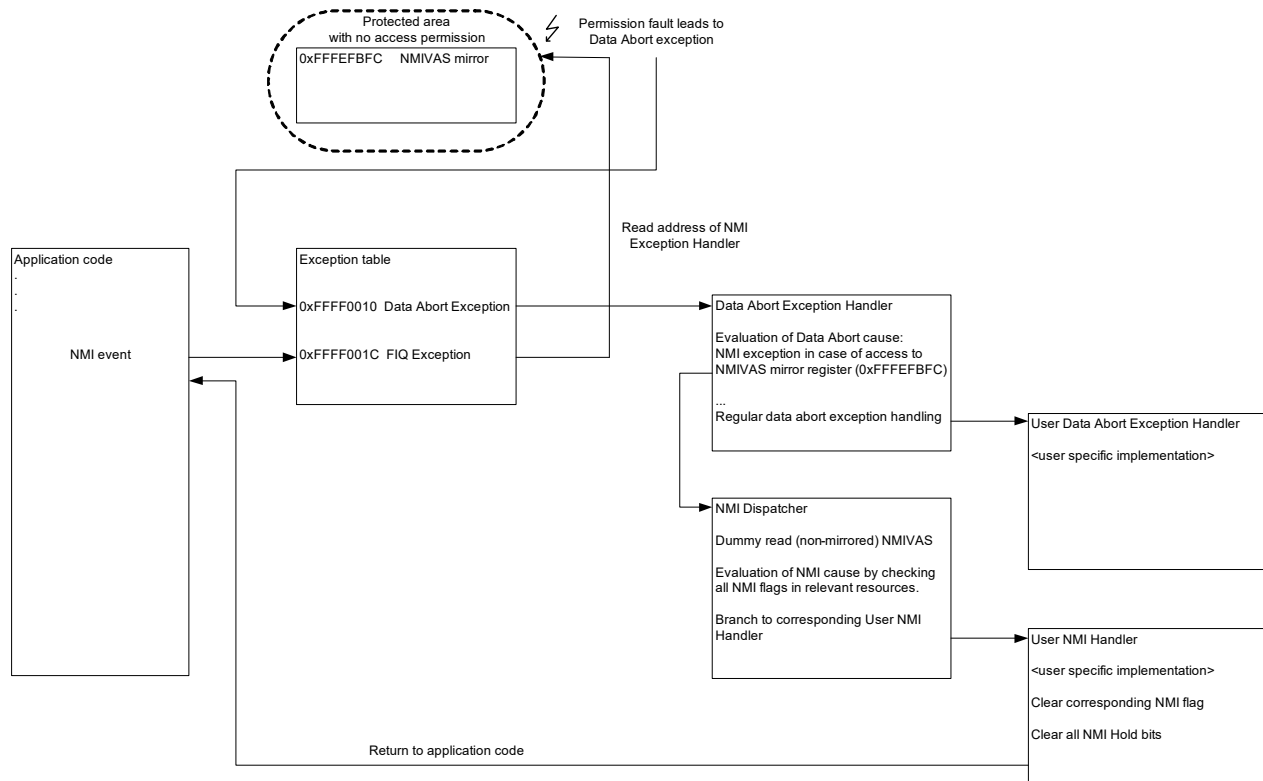

Problem Description

1. Each non-maskable interrupt will cause an FIQ exception and the instruction at address 0xFFFF001C is executed. The instruction reads the vector for the NMI exception handler. This vector is determined by the I-Unit and made available via NMIVAS register and because of the specified hardware fault in the I-Unit cannot be read reliably. To prevent a branch to a corrupted NMI vector address, the access to NMIVAS mirror register at address 0xFFFFEFBFC must be protected by an Arm MPU region.

2. When the FIQ exception instruction accesses the NMIVAS mirror register, a Data Abort exception will occur because of the MPU protection.

3. After the Data Abort handler is entered, the Data Fault Status Register (DFSR) and Data Fault Address Register (DFAR) which are located in System Control coprocessor and the CPU Link Register (R14) are evaluated to determine whether the Data Abort was caused by the occurrence of an NMI.

Conditions for NMI cause:

- Data Fault Status Register
DFSR[10,3:0] = 0b01101 (Permission Fault)
DFSR[11] = 0 (read access)
- Data Fault Address Register
DFAR = 0xFFFFEFBFC (NMIVAS mirror register)
- Link Register R14_abt = 0xFFFF0024 shows that an NMI caused the abort (0xFFFF001C + 0x8)

Before evaluation starts, all CPU registers modified by the code are pushed on Data Abort stack (R13_abt).

4. There are two cases depending on this evaluation result:

a. In case not all conditions are true, the Data Abort was not caused by the occurrence of an NMI.

The modified registers are restored from the stack and the Data Abort handler branches to the user's Data Abort handler ("branch without link" -> Link Register is not modified). This behavior is transparent for the user's Data Abort handler which can be written assuming that the handler is directly executed from a Data Abort exception.

b. In case all conditions are true, the Data Abort was caused by the occurrence of an NMI.

Data Fault Status and Data Fault Address register are explicitly cleared to prevent a repetitive NMI handling in case an NMI occurred shortly after a "normal" Data Abort. After that, the modified registers are restored from the stack and the CPU mode is changed from "Abort" to "FIQ".

The program continues at NMI Dispatcher function where a dummy read to the NMIVAS register is done, because this read has the I-Unit internal effect of deasserting the nFIQ CPU signal and setting the NMI Hold bit of the NMI which has won I-Unit priority decision.

Finally, the NMI cause must be evaluated. This is done by checking all NMI flags in the corresponding peripheral resources (availability may vary for different FCR4 derivatives). As it is not possible to reliably read the I-Unit ECC Double Bit Error NMI flag (IRQ0_EEI_EENS), the software must assume that this is the NMI cause in case no other NMI is present. Once the NMI cause has been detected, the software can branch to the user's NMI handler. Before doing the "branch without link", the stack and registers should be restored (if used by NMI Dispatcher), as the user handler will directly return to the program location where the NMI occurred.

5. The user NMI handler must be changed as described in "[Changes to User NMI Handler](#)" on page 316. It will directly return to the application code.

Arm MPU Configuration

The MPU is a part of Cortex-R4 MCU and can be configured via System Control Coprocessor. It controls the accesses to defined memory regions with the configuration of permission rights.

For protection of NMIVAS mirror register, this function will be used as follows.

The setup of MPU is done by defining:

- Region number
- Region access permissions
- Region size and enable setting
- Region base address

The region number with the highest priority ('11') must be chosen.

The access permission must be set to 'No Access' in User and in Privileged Mode.

The region size (bit 5..1) is set to minimum size (32 byte) which will not influence any other used memory area. Bit 0 enables the configured MPU setup.

It must be ensured that the region base address is 32 byte aligned and the NMIVAS mirror address is within the given region size.

In addition, two more settings in the System Control Register (also located in System Control Coprocessor) must be done for activating the MPU function:

- M (bit 0) = 1: MPU enable
- BR (bit 17) = 1: MPU background region enable

Refer to the Arm Cortex-R4 Technical Reference Manual and the provided software sample for information on how to configure and enable the MPU.

Configuration Sequence

The following configuration sequence for this workaround is recommended:

1. Reset (High Exception Vectors active, FIQ/NMI masked, IRQ masked).
2. Configure MPU to prohibit access to NMIVAS mirror register.
3. Enable NMI processing in CPU (clear 'F'-bit in CPSR register).
4. Configure IRQ vector table, priority levels and channel enable status in I-Unit.
5. Enable VIC port (to enable IRQ processing via not-affected VIC port).
6. Enable IRQ processing in I-Unit (IRQ0_CSR_IRQEN).
7. Enable IRQ processing in CPU (clear 'I'-bit in CPSR register).

Workaround Limitations

The following limitations need to be considered, if this workaround is used:

- NMI dispatcher and all called NMI handlers must not allow NMI nesting.

If NMIs would be re-enabled (clearing of 'F'-bit in CPU Current Program Status Register), another NMI exception could occur. In case the NMI flag of the already handled NMI is evaluated again by the new/nested NMI Dispatcher function, the same handler will be called again. Further error scenarios are imaginable which can also result in some inconsistent state.

- Return from a "normal" Data or Prefetch Abort may not be possible.

It can happen that while a "normal" Data or Prefetch Abort handler is currently executed, an NMI occurs because they are not masked on Abort exception entry. As a consequence, this NMI will lead to another Data Abort exception that overwrites the original SPSR_abt and R14_abt CPU register values, and the Fault Status Registers in the System Control Coprocessor. This makes it impossible for the user's Data or Prefetch Abort handler to return to application or correctly evaluate the circumstances (for example, program location and processor state) of the original Abort.

Basically, a similar behavior can occur on any Armv7-R architecture if another precise Abort occurs while an Abort handler is executed.

Workaround #2 (Low Exception)

Overview

The application needs to set up an exception table at the "low exception table" location at address 0x0 (inside TCMRAM) and afterwards make this the active table. With this solution, the instruction at the FIQ exception vector can be chosen arbitrarily and the read to NMIVAS register is avoided.

Problem Description

Preconditions

For the implementation shown in the software samples, the linker settings of the application must ensure that 64 bytes starting from address 0x0 are reserved for the low exception table and corresponding handler addresses (address area 0x00 - 0x3F).

Exception Table Setup

The exception table in Armv7-R architecture is defined as provided in [Table 98](#).

Table 98. Armv7-R Exception Table

Offset to Table Base (0x0 or 0xFFFF0000)	Exception Type
0x00	Reset
0x04	Undefined Instruction
0x08	Supervisor Call / (Software Interrupt)
0x0C	Prefetch Abort
0x10	Data Abort
0x14	Reserved
0x18	IRQ (if VIC port disabled)
0x1C	FIQ

Typically, a LDR PC, [PC, #+/-<imm>] instruction is placed at each of these exception vectors which will do a 32-bit read at a PC-relative location and move this value to the PC (= branch to this address). In Arm terminology, the data that is read are called "literals". These literals are the addresses of the corresponding exception handler functions.

In the sample software, the exception table and literals are setup as provided in [Table 99](#).

Table 99. Exception Table Setup in Sample Software

Absolute Address	Content
0x00	don't care (on reset high exception table is getting active anyway)
0x04	LDR PC, [PC, #+0x18]
0x08	LDR PC, [PC, #+0x18]
0x0C	LDR PC, [PC, #+0x18]
0x10	LDR PC, [PC, #+0x18]
0x14	don't care
0x18	LDR PC, [PC, #+0x18]
0x1C	LDR PC, [PC, #+0x18]
0x20	don't care
0x24	Address of Undefined Instruction handler
0x28	Address of Supervisor Call handler
0x2C	Address of Prefetch Abort handler
0x30	Address of Data Abort handler
0x34	don't care
0x38	Address of IRQ handler (in case VIC port disabled)
0x3C	Address of special NMI dispatcher function (see Problem Description of NMI Dispatcher)

The offset value in the LDR PC, [PC, #+0x18] instruction regards the fact that in Armv7-R architecture, the PC always points to the address of the currently executed instruction + 0x8 → 0x18 + 0x8 = 0x20 offset between instruction and corresponding literal.

MPU protection of low exception table (optional)

Especially when considering the probability of immature software using uninitialized NULL pointers, it is recommended to protect the low exception table and related literals against accidental write accesses by setting up a read-only MPU region for that address area.

Refer to the Arm Cortex-R4 Technical Reference Manual and the provided software sample for information on how to configure and enable the MPU.

Switching the active exception table

To make the low exception table active, the 'V' bit (bit 13) in the System Control Register of the System Control Coprocessor must be cleared.

Problem Description of NMI Dispatcher

The same NMI Dispatcher as for Workaround #1 is also used for Workaround #2.

This function executes a dummy read to the NMIVAS register, because this read has the I-Unit internal effect of deasserting the nFIQ CPU signal and setting the NMI Hold bit of the NMI which has won I-Unit priority decision. Finally, the NMI cause must be evaluated. This is done by checking all NMI flags in the corresponding peripheral resources (availability may vary for different FCR4 derivatives). As it is not possible to reliably read the I-Unit ECC Double Bit Error NMI flag (IRQ0_EEI_EENS), the software must assume that this is the NMI cause in case no other NMI is present. Once the NMI cause has been detected, the software can branch to the user's NMI handler. Before doing the "branch without link", the stack and registers should be restored (if used by NMI Dispatcher), as the user handler will directly return to the program location where the NMI occurred.

The user NMI handler must be changed as described in "[Changes to User NMI Handler](#)" on page 316.

Configuration Sequence

The following configuration sequence for this workaround is recommended:

1. Reset (High Exception Vectors active, FIQ/NMI masked, IRQ masked).
2. Create Low Exception Vector table at 0x00000000.
3. Configure MPU to protect exception vector table in TCMRAM.
4. Switch to Low Exception Vector table.
5. Enable NMI processing in CPU (clear 'F'-bit in CPSR register).
6. Configure IRQ vector table, priority levels, and channel enable status in I-Unit.
7. Enable VIC port (to enable IRQ processing via not-affected VIC port).
8. Enable IRQ processing in I-Unit (IRQ0_CSR_IRQEN).
9. Enable IRQ processing in CPU (clear 'I'-bit in CPSR register).

Workaround Limitations

Following limitations need to be considered, if this workaround is used:

- NMI dispatcher and all called NMI handlers must not allow NMI nesting.

If NMIs would be re-enabled (clearing of 'F'-bit in CPU Current Program Status Register), another NMI exception could occur. In case the NMI flag of the already handled NMI is evaluated again by the new/nested NMI Dispatcher function, the same handler will be called again. Further error scenarios are imaginable which can also result in some inconsistent state.

Changes to User NMI Handler

The limitation and workarounds covered by this document result in necessary changes to the user NMI handlers.

A different NMI handler exit code is required for correct operation. Instead of only clearing the corresponding NMI Hold bit, all NMI Hold bits must be cleared (as currently set Hold Bit cannot be read back from I-Unit).

If this is not done, a problem can occur in case of multiple pending NMIs. The software NMI dispatcher may have evaluated a different "winning" NMI than the I-Unit hardware logic (in case of multiple pending NMIs), because it uses the resource NMI flags to determine pending NMIs. Consequently, the NMI Hold bit would not be cleared by the user NMI handler and this prevents the I-Unit from asserting the nFIQ signal to CPU again for this still pending and not yet handled NMI.

Ordering of NMI Flag Evaluation

In the event of an NMI, no information can be read from the I-Unit, hence the NMI flag(s) of all resources that can generate NMIs need to be evaluated.

Following order of NMI flag evaluation is used in the provided software samples:

1. Low voltage detection NMI
2. System controller error NMI
3. External NMI pin
4. Watchdog NMI
5. Timing Protection Unit NMI
6. MPU DMA Access Violation NMI
7. MPU IRIS Access Violation NMI (if available)
8. MPU MLB0 Access Violation NMI (if available)
9. Bus Error Collection Unit BECU0 Access Violation (Peripheral group 0)
10. Bus Error Collection Unit BECU1 Access Violation (Peripheral group 1)
11. Bus Error Collection Unit BECU3 Access Violation (Peripheral group 3)
12. Iris Signature Unit NMI (if available)
13. MPU SHE Access violation (if available)
14. IRQ Double Error NMI

The order may be re-arranged to decrease NMI latency for certain use cases, except "IRQ Double Error NMI", which must remain on last position as it must be determined by exclusion principle.

Writing I-Unit Registers

Care must be taken when writing code for the initialization of I-Unit registers.

Any code that would result in RMW (Read-Modify-Write) accesses must be avoided. RMW accesses may be generated if register bit field types are used for assigning values.

Example:

If priority level for IRQ channel 2 shall be set to 19:

C-Code: `IRQ0_IRQPL0_IRQPL2 = 19;` (**wrong!**)

Compiler Output: 32-bit read of IRQ0_IRQPL0 register

Modify bits belonging to IRQPL2 bit field

32-bit write of IRQ0_IRQPL0 register

Because the read of this RMW access is affected by the limitation described in this Customer Information, a possibility that other priority levels in the same register are getting corrupted exists.

Workaround for IUNIT Interrupt Handling Problem

1. To change the IRQ Priority Level Mask Register (IRQ0_IRQPLM), use the following workaround:
 - a. Safe sequence to change IRQ0_PLM (temporarily disable interrupt processing and perform wait until IUNIT idle)

```
SuspendAllInterrupts();           // globally disable all IRQs with
// 'I'-bit in CPU CPSR
IRQ0_UNLOCK = <unlock-key>;
IRQ0_CSR = 0;                     // setting IRQEN bit to '0'
IRQ0_CSR;                         // dummy read to generate wait cycles
// until state machine has returned to
// idle state
IRQ0_IRQPLM = <new PLM value>;
IRQ0_CSR = 1;                     // setting IRQEN bit to '1'
IRQ0_UNLOCK = <lock-key>;
ResumeAllInterrupts();           // restore previous state of 'I'-
// bit in CPU CPSR
```

- b. Extension for each ISR entry code (check if corresponding IRQ0_IRQPL[n] < current IRQ0_IRQPLM)
Pseudocode:

```
__interrupt void Interrupt_1_Handler(void)
{
    // Check if priority of current IRQ is higher (means lower value)
    // than the currently active priority level mask
    if (Interrupt_1_Prio < Current_PLM_Value)
    {
        // The interrupt is "valid" and corresponding code
        // shall be executed
        // Call user callback function, which is also responsible
        // for clearing the interrupt flag in the peripheral
        ....
    }

    // Clear Hold-Bit of Interrupt_1
    ...
}
```

IMPORTANT:

“Interrupt_1_Prio” must be determined indirectly by the called ISR and OS/application internal interrupt priority configuration variable(s).

IRQ0_IRQPL0~127 and IRQ0_IRQST:IRQSN must not be read. (see [“Workaround for IRQ Unit Register Read Timing Issue”](#) on page 311)

Current_PLM_value must be read from OS/application internal buffer variable IRQ0_IRQPLM must not be read. (see [“Workaround for IRQ Unit Register Read Timing Issue”](#) on page 311).

Current_PLM_value must be read from OS/application internal buffer variable IRQ0_IRQPLM must not be read. (see [“Workaround for IRQ Unit Register Read Timing Issue”](#) on page 311)

2. To avoid changing the priority level of an active IRQ interrupt, configure IRQ0_IRQPL0~127 only in initial phase before enabling interrupts by setting IRQ0_CSR.IRQEN=1.

With the software workaround explained in [“Workaround for IRQ Unit Register Read Timing Issue”](#) on page 311, it is not necessary to change IRQ0_NMIPL0~7.

3. IRQ Hold Clear - use following sequence to clear the bit:

```
IRQ0_UNLOCK = <unlock-key>
IRQ0_CSR = 0;           // setting IRQEN bit to '0'
IRQ0_CSR;              // dummy read to generate wait cycles
// until IRQ is latched in IUNIT, resp.
// state machine returned to idle state
IRQ0_IRQHC = <IRQ-Nr>   // clear Hold-bit of IRQ
IRQ0_CSR = 1;          // setting IRQEN bit to '1'
IRQ0_UNLOCK = <lock-key>
```

NMI Hold Clear - use following workaround:

NMI handling shall be implemented according to workarounds in [“Workaround for IRQ Unit Register Read Timing Issue”](#) on page 311 (will not use any potential wrong NMI register values, as reading is prohibited anyway).

4. Perform write access to IRQ0_IRQHC only with 16-bit or 32-bit access width.

Document History Page

Document Title: CY9EF226 - Titan, CY9EF226 Series				
Document Number: 002-05678				
Rev.	ECN No.	Orig. of Change	Submission Date	Description of Change
**	-	-	09/01/2015	Initial draft
				Corrected pinout for 176pin and 240pin variant
				Updated electrical characteristics, procedures, io map. added device handling, order information
				New IO Map tables included; Corrections to RICFG tables
				Updated part numbers, removed preliminary
				Added CY9EF226L part number for non graphics variant
				Updated IO Map tables: corrected addresses 0xb0400aa8 0xb070005c-0xb0707ffe 0xb07fa46a-0xb07ffffe 0xb0c02900-0xb0cffffc 0xffffef000-0xffffeff8 corrected default values of IRQ0_NMIPL0, IRQ0_IRQPL0, IRQ0_IRQPL12, IRQ0_IRQPL13, EECFG_EMENR
*A	5300963	GESC	07/01/2016	Updated to Cypress template. Updated CY Logo and Sales Disclaimer. Added Features . Incorporated all customer information documents into the Errata . Updated references to "Pin State while Power-On-Reset" in section title, section text, and table title for Table 79 , in Pin State During Active External Reset . Updated Table 2 : Removed "Power on Reset (PoR)" from the list of Resets. Removed PT_TESTPAD in Figure 1. Updated Figure 1. Added ESD Structure between Power Domains . Updated Ordering Information . Added Document Definition in Reference Documents .
*B	5981420	NOFL	12/21/2017	Added ordering information: CY9EF226PMC-GSK5E2, CY9EF226BPMC-GSK5E2, CY9EF226EPMC-GSK5E2, CY9EF226EBPMC-GSK5E2, CY9EF226LPMC-GSK5E2, CY9EF226LBPMC-GSK5E2. Updated package name from FPT-176P-M07 to LQP176. Removed QFP240 references in the entire document.
*C	6557075	NOFL	04/25/2019	Replaced all references to MB9EF226 with CY9EF226. Updated Errata and Ordering Information . Updated Copyright information.

Sales, Solutions, and Legal Information

Worldwide Sales and Design Support

Cypress maintains a worldwide network of offices, solution centers, manufacturer's representatives, and distributors. To find the office closest to you, visit us at [Cypress Locations](#).

Products

Arm [®] Cortex [®] Microcontrollers	cypress.com/arm
Automotive	cypress.com/automotive
Clocks & Buffers	cypress.com/clocks
Interface	cypress.com/interface
Internet of Things	cypress.com/iot
Memory	cypress.com/memory
Microcontrollers	cypress.com/mcu
PSoC	cypress.com/psoc
Power Management ICs	cypress.com/pmic
Touch Sensing	cypress.com/touch
USB Controllers	cypress.com/usb
Wireless Connectivity	cypress.com/wireless

PSoC[®] Solutions

[PSoC 1](#) | [PSoC 3](#) | [PSoC 4](#) | [PSoC 5LP](#) | [PSoC 6 MCU](#)

Cypress Developer Community

[Community](#) | [Projects](#) | [Video](#) | [Blogs](#) | [Training](#) | [Components](#)

Technical Support

cypress.com/support

© Cypress Semiconductor Corporation, 2015-2019. This document is the property of Cypress Semiconductor Corporation and its subsidiaries ("Cypress"). This document, including any software or firmware included or referenced in this document ("Software"), is owned by Cypress under the intellectual property laws and treaties of the United States and other countries worldwide. Cypress reserves all rights under such laws and treaties and does not, except as specifically stated in this paragraph, grant any license under its patents, copyrights, trademarks, or other intellectual property rights. If the Software is not accompanied by a license agreement and you do not otherwise have a written agreement with Cypress governing the use of the Software, then Cypress hereby grants you a personal, non-exclusive, nontransferable license (without the right to sublicense) (1) under its copyright rights in the Software (a) for Software provided in source code form, to modify and reproduce the Software solely for use with Cypress hardware products, only internally within your organization, and (b) to distribute the Software in binary code form externally to end users (either directly or indirectly through resellers and distributors), solely for use on Cypress hardware product units, and (2) under those claims of Cypress's patents that are infringed by the Software (as provided by Cypress, unmodified) to make, use, distribute, and import the Software solely for use with Cypress hardware products. Any other use, reproduction, modification, translation, or compilation of the Software is prohibited.

TO THE EXTENT PERMITTED BY APPLICABLE LAW, CYPRESS MAKES NO WARRANTY OF ANY KIND, EXPRESS OR IMPLIED, WITH REGARD TO THIS DOCUMENT OR ANY SOFTWARE OR ACCOMPANYING HARDWARE, INCLUDING, BUT NOT LIMITED TO, THE IMPLIED WARRANTIES OF MERCHANTABILITY AND FITNESS FOR A PARTICULAR PURPOSE. No computing device can be absolutely secure. Therefore, despite security measures implemented in Cypress hardware or software products, Cypress shall have no liability arising out of any security breach, such as unauthorized access to or use of a Cypress product. CYPRESS DOES NOT REPRESENT, WARRANT, OR GUARANTEE THAT CYPRESS PRODUCTS, OR SYSTEMS CREATED USING CYPRESS PRODUCTS, WILL BE FREE FROM CORRUPTION, ATTACK, VIRUSES, INTERFERENCE, HACKING, DATA LOSS OR THEFT, OR OTHER SECURITY INTRUSION (collectively, "Security Breach"). Cypress disclaims any liability relating to any Security Breach, and you shall and hereby do release Cypress from any claim, damage, or other liability arising from any Security Breach. In addition, the products described in these materials may contain design defects or errors known as errata which may cause the product to deviate from published specifications. To the extent permitted by applicable law, Cypress reserves the right to make changes to this document without further notice. Cypress does not assume any liability arising out of the application or use of any product or circuit described in this document. Any information provided in this document, including any sample design information or programming code, is provided only for reference purposes. It is the responsibility of the user of this document to properly design, program, and test the functionality and safety of any application made of this information and any resulting product. "High-Risk Device" means any device or system whose failure could cause personal injury, death, or property damage. Examples of High-Risk Devices are weapons, nuclear installations, surgical implants, and other medical devices. "Critical Component" means any component of a High-Risk Device whose failure to perform can be reasonably expected to cause, directly or indirectly, the failure of the High-Risk Device, or to affect its safety or effectiveness. Cypress is not liable, in whole or in part, and you shall and hereby do release Cypress from any claim, damage, or other liability arising from any use of a Cypress product as a Critical Component in a High-Risk Device. You shall indemnify and hold Cypress, its directors, officers, employees, agents, affiliates, distributors, and assigns harmless from and against all claims, costs, damages, and expenses, arising out of any claim, including claims for product liability, personal injury or death, or property damage arising from any use of a Cypress product as a Critical Component in a High-Risk Device. Cypress products are not intended or authorized for use as a Critical Component in any High-Risk Device except to the limited extent that (i) Cypress's published data sheet for the product explicitly states Cypress has qualified the product for use in a specific High-Risk Device, or (ii) Cypress has given you advance written authorization to use the product as a Critical Component in the specific High-Risk Device and you have signed a separate indemnification agreement.

Cypress, the Cypress logo, Spansion, the Spansion logo, and combinations thereof, WICED, PSoC, CapSense, EZ-USB, F-RAM, and Traveo are trademarks or registered trademarks of Cypress in the United States and other countries. For a more complete list of Cypress trademarks, visit cypress.com. Other names and brands may be claimed as property of their respective owners.