

# SST-20-B

## Blue LED

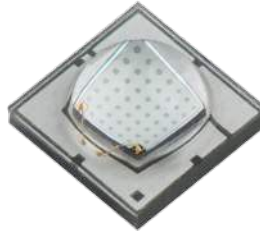

### Table of Contents

SST-20 Binning Structure . . . 2

Part Numbering and Bin Kit Information . . . . . 3

Optical and Electrical Characteristics . . . . . 4

A120 - Mech. Dimensions . . . 6

B120 - Mech. Dimensions . . . 7

A120/B120 - Tape and Reel . . 8

Reel Packaging . . . . . 9

Box Packaging Info . . . . . 10

Soldering Profile . . . . . 11

Precautions for Use . . . . . 12

History of Changes . . . . . 13

### Features:

- High Power Blue LED with Peak Wavelength of 450nm
- Typical Wall-Plug Efficiency of 72% at 350 mA
- Maximum drive current: 3 A
- Available with 2 industry standard soldering footprint configurations
- High thermal conductivity package - junction thermal resistance of only 3.5°C/W
- Available with 120° viewing angle
- 8000V HBM ESD rating per MIL STD-883D
- Electrically isolated thermal path
- RoHS and REACh compliant

### Applications

- Horticulture / Growlights
- Accent and effect lighting
- Architectural lighting
- Remote-phosphor fixtures
- Stage lighting

## SST-20 Binning Structure

SST-20 Blue LEDs are tested for luminous flux and chromaticity at a drive current of 350mA - 20ms single pulse and placed into one of the following luminous flux (FF) and chromaticity (WW) bins:

### Flux Bins - Test condition=350mA, 25°C, 20ms pulse

Flux Bin (FF)	Minimum Flux (mW)	Maximum Flux (mW)
R	630	670
S	670	710
T	710	750
U	750	790
V	790	830

### Wavelength Bins - Test condition=350mA, 25°C, 20ms pulse

Chromaticity Bin (WW)	Minimum Wavelength (nm)	Maximum Wavelength (nm)
B2	440	445
B3	445	450
B4	450	455
B5	455	460

\*Note: Luminus maintains a +/- 6% tolerance on flux measurements.

## Ordering Information

Products	Ordering Part Number	Description
SST-20-B-A120	SST-20-B-A120-xx123	High Power 2-mm <sup>2</sup> Blue LED in a 3535 surface mount package and a 120-degree viewing angle - Type A soldering pad configuration
SST-20-B-B120	SST-20-B-B120-xx123	High Power 2-mm <sup>2</sup> Blue LED in a 3535 surface mount package and a 120-degree viewing angle - Type B soldering pad configuration

### Part Number Nomenclature

SST — 20 — <A> — <PAA(A)> — <FCCC>

Product Family	LED Emission Area	Color	Package Configuration	Bin kit
SST: Surface Mount Package	20: 2.0 mm <sup>2</sup>	<A>: Color B = Blue	P: Soldering pad configuration A type - see page 6 B type - see page 7 AA(A): Viewing angle 120°	See Tables F = minimum flux bin CCC: Chromaticity bin kit

### SST-20 Bin Kit Order Codes

The following table describes the bin kit ordering codes available for the SST-20 Blue LEDs. Each bin kit specifies a minimum flux as well as specific chromaticity bins allowed. Please note that within each kit a maximum flux is not specified and as a result Luminus may ship any part meeting or exceeding the minimum flux specification. Shipments will always meet the listed chromaticity bins. For information on ordering bin kits not listed below, please contact Luminus.

#### SST-20 Blue Bin Kit Order Codes

Color	Luminous Flux		Chromaticity Bins	Kit Number
	Bin Kit Flux Code	Min. Flux		
Blue	R	630	B2,B3,B4,B5	R450
	S	670	B2,B3,B4,B5	S450
	T	710	B2,B3,B4,B5	T450

### Product Shipping & Labeling Information

All SST-20 products are packaged and labeled with their respective bin as outlined in the tables on pages 2 & 3. Each reel will only contain one bin.

#### SST-20 Blue

SST — 20 — B — P120 — FCCC

Product Family	LED Emission Area	Color	Package Configuration	Bin kit
SST: Surface Mount Package	20: 2.0 mm <sup>2</sup>	Color	P: Soldering pad configuration A type - see page 6 B type - see page 7	Flux and Chromaticity bin kit code as outlined above

## Optical and Electrical Characteristics<sup>1-3</sup>

### Optical and Electrical Characteristics at 350mA<sup>1</sup>

Parameter	Symbol	Minimum	Typical	Maximum	Unit
Forward Current at test <sup>2</sup>	$I_f$	350			mA
Output Radiometric Power	$\Phi_r$		710		mW
Forward Voltage	$V_f$	2.5	2.80	3.2	V
Wall-Plug Efficiency	WPE		72		%
Photosynthetic Photon Flux (PPF) <sup>4</sup>	$\mu\text{mol/s}$		2.68		
PPF Efficacy (PPF/W)	$\mu\text{mol/J}$		2.73		
Viewing Angle (A120 / B120)	$2 \text{ } \emptyset_{1/2}$		120		degrees
Peak Wavelength	$\lambda_p$	440	450	460	nm
FWHM	$\Delta\lambda_{1/2}$	20	22	24	nm
Forward Current (CW) <sup>2</sup>	$I_{fmin}, I_{fmax}$	0.2		3	A
Maximum Surge Current	$I_{fsmax}$			4	A
Maximum Reverse Current <sup>3</sup>	$I_{rev}$			N.A.	
LED Junction Temperature	$T_j$			150	°C
ESD withstand Voltage HBM Per JEDEC/ESDA STANDARD JS-001	$V_{HBM}$	8000			V
ESD withstand Voltage CDM Per JEDEC/ESDA STANDARD JS-002	$V_{CDM}$	1000			V
Operating Temperature	$T_{OPR}$	-40		80	°C
Storage Temperature	$T_{STG}$	-40		100	°C
Thermal resistance junction to case (electrical)	$R_{\theta_{JC-EL}}$		3.5		°C/W

Note 1: Ratings are based on operation at a constant junction temperature of  $T_j = 25^\circ\text{C}$ .

Note 2: Sustained operation at maximum current will result in shortened lifetime.

Note 3: Not designed for reverse voltage operation.

Note 4: Values at 350mA,  $T_j = 25^\circ\text{C}$  and computed in the 400nm to 700nm range.

## Optical and Electrical Characteristics

### Relative Output Flux vs. Forward Current

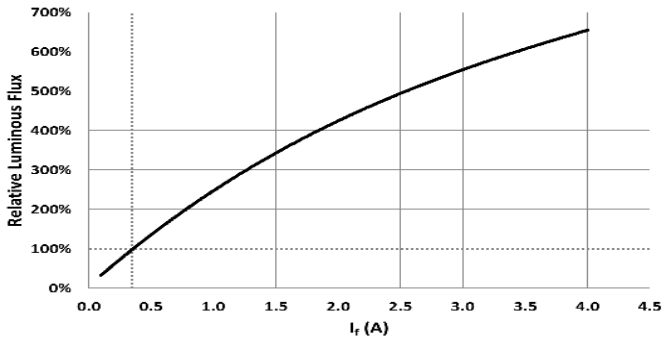

### Forward Voltage vs. Forward Current

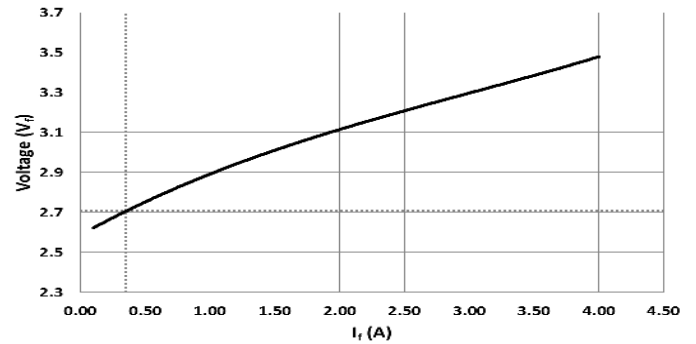

### Relative Output Flux vs. Junction Temperature

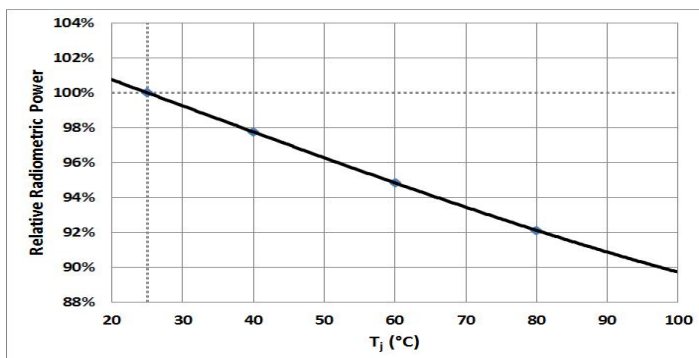

### Typical Spectra

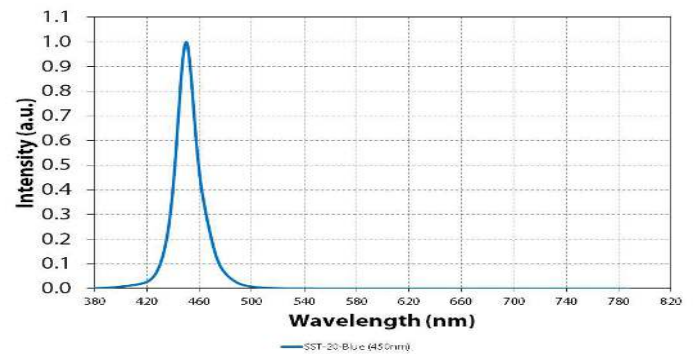

### Typical Angular Pattern of Radiant Power - Types A120 and B120<sup>4</sup>

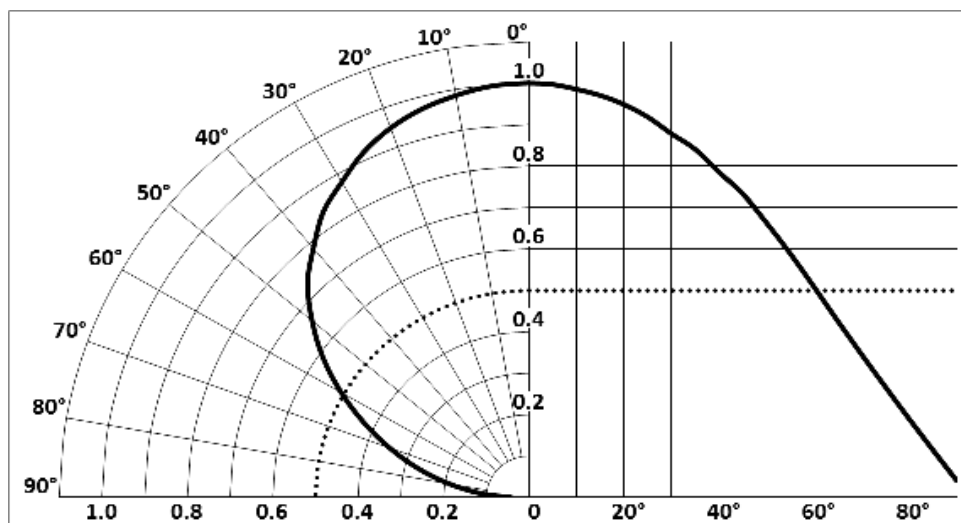

Note 4: Angular pattern measurements were made at 350mA, 25°C.

## Mechanical Dimensions<sup>5</sup>

### A120 Package Configuration

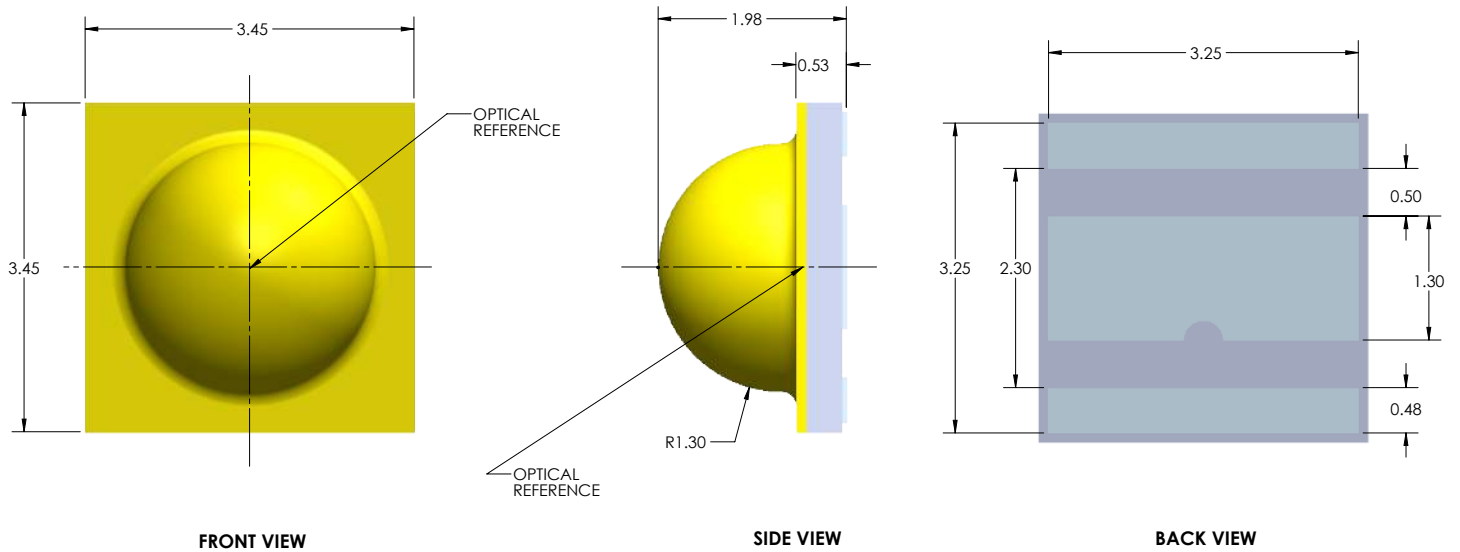

## Recommended PCB Solder Pad and Stencil Pattern<sup>5</sup>

### A120 Package Configuration

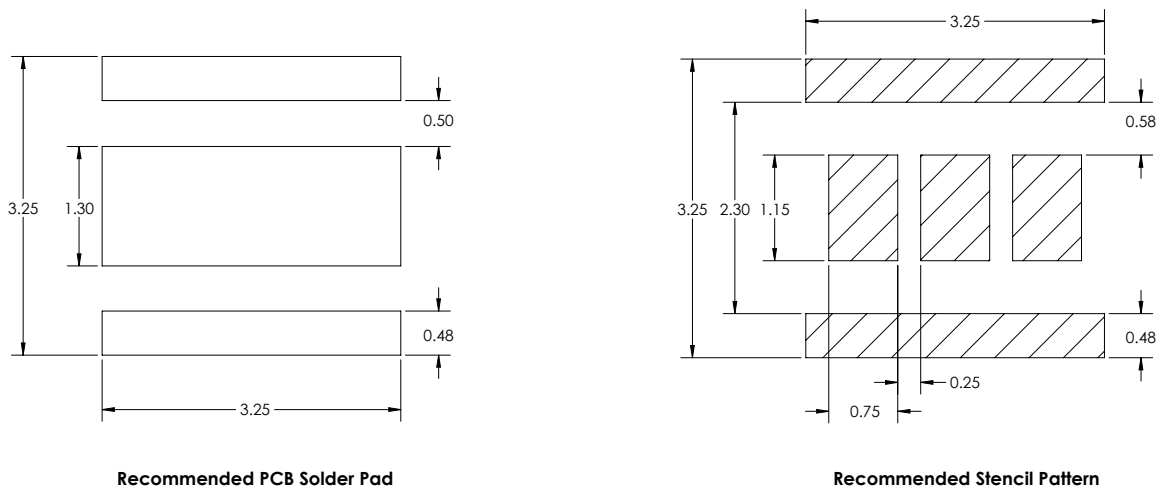

Note 5: Dimensions are in millimeters +/- 0.13 mm

## Mechanical Dimensions<sup>6</sup>

### B120 Package Configuration

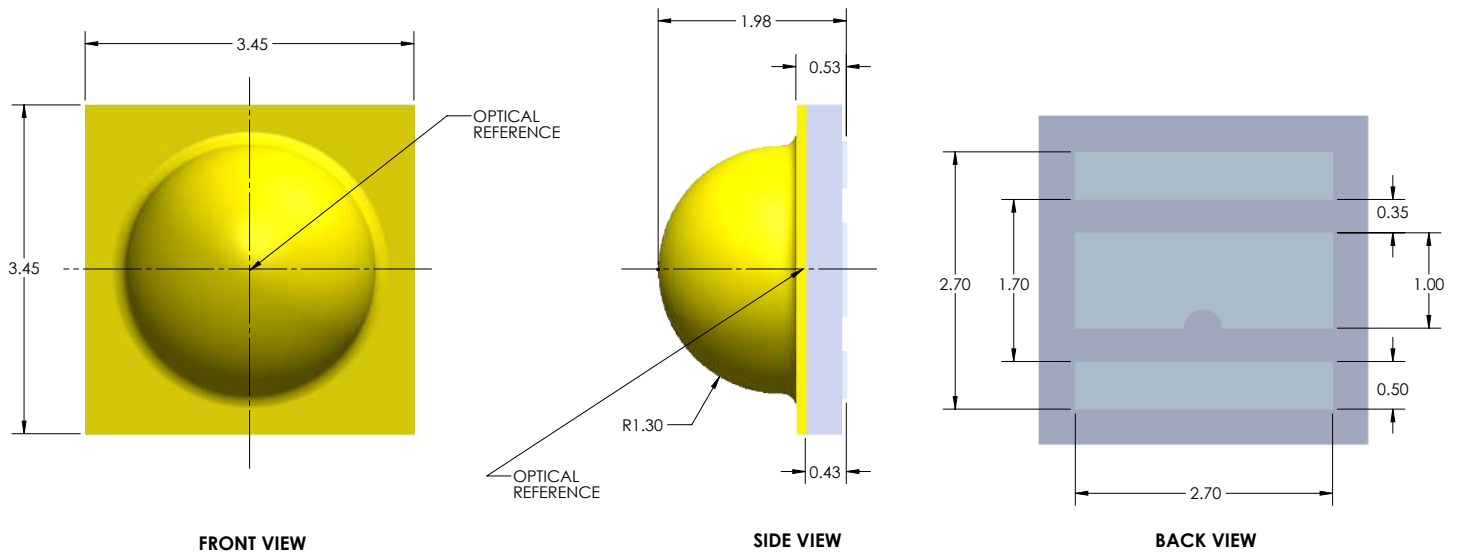

## Recommended PCB Solder Pad and Stencil Pattern<sup>6</sup>

### B120 Package Configuration

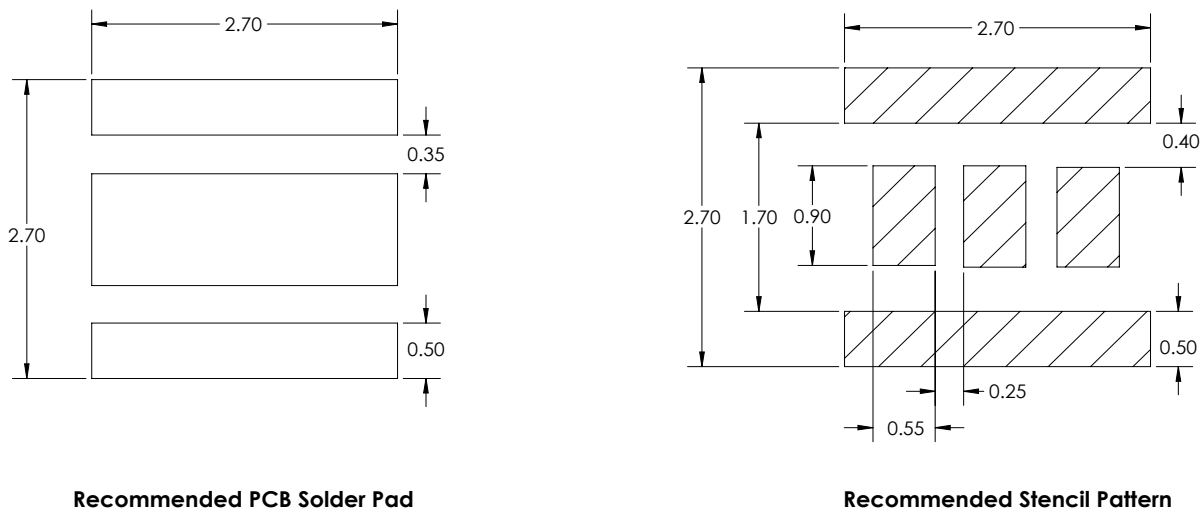

Note 6: Dimensions are in millimeters +/- 0.13 mm

**Tape and Reel - A120 and B120 Package Configurations<sup>7,8</sup>**

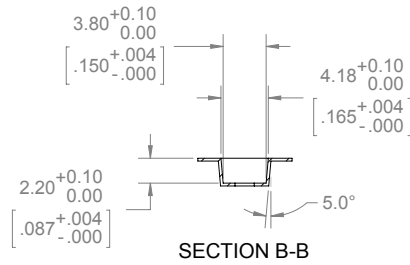
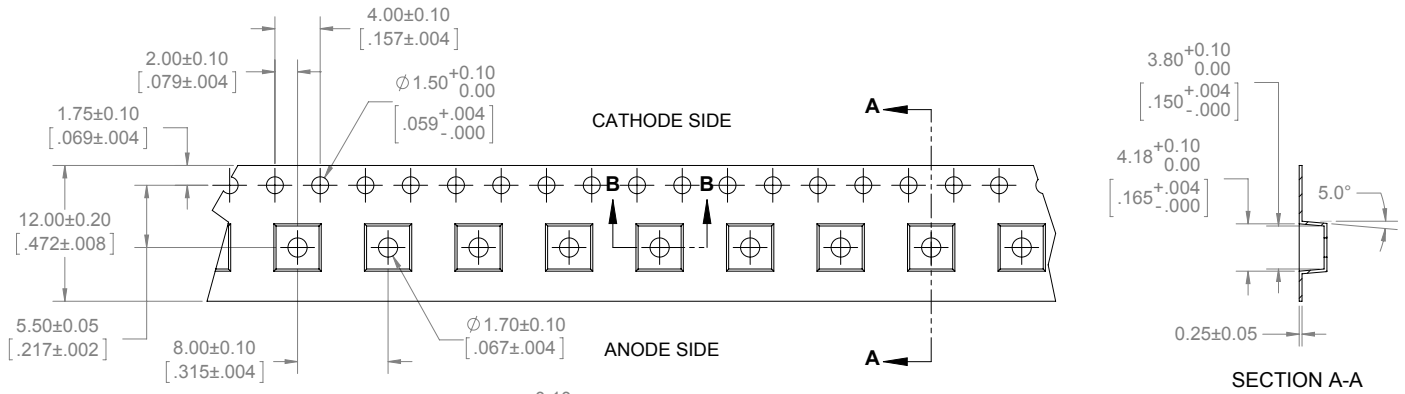

**NOTES:**

1. FINAL TAPE AND REEL PACKAGING MUST MEET THE REQUIREMENTS OF JEDEC-STD-033, LEVEL 2A.
2. LEAVE 304.8mm [12.00 in] OF TAPE EMPTY FOR LEAD IN (38 EMPTY POCKETS).
3. LEAVE 457.2mm [18.00 in] OF TAPE EMPTY FOR TRAILER (57 EMPTY POCKETS).
4. MUST COMPLY TO EIA-481-C-2003

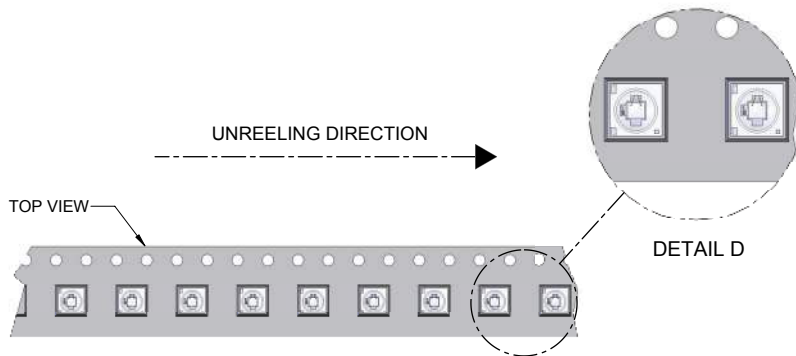
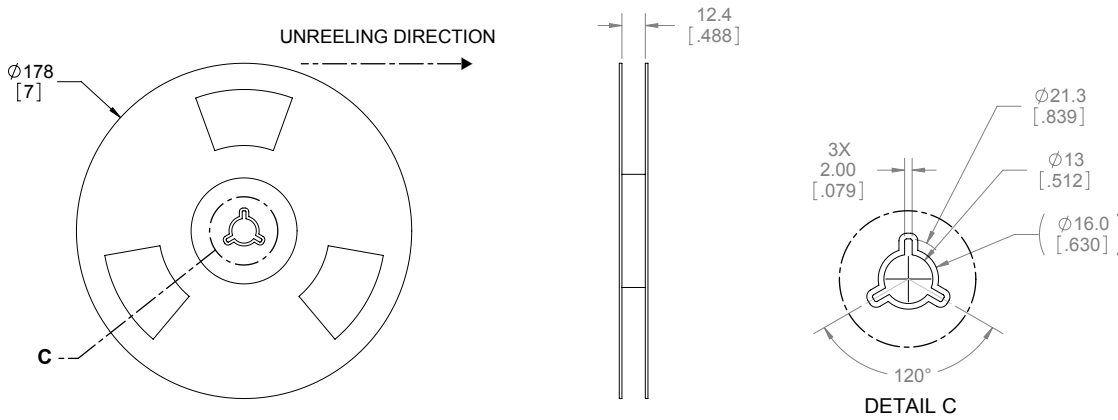

Note 7: Dimensions are in millimeters

Note 8: Quantity per reel: 1,000 pcs



### Reel Packaging

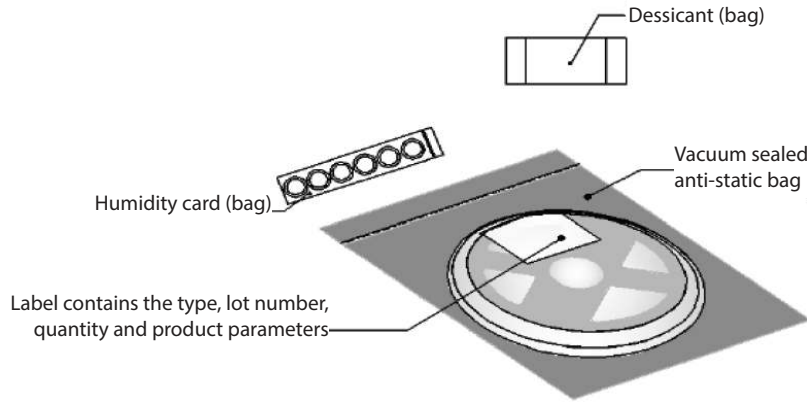

### Reel Label

Label Fields:

- CPN: Luminus ordering part number
- MPN: For Luminus internal use
- Qty on reel
- 2D Bar codes
- Flux: FF as defined on page 3
- Voltage: VV as defined on page 3
- Color: CC as defined on page 6
- Mfg Info: For Luminus internal use



**CPN:** SST-20-WCS-B120

**MPN:** xxxxxx

**QTY:** 1000 pcs



BIN INFO	
<b>Flux:</b>	K5
<b>Voltage:</b>	VJ
<b>Color:</b>	BC

MFG INFO
<b>Rev:</b> 01
<b>Lot#:</b> xxx-xxxxxxxxxx

RoHS Compliant

### Box Packaging Information

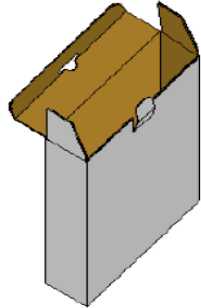

\*Capacity 5 reels per box

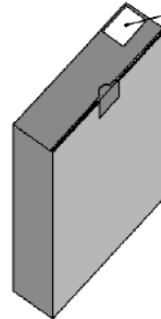

Label: contains the type,  
Lot #, Quality, Product  
parameters

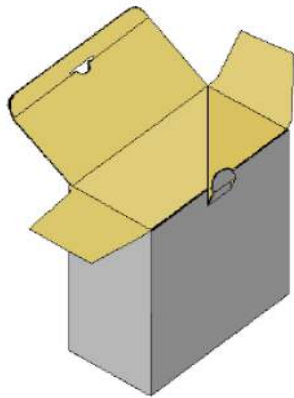

\*Capacity 10 reels per box

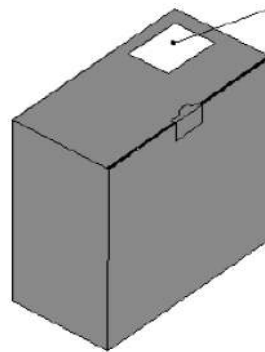

Label: contains the type, Lot  
#, Quality, Product  
parameters

### Soldering Profile

Profile Feature	Sn-Pb Eutectic Assembly	Pb-Free Assembly
Preheat & Soak	100 °C	150 °C
Temperature min (T <sub>smin</sub> )	150 °C	200 °C
Temperature max (T <sub>smax</sub> )	60-120 seconds	60-120 seconds
Time (T <sub>smin</sub> to T <sub>smax</sub> ) (t <sub>s</sub> )		
Average ramp-up rate (T <sub>smax</sub> to T <sub>p</sub> )	3 °C/second max	3 °C/second max
Liquidous temperature (T <sub>L</sub> )	183 °C	217 °C
Time at liquidous (t <sub>L</sub> )	60-150 seconds	60-150 seconds
Peak package body temperature (T <sub>p</sub> )*	230 °C ~235 °C	255 °C ~260 °C
Classification temperature (T <sub>c</sub> )	235 °C	260 °C
Time (t <sub>p</sub> ) within 5 °C of the specified classification temperature (T <sub>c</sub> )	20 seconds	30 seconds
Average ramp-down rate (T <sub>p</sub> to T <sub>smax</sub> )	6 °C/second max	6 °C/second max
Time 25 °C to peak temperature	6 minutes max	8 minutes max

\* Tolerance for peak profile temperature(T<sub>p</sub>) is defined as a supplier minimum and a user maximum.

\*\* Tolerance for time at peak profile temperature(t<sub>p</sub>) is defined as a supplier minimum and a user maximum.

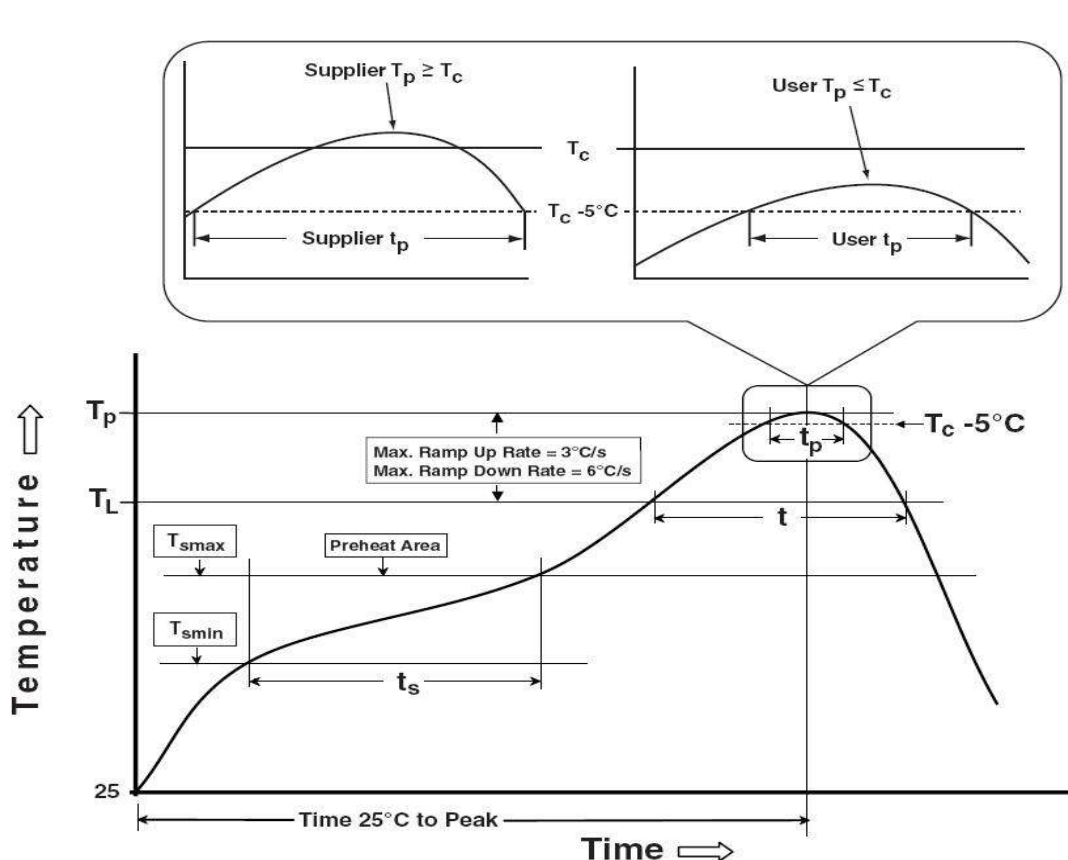

## Precautions for Use

### Storage:

#### 1. Before opening the package

The LEDs should be kept at a temperature lower than 40° C and relative humidity lower than 90%. The LEDs should be used within a year. When storing the LEDs, moisture proof package with absorbent material (silica gel) is recommended.

#### 2. After opening the package

The LEDs should be kept at temperature lower than 30° C and relative humidity lower than 60%. The LEDs should be soldered within 168 hours (7days) after opening the moisture proof package.

If unused LEDs remain, they should be stored in moisture proof packages, such as sealed containers with moisture proof package within absorbent material (silica gel). It is also recommended to return the unused LEDs to the original moisture proof package and to seal the moisture proof package again.

If the moisture absorbent material (silica gel) vapors or expires the expiration date, baking treatment should be performed by using the following conditions : 60 °C for 20 hours.

The LEDs electrode and leadframe comprise a silver plated copper alloy. The silver surface may be affected by environments. Please avoid conditions which may cause the LEDs to corrode or discolor. The corrosion or discoloration might lower solderability or affect optical characteristics.

Please avoid rapid transition in ambient temperature, especially in high humidity environments where condensation can occur.

### Static Electricity:

1. The products are sensitive to static electricity, and care should be taken when handling them.

2. Static electricity or surge voltage will damage the LEDs. It is recommended to wear a anti-electrostatic wristband or anti-electrostatic gloves when handling the LEDs.

3. All devices, equipment and machinery must be properly grounded. It is recommended that measures be taken against surge voltage to the equipment that mounts the LEDs.

### History of Changes

Rev		Description of Change
01	09/25/2017	Initial Release - Preliminary Specifications
02	07/07/2018	Update picture on front page. Remove preliminary wording. Add PPF & PPF/W values