

RECOMMENDED PCB LAYOUT

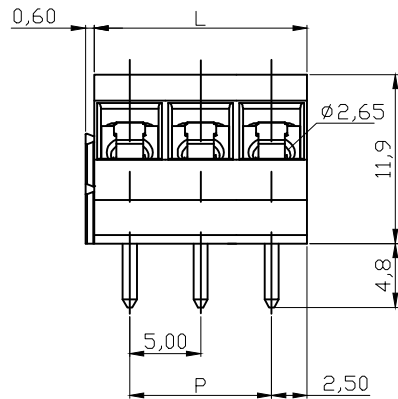

N=NUMBER OF CONTACTS

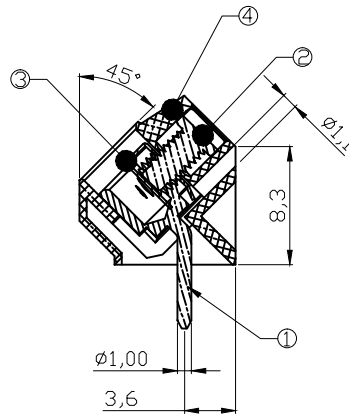

Material

- Item ① Terminal body(metal housing): Brass(CuZn),Tin plated
- Item ② Terminal screw: Steel Zinc plating "-" slot type
- Item ③ Wire guard: Stainless steel
- Item ④ Insulator (housing): Thermoplastic(UL94V-0),Black

Electrical

- Voltage rating: 300VAC
- Current rating: 15A
- Wire range:
- Solid wire(AWG): 14-22
- Stranded wire(AWG): 14-22
- Torque(Lb-In): 3.5
- Screw: M2.6
- Wire strip length: 6-7mm
- Withstanding Voltage: 1.6KV
- Operating temperature: -40°C to +115°C
- Soldering temperature: 250°C±10°C/5 Sec
- Safety Approval: us

N=Number of poles
 L=Nx5.0
 P=(N-1)x5.0

POLES	L	P
2p-6p	±0.20	±0.15
7p-12p	±0.25	±0.20
13p-18p	±0.30	±0.25
19p-24p	±0.40	±0.30

RoHS compliant

Unit: mm



File No.: E349947

Scale	1:1					Date	Name	Customer-No.	
TOLERANCE						Drawn	14.09.2007	Dean	
X.	±0.50					Approved	18.04.2016	Joanna	
X.X	±0.30	③	Add UL	18.04.2016	Joanna			ASSMANN WSW-No. A-TB500-VYxx	
X.XX	±0.10	②	Update	20.04.2010	Dean			Drawing-No.	
DIM	TOL	①	Drawn	14.09.2007	Hellwig			ASS 2336 CO	rev03
X.°	±1°							Replace	Sheet
Angle	TOL	ld.	Modification	Date	Name				