

GLOBAL PERFORMANCE SWITCHERS



Summary:

- Industry's smallest 20 W switcher
- Business-card size (2.0 x 3.5 x 0.71")
- Approved to UL60950, CSA-C22.2 No. 60950, EN60950, IEC60950 with CB Certificate
- EMI FCC Class B, CISPR22B
- Overvoltage protection standard
- RoHS compliant models available (G suffix)
- (C) marked to LVD



SPECIFICATIONS

Ac Input 90-264 Vac, 47-63 Hz single phase.
Input Current Maximum input current at minimum 120 Vac, 60 Hz with full rated output load is 0.6 A.
Hold-up Time 15 ms minimum from loss of ac input at full load, nominal line (115 Vac).
Output Power Normal continuous output power is 20 W, 24 W peak for 60 s maximum duration, 10% duty cycle. Factory set to begin power limiting at approximately 28 W.
Output Regulation Regulation from initial setpoint measured by changing load from 5% load to 50% load or 50% load to full load in either direction. Initial setpoint tolerance is measured at 50% load. A minimum load of 5% of the output current is required to maintain proper regulation.
Overload Protection Fully protected against short circuit and output overload. Short circuit protection is cycling type power limit
Output Noise 0.5% rms, 1% pk-pk, 20 MHz bandwidth, differential mode. Measured with scope probe directly across output terminals of the power supply with load terminated with 0.1 uF capacitor.
Transient Response Main output: 750 μs typical response time for return to within 0.5% of final value for a 50% load step within the regulation limits of minimum and maximum load, ΔI/Δt <0.2 A/μs Maximum voltage deviation is 3.5%. Startup/shutdown overshoot less than 2%.
Overvoltage Protection Built in with firing point set per ratings table. OVP firing reduces voltage to less than 50% of nominal voltage in 50 ms.
Turn-on time Less than 1 second at 115 Vac, 25o C (inversely proportionate to input voltage and thermistor temperature.

Efficiency 70% minimum at full rated load, nominal input voltage. Efficiency increases as output voltage increases.												
Input Protection Internal ac fuse provided on all units. Inrush Current												
Inrush is limited by internal thermistor. The inrush at 230 Vac, averaged over the first ac half-cycle under cold start conditions will not exceed 32 A.												
Temperature Coefficient 0.03%/°C typical on all outputs.												
Environmental Designed for 0 to 50°C operation at full rated output power; derate output current and total output power by 2.5% per °C above 50°C. See Environmental Specifications on next page.												
EMI/EMC Compliance All models include built-in EMI filtering to meet the following emissions requirements:												
<table border="1"> <thead> <tr> <th>EMI SPECIFICATIONS</th> <th>COMPLIANCE LEVEL</th> </tr> </thead> <tbody> <tr> <td>Conducted Emissions</td> <td>EN55022 Class B; FCC Class B</td> </tr> <tr> <td>Static Discharge</td> <td>EN61000-4-2, 6 kV contact, 8 kV air</td> </tr> <tr> <td>RF Field Susceptibility</td> <td>EN61000-4-3, 3 V/meter</td> </tr> <tr> <td>Fast Transients/Bursts</td> <td>EN61000-4-4, 2 kV, 5 kHz</td> </tr> <tr> <td>Surge Susceptibility</td> <td>EN61000-4-5, 1 kV diff., 2 kV com.</td> </tr> </tbody> </table>	EMI SPECIFICATIONS	COMPLIANCE LEVEL	Conducted Emissions	EN55022 Class B; FCC Class B	Static Discharge	EN61000-4-2, 6 kV contact, 8 kV air	RF Field Susceptibility	EN61000-4-3, 3 V/meter	Fast Transients/Bursts	EN61000-4-4, 2 kV, 5 kHz	Surge Susceptibility	EN61000-4-5, 1 kV diff., 2 kV com.
EMI SPECIFICATIONS	COMPLIANCE LEVEL											
Conducted Emissions	EN55022 Class B; FCC Class B											
Static Discharge	EN61000-4-2, 6 kV contact, 8 kV air											
RF Field Susceptibility	EN61000-4-3, 3 V/meter											
Fast Transients/Bursts	EN61000-4-4, 2 kV, 5 kHz											
Surge Susceptibility	EN61000-4-5, 1 kV diff., 2 kV com.											
Commercial Safety Condor D.C. Power Supplies, Inc. declares under our sole responsibility that all GSC models are in conformity with the applicable requirements of EN60950 following the provisions of the Low Voltage Directive 73/23/EEC. All GSC models are approved to UL60950, CSA-C22.2 No. 60950, EN60950, IEC60950 with CB Certificate.												

Commercial Model	Output	Current	Load Regulation	Initial Setpoint Tolerance	OVP Setpoint	Ripple and Noise
GSC20-5	5.1 V	3.8 A	0.75%	2.5%	6.2 ± 0.6 V	1.4%
GSC20-12	12 V	1.7 A	0.75%	2.5%	14 ± 1.1 V	1%
GSC20-15	15 V	1.4 A	0.75%	2.5%	18.5 ± 1.5 V	1%
GSC20-24	24 V	0.85 A	0.75%	2.5%	28 ± 2.5 V	1%
GSC20-28	28 V	0.7 A	0.75%	2.5%	34 ± 2.8 V	1%

* Add G suffix to model number for RoHS compliant model.

GSC20 MECHANICAL SPECIFICATIONS

INPUT J1 MOLEX P/N 22-43-8040

PIN 1) AC LINE
PIN 2) N/C
PIN 3) N/C
PIN 4) AC NEUTRAL

GND: 0.098 DIA. THRU HOLE

OUTPUT J2 MOLEX P/N 22-43-8040

PIN 1) OUTPUT #1
PIN 2) OUTPUT #1
PIN 3) COMMON
PIN 4) COMMON

MATING CONNECTOR MOLEX P/N

HOUSING 50-37-5043
CONTACT 08-70-1040

NOTE: 3A MAXIMUM RECOMMENDED CURRENT
PER CONNECTOR PIN

WEIGHT 0.25 LB. [0.113 KG] MAX.

TOLERANCES:
X.XX ± 0.030 (0.76MM)
X.XXX ± 0.010 (0.25MM)

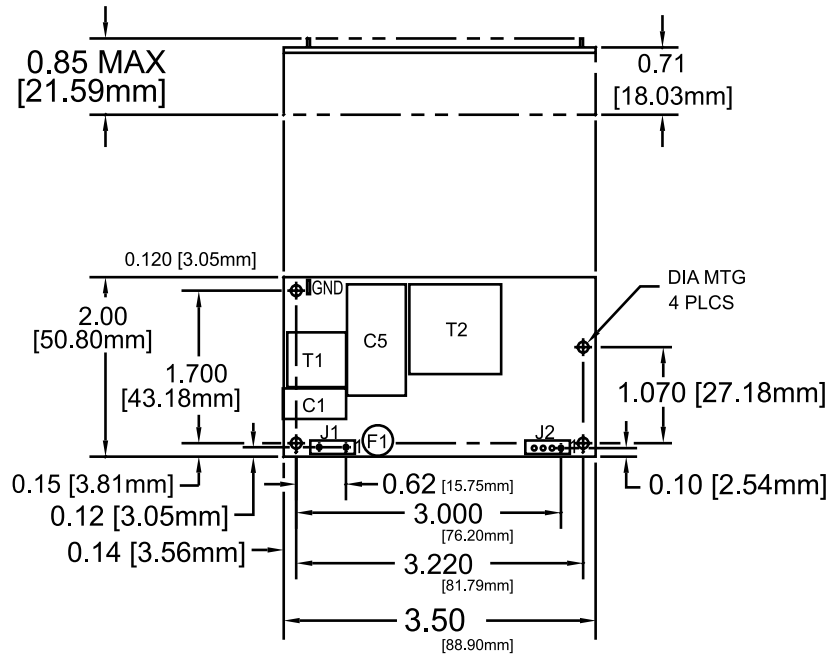

ENVIRONMENTAL SPECIFICATIONS	OPERATING	NON-OPERATING
Temperature (A)	See Individual Specs.	-40 to +85°C
Humidity (A)	0 to 95% RH	0 to 95% RH
Shock (B)	20 g _{pk}	40 g _{pk}
Altitude	-500 to 10,000 ft	-500 to 40,000 ft
Vibration (C)	1.5 g _{rms} 0.003 g ² /Hz	5 g _{rms} 0.026 g ² /Hz

- Units should be allowed to warm up/operate under non-condensing conditions before application of power.
- Random vibration—10 to 2000Hz, 6dB/octave roll-off from 350 to 2000Hz, 3 orthogonal axes. Tested for 10 min./axis operating and 1 hr./axis non-operating.
- Shock testing—half-sinusoidal, 10 ± 3 ms duration, ± direction, 3 orthogonal axes, total 6 shocks.