

LOC	DIST	REV	DATE	BY	APPD
CM	00	L2	04JUN2009	HMR	KR
REVISIONS			DESCRIPTION	DATE	DWN
			REVISED PER ECR-09-012310	04JUN2009	HMR

- 1 MATERIAL: NYLON, UL94V-2 (NATURAL).
- 2 MARKING FOR UL AND CSA LOGO SHALL BE LOCATED ON ANY EXTERNAL SURFACE.
- 3 AMP LOGO AND CIRCUIT NUMBERS LOCATED IN AREA, EITHER SIDE, SIZE OPTIONAL, FROST BACKGROUND.
- 4 WALL THICKNESS TO MEASURE 0.36-0.46 [.014-.018]
- 5 MATERIAL: NYLON 4/6, NATURAL.
- 6 PRELIMINARY - NOT FOR PRODUCTION.

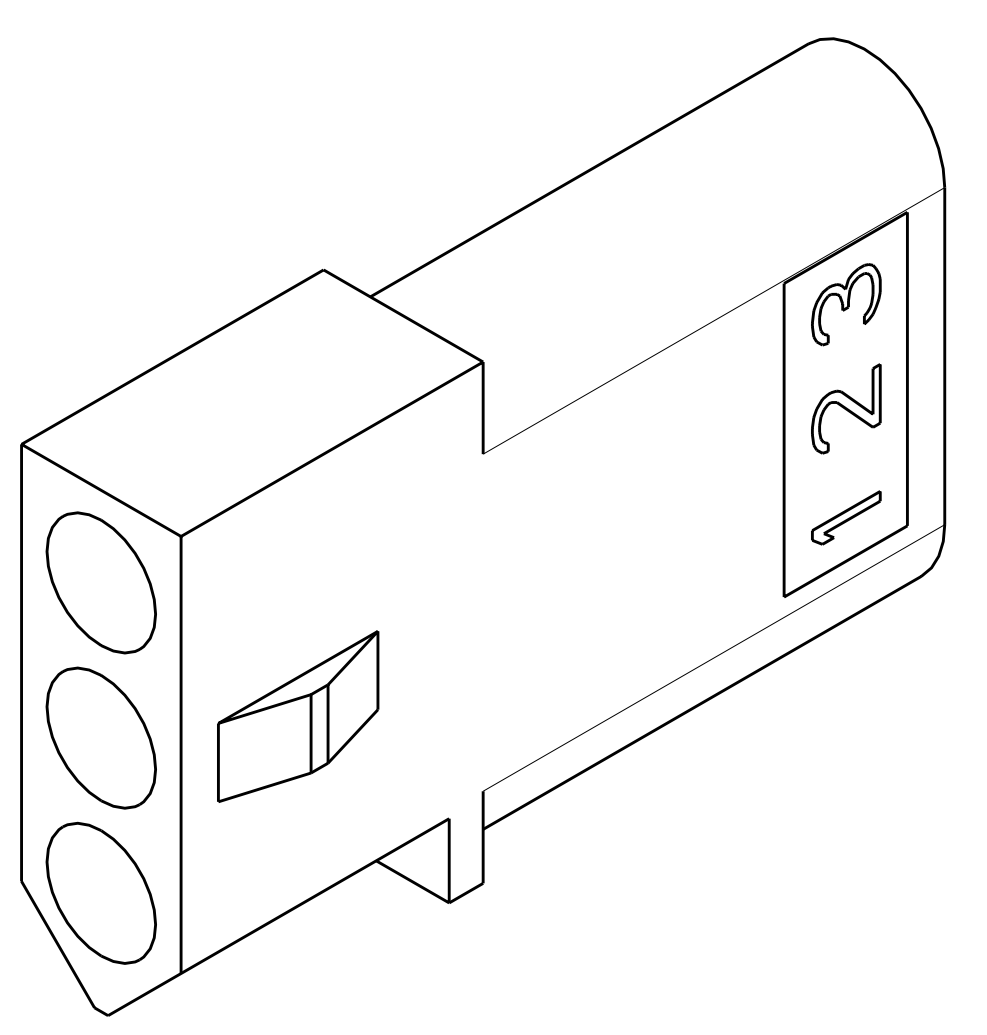
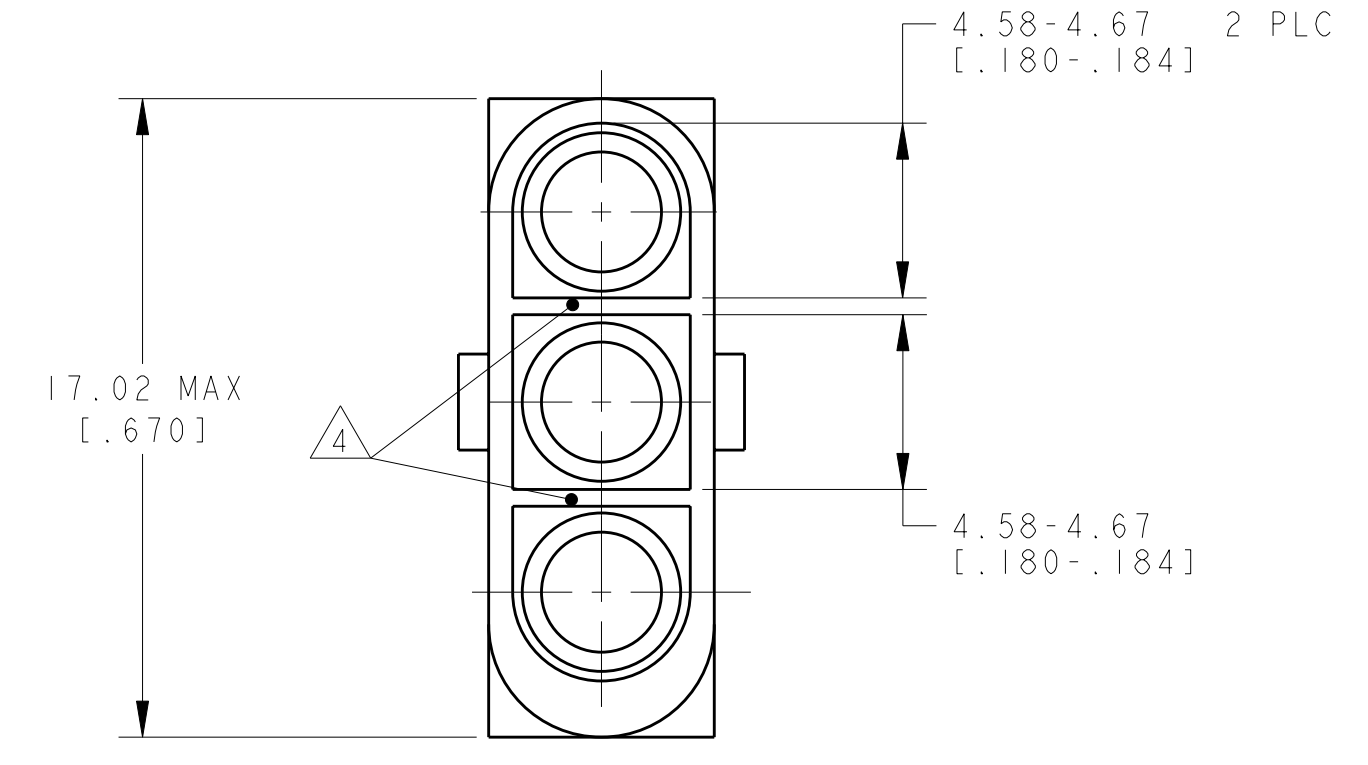
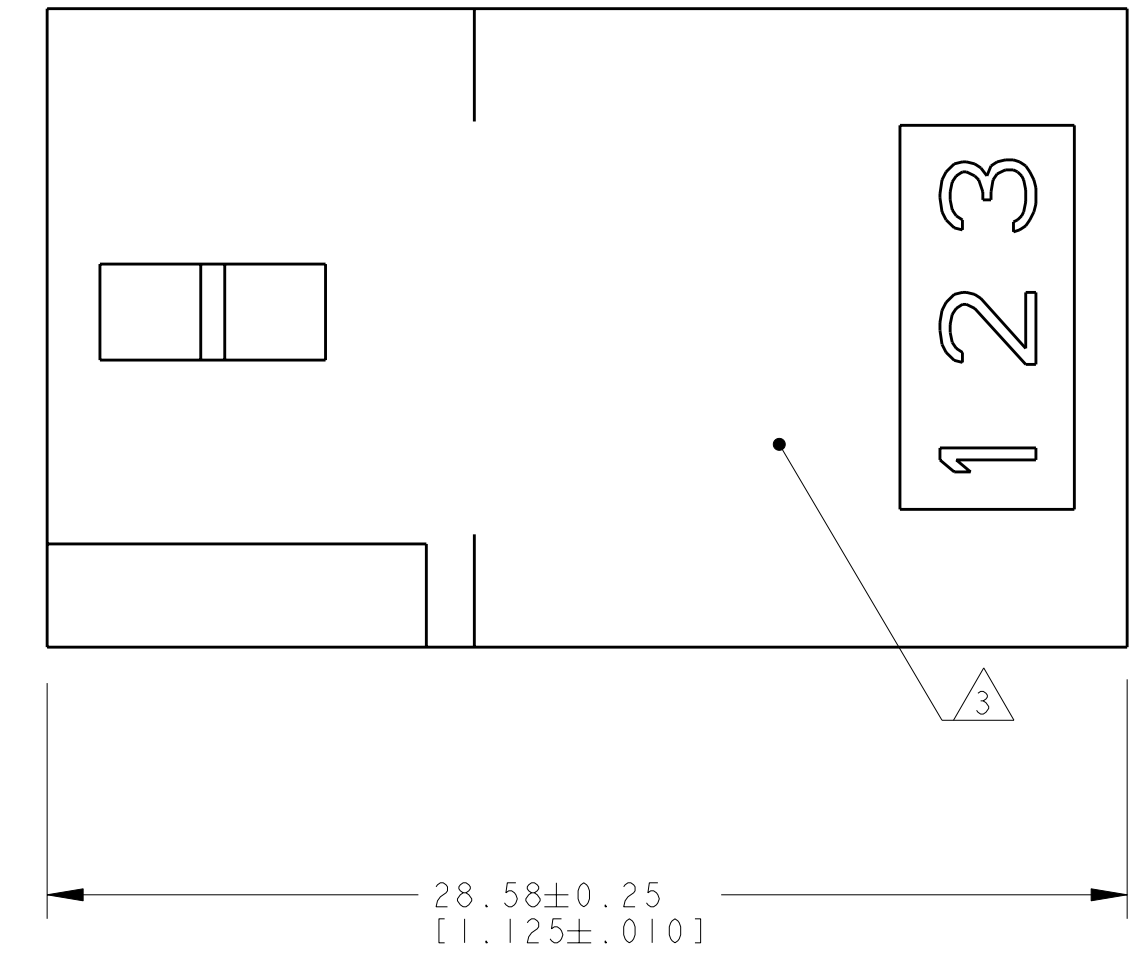
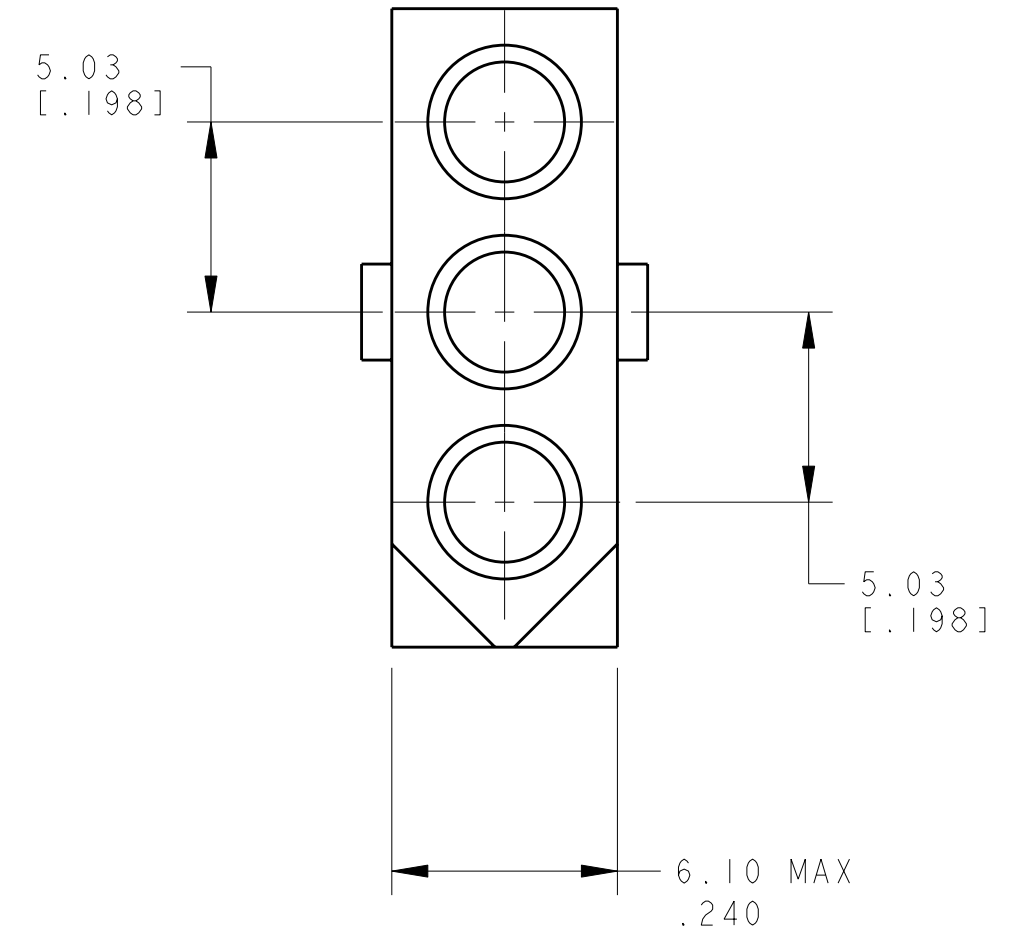

5	770070-2
4	770070-1
MATERIAL	PART NUMBER

DIMENSIONS: mm [INCHES]		TOLERANCES UNLESS OTHERWISE SPECIFIED: 0 PLC ± 1 PLC ± 2 PLC ±0.13 (1.005) 3 PLC ± 4 PLC ± ANGLES ±0°30'		DWN R. WHITAKER 03AUG2004 CHK D. COLEY 03AUG2004 APVD D. COLEY 03AUG2004		Tyco Electronics Harrisburg, PA 17105-3608	
MATERIAL SEE TABLE		FINISH -		NAME RECEPTACLE, 3 CIRCUIT, .093 COMMERCIAL PIN AND SOCKET		SIZE CAGE CODE DRAWING NO RESTRICTED TO A 100779 C-770070	
CUSTOMER DRAWING				SCALE 5:1		SHEET 1 OF 1 REV L2	

**METRIC**