

REVISIONS					
P	LTR	DESCRIPTION	DATE	DMN	APVD
D3	ECC-18-014918		21AUG2019	RR	SH

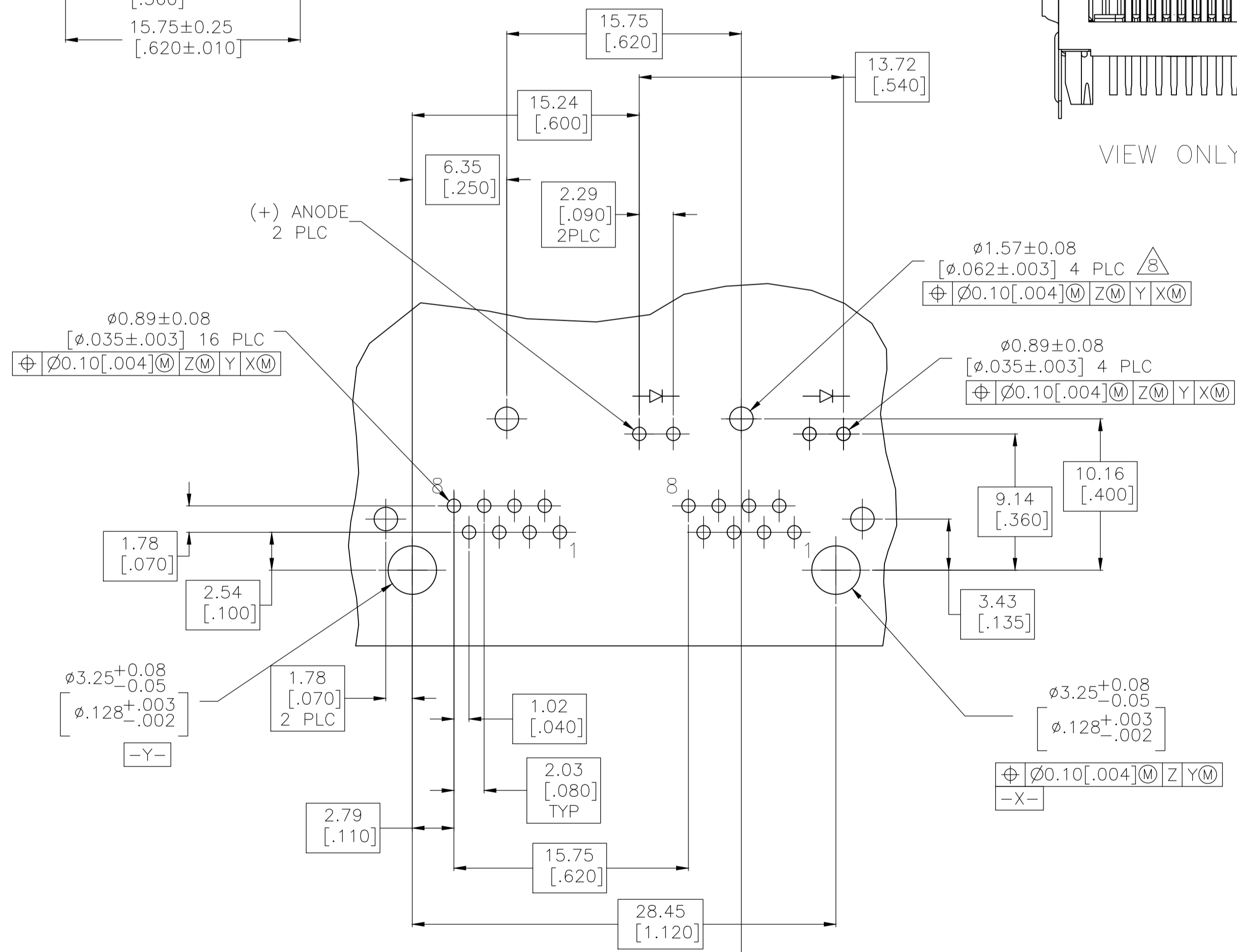
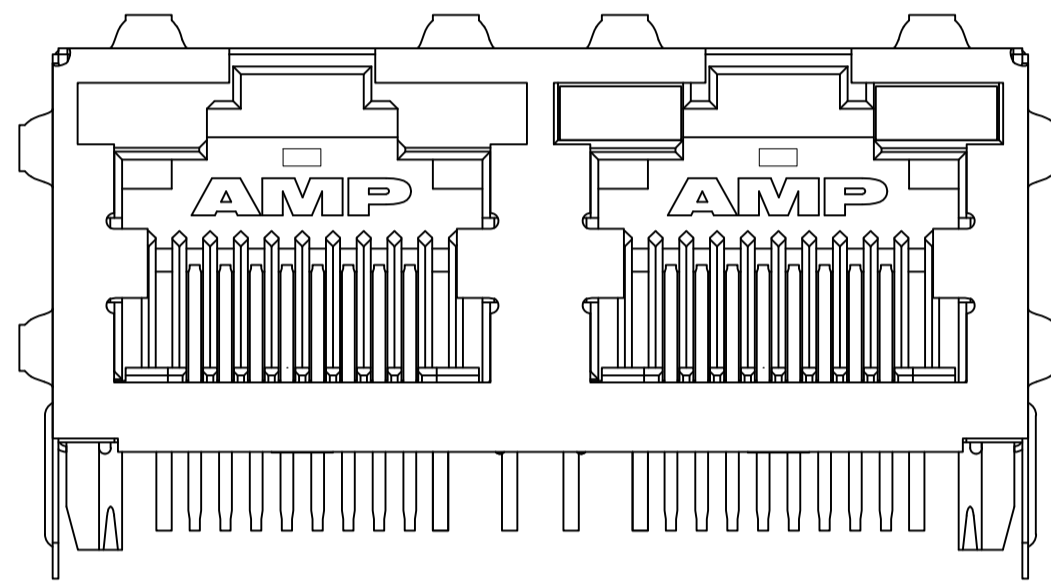
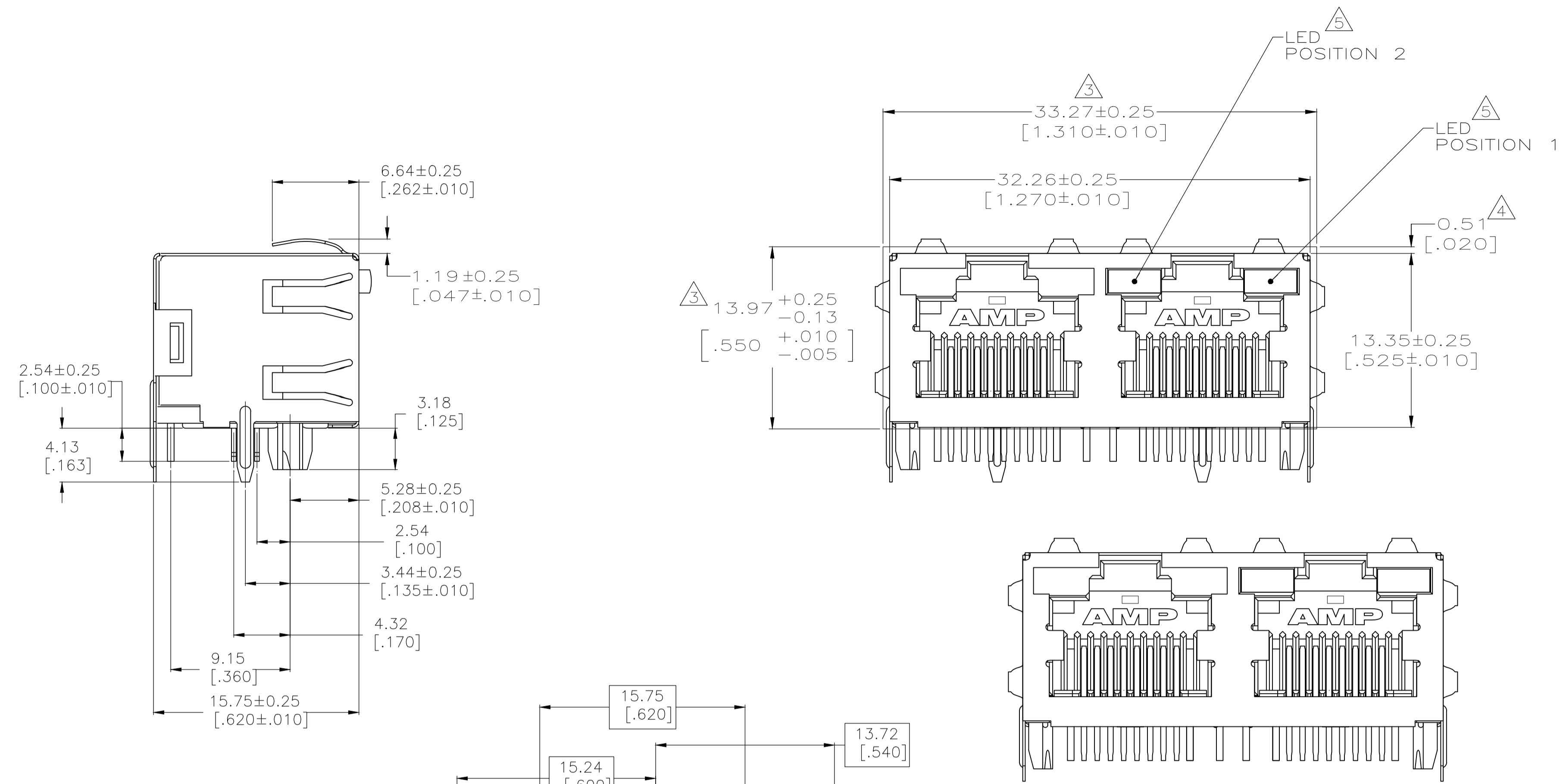

RECOMMENDED PRINTED CIRCUIT BOARD LAYOUT COMPONENT SIDE

△ MATERIAL:  
HOUSING - HIGH TEMPERATURE THERMOPLASTIC, COLOR: BLACK, UL94V-0  
TERMINALS - 0.36[.014] THICK PHOS BRONZE PLATED WITH 3.81µm[.000150] MIN THICK BRIGHT TIN LEAD IN SOLDER AREA, 1.27µm[.000050] MIN GOLD IN LOCALIZED PLATE AREA. ENTIRE TERMINAL PLATED WITH 1.27µm[.000050] MIN THICK NICKEL.  
SHIELD - 0.196[.0077] THICK COPPER ZINC ALLOY PREPLATED WITH 1.27µm[.000050] MIN SATIN NICKEL WITH 2.03µm[.000080] MIN TIN POST DIPPED ON PCB GROUND TABS  
LIGHT EMITTING DIODE (LED) - DIFFUSED EPOXY LENS, 0.51 X 0.51[.020 X .020] CARBON STEEL WIREFRAME LEADS PLATED WITH 8.89µm[.000350] TIN/COPPER OVER 2.03µm[.000080] SILVER OVER 1.02µm[.000040] NICKEL UNDERPLATE OVER 2.03µm[.000080] COPPER UNDERPLATE

- 2. JACK CAVITY CONFORMS TO FCC RULES AND REGULATIONS PART 68, SUBPART F.
- △ SUGGESTED PANEL OPENING DIMENSIONS.
- △ SUGGESTED CLEARANCE BETWEEN TOP OF CONNECTOR AND TOP PANEL OPENING.
- △ SEE TABLE FOR COLOR OF LEDS AND NUMBER REQUIRED.
- 6. THIS MODULAR JACK WITH INTEGRATED LED IS NOT IR REFLOW SOLDERING PROCESS COMPATIBLE.

△ MATERIAL:  
HOUSING - HIGH TEMPERATURE THERMOPLASTIC, COLOR: BLACK, UL94V-0  
TERMINALS - 0.36[.014] THICK PHOS BRONZE PLATED WITH 3.81µm[.000150] MIN THICK TIN IN SOLDER AREA, 1.27µm[.000050] MIN GOLD IN LOCALIZED PLATE AREA. ENTIRE TERMINAL PLATED WITH 1.27µm[.000050] MIN THICK NICKEL.  
SHIELD - 0.196[.0077] THICK COPPER ZINC ALLOY PREPLATED WITH 1.27µm[.000050] MIN SATIN NICKEL WITH 2.03µm[.000080] MIN TIN POST DIPPED ON PCB GROUND TABS  
LIGHT EMITTING DIODE (LED) - DIFFUSED EPOXY LENS, 0.51 X 0.51[.020 X .020] CARBON STEEL WIREFRAME LEADS PLATED WITH 8.89µm[.000350] TIN/COPPER OVER 2.03µm[.000080] SILVER OVER 1.02µm[.000040] NICKEL UNDERPLATE OVER 2.03µm[.000080] COPPER UNDERPLATE

- △ HOLES ON PCB FOR PCB GROUND TABS ACCORD TO CERTAIN PN.
- △ 1761791-5 HAS NO PCB GROUND TABS ON ITS REAR, HOLES ON PCB FOR THESE TABS ARE OPTIONAL.

INDICATOR COLOR FOR EACH HOUSING	POSITION 2	POSITION 1	PART NUMBER
OBSOLETE	GREEN	GREEN	△ 1761791-5
OBSOLETE	GREEN	GREEN	△ 1761791-4
OBSOLETE	YELLOW	GREEN	△ 1761791-3
OBSOLETE	GREEN	GREEN	△ 1761791-2
OBSOLETE	YELLOW	GREEN	△ 1761791-1

THIS DRAWING IS A CONTROLLED DOCUMENT. DIMENSIONS: mm [INCHES]. TOLERANCES UNLESS OTHERWISE SPECIFIED: 0 PLC ±, 1 PLC ±, 2 PLC ± 0.25[.01], 3 PLC ± 0.13[.005], 4 PLC ±, ANGLES ±.

DIN: RG/LA.MAYER 110CT2007. CJK: -. APVD: -. NAME: INVERTED MOD JACK ASSEMBLY, 1X2, SHIELDED, PANEL GROUND, LED. PRODUCT SPEC: 108-1163-4. APPLICATION SPEC: 114-2154. WEIGHT: 0.000000. SIZE: A1. CAGE CODE: 00779. DRAWING NO: 1761791. RESTRICTED TO: -. CUSTOMER DRAWING. SCALE: 4:1. SHEET: 1 OF 1. REV: D3.

**STE** TE Connectivity