

PRODUCT NO.
SEE TABLE

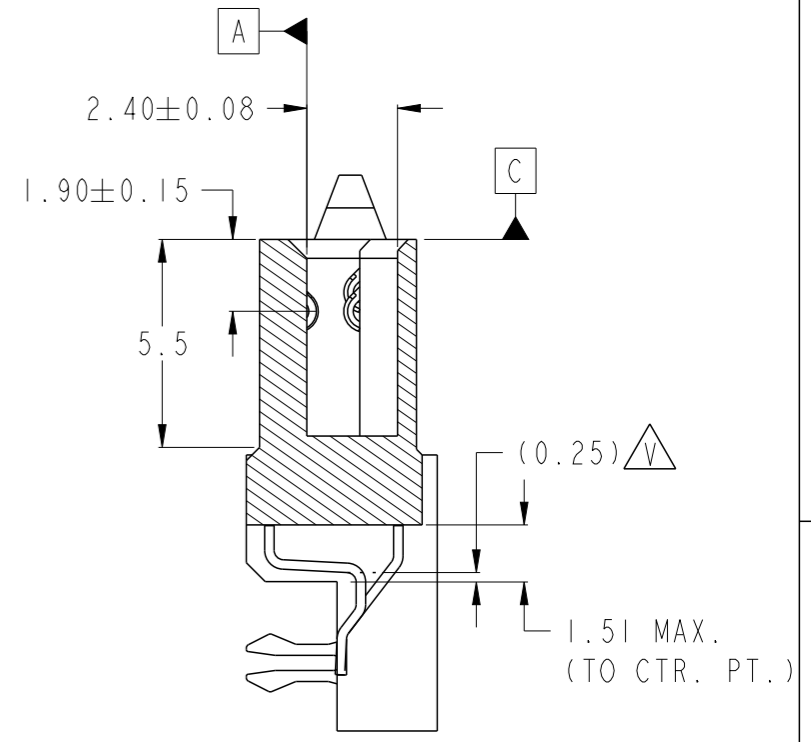

SECTION Y-Y
SCALE 5:1

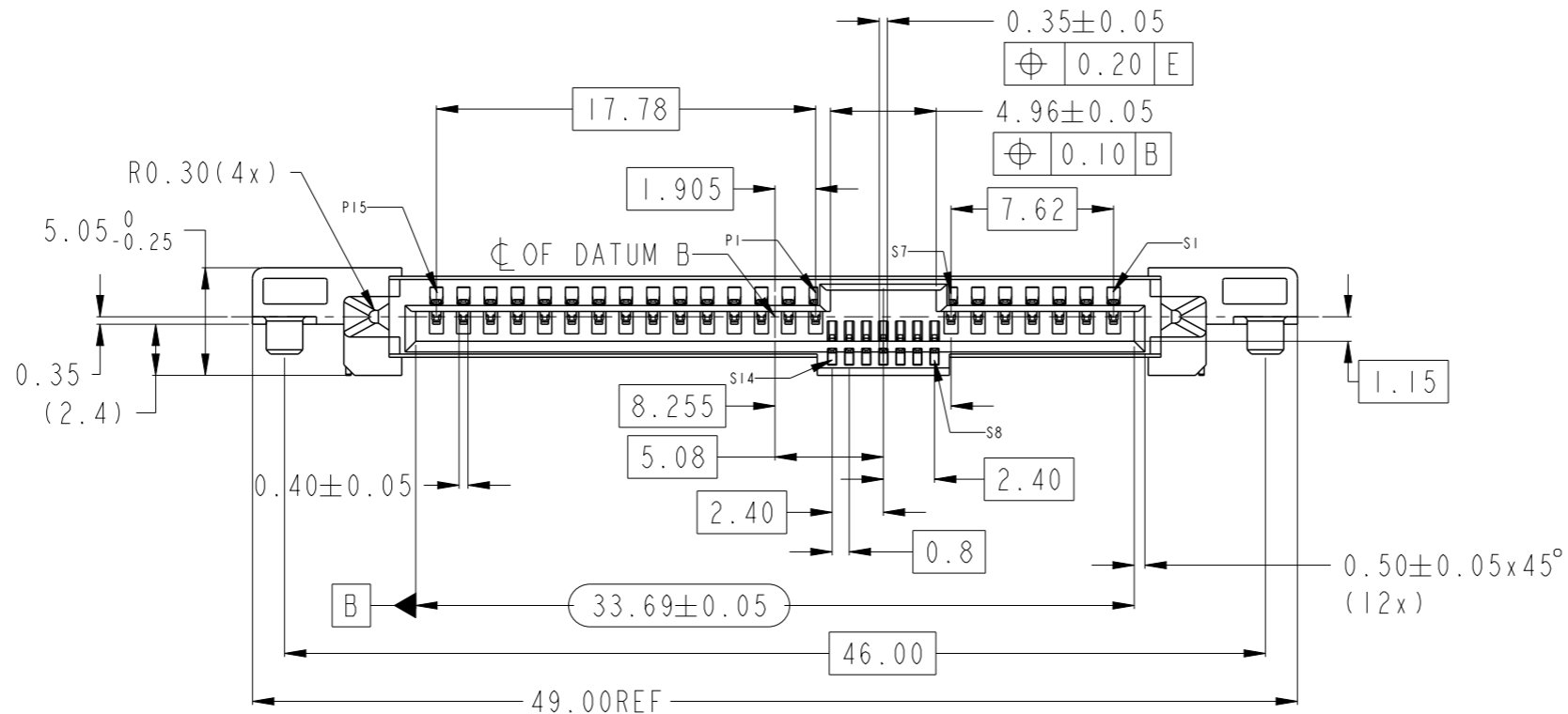
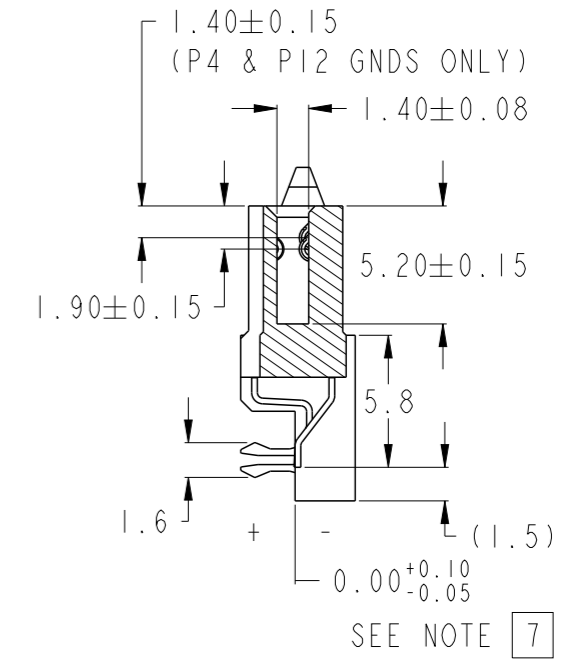
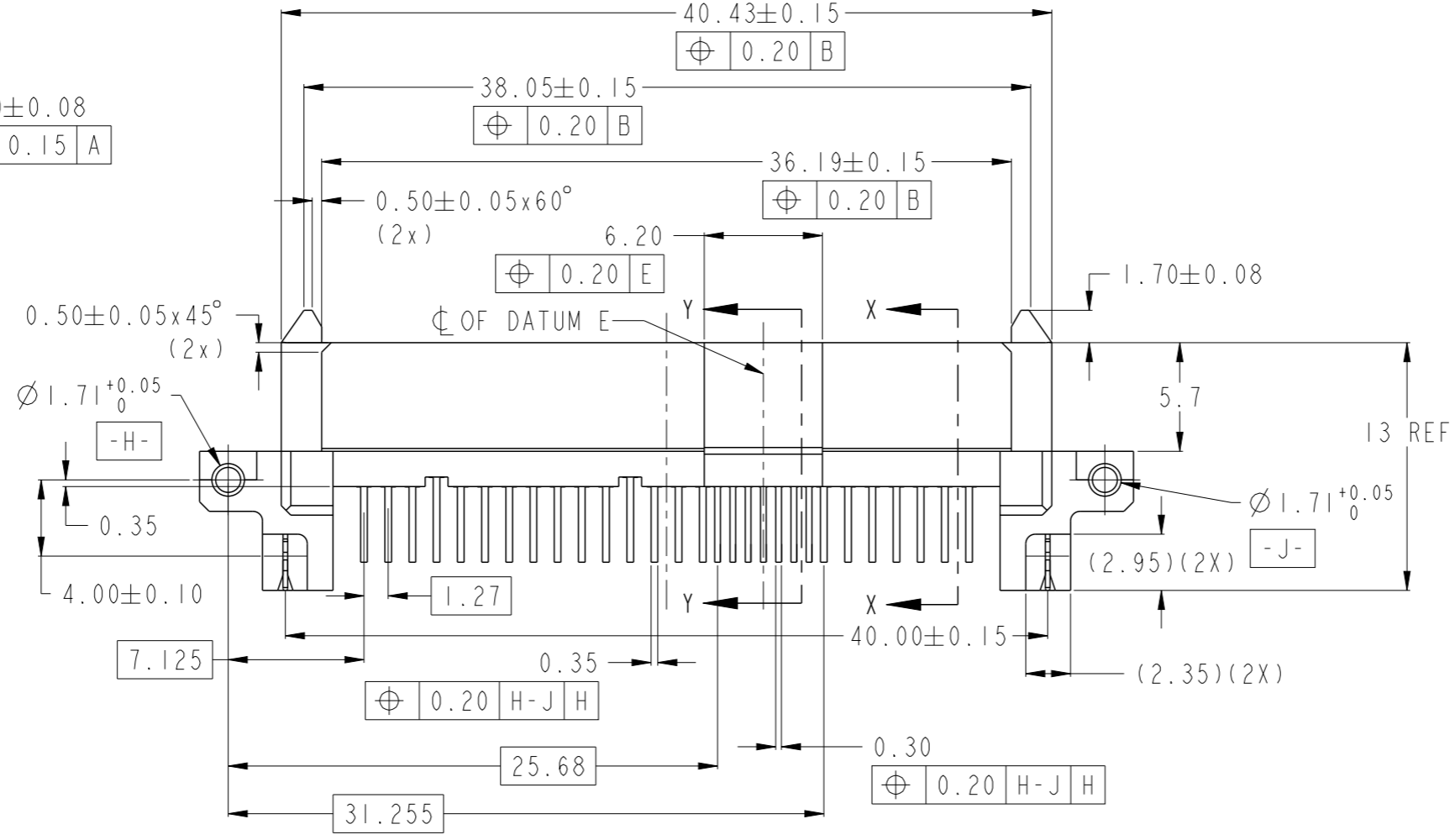
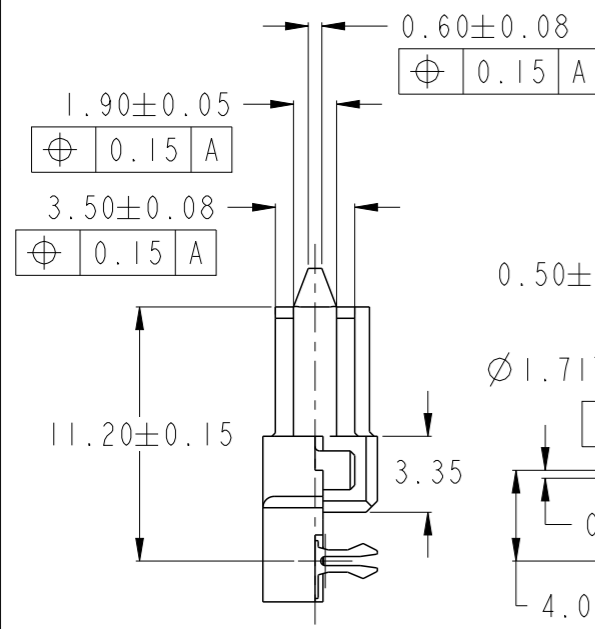

SECTION X-X
SEE NOTE 7

Amphenol FCI
© 2016 AFCI

spec ref	dr	wcadmin	2006/03/10	projection	MM	size	A3	scale	2:1
tolerance std	eng	Jeffrey Lim	2017/07/11			ecn no	ELX-S-27425-1		
ASME Y14.5	chr	-	rel level			Released			
TOLERANCES UNLESS OTHERWISE SPECIFIED	appr	Koon-Poh Tay	2017/07/28	product family	SAS RECEPTACLE		dwg no	10035202	rev
surface	linear	0.X	±	R/A SMT ASSY, Z-HT. 0.35		cat. no.	Product - Customer Drw	sheet 1 of 4	V
		0.XX	±0.2						
		0.XXX	±						
	angular	0°	±2°						

PRODUCT NO.	PIN S1-S7 & P1-P15	PIN S8-S14	HOLD DOWN	PICK-UP TAPE	PACKAGING
10035202-001LF	YES	YES	METAL CLIP	NO	TRAY
10035202-001TRLF					TAPE & REEL
10035202-002LF	YES	YES	BLADE	NO	TRAY
10035202-002TRLF					TAPE & REEL
10035202-002C-TRLF					TAPE & REEL

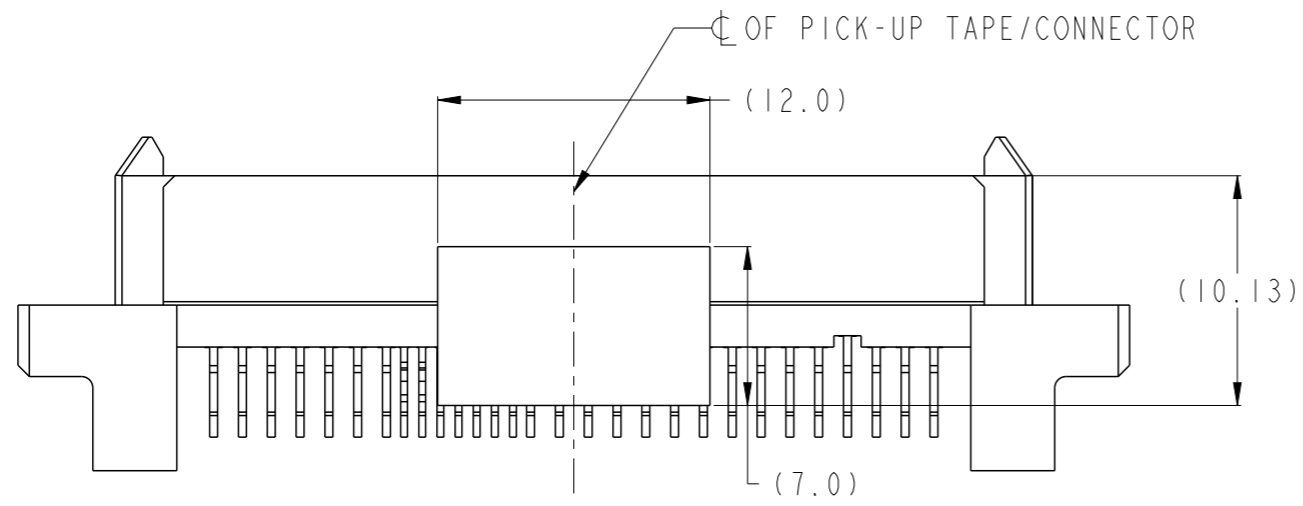

SCALE 3:1

10035202-001LF
10035202-001TRLF

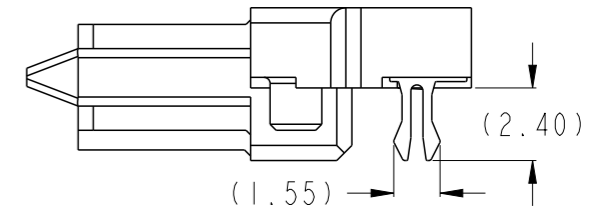

10035202-002LF
10035202-002TRLF

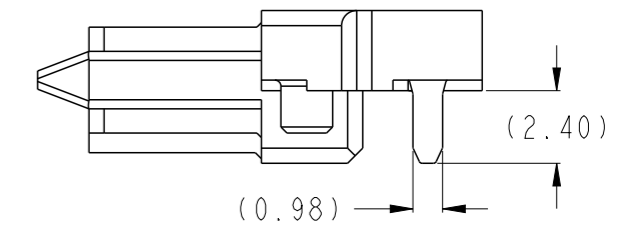

10035202-002C-TRLF

PICK-UP TAPE
(KAPTON)

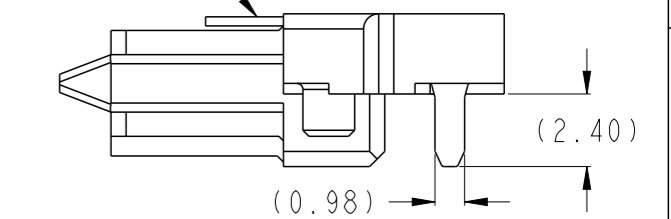

spec ref	dr	wcadmin	2006/03/10	projection	MM	size	A3	scale	2:1
tolerance std	eng	Jeffrey Lim	2017/07/11			ecn no	ELX-S-27425-1	rel level	Released
ASME Y14.5	chr	-	-						
surface	linear	0.X	±-	Amphenol FCI	SAS RECEPTACLE R/A SMT ASSY, Z-HT. 0.35	dwg no	10035202	rev	V
		0.XX	±0.2						
		0.XXX	±-						
	angular	0°	±2°	cat. no.	Product - Customer Drw	sheet 2 of 4			

A

B

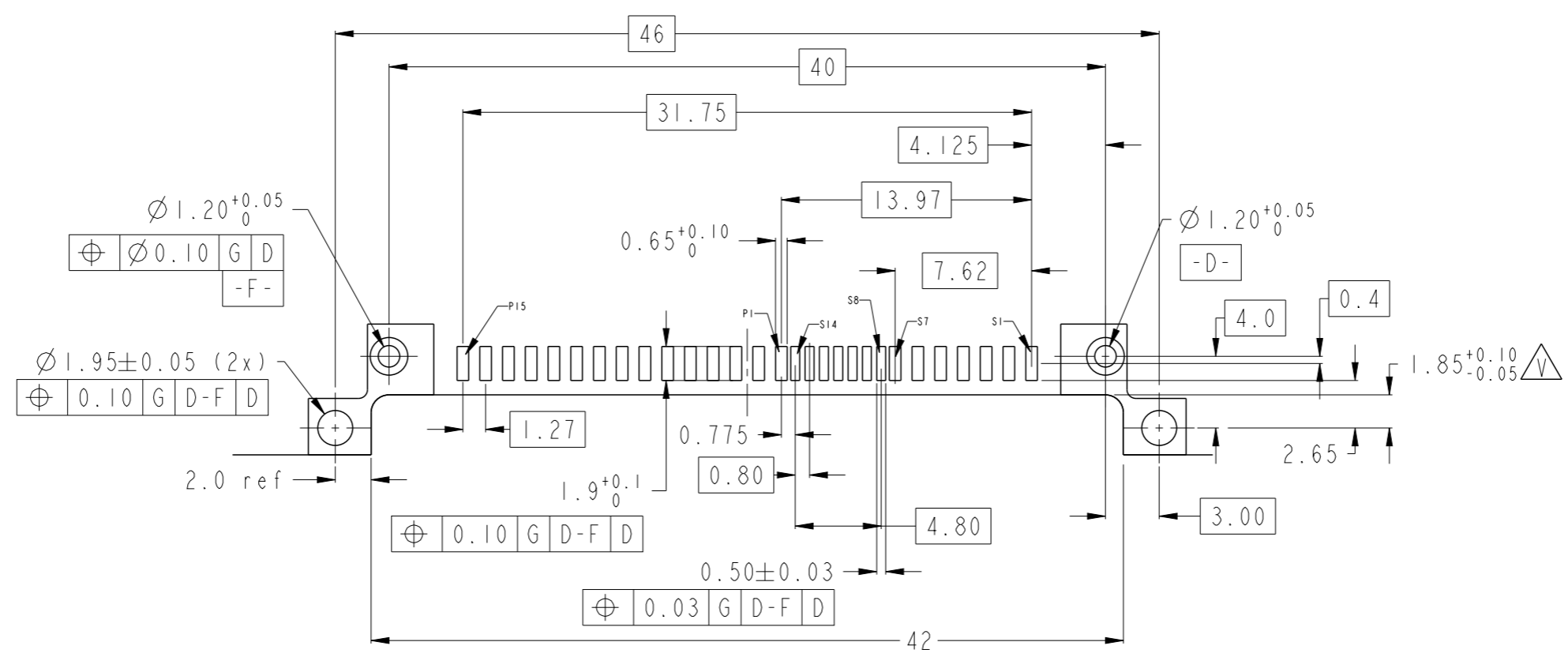

RECOMMENDED PCB LAYOUT
 RECOMMENDED PCB THICKNESS: 1.6mm
 TOLERANCE UNLESS OTHERWISE: ±0.1

C

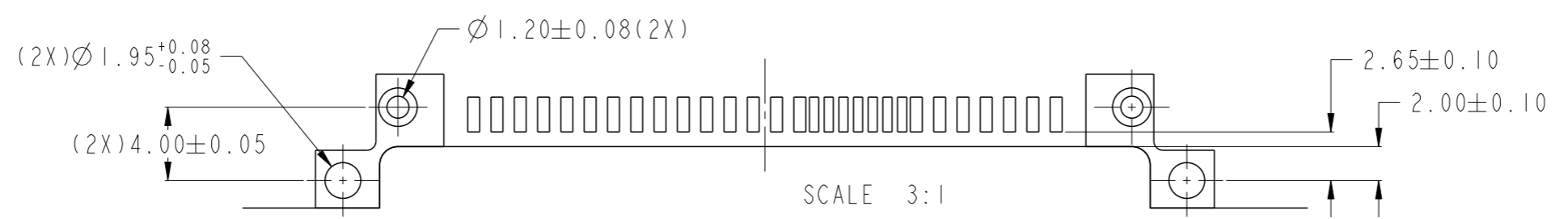

ALTERNATIVE PCB LAYOUT
 REFER TO RECOMMENDED PCB LAYOUT
 FOR UNSPECIFIED DIMENSIONS

D

spec ref	dr	wcadmin	2006/03/10	projection	MM	size	A3	scale	1:1
tolerance std	eng	Jeffrey Lim	2017/07/11			ecn no	ELX-S-27425-1		
ASME Y14.5	chr	-	rel level			Released			
surface	linear	0.X	± -	Amphenol FCI		SAS RECEPTACLE R/A SMT ASSY, Z-HT. 0.35	dwg no 10035202	rev V	
		0.XX	±0.2						
	angular	0°	±2°	cat. no.	-	Product - Customer Drw	sheet 3 of 4		

Amphenol FCI

© 2016 AFCI

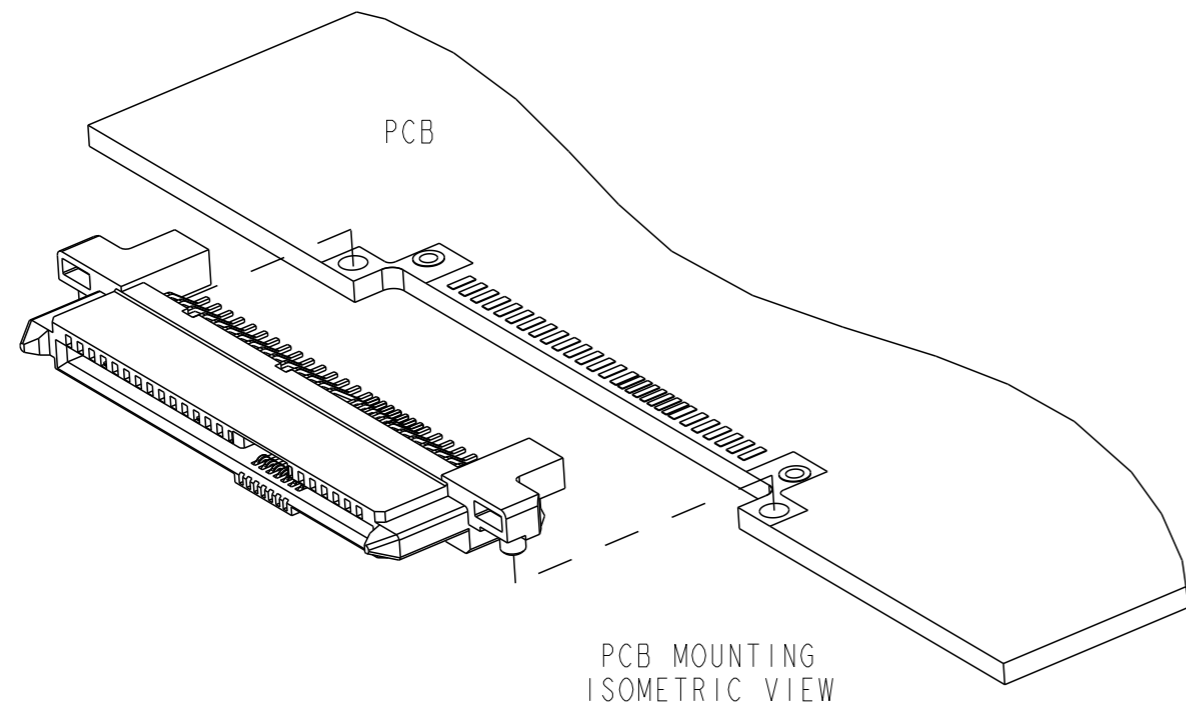

NOTES:-

1. MATERIAL:
 - 1) HOUSING: HIGH TEMP. THERMOPLASTIC, UL 94V-0
COLOR: BLACK.
 - 2) TERMINAL: COPPER ALLOY.
 - 3) HOLD DOWN: COPPER ALLOY.
2. FINISH:
 - 1) TERMINAL: 30u" PLATING (CONTACT POINT) OVER 50u" MIN NICKEL.
 - 2) SOLDER TAIL: 100u" MIN TIN OVER 50u" MIN NICKEL.
 - 3) HOLD DOWN: 100u" MIN OVER 50u" MIN NICKEL.
3. THE STD. PACK IS IN TRAY.
4. THE HOUSING WILL WITHSTAND EXPOSURE TO 260°C PEAK TEMPERATURE FOR 10 SECONDS IN A CONVECTION, INFRA-RED OR VAPOR PHASE REFLOW OVEN.
5. THIS PRODUCT MEETS EUROPEAN UNION DIRECTIVES AND OTHER COUNTRY REGULATIONS AS DESCRIBE IN GS-47-0004
6. PART NUMBERS ENDING IN "LF" MEANT FOR NOTE 5 LEAD FREE IDENTIFICATION. P/N XXXXXXX-XXXLF IS EQUIVALENT TO PREVIOUS P/N XXXXXXX-XXX.
- 7 ALL SOLDER TAIL MUST BE WITHIN 0.10MM, MAX COPLANARITY.
- 8 THIS IS VACUUM NOZZLE PICK-UP AREA.
9. PRODUCT SPEC.: GS-12-282
10. PACKAGING SPEC.: GS-14-841 (TRAY); GS-14-966 (TAPE & REEL)
11. A SYMBOL $\triangle V$ WILL BE NEXT TO ANY DIMENSION, VIEW, OR NOTE WHICH HAS BEEN MODIFIED WITH THE CURRENT DRAWING REVISION.

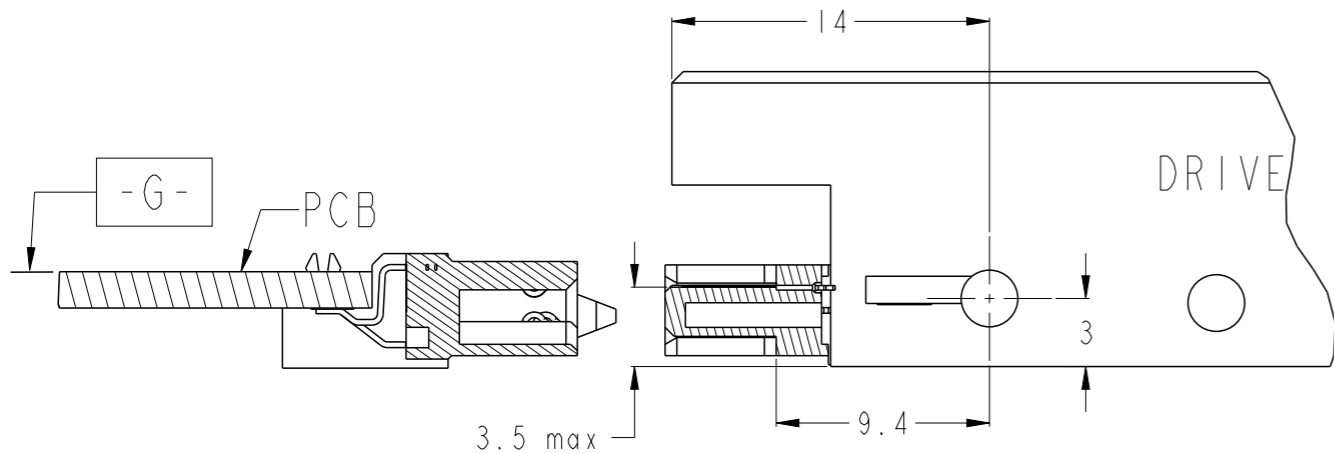

SAS Connector mounting view

spec ref	dr	wcadmin	2006/03/10	projection	MM	size	A3	scale	1:1
tolerance std	eng	Jeffrey Lim	2017/07/11			ecn no	ELX-S-27425-1		
ASME Y14.5	chr	-	rel level				Released		
surface \checkmark linear angular	appr	Koon-Poh Tay	2017/07/28	product family		-	SAS RECEPTACLE R/A SMT ASSY, Z-HT. 0.35	dwg no 10035202	rev V
	TOLERANCES UNLESS OTHERWISE SPECIFIED		0.X ± - 0.XX ±0.2 0.XXX ± - 0° ±2°		cat. no.	-			
	Amphenol FCi		Product - Customer Drw		sheet 4 of 4				