

HF
Halogen Free

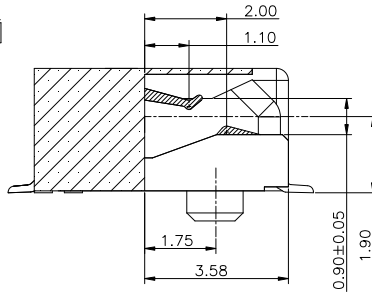

SECTION: A-A
SCALE: 2:1

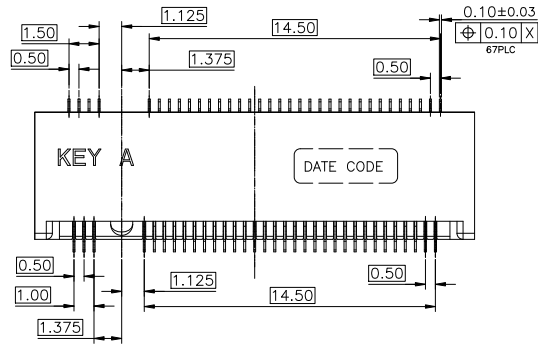
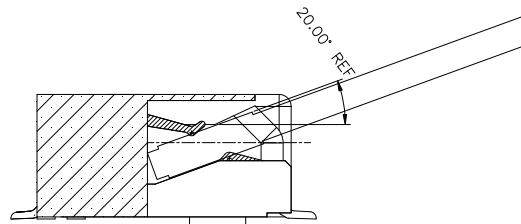
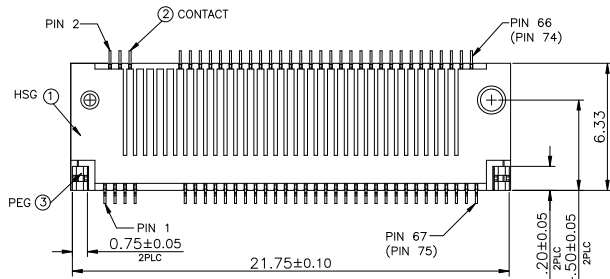
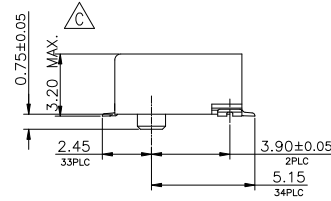
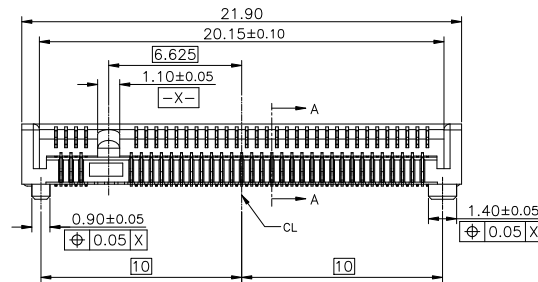

MATING SIMILAR
SCALE: 2:1

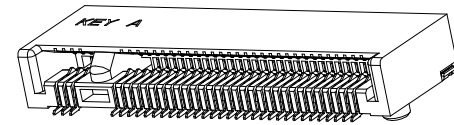

NOTES:

1. MATERIAL:
 - 1.1 HOUSING: HIGH TEMPERATURE THERMOPLASTIC, UL94V-0, COLOR: BLACK.
 - 1.2 CONTACT: COPPER ALLOY.
 - 1.3 SOLDER PEG: STAINLESS STEEL.
2. FINISH:
 - 2.1 CONTACT:
 - UNDERPLATING NICKEL 50u" MIN OVERALL
 - MATING AREA: GOLD PLATING, THICKNESS SEE TABLE
 - SOLDER AREA: GOLD FLASH 1u" MIN.
 - 2.2 SOLDER PEG:
 - UNDERPLATING NICKEL 50u" MIN OVERALL
 - 80u" MIN MATTE TIN ON SURFACE
3. DATE CODE : YYWDLX
 - YY: YEAR (09: 2009)
 - WW: WEEK (25: THE 25TH WEEK)
 - D: DAY (1~7: SUNDAY~SATURDAY)
 - L: LINE NUMBER OF ASSEMBLY (A: LINE A)
 - X: D OR N (D: DAY; N: NIGHT)
4. PRODUCT SPECIFICATION SEE FCI GS-12-1195
5. PART NUMBER DESCRIPTION:
 - 10128786-00XRLF

LF: LEAD FREE & RoHS COMPLIANCE

PACKAGE CODE:

R: TAPE & REEL PACKING

PLATING CODE:

1: GOLD FLASH ON CONTACT AREA

4: 15u" Min GOLD ON CONTACT AREA

5: 30u" Min GOLD ON CONTACT AREA

mat'l. code		surface	tolerance	projection	product family
ltr	ecn no	dr	date	tolerances unless otherwise specified	title
A		BF	2013-04-18	angles	M.2 CONNECTOR 3.2H_STD_KEY A
B	ELX-T-19318	TAI	2014-11-10	mm	
C	ELX-T-20858	TAI	2015-05-11	scale	
				dr	BEER FU
				enrg	BEER FU
				chr	BEER FU
				appd	BEER FU
					2013-05-02
					2013-05-02
					2013-05-02
sheet	revision	C	C	C	FCI
index	sheet	1	2	3	Customer Drawing

30u" Au	10128786-005RLF
15u" Au	10128786-004RLF
GOLD FLASH	10128786-001RLF
CONTACT AREA	FCI P/N

HF
Halogen Free

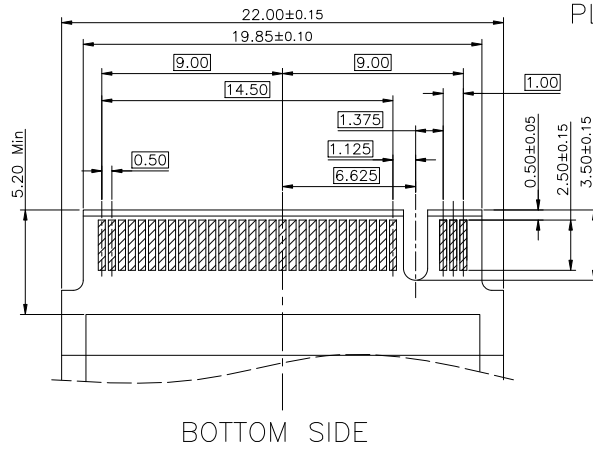

PLUG PCB

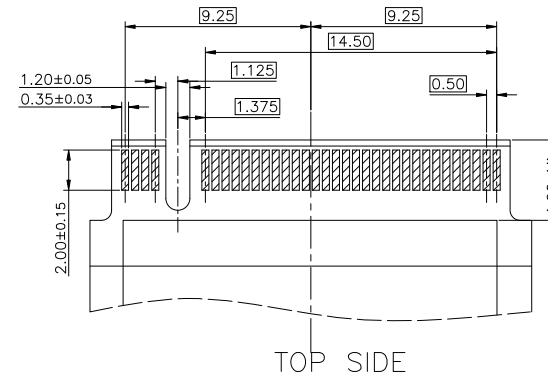
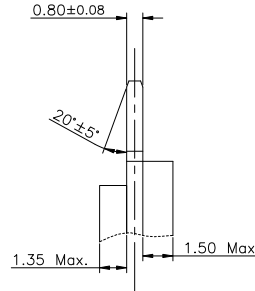

BOTTOM SIDE

TOP SIDE

RECOMMENDED NGFF MOUNTING TYP PCB_LAYOUT

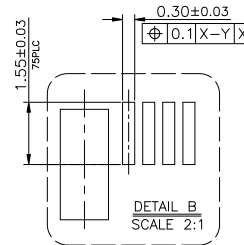
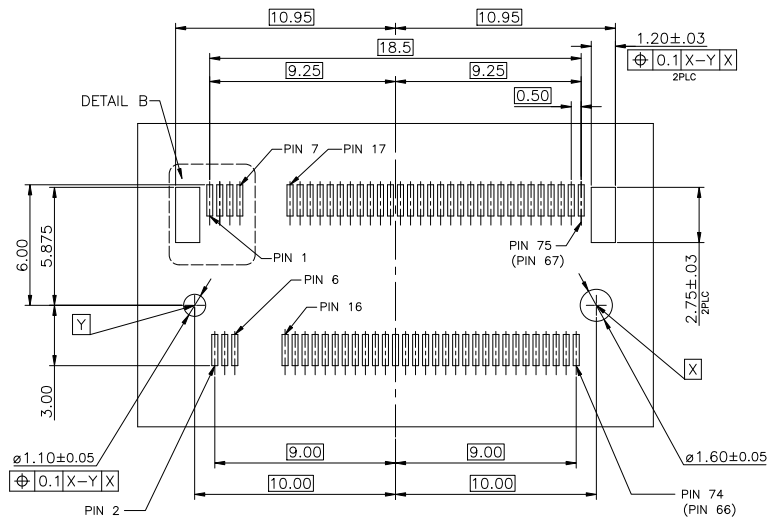

	dwg no	sheet 2 of 3	size
	10128786		A4
	type Customer Drawing		

sheet index	revision sheet	C 1	C 2	C 3															
-------------	----------------	-----	-----	-----	--	--	--	--	--	--	--	--	--	--	--	--	--	--	--

HF
Halogen Free



FEEDING DIRECTION

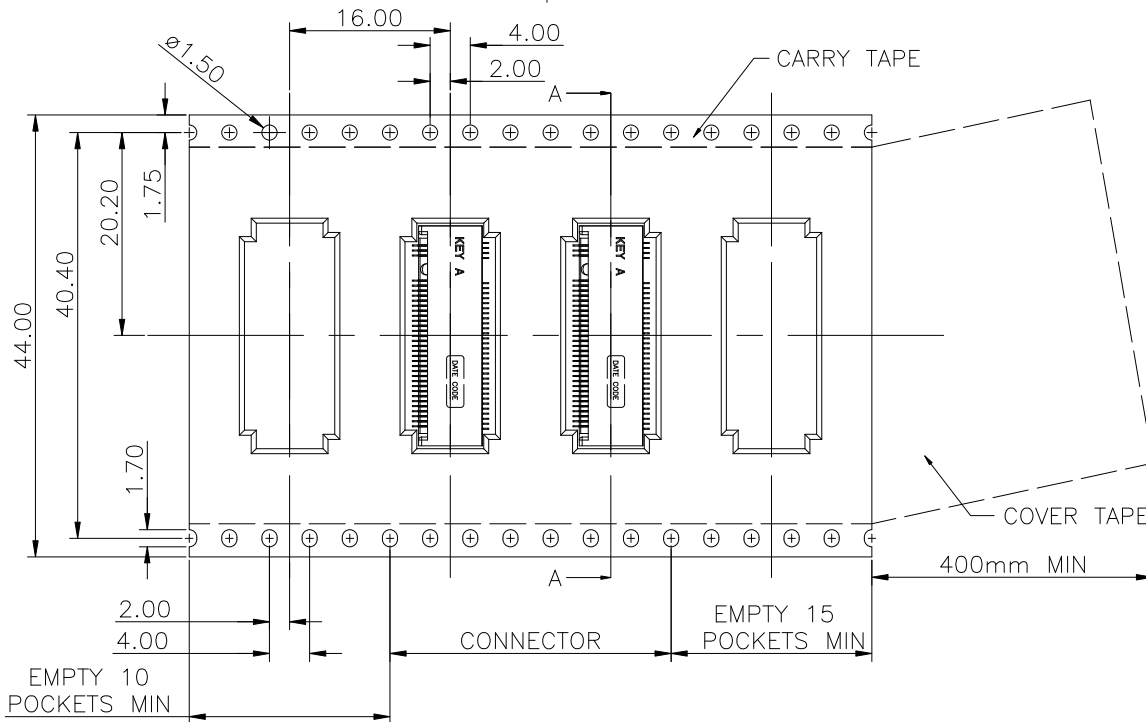
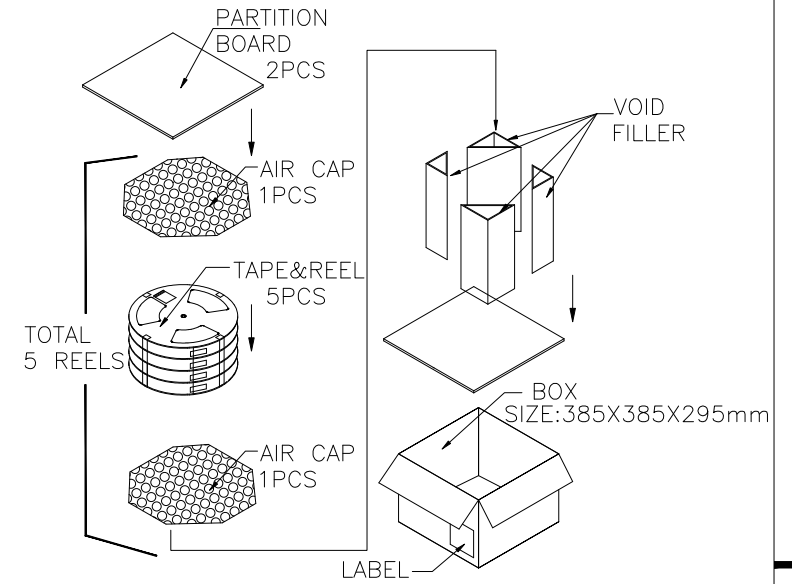
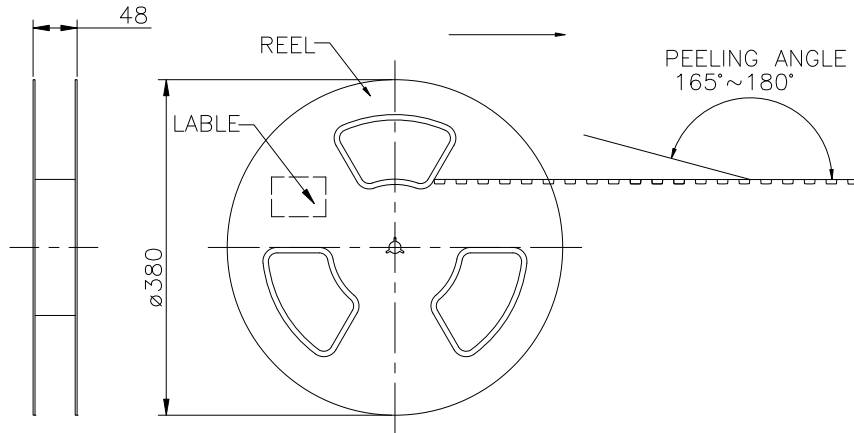

1400	5	7000	7.85Kg	3.5Kg
PCS/REEL	REELS/BOX	PCS/BOX	GROSS WEIGHT	NET WEIGHT

FCI	dwg no	sheet 3 of 3	size
	10128786		A4
	type Customer Drawing		

sheet index	revision sheet	C	C	C															
		1	2	3															