

1 2 3 4 5 6 7

A

A

B

B

C

C

D

D

E

E

F

F

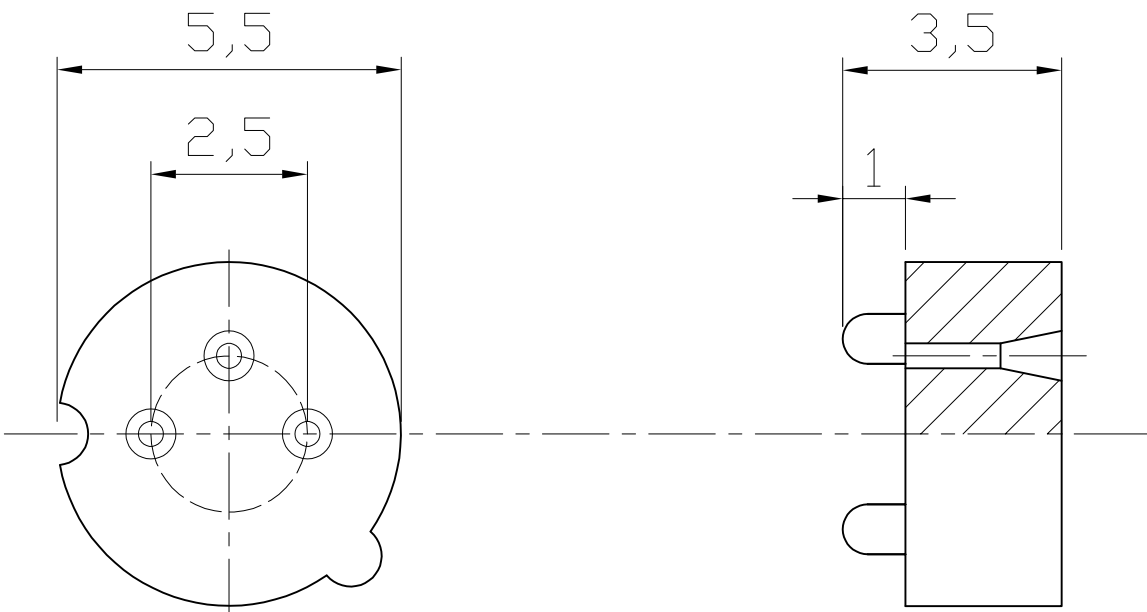

RoHS compliant
Unit:mm

Material : PA 6

Scale	1:1					Date	Name	Customer-No.
TOLERANCE					Drawn	20.08.2009	Dean	
X.	±X	④	Change Material	01.07.2021	Larsen	Approved	01.07.2021	Larsen
X.X	±X	③	Material add.	31.05.2011	Schulz			
X.XX	±X	②	Modify drawing layout	10.03.2010	Alex			
DIM	TOL	①	Drawn	20.08.2009	Dean			
X.°	±X°							Drawing-No.
X.X°	±X°							ASS 0925 HS
Angle	TOL	Id.	Modification	Date	Name			Replace
								rev04
								Sheet

1 2 3 4 5 6 7

G

G

H

H