

57MHz, Wideband, Four Quadrant, Voltage Output Analog Multiplier

The HA-2556 is a monolithic, high speed, four quadrant, analog multiplier constructed in the Intersil Dielectrically Isolated High Frequency Process. The voltage output simplifies many designs by eliminating the current-to-voltage conversion stage required for current output multipliers. The HA-2556 provides a 450V/μs slew rate and maintains 52MHz and 57MHz bandwidths for the X and Y channels respectively, making it an ideal part for use in video systems.

The suitability for precision video applications is demonstrated further by the Y-Channel 0.1dB gain flatness to 5.0MHz, 1.5% multiplication error, -50dB feedthrough and differential inputs with 8μA bias current. The HA-2556 also has low differential gain (0.1%) and phase (0.1°) errors.

The HA-2556 is well suited for AGC circuits as well as mixer applications for sonar, radar, and medical imaging equipment. The HA-2556 is not limited to multiplication applications only; frequency doubling, power detection, as well as many other configurations are possible.

Ordering Information

PART NUMBER (Note)	PART MARKING	TEMP RANGE (°C)	PACKAGE (Pb-free)	PKG DWG. #
HA9P2556-9Z	HA9P2556 -9Z	-40 to +85	16 Ld SOIC	M16.3

NOTE: These Intersil Pb-free plastic packaged products employ special Pb-free material sets, molding compounds/die attach materials, and 100% matte tin plate plus anneal (e3 termination finish, which is RoHS compliant and compatible with both SnPb and Pb-free soldering operations). Intersil Pb-free products are MSL classified at Pb-free peak reflow temperatures that meet or exceed the Pb-free requirements of IPC/JEDEC J STD-020

Features

- High Speed Voltage Output 450V/μs
- Low Multiplication Error 1.5%
- Input Bias Currents 8μA
- 5MHz Feedthrough -50dB
- Wide Y-Channel Bandwidth 57MHz
- Wide X-Channel Bandwidth 52MHz
- V_Y 0.1dB Gain Flatness 5.0MHz
- Pb-free (RoHS compliant)

Applications

- Military Avionics
- Missile Guidance Systems
- Medical Imaging Displays
- Video Mixers
- Sonar AGC Processors
- Radar Signal Conditioning
- Voltage Controlled Amplifier
- Vector Generators

Functional Block Diagram

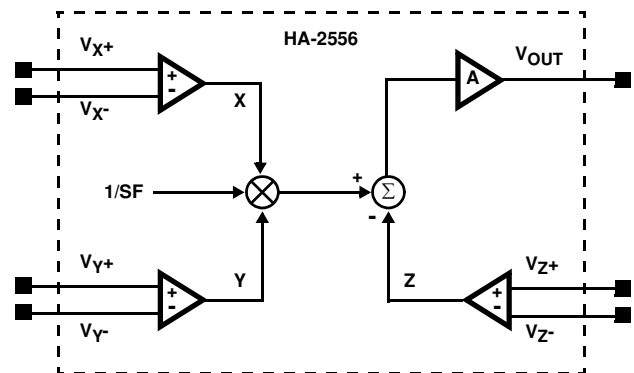

NOTE: The transfer equation for the HA-2556 is:
 $(V_{X+} - V_{X-}) (V_{Y+} - V_{Y-}) = S_F (V_{Z+} - V_{Z-})$,
 where SF = Scale Factor = 5V; V_X, V_Y,
 V_Z = Differential Inputs.

Pinout

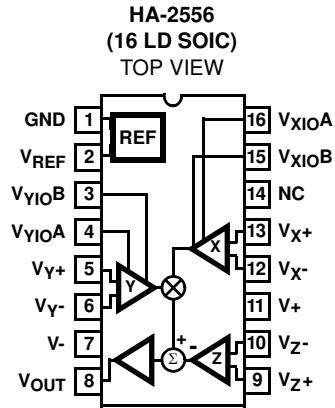

Absolute Maximum Ratings

Voltage Between V+ and V- Terminals 35V
 Differential Input Voltage 6V
 Output Current ±60mA

Thermal Information

Thermal Resistance (Typical, Note 1) θ_{JA} (°C/W) θ_{JC} (°C/W)
 16 Ld SOIC Package 90 N/A
 Maximum Junction Temperature (Plastic Packages) +150°C
 Maximum Storage Temperature Range -65°C to +150°C
 Pb-Free Reflow Profile see link below
<http://www.intersil.com/pbfree/Pb-FreeReflow.asp>

Operating Conditions

Temperature Range -40°C to +85°C

CAUTION: Do not operate at or near the maximum ratings listed for extended periods of time. Exposure to such conditions may adversely impact product reliability and result in failures not covered by warranty.

NOTE:

1. θ_{JA} is measured with the component mounted on a low effective thermal conductivity test board in free air. See Tech Brief TB379 for details.

Electrical Specifications $V_{SUPPLY} = \pm 15V$, $R_F = 50\Omega$, $R_L = 1k\Omega$, $C_L = 20pF$, Unless Otherwise Specified.

PARAMETER	TEST CONDITIONS	TEMP (°C)	MIN (Note 10)	TYP	MAX (Note 10)	UNITS
MULTIPLIER PERFORMANCE						
Transfer Function			$V_{OUT} = A \left[\frac{(V_{X+} - V_{X-}) \times (V_{Y+} - V_{Y-})}{5} - (V_{Z+} - V_{Z-}) \right]$			
Multiplication Error	(Note 2)	+25	-	1.5	3	%
		Full	-	3.0	6	%
Multiplication Error Drift		Full	-	0.003	-	%/°C
Scale Factor		+25	-	5	-	V
Linearity Error	$V_X, V_Y = \pm 3V$, Full Scale = 3V	+25	-	0.02	-	%
	$V_X, V_Y = \pm 4V$, Full Scale = 4V	+25	-	0.05	0.25	%
	$V_X, V_Y = \pm 5V$, Full Scale = 5V	+25	-	0.2	0.5	%
AC CHARACTERISTICS						
Small Signal Bandwidth (-3dB)	$V_Y = 200mV_{P-P}$, $V_X = 5V$	+25	-	57	-	MHz
	$V_X = 200mV_{P-P}$, $V_Y = 5V$	+25	-	52	-	MHz
Full Power Bandwidth (-3dB)	10V _{P-P}	+25	-	32	-	MHz
Slew Rate	(Note 5)	+25	420	450	-	V/ μ s
Rise Time	(Note 6)	+25	-	8	-	ns
Overshoot	(Note 6)	+25	-	20	-	%
Settling Time	To 0.1%, (Note 5)	+25	-	100	-	ns
Differential Gain	(Note 3)	+25	-	0.1	0.2	%
Differential Phase	(Note 3)	+25	-	0.1	0.3	°
V_Y 0.1dB Gain Flatness	200mV _{P-P} , $V_X = 5V$,	+25	4.0	5.0	-	MHz
V_X 0.1dB Gain Flatness	200mV _{P-P} , $V_Y = 5V$,	+25	2.0	4.0	-	MHz
THD + N	(Note 4)	+25	-	0.03	-	%
1MHz Feedthrough	200mV _{P-P} , Other Channel Nulled	+25	-	-65	-	dB
5MHz Feedthrough	200mV _{P-P} , Other Channel Nulled	+25	-	-50	-	dB
SIGNAL INPUT (V_X, V_Y, V_Z)						
Input Offset Voltage		+25	-	3	15	mV
		Full	-	8	25	mV
Average Offset Voltage Drift		Full	-	45	-	μ V/°C
Input Bias Current		+25	-	8	15	μ A
		Full	-	12	20	μ A

Electrical Specifications $V_{SUPPLY} = \pm 15V$, $R_F = 50\Omega$, $R_L = 1k\Omega$, $C_L = 20pF$, Unless Otherwise Specified. (Continued)

PARAMETER	TEST CONDITIONS	TEMP (°C)	MIN (Note 10)	TYP	MAX (Note 10)	UNITS
Input Offset Current		+25	-	0.5	2	μA
		Full	-	1.0	3	μA
Differential Input Resistance		+25	-	1	-	$M\Omega$
Full Scale Differential Input (V_X , V_Y , V_Z)		+25	± 5	-	-	V
V_X Common Mode Range		+25	-	± 10	-	V
V_Y Common Mode Range		+25	-	+9, -10	-	V
CMRR Within Common Mode Range		Full	65	78	-	dB
Voltage Noise (Note 8)	f = 1kHz	+25	-	150	-	nV/\sqrt{Hz}
	f = 100kHz	+25	-	40	-	nV/\sqrt{Hz}
OUTPUT CHARACTERISTICS						
Output Voltage Swing	(Note 9)	Full	± 5.0	± 6.05	-	V
Output Current		Full	± 20	± 45	-	mA
Output Resistance		+25	-	0.7	1.0	Ω
POWER SUPPLY						
+PSRR	(Note 7)	Full	65	80	-	dB
-PSRR	(Note 7)	Full	45	55	-	dB
Supply Current		Full	-	18	22	mA

NOTES:

2. Error is percent of full scale, 1% = 50mV.
3. f = 4.43MHz, $V_Y = 300mV_{P-P}$, $0V_{DC}$ to $1V_{DC}$ offset, $V_X = 5V$.
4. f = 10kHz, $V_Y = 1V_{RMS}$, $V_X = 5V$.
5. $V_{OUT} = 0V$ to $\pm 4V$.
6. $V_{OUT} = 0mV$ to $\pm 100mV$.
7. $V_S = \pm 12V$ to $\pm 15V$.
8. $V_X = V_Y = 0V$.
9. $V_X = 5.5V$, $V_Y = \pm 5.5V$.
10. Parameters with MIN and/or MAX limits are 100% tested at +25°C, unless otherwise specified. Temperature limits established by characterization and are not production tested.

Simplified Schematic

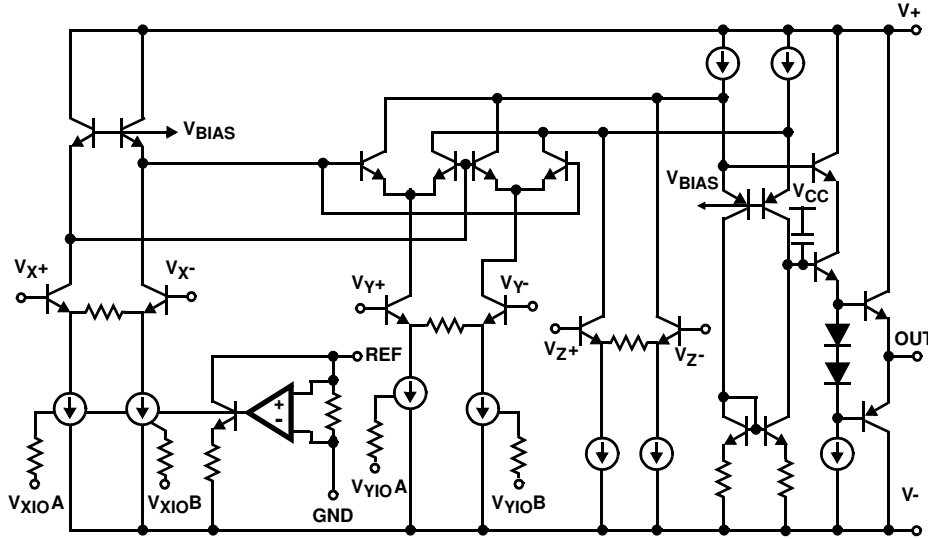

Application Information

Operation at Reduced Supply Voltages

The HA-2556 will operate over a range of supply voltages, ±5V to ±15V. Use of supply voltages below ±12V will reduce input and output voltage ranges. See “Typical Performance Curves” on page 12 for more information.

Offset Adjustment

X-Channel and Y-Channel offset voltages may be nulled by using a 20k potentiometer between the VYIO or VXIO adjust pin A and B and connecting the wiper to V-. Reducing the channel offset voltage, will reduce AC feedthrough and improve the multiplication error. Output offset voltage can also be nulled by connecting VZ- to the wiper of a potentiometer which is tied between V+ and V-.

Capacitive Drive Capability

When driving capacitive loads >20pF a 50Ω resistor should be connected between VOUT and VZ+, using VZ+ as the output (see Figure 1). This will prevent the multiplier from going unstable and reduce gain peaking at high frequencies. The 50Ω resistor will dampen the resonance formed with the capacitive load and the inductance of the output at Pin 8. Gain accuracy will be maintained because the resistor is inside the feedback loop.

Theory of Operation

The HA-2556 creates an output voltage that is the product of the X and Y input voltages divided by a constant scale factor of 5V. The resulting output has the correct polarity in each of the four quadrants defined by the combinations of positive and negative X and Y inputs. The Z stage provides the means for negative feedback (in the multiplier configuration) and an input for summation into the output. This results in Equation 1, where X, Y and Z are high impedance differential inputs.

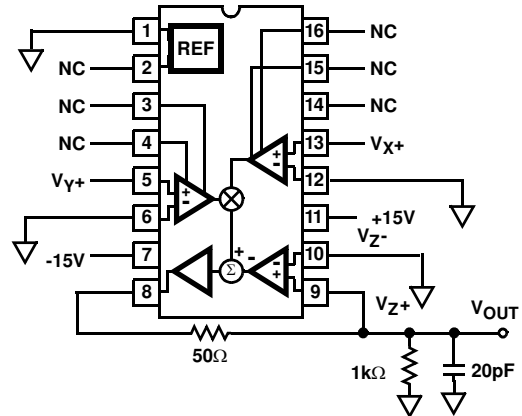

FIGURE 1. DRIVING CAPACITIVE LOAD

$$V_{OUT} = Z = \frac{X \times Y}{5} \tag{EQ. 1}$$

To accomplish this the differential input voltages are first converted into differential currents by the X and Y input transconductance stages. The currents are then scaled by a constant reference and combined in the multiplier core. The multiplier core is a basic Gilbert Cell that produces a differential output current proportional to the product of X and Y input signal currents. This current becomes the output for the HA-2557.

The HA-2556 takes the output current of the core and feeds it to a transimpedance amplifier, that converts the current to a voltage. In the multiplier configuration, negative feedback is provided with the Z transconductance amplifier by connecting VOUT to the Z input. The Z stage converts VOUT to a current which is subtracted from the multiplier core before being applied to the high gain transimpedance amp. The Z stage, by virtue of it’s similarity to the X and Y stages, also cancels second order errors introduced by the dependence of VBE on collector current in the X and Y stages.

The purpose of the reference circuit is to provide a stable current, used in setting the scale factor to 5V. This is achieved with a bandgap reference circuit to produce a temperature stable voltage of 1.2V which is forced across a NiCr resistor. Slight adjustments to scale factor may be possible by overriding the internal reference with the V_{REF} pin. The scale factor is used to maintain the output of the multiplier within the normal operating range of ±5V when full scale inputs are applied.

The Balance Concept

The open loop transfer for the HA-2556 is calculated using Equation 2:

$$V_{OUT} = A \left[\frac{(V_{X+} - V_{X-}) \times (V_{Y+} - V_{Y-})}{5V} - (V_{Z+} - V_{Z-}) \right] \tag{EQ. 2}$$

where;

- A = Output Amplifier Open Loop Gain
- V_X, V_Y, V_Z = Differential Input Voltages
- 5V = Fixed Scaled Factor

An understanding of the transfer function can be gained by assuming that the open loop gain, A, of the output amplifier is infinite. With this assumption, any value of V_{OUT} can be generated with an infinitesimally small value for the terms within the brackets. Therefore we can write Equation 3:

$$0 = \frac{(V_{X+} - V_{X-}) \times (V_{Y+} - V_{Y-})}{5V} - (V_{Z+} - V_{Z-}) \tag{EQ. 3}$$

which simplifies to Equation 4:

$$(V_{X+} - V_{X-}) \times (V_{Y+} - V_{Y-}) = 5V (V_{Z+} - V_{Z-}) \tag{EQ. 4}$$

This form of the transfer equation provides a useful tool to analyze multiplier application circuits and will be called the Balance Concept.

Typical Applications

Let's first examine the Balance Concept as it applies to the standard multiplier configuration (Figure 2).

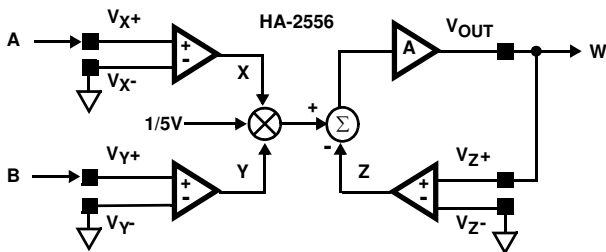

FIGURE 2. MULTIPLIER

Signals A and B are input to the multiplier and the signal W is the result. By substituting the signal values into the Balance equation yields Equation 5:

$$(A) \times (B) = 5(W) \tag{EQ. 5}$$

And solving for W yields Equation 6:

$$W = \frac{A \times B}{5} \tag{EQ. 6}$$

Notice that the output (W) enters the equation in the feedback to the Z stage. The Balance Equation does not test for stability, so remember that you must provide negative feedback. In the multiplier configuration, the feedback path is connected to V_{Z+} input, not V_{Z-}. This is due to the inversion that takes place at the summing node just prior to the output amplifier. Feedback is not restricted to the Z stage, other feedback paths are possible as in the Divider Configuration shown in Figure 3.

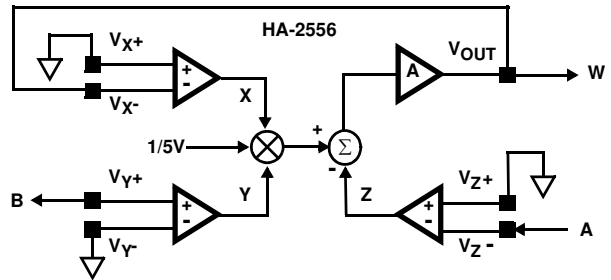

FIGURE 3. DIVIDER

Inserting the signal values A, B and W into the Balance Equation for the divider configuration yields Equation 7:

$$(-W) (B) = 5V \times (-A) \tag{EQ. 7}$$

Solving for W yields Equation 8:

$$W = \frac{5A}{B} \tag{EQ. 8}$$

Notice that, in the divider configuration, signal B must remain ≥0 (positive) for the feedback to be negative. If signal B is negative, then it will be multiplied by the V_{X-} input to produce positive feedback and the output will swing into the rail.

Signals may be applied to more than one input at a time as in the Squaring configuration in Figure 4:

Here the Balance equation will appear as Equation 9:

$$(A) \times (A) = 5(W) \tag{EQ. 9}$$

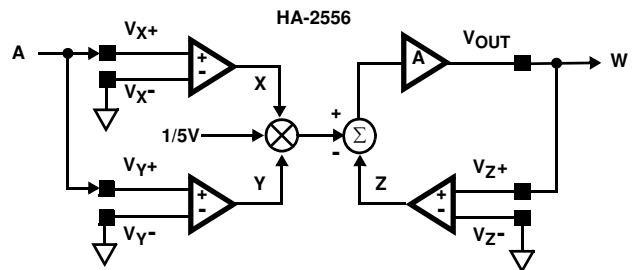

FIGURE 4. SQUARE

Which simplifies to Equation 10:

$$W = \frac{A^2}{5} \tag{EQ. 10}$$

The last basic configuration is the Square Root as shown in Figure 5. Here feedback is provided to both X and Y inputs.

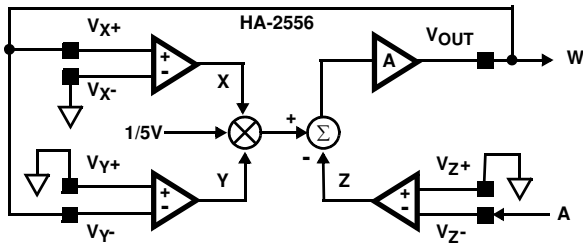

FIGURE 5. SQUARE ROOT (FOR A > 0)

The Balance equation takes the form of Equation 11:

$$(W) \times (-W) = 5(-A) \tag{EQ. 11}$$

Which equates to Equation 12:

$$W = \sqrt{5A} \tag{EQ. 12}$$

The four basic configurations (Multiply, Divide, Square and Square Root) as well as variations of these basic circuits have many uses.

Frequency Doubler

For example, if $ACos(\omega\tau)$ is substituted for signal A in the Square function, then it becomes a Frequency Doubler and the equation takes the form of Equation 13:

$$(ACos(\omega\tau)) \times (ACos(\omega\tau)) = 5(W) \tag{EQ. 13}$$

And using some trigonometric identities gives the result in Equation 14:

$$W = \frac{A^2}{10}(1 + Cos(2\omega\tau)) \tag{EQ. 14}$$

Square Root

The Square Root function can serve as a precision/wide bandwidth compander for audio or video applications. A compander improves the Signal-to-Noise Ratio for your system by amplifying low level signals while attenuating or compressing large signals (refer to Figure 17; $X^{0.5}$ curve). This provides for better low level signal immunity to noise during transmission. On the receiving end, the original signal may be reconstructed with the standard Square function.

Communications

The Multiplier configuration has applications in AM Signal Generation, Synchronous AM Detection and Phase Detection to mention a few. These circuit configurations are shown in Figures 6, 7 and 8. The HA-2556 is particularly useful in applications that require high speed signals on all inputs.

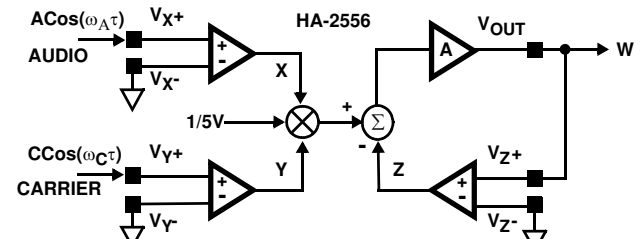

$$W = \frac{AC}{10}(Cos(\omega_C - \omega_A)\tau + Cos(\omega_C + \omega_A)\tau)$$

FIGURE 6. AM SIGNAL GENERATION

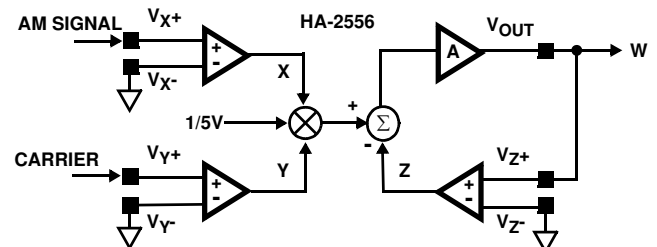

LIKE THE FREQUENCY DOUBLER YOU GET AUDIO CENTERED AT DC AND $2F_C$.

FIGURE 7. SYNCHRONOUS AM DETECTION

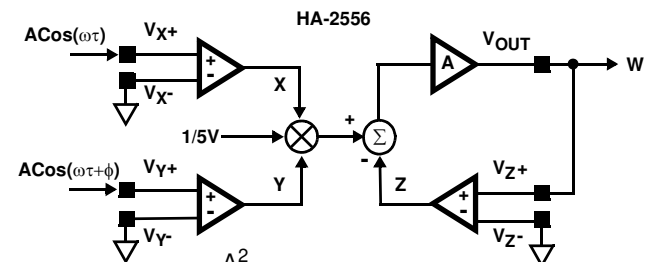

$$W = \frac{A^2}{10}(Cos(\phi) + Cos(2\omega\tau + \phi))$$

DC COMPONENT IS PROPORTIONAL TO COS(phi)

FIGURE 8. PHASE DETECTION

Each input X, Y and Z have similar wide bandwidth and input characteristics. This is unlike earlier products where one input was dedicated to a slow moving control function as is required for Automatic Gain Control. The HA-2556 is versatile enough for both.

Although the X and Y inputs have similar AC characteristics, they are not the same. The designer should consider input parameters such as small signal bandwidth, AC feedthrough and 0.1dB gain flatness to get the most performance from the HA-2556. The Y-Channel is the faster of the two inputs with a small signal bandwidth of typically 57MHz vs 52MHz for the X-Channel. Therefore in AM Signal Generation, the best performance will be obtained with the Carrier applied to the Y-Channel and the modulation signal (lower frequency) applied to the X-Channel.

Scale Factor Control

The HA-2556 is able to operate over a wide supply voltage range $\pm 5V$ to $\pm 17.5V$. The $\pm 5V$ range is particularly useful in video applications. At $\pm 5V$ the input voltage range is reduced to $\pm 1.4V$. The output cannot reach its full scale value with this restricted input, so it may become necessary to modify the scale factor. Adjusting the scale factor may also be useful when the input signal itself is restricted to a small portion of the full scale level. Here, we can make use of the high gain output amplifier by adding external gain resistors. Generating the maximum output possible for a given input signal will improve the Signal-to-Noise Ratio and Dynamic Range of the system. For example, let's assume that the input signals are $1V_{PEAK}$ each then, the maximum output for the HA-2556 will be 200mV. $(1V \times 1V)/(5V) = 200mV$. It would be nice to have the output at the same full scale as our input, so let's add a gain of 5 as shown in Figure 9.

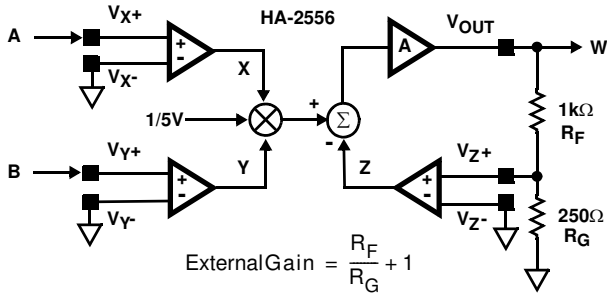

FIGURE 9. EXTERNAL GAIN OF 5

One caveat is that the output bandwidth will also drop by this factor of 5. The multiplier equation then becomes Equation 15:

$$W = \frac{5AB}{5} = A \times B \tag{EQ. 15}$$

Current Output

Another useful circuit for low voltage applications allows the user to convert the voltage output of the HA2556 to an output current. The HA-2557 is a current output version offering

100MHz of bandwidth, but its scale factor is fixed and does not have an output amplifier for additional scaling. Fortunately, the circuit in Figure 10 provides an output current that can be scaled with the value of $R_{CONVERT}$ and provides an output impedance of typically $1M\Omega$. I_{OUT} then becomes Equation 16:

$$I_{OUT} = \frac{A \times B}{5} \times \frac{1}{R_{CONVERT}} \tag{EQ. 16}$$

Video Fader

The Video Fader circuit provides a unique function. Here Channel B is applied to the minus Z input in addition to the minus Y input. In this way, the function in Figure 11 is generated. V_{MIX} will control the percentage of Channel A and Channel B that are mixed together to produce a resulting video image or other signal.

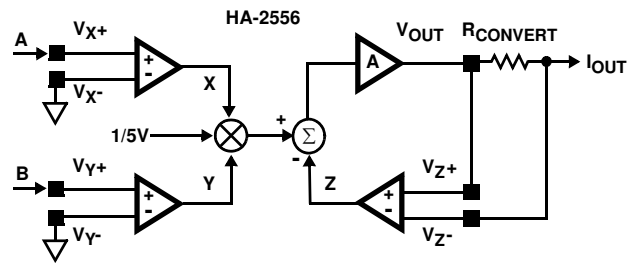

FIGURE 10. CURRENT OUTPUT

The Balance equation looks like Equation 17:

$$(V_{MIX}) \times (ChA - ChB) = 5(V_{OUT} - ChB) \tag{EQ. 17}$$

Which simplifies to Equation 18:

$$V_{OUT} = ChB + \frac{V_{MIX}}{5}(ChA - ChB) \tag{EQ. 18}$$

When V_{MIX} is 0V the equation becomes $V_{OUT} = ChB$ and ChA is removed, conversely when V_{MIX} is 5V the equation becomes $V_{OUT} = ChA$ eliminating ChB . For V_{MIX} values $0V \leq V_{MIX} \leq 5V$ the output is a blend of ChA and ChB .

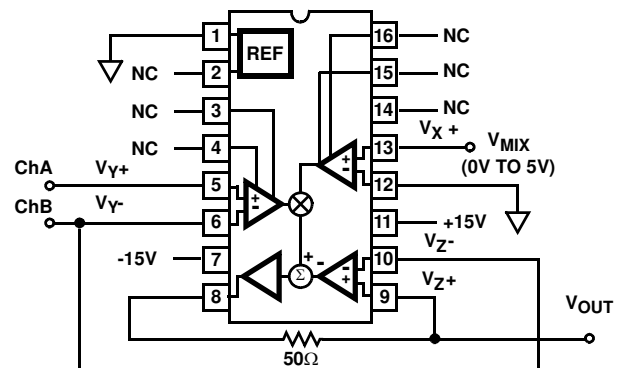

FIGURE 11. VIDEO FADER

Other Applications

As previously shown, a function may contain several different operators at the same time and use only one

HA-2556. Some other possible multi-operator functions are shown in Figures 12, 13 and 14.

Of course the HA-2556 is also well suited to standard multiplier applications such as Automatic Gain Control and Voltage Controlled Amplifier.

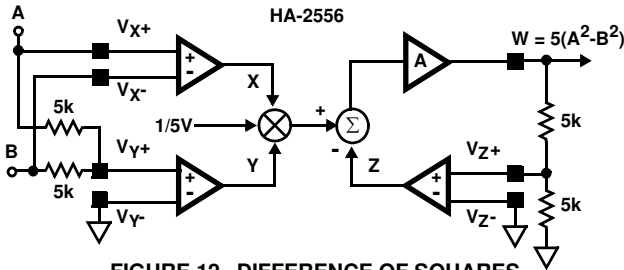
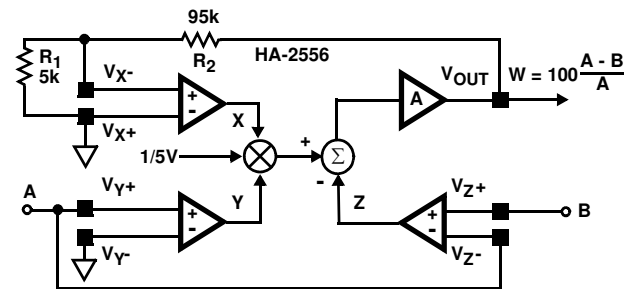

FIGURE 12. DIFFERENCE OF SQUARES



R₁ and R₂ set scale to 1V/%, other scale factors possible. For A ≥ 0V.

FIGURE 13. PERCENTAGE DEVIATION

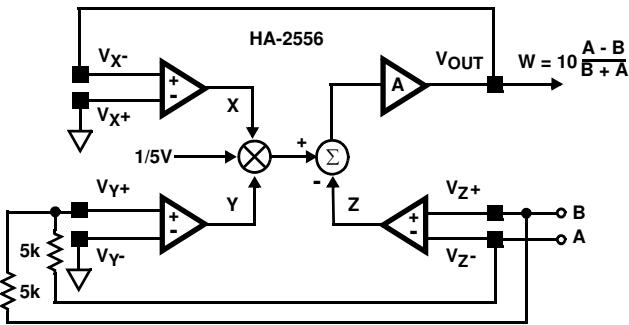

FIGURE 14. DIFFERENCE DIVIDED BY SUM S (For A + B ≥ 0V)

Automatic Gain Control

Figure 15 shows the HA-2556 configured in an Automatic Gain Control or AGC application. The HA-5127 low noise amplifier provides the gain control signal to the X input. This control signal sets the peak output voltage of the multiplier to match the preset reference level. The feedback network around the HA-5127 provides a response time adjustment. High frequency changes in the peak are rejected as noise or the desired signal to be transmitted. These signals do not indicate a change in the average peak value and therefore no gain adjustment is needed. Lower frequency changes in the peak value are given a gain of -1 for feedback to the

control input. At DC the circuit is an integrator automatically compensating for Offset and other constant error terms.

This multiplier has the advantage over other AGC circuits, in that the signal bandwidth is not affected by the control signal gain adjustment.

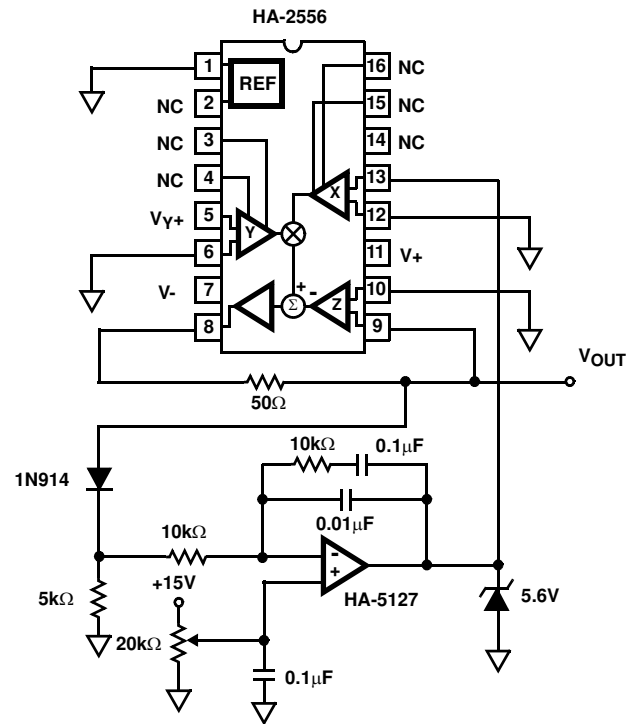

FIGURE 15. AUTOMATIC GAIN CONTROL

Voltage Controlled Amplifier

A wide range of gain adjustment is available with the Voltage Controlled Amplifier configuration shown in Figure 16. Here the gain of the HFA0002 can be swept from 20V/V to a gain of almost 1000V/V with a DC voltage from 0V to 5V.

Wave Shaping Circuits

Wave shaping or curve fitting is another class of application for the analog multiplier. For example, where a nonlinear sensor requires corrective curve fitting to improve linearity the HA-2556 can provide nonintegral powers in the range of 1 to 2 or nonintegral roots in the range of 0.5 to 1.0 (refer to "References" on page 11). This effect is displayed in Figure 17.

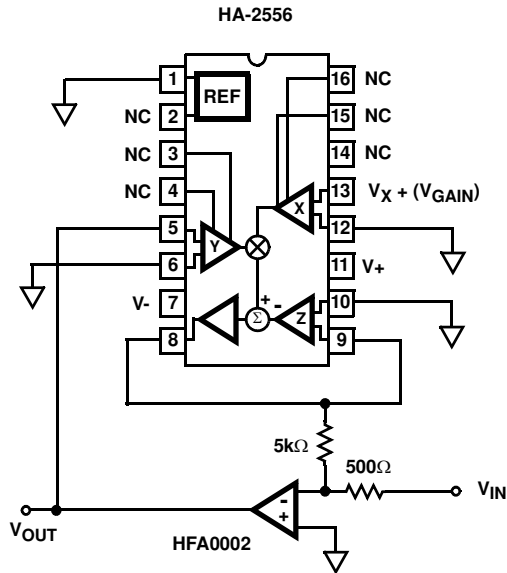

FIGURE 16. VOLTAGE CONTROLLED AMPLIFIER

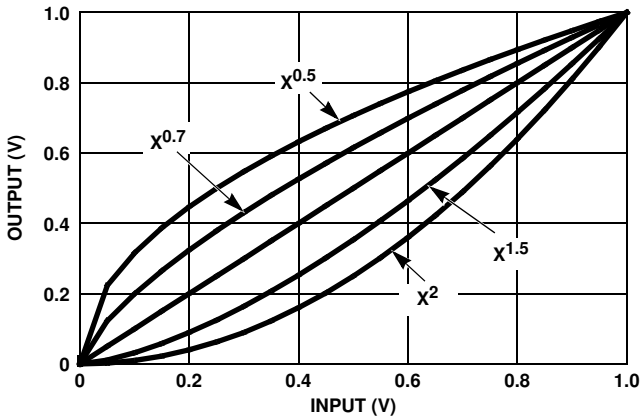

FIGURE 17. EFFECT OF NONINTEGRAL POWERS/ROOTS

A multiplier can't do nonintegral roots "exactly", but it can yield a close approximation. We can approximate nonintegral roots with Equations 19 and 20 of the form:

$$V_O = (1 - \alpha)V_{IN}^2 + \alpha V_{IN} \quad (\text{EQ. 19})$$

$$V_O = (1 - \alpha)V_{IN}^{1/2} + \alpha V_{IN} \quad (\text{EQ. 20})$$

Figure 18 compares the function $V_{OUT} = V_{IN}^{0.7}$ to the approximation $V_{OUT} = 0.5V_{IN}^{0.5} + 0.5V_{IN}$.

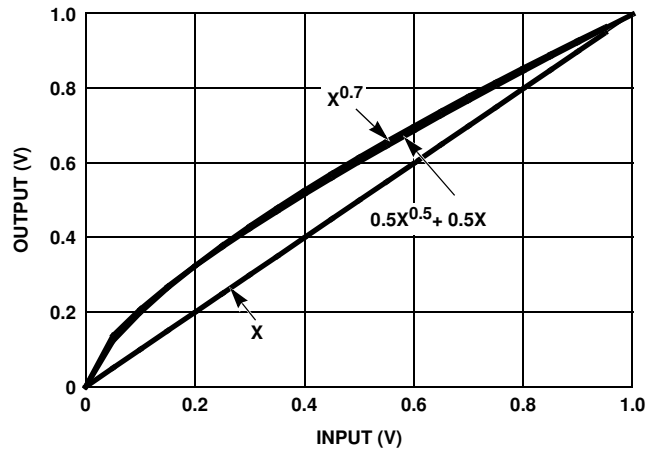

FIGURE 18. COMPARE APPROXIMATION TO NONINTEGRAL ROOT

This function can be easily built using an HA-2556 and a potentiometer for easy adjustment as shown in Figures 19 and 20. If a fixed nonintegral power is desired, the circuit shown in Figure 21 eliminates the need for the output buffer amp. These circuits approximate the function V_{IN}^M where M is the desired nonintegral power or root.

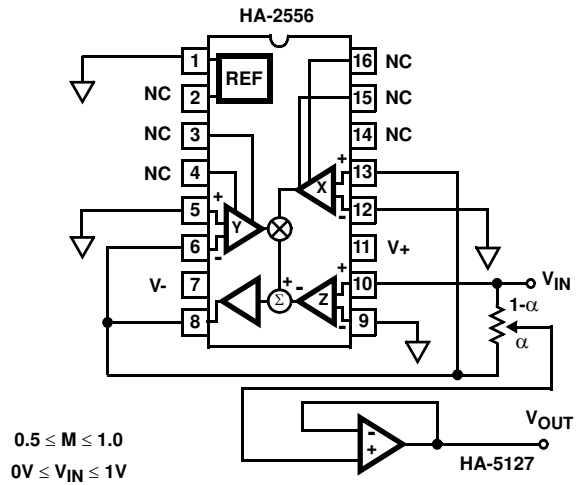

FIGURE 19. NONINTEGRAL ROOTS - ADJUSTABLE

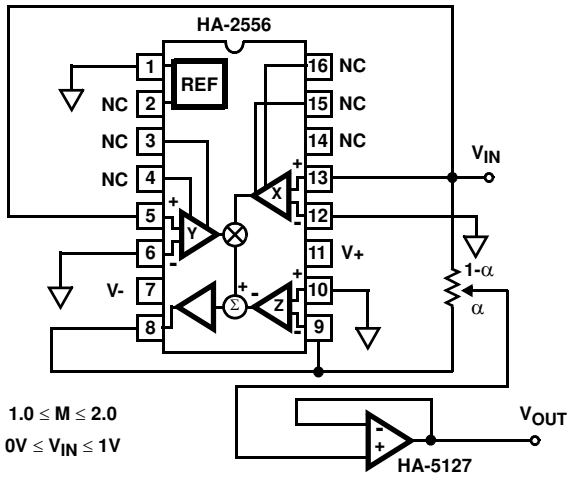

FIGURE 20. NONINTEGRAL POWERS - ADJUSTABLE

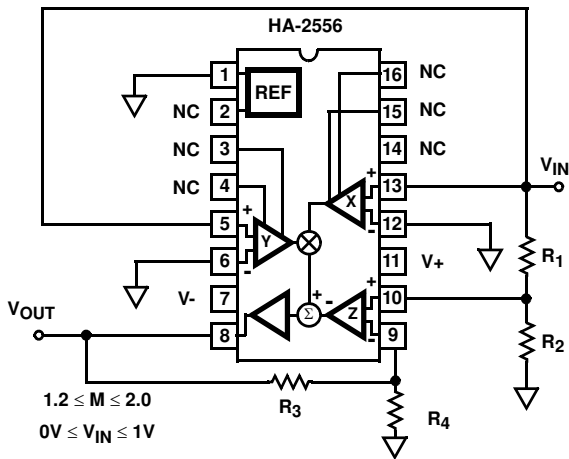

FIGURE 21. NONINTEGRAL POWERS - FIXED

$$V_{OUT} = \frac{1}{5} \left(\frac{R_3}{R_4} + 1 \right) V_{IN}^2 + \left(\frac{R_3}{R_4} + 1 \right) \left(\frac{R_2}{R_1 + R_2} \right) V_{IN} \quad (\text{EQ. 21})$$

Setting:

$$1 - \alpha = \frac{1}{5} \left(\frac{R_3}{R_4} + 1 \right) \quad \alpha = \left(\frac{R_3}{R_4} + 1 \right) \left(\frac{R_2}{R_1 + R_2} \right) \quad (\text{EQ. 22})$$

Values for α to give a desired M root or power are as follows:

ROOTS - FIGURE 19		POWERS - FIGURE 20	
M	α	M	α
0.5	0	1.0	1
0.6	≈0.25	1.2	≈0.75
0.7	≈0.50	1.4	≈0.50
0.8	≈0.70	1.6	≈0.30
0.9	≈0.85	1.8	≈0.15
1.0	1	2.0	0

Sine Function Generators

Similar functions can be formulated to approximate a SINE function converter as shown in Figure 22. With a linearly changing (0V to 5V) input the output will follow 0° to 90° of a sine function (0V to 5V) output. This configuration is theoretically capable of ±2.1% maximum error to full scale.

By adding a second HA-2556 to the circuit an improved fit may be achieved with a theoretical maximum error of ±0.5% as shown in Figure 23. Figure 23 has the added benefit that it will work for positive and negative input signals. This makes a convenient triangle (±5V input) to sine wave (±5V output) converter.

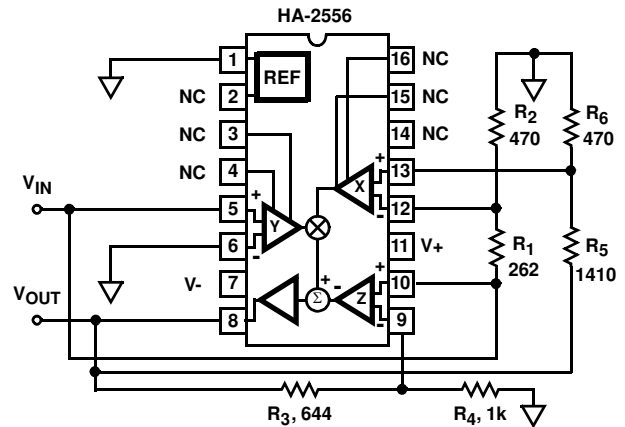

FIGURE 22. SINE-FUNCTION GENERATOR

References

- [1] Pacifico Cofrancesco, "RF Mixers and Modulators made with a Monolithic Four-Quadrant Multiplier" Microwave Journal, December 1991 pg. 58 - 70.
- [2] Richard Goller, "IC Generates Nonintegral Roots" Electronic Design, December 3, 1992.

$$V_{OUT} = V_{IN} \frac{(1 - 0.1284 V_{IN})}{(0.6082 - 0.05 V_{IN})} \approx 5 \sin\left(\frac{\pi}{2} \cdot \frac{V_{IN}}{5}\right) \quad (\text{EQ. 23})$$

for; $0V \leq V_{IN} \leq 5V$ Max Theoretical Error = 2.1%FS where:

$$0.6082 = \frac{R_4}{R_3 + R_4}; \quad 5(0.1284) = \frac{R_2}{R_1 + R_2} \quad (\text{EQ. 24})$$

$$5(0.05) = \frac{R_6}{R_5 + R_6}$$

$$V_{OUT} = \frac{5V_{IN} - 0.05494V_{IN}^3}{3.18167 + 0.0177919V_{IN}^2} \approx 5 \sin\left(\frac{\pi}{2} \cdot \frac{V_{IN}}{5}\right) \quad (\text{EQ. 25})$$

for; $-5V \leq V_{IN} \leq 5V$ Max Theoretical Error = 0.5%FS

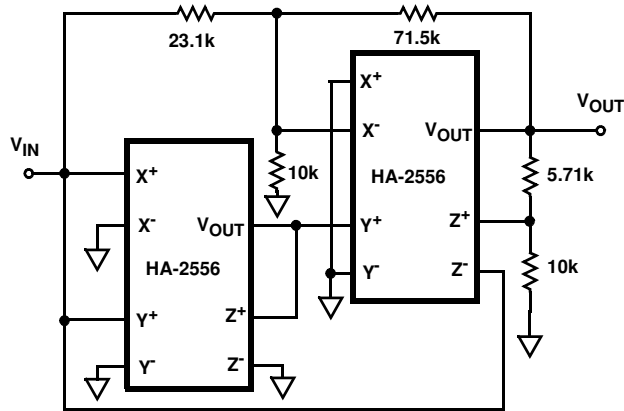

FIGURE 23. BIPOLAR SINE-FUNCTION GENERATOR

Typical Performance Curves

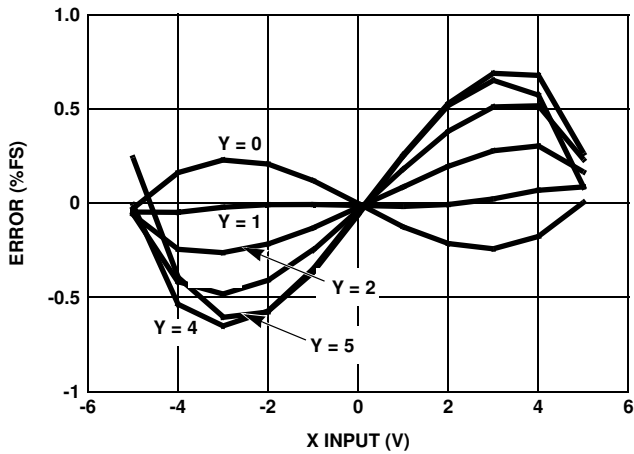

FIGURE 24. X-CHANNEL MULTIPLIER ERROR

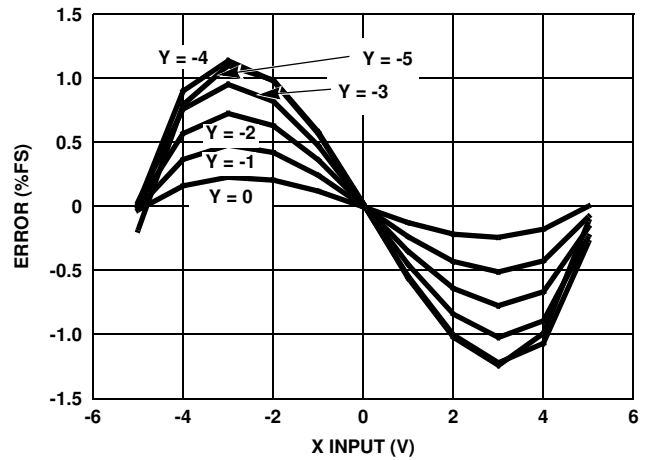

FIGURE 25. X-CHANNEL MULTIPLIER ERROR

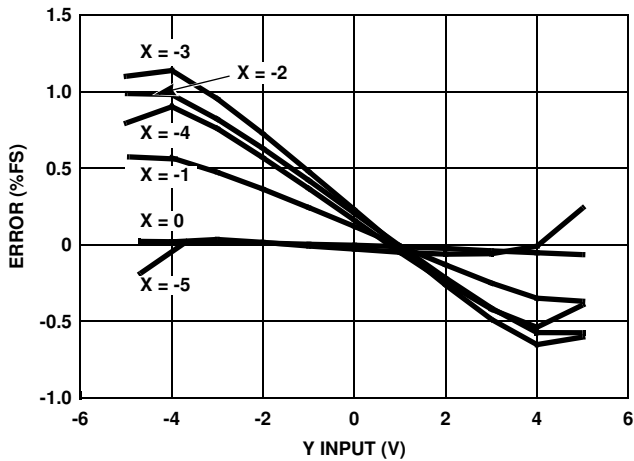

FIGURE 26. Y-CHANNEL MULTIPLIER ERROR

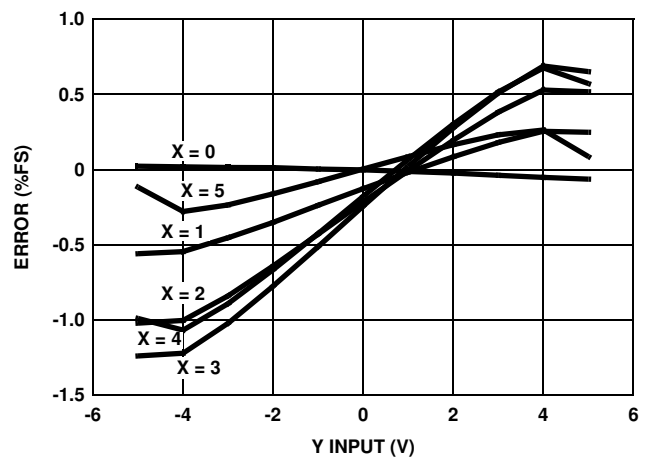

FIGURE 27. Y-CHANNEL MULTIPLIER ERROR

Typical Performance Curves (Continued)

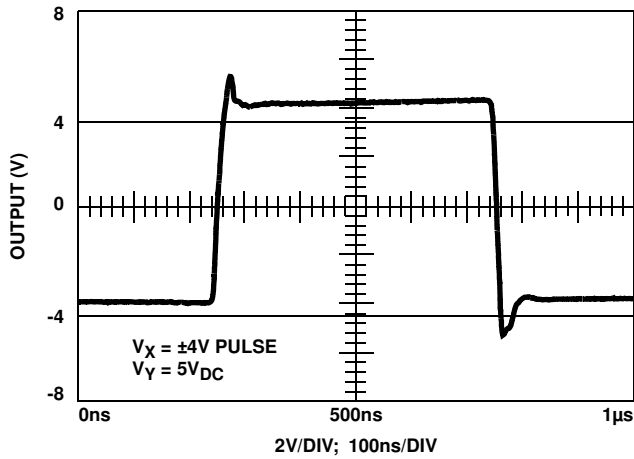

FIGURE 28. LARGE SIGNAL RESPONSE

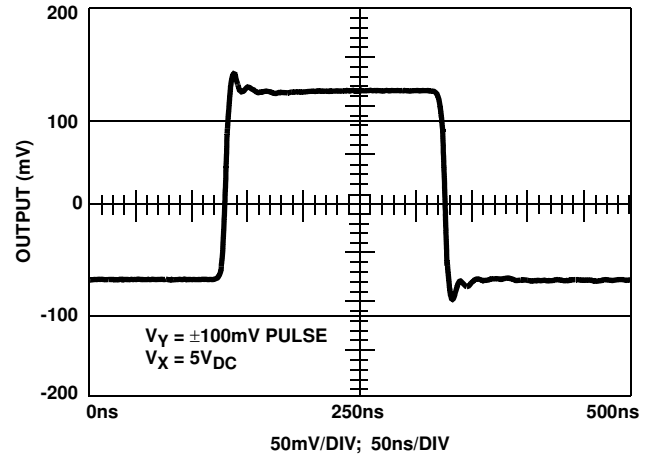

FIGURE 29. SMALL SIGNAL RESPONSE

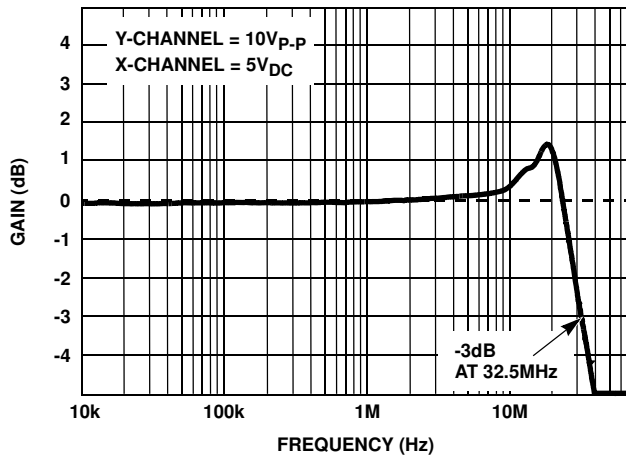

FIGURE 30. Y-CHANNEL FULL POWER BANDWIDTH

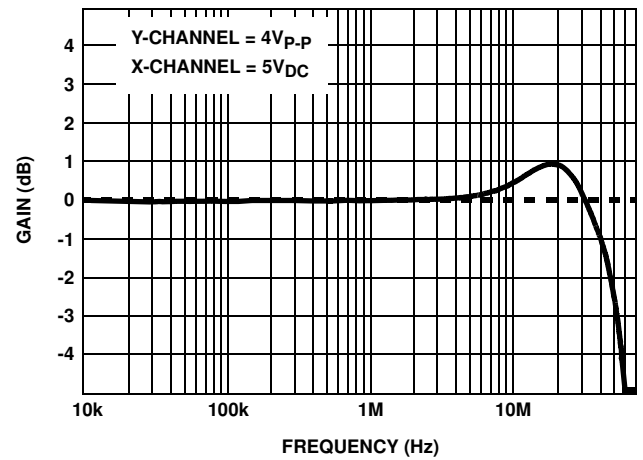

FIGURE 31. Y-CHANNEL FULL POWER BANDWIDTH

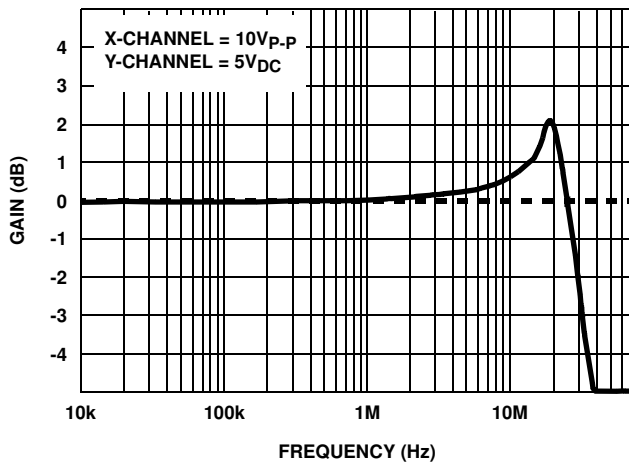

FIGURE 32. X-CHANNEL FULL POWER BANDWIDTH

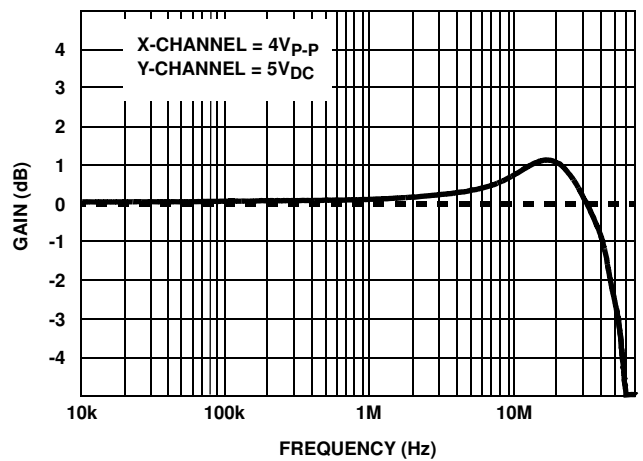

FIGURE 33. X-CHANNEL FULL POWER BANDWIDTH

Typical Performance Curves (Continued)

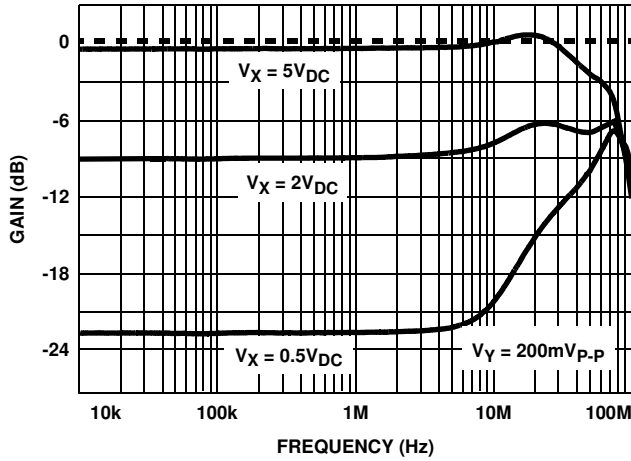

FIGURE 34. Y-CHANNEL BANDWIDTH vs X-CHANNEL

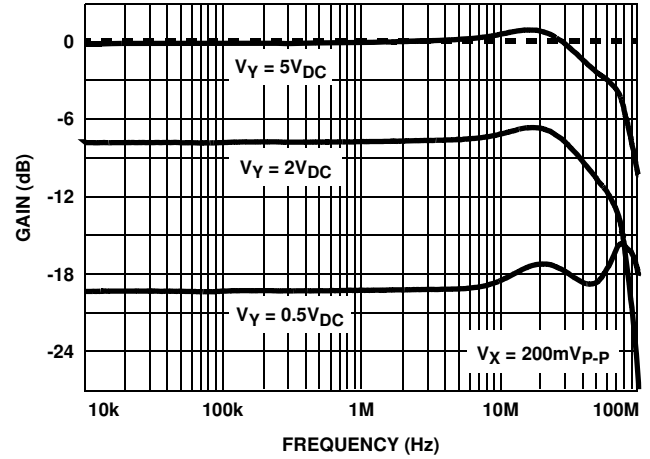

FIGURE 35. X-CHANNEL BANDWIDTH vs Y-CHANNEL

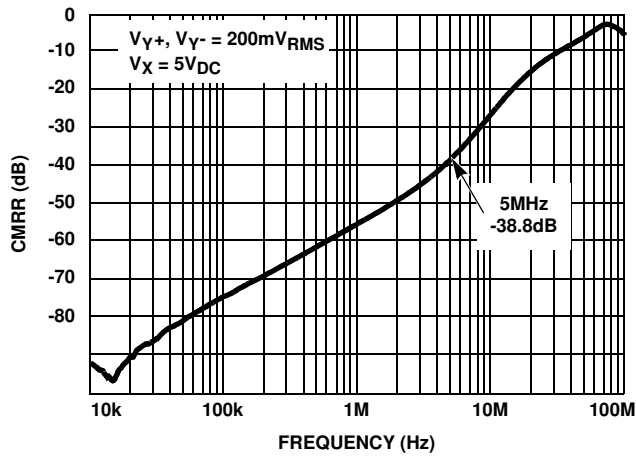

FIGURE 36. Y-CHANNEL CMRR vs FREQUENCY

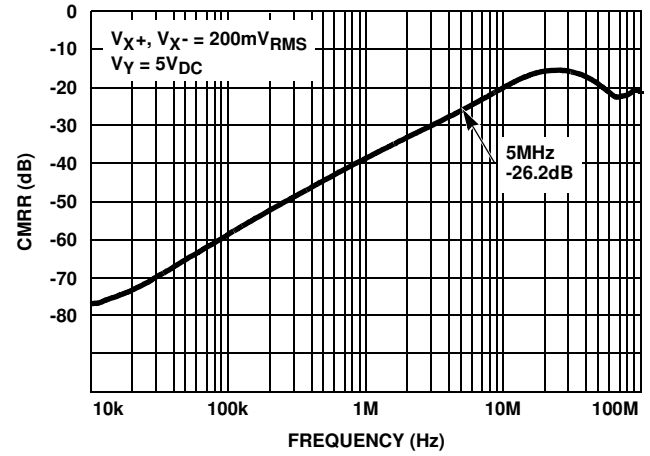

FIGURE 37. X-CHANNEL CMRR vs FREQUENCY

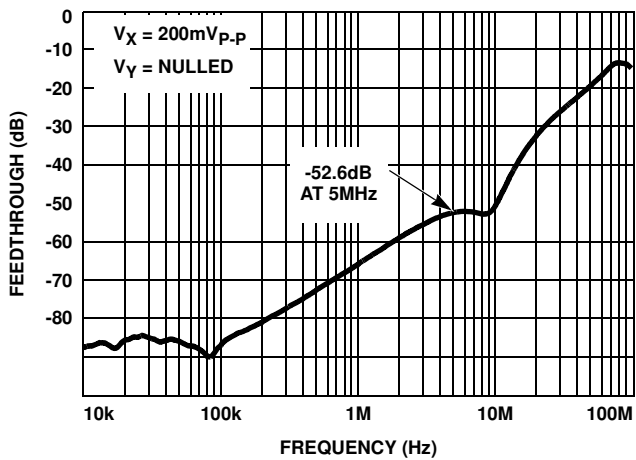

FIGURE 38. FEEDTHROUGH vs FREQUENCY

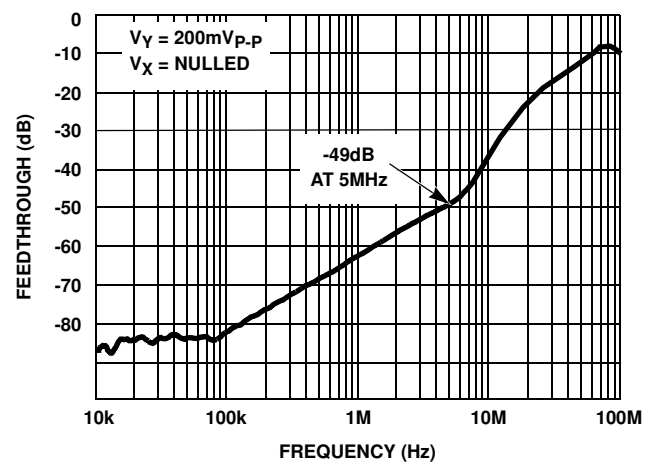

FIGURE 39. FEEDTHROUGH vs FREQUENCY

Typical Performance Curves (Continued)

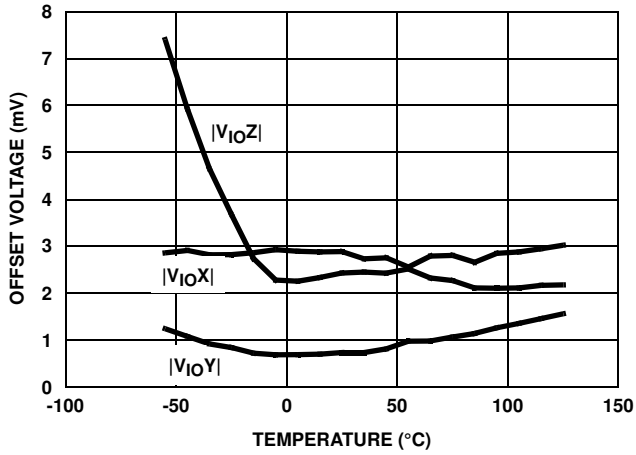

FIGURE 40. OFFSET VOLTAGE vs TEMPERATURE

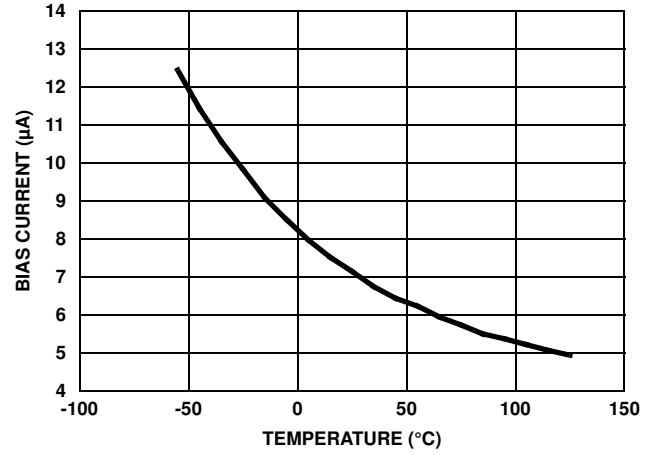

FIGURE 41. INPUT BIAS CURRENT (V_X , V_Y , V_Z) vs TEMPERATURE

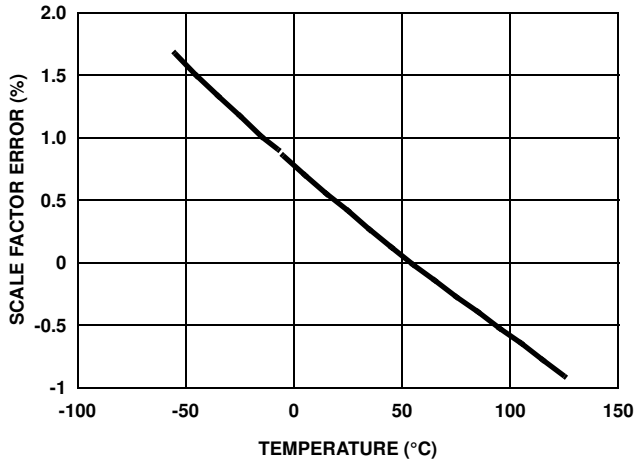

FIGURE 42. SCALE FACTOR ERROR vs TEMPERATURE

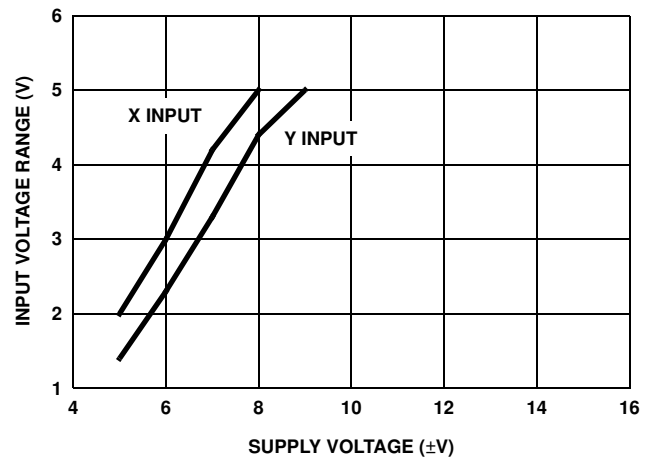

FIGURE 43. INPUT VOLTAGE RANGE vs SUPPLY VOLTAGE

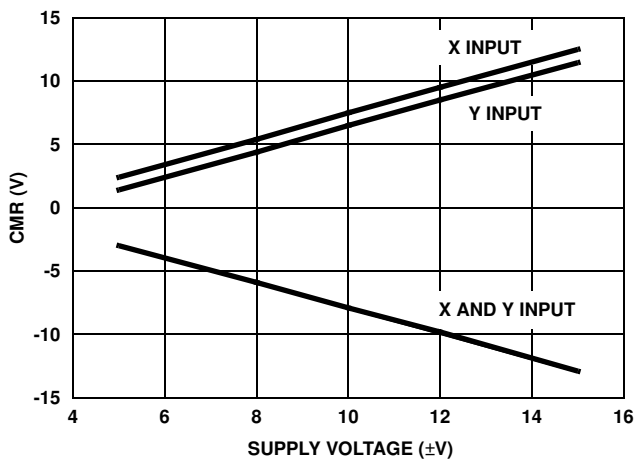

FIGURE 44. INPUT COMMON MODE RANGE vs SUPPLY VOLTAGE

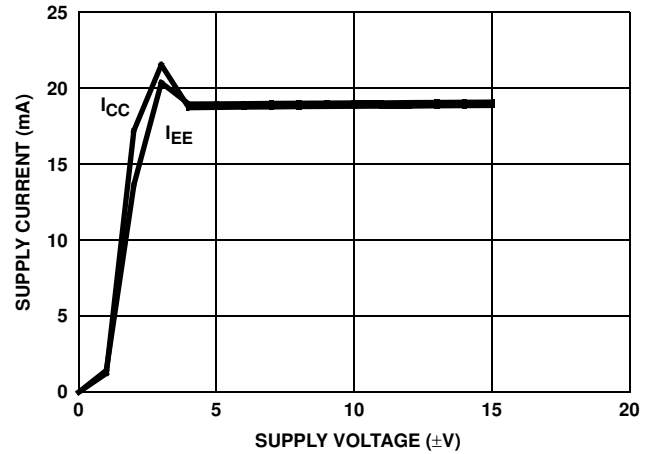

FIGURE 45. SUPPLY CURRENT vs SUPPLY VOLTAGE

Typical Performance Curves (Continued)

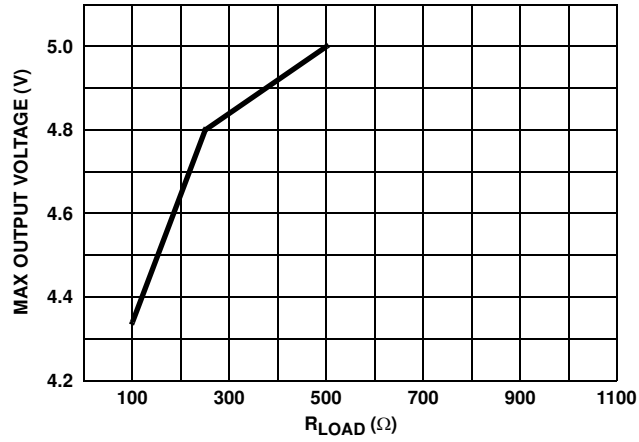

FIGURE 46. OUTPUT VOLTAGE vs R_{LOAD}

Die Characteristics

DIE DIMENSIONS:

71 mils x 100 mils x 19 mils

METALLIZATION:

Type: Al, 1% Cu
 Thickness: $16\text{k}\text{\AA} \pm 2\text{k}\text{\AA}$

PASSIVATION:

Type: Nitride (Si_3N_4) over Silox (SiO_2 , 5% Phos)
 Silox Thickness: $12\text{k}\text{\AA} \pm 2\text{k}\text{\AA}$
 Nitride Thickness: $3.5\text{k}\text{\AA} \pm 2\text{k}\text{\AA}$

TRANSISTOR COUNT:

84

SUBSTRATE POTENTIAL:

V-

Metallization Mask Layout

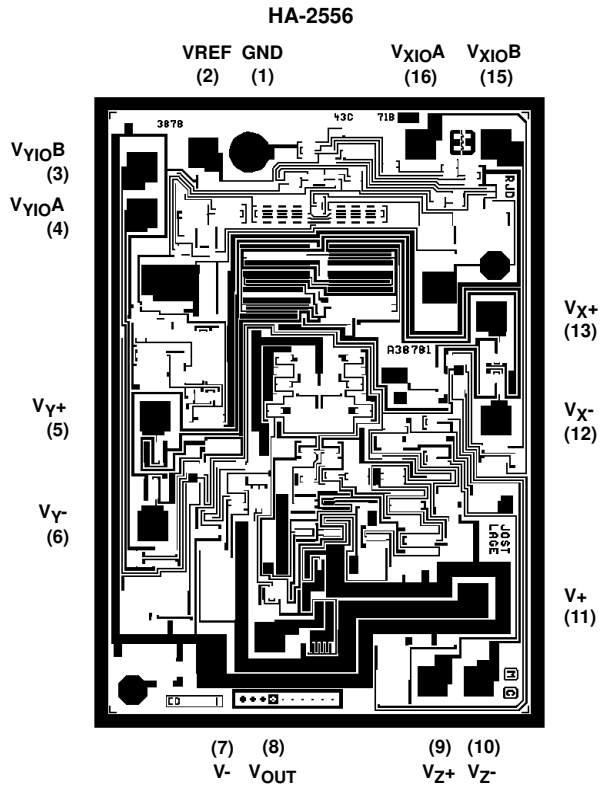

Small Outline Plastic Packages (SOIC)

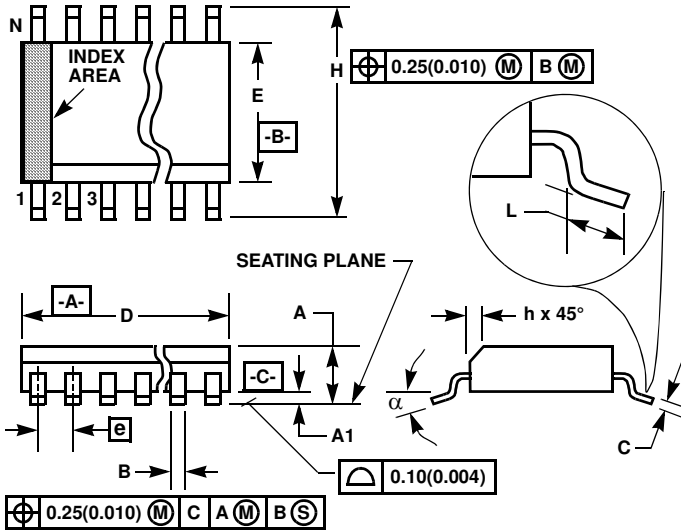

**M16.3 (JEDEC MS-013-AA ISSUE C)
16 LEAD WIDE BODY SMALL OUTLINE PLASTIC PACKAGE**

SYMBOL	INCHES		MILLIMETERS		NOTES
	MIN	MAX	MIN	MAX	
A	0.0926	0.1043	2.35	2.65	-
A1	0.0040	0.0118	0.10	0.30	-
B	0.013	0.0200	0.33	0.51	9
C	0.0091	0.0125	0.23	0.32	-
D	0.3977	0.4133	10.10	10.50	3
E	0.2914	0.2992	7.40	7.60	4
e	0.050 BSC		1.27 BSC		-
H	0.394	0.419	10.00	10.65	-
h	0.010	0.029	0.25	0.75	5
L	0.016	0.050	0.40	1.27	6
N	16		16		7
α	0°	8°	0°	8°	-

NOTES:

1. Symbols are defined in the "MO Series Symbol List" in Section 2.2 of Publication Number 95.
2. Dimensioning and tolerancing per ANSI Y14.5M-1982.
3. Dimension "D" does not include mold flash, protrusions or gate burrs. Mold flash, protrusion and gate burrs shall not exceed 0.15mm (0.006 inch) per side.
4. Dimension "E" does not include interlead flash or protrusions. Interlead flash and protrusions shall not exceed 0.25mm (0.010 inch) per side.
5. The chamfer on the body is optional. If it is not present, a visual index feature must be located within the crosshatched area.
6. "L" is the length of terminal for soldering to a substrate.
7. "N" is the number of terminal positions.
8. Terminal numbers are shown for reference only.
9. The lead width "B", as measured 0.36mm (0.014 inch) or greater above the seating plane, shall not exceed a maximum value of 0.61mm (0.024 inch)
10. Controlling dimension: MILLIMETER. Converted inch dimensions are not necessarily exact.

Rev. 1 6/05

For additional products, see www.intersil.com/en/products.html

Intersil products are manufactured, assembled and tested utilizing ISO9000 quality systems as noted in the quality certifications found at www.intersil.com/en/support/qualandreliability.html

Intersil products are sold by description only. Intersil Corporation reserves the right to make changes in circuit design, software and/or specifications at any time without notice. Accordingly, the reader is cautioned to verify that data sheets are current before placing orders. Information furnished by Intersil is believed to be accurate and reliable. However, no responsibility is assumed by Intersil or its subsidiaries for its use; nor for any infringements of patents or other rights of third parties which may result from its use. No license is granted by implication or otherwise under any patent or patent rights of Intersil or its subsidiaries.

For information regarding Intersil Corporation and its products, see www.intersil.com