



EV6005-K-00B

High Efficiency Flyback/Forward Controller Secondary-Side Regulate Forward EV Board

DESCRIPTION

EV6005-K-00B Evaluation Board is designed to demonstrate the capability of MP6005. The MP6005 is a high power, high efficiency flyback and forward controller. It is specifically designed for both low cost, small size isolated solution with primary-side regulate (PSR) flyback application, and high efficiency secondary-side regulate (SSR) active-clamped forward application. It also can be used in SSR flyback topology.

MP6005 senses the third winding waveform on primary side to regulate output in PSR mode, saves the traditional complex opto-isolator circuit. MP6005 can also be set as SSR mode, while the SYNC driver provides high efficiency solution for active-clamped forward topology.

The MP6005 also features with 2A GATE driver, frequency dithering, over load protection and over voltage protection.

The MP6005 is available in MSOP10 package.

Electrical Specification

Parameter	Symbol	Value	Units
Input Voltage	V _{IN}	36-57	V
Output Voltage	V _{OUT}	5	V
Output Current	I _{OUT}	4.8	A

FEATURES

- 36V to 57V Input Voltage Range
- 5V Output Voltage and 4.8A Output Current
- High Efficiency Active-clamped Forward Solution
- 250kHz Fixed Switching Frequency
- EMI Reduction with Frequency Dithering
- Auxiliary Winding Supply VCC to Save IC Loss
- 2A GATE and 0.8A SYNC Drivers
- 160mV Switching Current Sense Limit
- Hiccup Protection for OLP, SCP, OVP and Thermal Shutdown
- Available in MSOP10 Package

APPLICATIONS

- Security Camera
- Video Telephone
- Wireless AP
- POS System
- Industrial Isolated Power Supply

All MPS parts are lead-free, halogen free, and adhere to the RoHS directive. For MPS green status, please visit MPS website under Quality Assurance.

"MPS" and "The Future of Analog IC Technology" are Registered Trademarks of Monolithic Power Systems, Inc.

EV6005-K-00B EVALUATION BOARD



(L x W x H) 9cm x 3.5cm x 2cm

Board Number	MPS IC Number
EV6005-K-00B	MP6005GK

Efficiency vs. Load Current

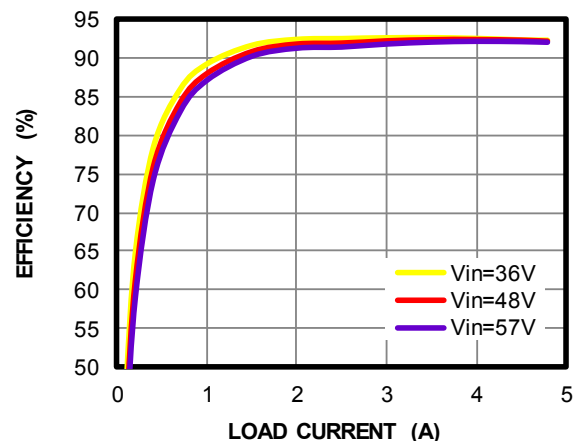

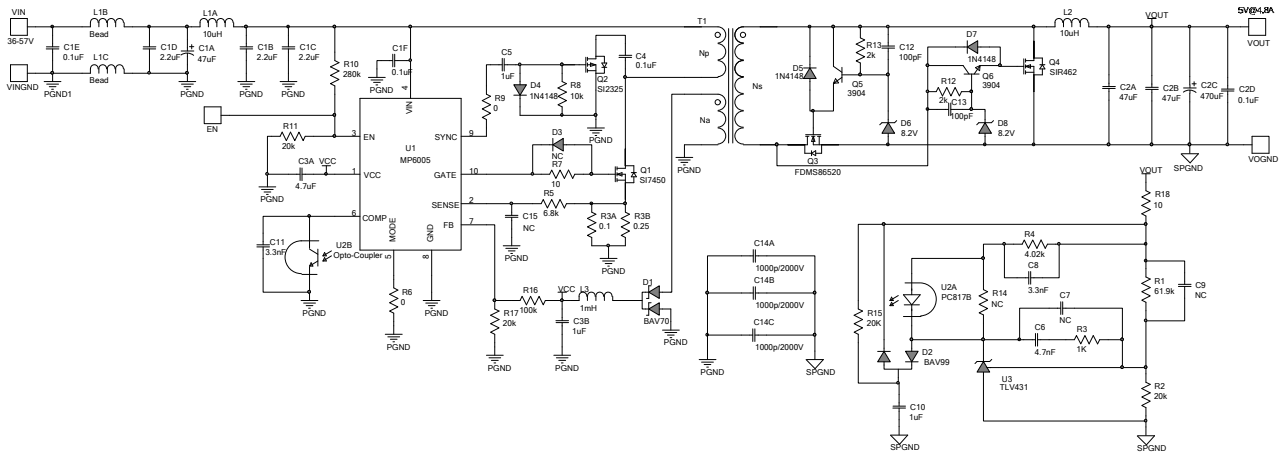
EVALUATION BOARD SCHEMATIC (1)

NOTE:

- EV6005-K-00B is setting in frequency dither mode for better EMI performance, if stable switch is needed, please set R5 lower than 1.3k.

BILL OF MATERIALS

Qty	Ref	Value	Description	Package	Manufacturer	Part Number
1	C1A	47μF	47μF E-cap	DIP	Jianghai	47μF/100V
3	C1B, C1C, C1D	2.2μF	Ceramic Cap.,100V,X7R	1210	muRata	GRM32ER72A225KA88L
1	C1E	0.1μF	Ceramic Cap.,100V,X7R	0805	muRata	GRM21BR72A104KA01D
1	C1F	0.1μF	Ceramic Cap.,100V,X7R	0603	muRata	GRM188R72A104KA01D
2	C2A, C2B	47μF	Ceramic Cap.,10V,X7R	1210	muRata	GRM32ER71A476KA88L
1	C2C	470μF	470μF E-cap	DIP	wurth	860080274011
1	C2D	0.1μF	Ceramic Cap.,25V,X7R	0603	muRata	GRM188R71E104KA01D
1	C3A	4.7μF	Ceramic Cap.,25V,X7R	0805	muRata	GRM21BR71E475KA01D
3	C3B, C5, C10	1μF	Ceramic Cap.,25V,X7R	0603	muRata	GRM188R71E105KA01D
1	C4	0.1μF	Ceramic Cap.,200V,X7R	1206	muRata	GRM31CR72D104KW03L
1	C6	4.7nF	Ceramic Cap.,16V,X7R	0603	muRata	GRM188R71C472KA01D
5	C7, C9, C15, R14, D3	NC				
2	C8, C11	3.3nF	Ceramic Cap.,16V,X7R	0603	muRata	GRM188R71C332KA01D
2	C12, C13	100pF	Ceramic Cap.,50V,X7R	0603	muRata	GRM188R71H101KA01D
3	C14A, C14B, C14C	1000p/2000V	Ceramic Cap.,2000V X7R	1808	muRata	GR442QR73D102KW01L
1	D1	BAV70	Series diodes	SOT-23	Fairchild	BAV70
1	D2	BAV99	Series diodes	SOT-23	Fairchild	BAV99
3	D4, D5, D7	1N4148	Diode Switch, 75V, 400mW	SOD-323	Diodes Inc.	1N4148W-7
2	D6, D8	8.2V	Diode Zener, 500mW, 8.2V	SOD-123	Diodes Inc.	BZT52C8V2-7
1	L1A	10μH	Isat=4.9A, Rdc=40.9mΩ	SMD	Coilcraft	XAL5050-103MEC

BILL OF MATERIALS (continued)

Qty	Ref	Value	Description	Package	Manufacturer	Part Number
2	L1B, L1C	600Ω	I _{rms} =3A, R _{dc} =42mΩ	1210	KEMET	Z1210C601BPWZT
1	L2	10μH	I _{sat} =9A, R _{dc} =15mΩ	SMD	Würth	744 332 100 0
1	L3	1mH	I _{sat} =0.1A, R _{dc} =16.4mΩ	SMD	Coilcraft	LPS4414-105MLC
1	Q1	SI7450	80mΩ 200V N-MOSFET	PowerPak SO-8	Vishy	SI7450DP
1	Q2	SI2325	1.3Ω 150V P-MOSFET	SOT-23	Vishy	SI2325DS
1	Q3	FDMS86520	7.4mΩ 60V N-MOSFET	PowerPAK SO-8	Fairchild	FDMS86520
1	Q4	SIR462	7.9mΩ 30V N-MOSFET	PowerPAK SO-8	Vishay	SiR462DP
2	Q5, Q6	3904	40V NPN	SOT-23	Fairchild	MMBT3904
1	R1	61.9k	Film Res., 1%	0603	ROYAL	RC0603FR-0761K9L
4	R2, R11, R15, R17	20k	Film Res., 1%	0603	ROYAL	RC0603FR-0720KL
1	R3	1k	Film Res., 1%	0603	ROYAL	RC0603FR-071KL
1	R3A	0.1	Film Res., 1%	1206	ROYAL	RC1206FR-070R1L
1	R3B	0.25	Film Res., 1%	1206	ROYAL	RC1206FR-070R25L
1	R4	4.02k	Film Res., 1%	0603	ROYAL	RC0603FR-074K02L
1	R5	6.8k	Film Res., 1%	0603	ROYAL	RC0603FR-076k8L
2	R6, R9	0	Film Res., 1%	0603	ROYAL	RC0603FR-070RL
2	R7, R18	10	Film Res., 1%	0603	ROYAL	RC0603FR-0710RL
1	R8	10k	Film Res., 1%	0603	ROYAL	RC0603FR-0710KL
1	R10	280k	Film Res., 1%	0603	ROYAL	RC0603FR-07280KL
2	R12, R13	2k	Film Res., 1%	1206	ROYAL	RC1206FR-072KL
1	R16	100k	Film Res., 1%	0603	ROYAL	RC0603FR-07100KL
1	T1	FCT1-50M22SL	Forward transformer	EP13	Coilcraft	FCT1-50M22SL
1	U1	MP6005GK	Fly-back/Forward controller	MSOP10	MPS	MP6005GK
1	U2	PC357	Opto-coupler	4-pin Mini-flat	SHARP	PC357
1	U3	TLV431	1.24V regulator	SOT-23	NXP	TLVH431DMQDBZR

EVB TEST RESULTS

$V_{IN} = 48V$, $V_{OUT} = 5V$, $I_{OUT} = 4.8A$, $T_A = 25^\circ C$, unless otherwise noted.

Efficiency vs. Load Current

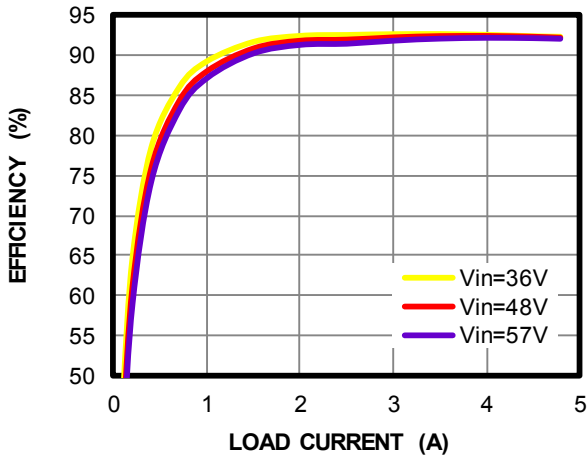

Load Regulation vs. Load Current

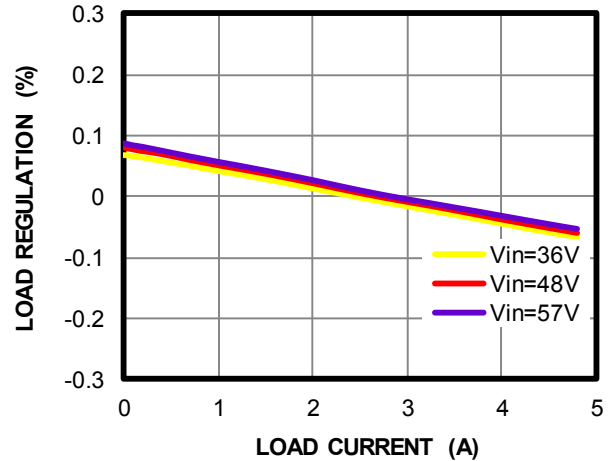

Line Regulation vs. Input Voltage

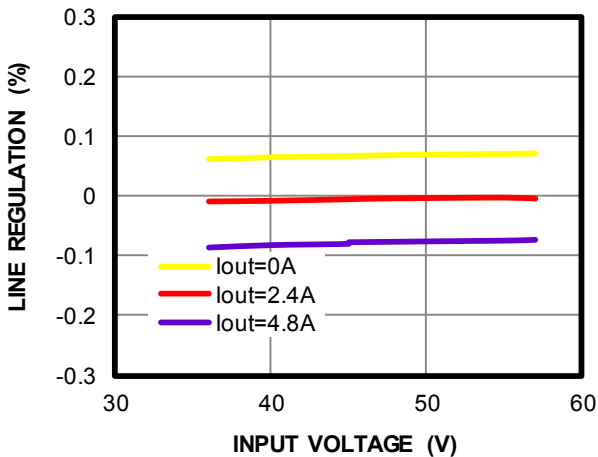

Bode Plot

$I_{OUT} = 4.8A$

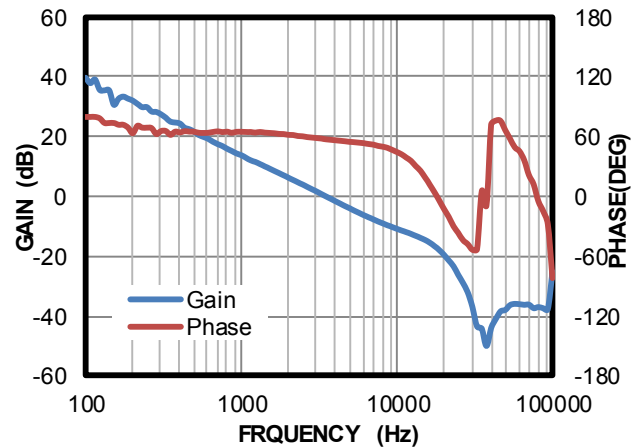

Radiated Emission Results

$I_{OUT} = 4.8A$

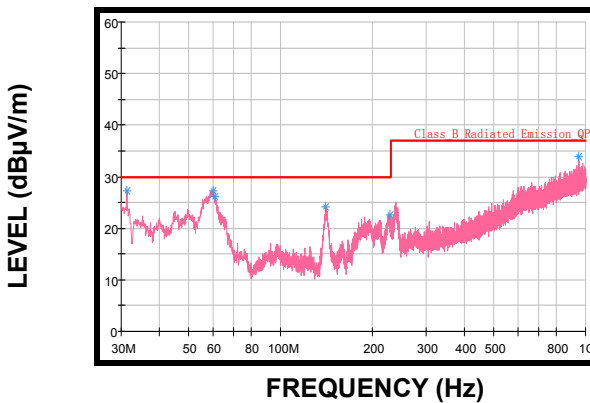

Conducted Emission Results

$I_{OUT} = 4.8A$

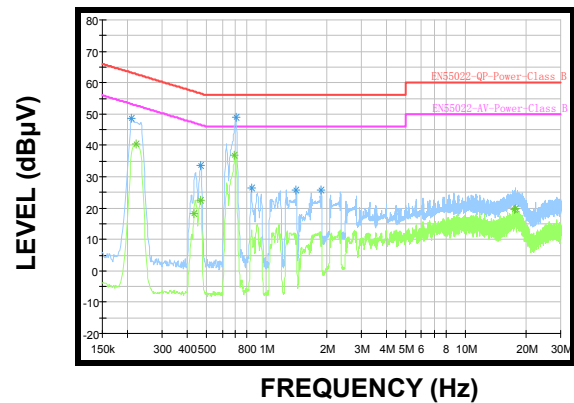

EVB TEST RESULTS (continued)

$V_{IN} = 48V$, $V_{OUT} = 5V$, $I_{OUT} = 4.8A$, $T_A = 25^{\circ}C$, unless otherwise noted.

Steady State

$I_{OUT} = 0A$

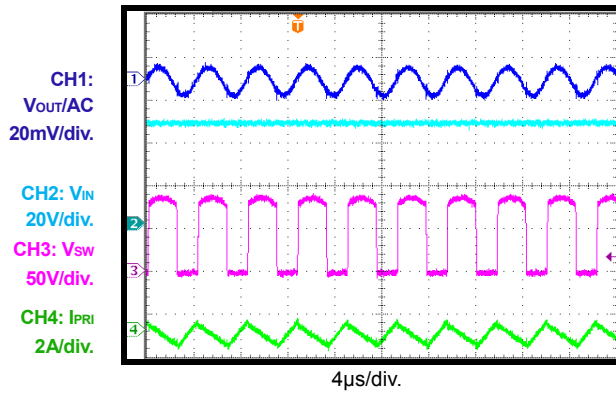

Steady State

$I_{OUT} = 4.8A$

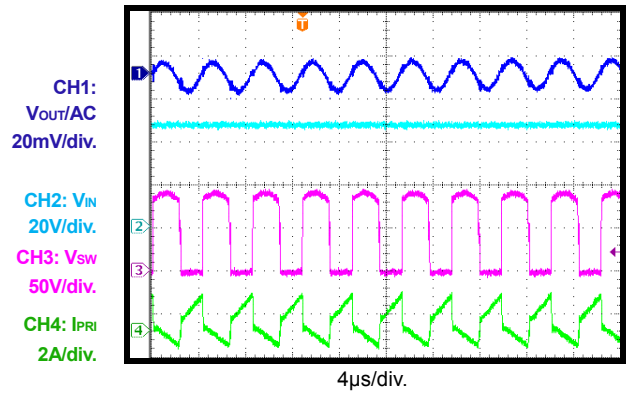

VIN Start-Up

$I_{OUT} = 0A$

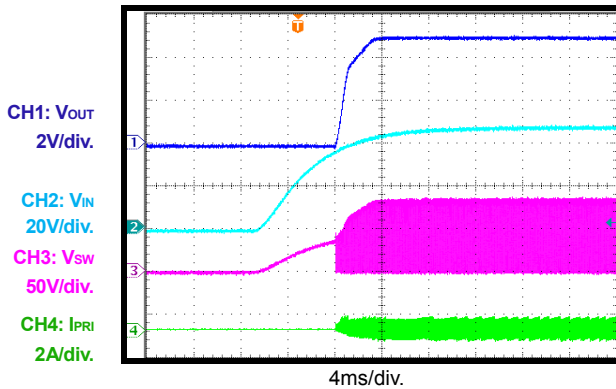

VIN Start-Up

$I_{OUT} = 4.8A$

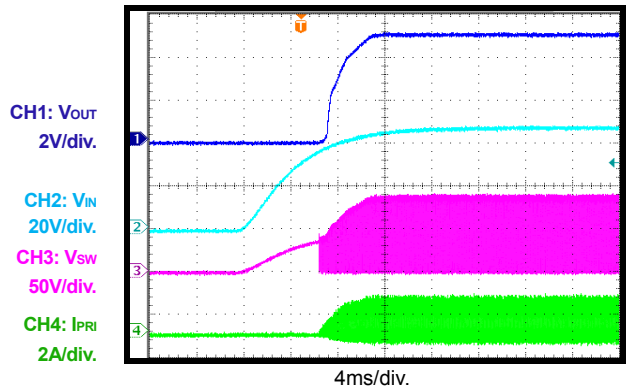

VIN Shutdown

$I_{OUT} = 0A$

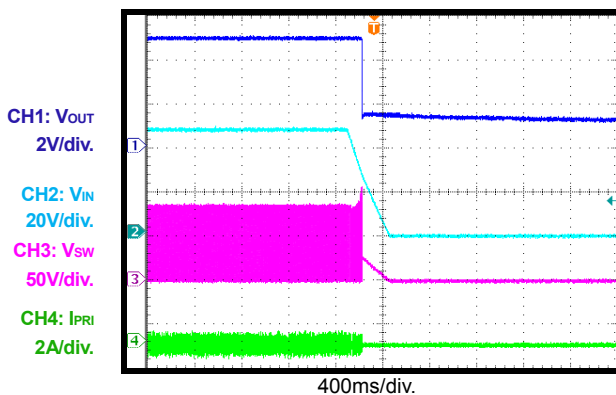

VIN Shutdown

$I_{OUT} = 4.8A$

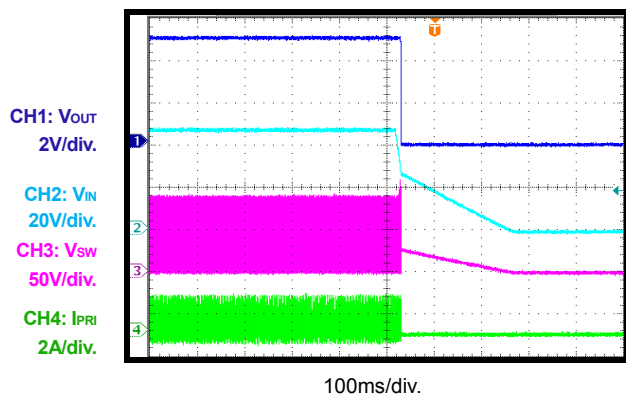

EVB TEST RESULTS (continued)

$V_{IN} = 48V$, $V_{OUT} = 5V$, $I_{OUT} = 4.8A$, $T_A = 25^{\circ}C$, unless otherwise noted.

EN Start-Up

$I_{OUT} = 0A$

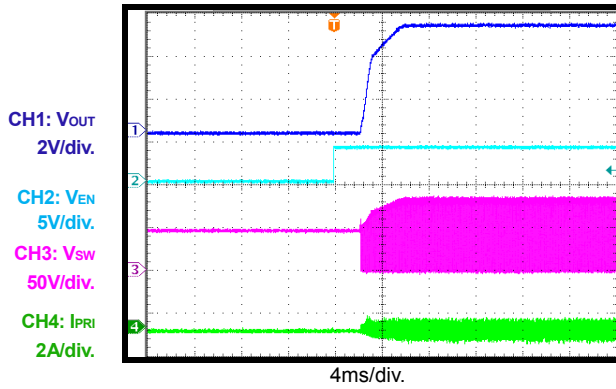

EN Start-Up

$I_{OUT} = 4.8A$

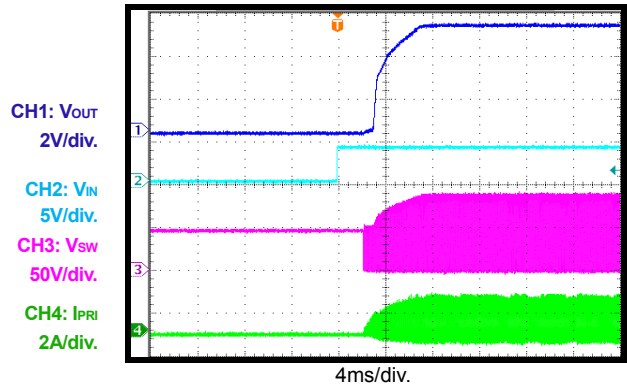

EN Shutdown

$I_{OUT} = 0A$

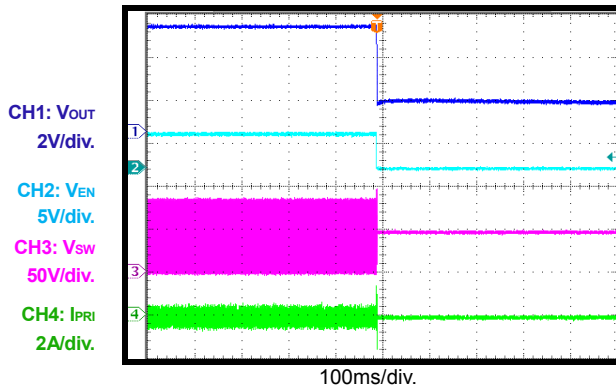

EN Shutdown

$I_{OUT} = 4.8A$

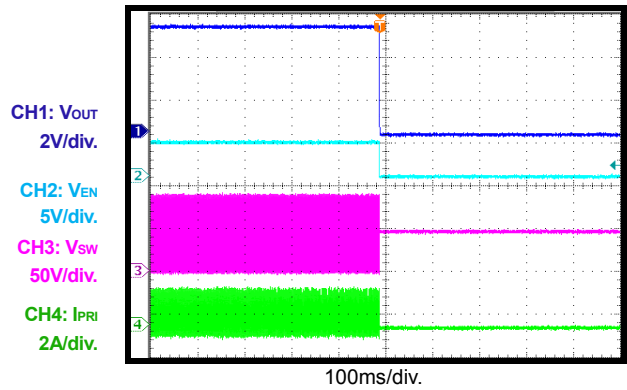

SCP Entry

$I_{OUT} = 0A$ to Short

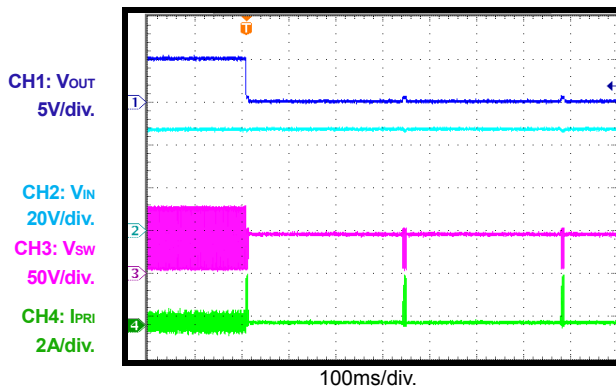

SCP Entry

$I_{OUT} = 4.8A$ to Short

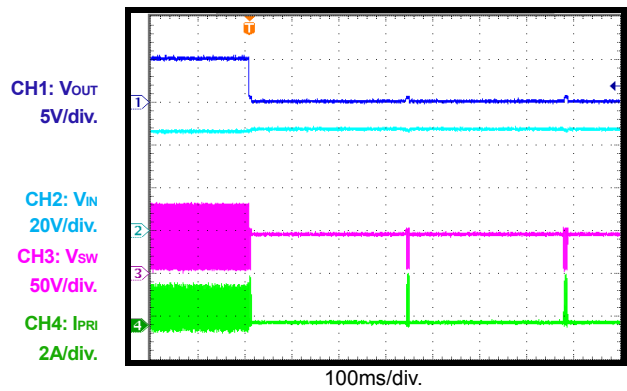

EVB TEST RESULTS *(continued)*

$V_{IN} = 48V$, $V_{OUT} = 5V$, $I_{OUT} = 4.8A$, $T_A = 25^{\circ}C$, unless otherwise noted.

SCP Recovery

$I_{OUT} = \text{Short to } 0A$

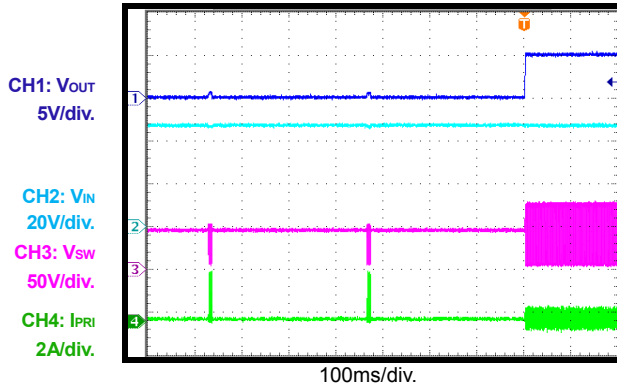

SCP Recovery

$I_{OUT} = \text{Short to } 4.8A$

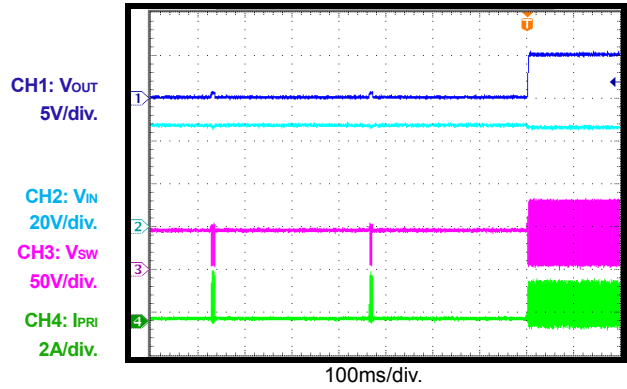

Load Transient

$I_{OUT} = 0A - 2.4A$, $I_{RAMP} = 25mA/\mu s$

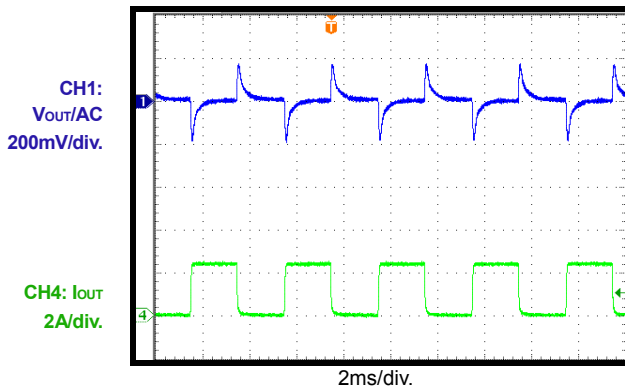

Load Transient

$I_{OUT} = 2.4A - 4.8A$, $I_{RAMP} = 25mA/\mu s$

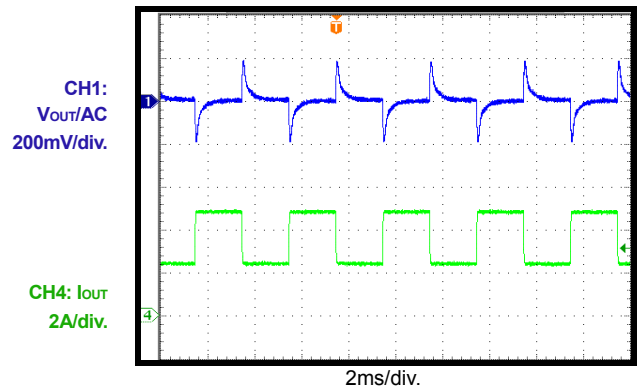

PRINTED CIRCUIT BOARD LAYOUT

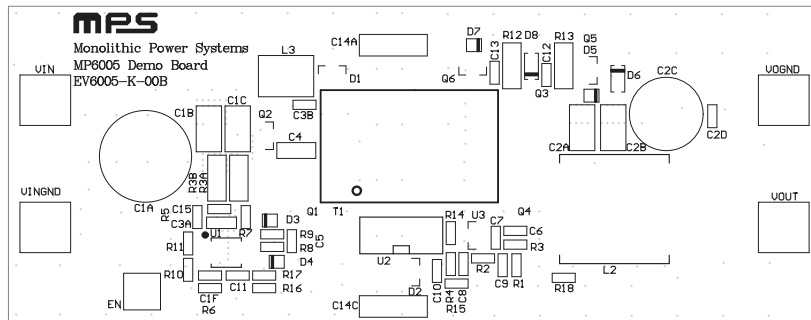

Figure 1: Top Silk Layer

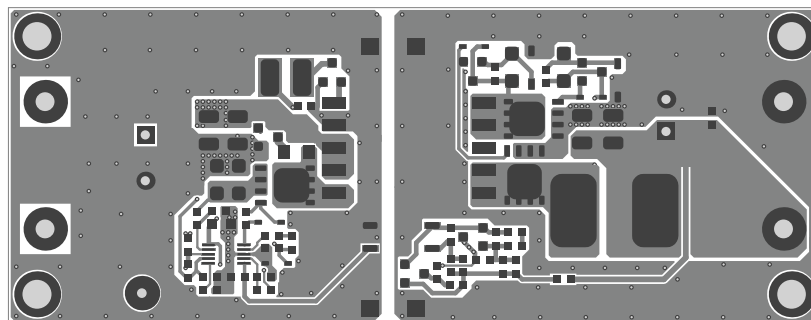

Figure 2: Top Layer

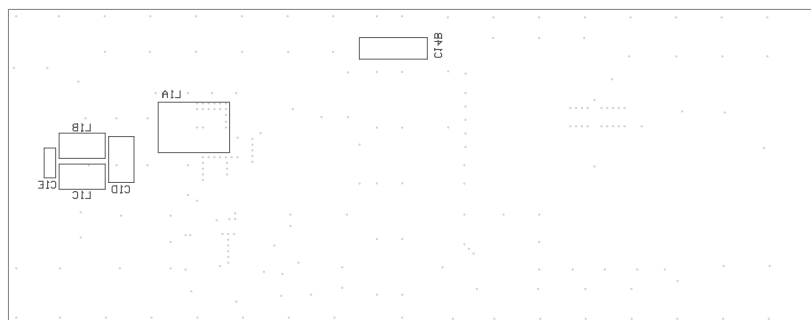

Figure 3: Bottom Silk Layer

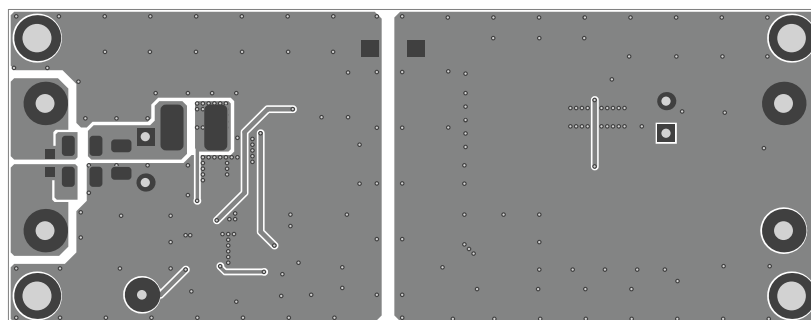

Figure 4: Bottom Layer

QUICK START GUIDE

The output voltage of this board is set to 5V. The board layout accommodates most commonly used components. Following below steps to quick start EV6005-K-00B.

1. Preset Power Supply to $36V \leq V_{IN} \leq 57V$.
2. Turn Power Supply off.
3. Connect Power Supply terminals to:
 - a. Positive (+): VIN
 - b. Negative (-): VINGND
4. Connect Load to:
 - a. Positive (+): VOUT
 - b. Negative (-): VOGND
5. Turn Power Supply on after making connections. The MP6005 will automatically startup.

NOTICE: The information in this document is subject to change without notice. Please contact MPS for current specifications. Users should warrant and guarantee that third party Intellectual Property rights are not infringed upon when integrating MPS products into any application. MPS will not assume any legal responsibility for any said applications.