

DATA SHEET

SKY65132: WLAN Power Amplifier Module

Applications

- IEEE802.11 b/g WLAN
- ISM band
- WCS fixed wireless
- Wireless access nodes

Features

- Single 3.3 V supply
- Linear output power of +29 dBm for IEEE802.11b mask
- Linear output power of +27 dBm for IEEE802.11g mask
- High gain of 33 dB
- Output power detector: 20 dB dynamic range
- Superior gain flatness
- Internal RF match and bias circuits
- Small footprint, MCM (20-pin, 6 x 6 mm) Pb-free (MSL3, 250 °C per JEDEC J-STD-020) SMT package

NEW Skyworks offers lead (Pb)-free, RoHS (Restriction of Hazardous Substances) compliant packaging.



Description

Skyworks SKY65132 is a Microwave Monolithic Integrated Circuit (MMIC) Power Amplifier (PA) with superior output power, linearity, and efficiency. These features make the SKY65132 ideal for Wireless Local Area Network (WLAN) applications.

The device is fabricated using Skyworks high reliability Indium Gallium Phosphide (InGaP) Heterojunction Bipolar Transistor (HBT) technology. The device is internally matched and mounted in a 20-pin, 6 x 6 mm Multi-Chip Module (MCM) Surface-Mounted Technology (SMT) package, which allows for a highly manufacturable low cost solution.

The device package and pinout for the 20-pin MCM are shown in Figure 1. A block diagram of the SKY65132 is shown in Figure 2.

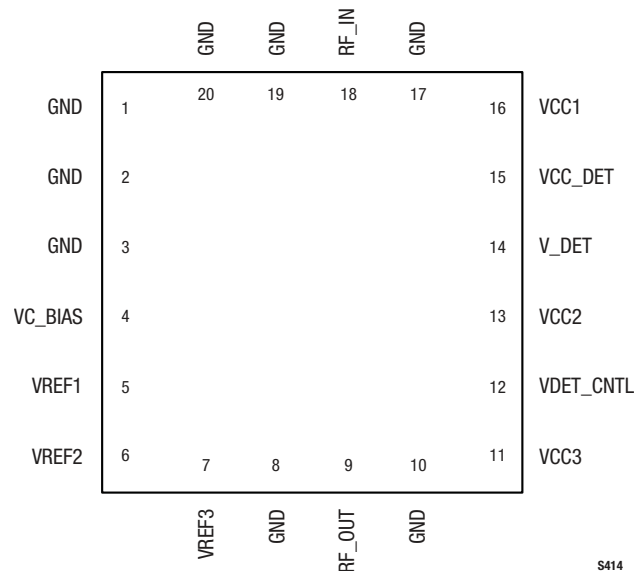

Figure 1. SKY65132 Pinout – 20-Pin MCM (Top View)

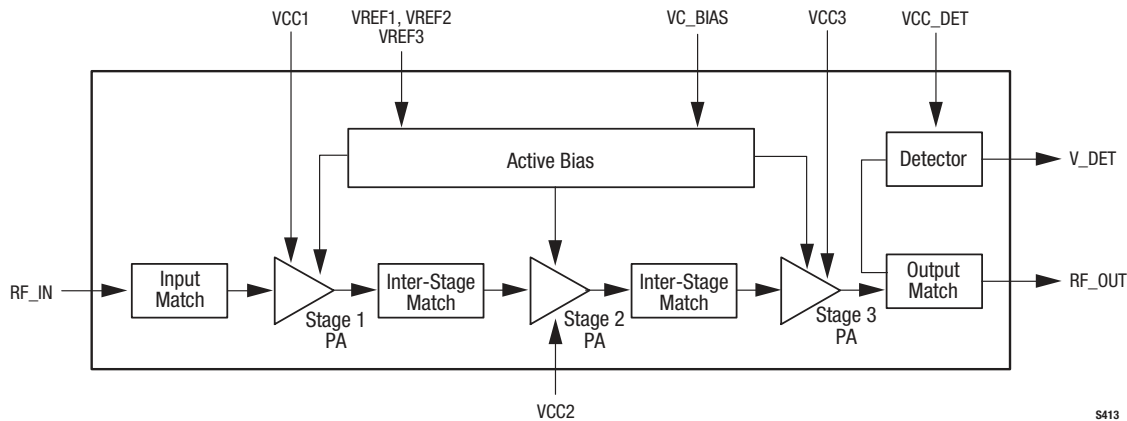

Figure 2. SKY65132 Block Diagram

Technical Description

The SKY65132 PA contains all of the needed RF matching and DC biasing circuits. The device also provides an output power detector voltage.

The SKY65132 is a three-stage, HBT InGaP device optimized for high linearity and power efficiency. These features make the device suitable for wideband digital applications, where PA linearity and power consumption are of critical importance (e.g., WLANs).

The device has been characterized with the highest specified data rates for 802.11b (11 Mbps) and 802.11g (54 Mbps). Under these stringent test conditions, the device exhibits excellent spectral purity and power efficiency.

Package and Handling Information

Since the device package is sensitive to moisture absorption, it is baked and vacuum packed before shipping. Instructions on the shipping container label regarding exposure to moisture after the container seal is broken must be followed. Otherwise, problems related to moisture absorption may occur when the part is subjected to high temperature during solder assembly.

The SKY65132 is rated to Moisture Sensitivity Level 3 (MSL3) at 250 °C. It can be used for lead or lead-free soldering. For additional information, refer to Skyworks Application Note, *PCB Design and SMT Assembly/Rework Guidelines for MCM-L Packages*, document number 101752.

Care must be taken when attaching this product, whether it is done manually or in a production solder reflow environment. Production quantities of this product are shipped in a standard tape and reel format. For packaging details, refer to the Skyworks Application Note, *Tape and Reel*, document number 101568.

Electrical and Mechanical Specifications

Signal pin assignments and functional pin descriptions are described in Table 1. The absolute maximum ratings of the SKY65132 are provided in Table 2. Electrical specifications are provided in Table 3.

Typical performance characteristics are shown in Figures 3 through 10. Figure 11 provides a typical evaluation board schematic. The evaluation board assembly drawing is provided in Figure 12. The evaluation board layer detail is shown in Figure 13 and the layer detail physical characteristics in Figure 14. Package dimensions for the SKY65132 20-pin MCM are shown in Figure 15, and tape and reel dimensions are shown in Figure 16.

Electrostatic Discharge (ESD) Sensitivity

The SKY65132 is a static-sensitive electronic device. Do not operate or store near strong electrostatic fields. Take proper ESD precautions.

Table 1. SKY65132 Signal Descriptions

Pin #	Name	Description	Pin #	Name	Description
1	GND	Ground	11	VCC3	Stage 3 collector voltage
2	GND	Ground	12	VDET_CNTL	Detector voltage control
3	GND	Ground	13	VCC2	Stage 2 collector voltage
4	VC_BIAS	Bias voltage	14	V_DET	Detector output signal
5	VREF1	Bias reference voltage 1	15	VCC_DET	Detector supply voltage
6	VREF2	Bias reference voltage 2	16	VCC1	Stage 1 collector voltage
7	VREF3	Bias reference voltage 3	17	GND	Ground
8	GND	Ground	18	RF_IN	RF input
9	RF_OUT	RF output	19	GND	Ground
10	GND	Ground	20	GND	Ground

Table 2. SKY65132 Absolute Maximum Ratings

Parameter	Symbol	Minimum	Maximum	Units
RF output power	P _{OUT}		30	dBm
Supply voltage	VC_BIAS, VREF1, VREF2, VREF3, VCC1, VCC2, VCC3, and VCC_DET		5	V
Supply current (I _b + I _{BIAS})	I _{CC}		1100	mA
Power dissipation			4.0	W
Case operating temperature	T _C	-40	+85	°C
Storage temperature	T _{ST}	-55	+125	°C
Junction temperature	T _J		+150	°C

Note: Exposure to maximum rating conditions for extended periods may reduce device reliability. There is no damage to device with only one parameter set at the limit and all other parameters set at or below their nominal value.

Table 3. SKY65132 Recommended Operating Conditions

Parameter	Symbol	Minimum	Typical	Maximum	Units
RF output power	P _{OUT}		27	29	dBm
Supply voltage	VC_BIAS, VREF1, VREF2, VREF3, VCC1, VCC2, VCC3, and VCC_DET	3.0	3.3	3.6	V
Case operating temperature	T _C	-40		+85	°C
Storage temperature	T _{ST}	-55		+125	°C

Table 4. SKY65132 Electrical Specifications
(VCC = 3.3 V, Tc = +25 °C, Test Frequency = 2.442 GHz unless otherwise noted)

Parameter	Symbol	Test Condition	Min	Typical	Max	Units
Using IEEE802.11b Complimentary Code Keying Input Signal, Data Rate = 11 Mbps						
Supply current	I _{cc}			950		mA
Output power (Note 1)	P _{OUT}			29		dBm
Power added efficiency (Note 2)	PAE			20		%
Ramp-up/ramp-down (Note 3)	T _s			<0.5		μs
Using IEEE802.11g Orthogonal Frequency Division Multiplexing Input Signal, Data Rate = 54 Mbps						
Supply current	I _{cc}			750		mA
Output power (Note 4)	P _{OUT}			27		dBm
Power added efficiency (Note 2)	PAE			18		%
Using Continuous Wave Input Signals						
Small signal gain	G	Continuous wave	31.5	33.0		dB
Gain flatness over band		From 2.4 GHz to 2.5 GHz		±1.0		dB
Gain flatness over channel (16.25 MHz)		Over any 16.25 MHz within band		±0.4		dB
Output power @ 1 dB compression	P _{1dB}	Continuous wave	29.0	30		dBm
Quiescent Current	I _Q			330	380	mA
Noise Figure	NF			5.0	6.5	dB
Power added efficiency	PAE	@P _{1dB}	24	29		%

Note 1: Defined as the maximum power level for which the IEEE802.11b transmit mask requirements are met.

Note 2: Measured at the specified average output RF power and modulation type.

Note 3: Ramp-up and ramp-down times are defined from the 10% to 90% power points.

Note 4: Defined as the maximum power level for which the IEEE802.11g transmit mask requirements are met.

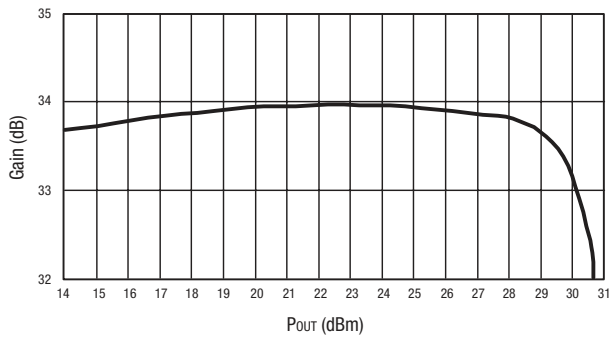

Figure 3. Typical Gain vs P_{OUT} @ 2.442 GHz

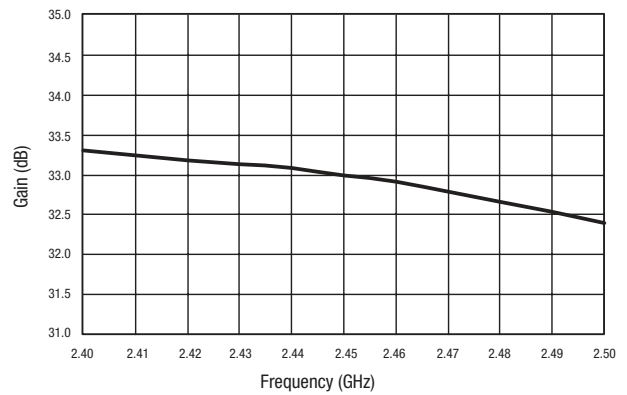

Figure 4. Typical Gain vs Frequency Response

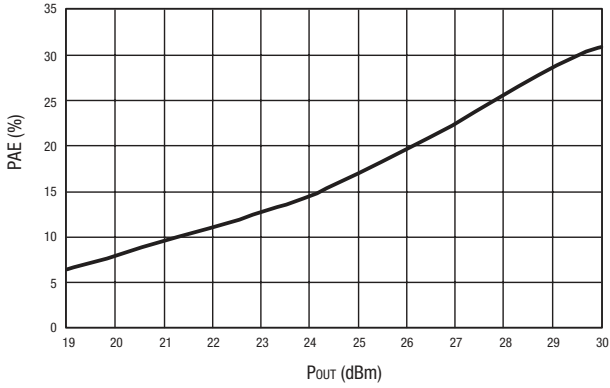

Figure 5. Power-Added Efficiency vs P_{out} @ 2.442 GHz

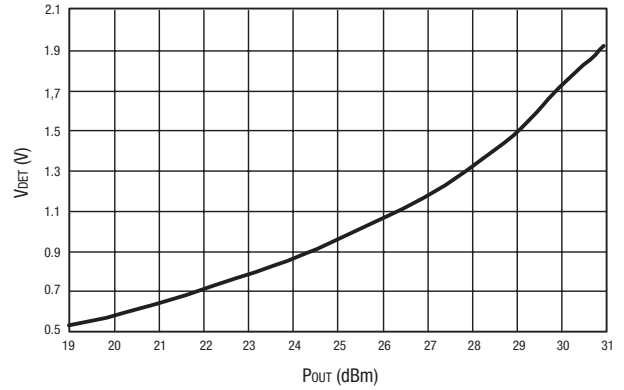

Figure 6. Detector Output Voltage vs P_{out} @ 2.442 GHz

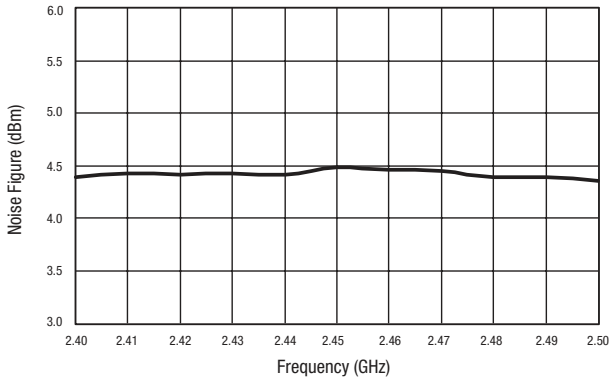

Figure 7. Typical Noise Figure Performance vs Frequency

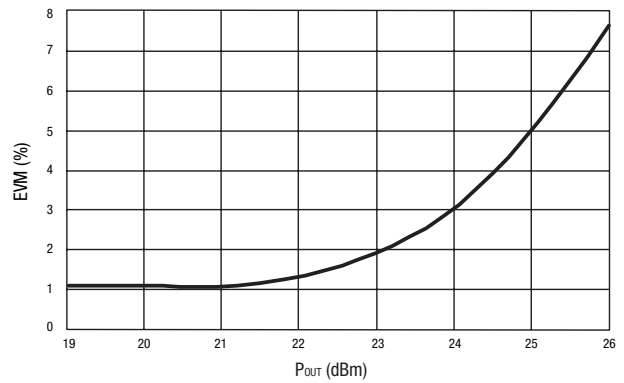

Figure 8. EVM vs P_{out} @ 2.442 GHz (802.11g, 64 Quadrature Amplitude Modulated, 54 Mbps Input Signal)

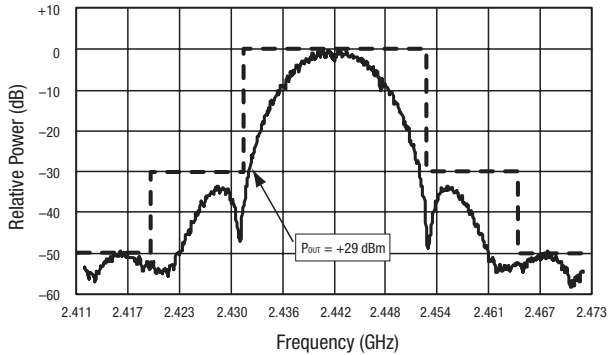

Figure 9. Output Spectrum Response for 802.11b @ 2.442 GHz (11 Mbps Input Signal)

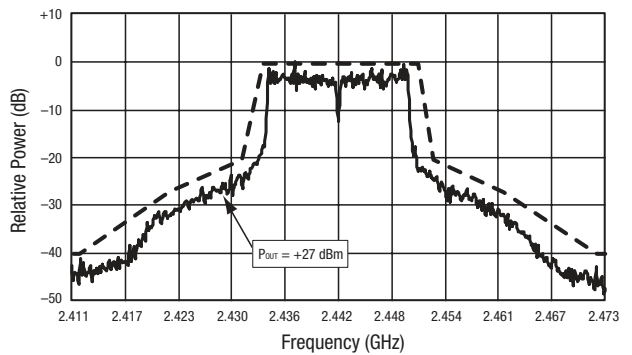
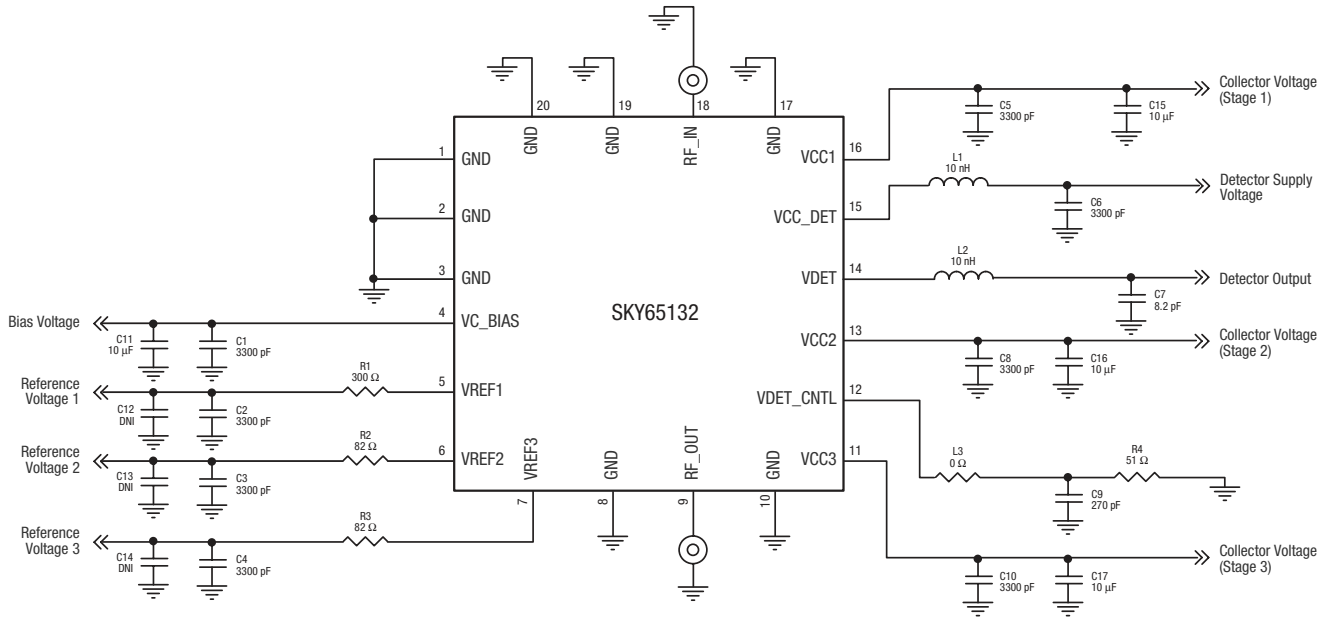

Figure 10. Output Spectrum Response for 802.11g @ 2.442 GHz (64 Quadrature Amplitude Modulated, 54 Mbps Input Signal)



Note: Evaluation Board material: four-layer Rogers 4003-12, $\epsilon_r = 3.38$

S415

Figure 10. SKY65132 Evaluation Board Schematic

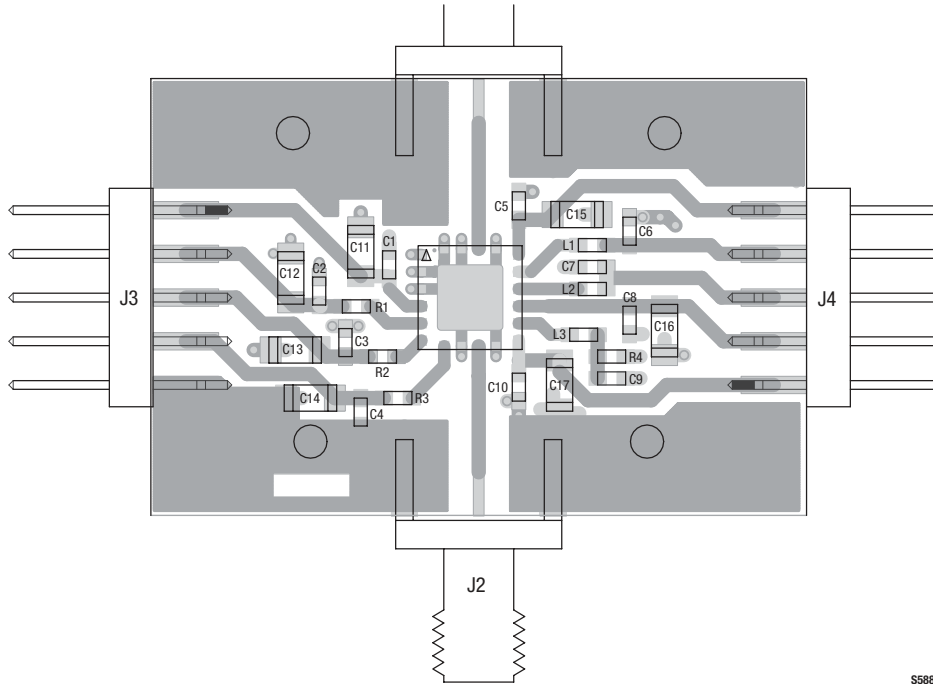

S588

Figure 11. Evaluation Board Assembly Drawing

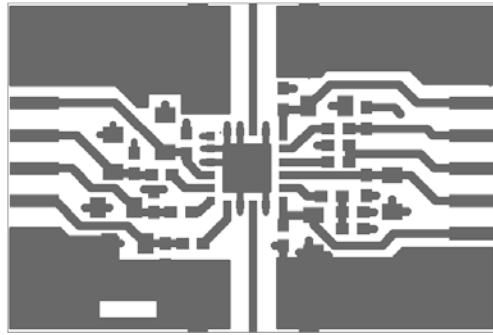

Layer 1: Top Metal

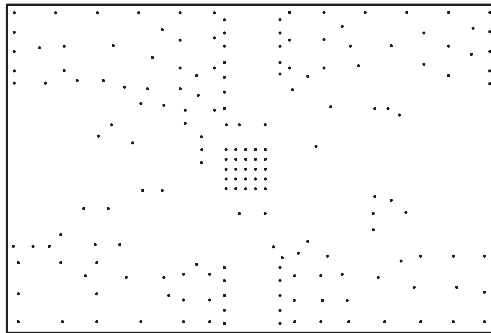

Layer 2: Ground

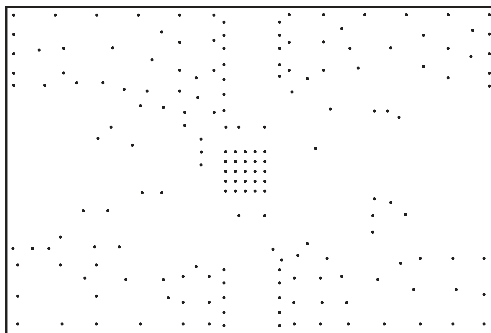

Layer 3: Inner Traces

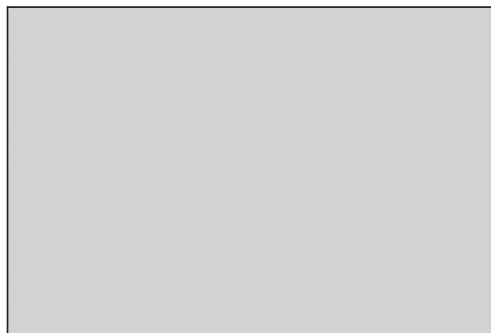

Layer 4: Ground

S590

Figure 12. Evaluation Board Layer Detail

Cross Section	Name	Thickness (mils)	Material	ϵ_r
	L1	1.4	Cu, 1 oz.	-
	Lam1	12	Rogers 4003-12	3.38
	L2_GND	1.4	Cu, 1 oz.	-
	Lam2	4	FR4-4	4.35
	L3_GND	1.4	Cu, 1 oz.	-
	Lam3	12	FR4-12	4.35
	L4	1.4	Cu, 1 oz.	-

S573

Figure 13. Layer Detail Physical Characteristics

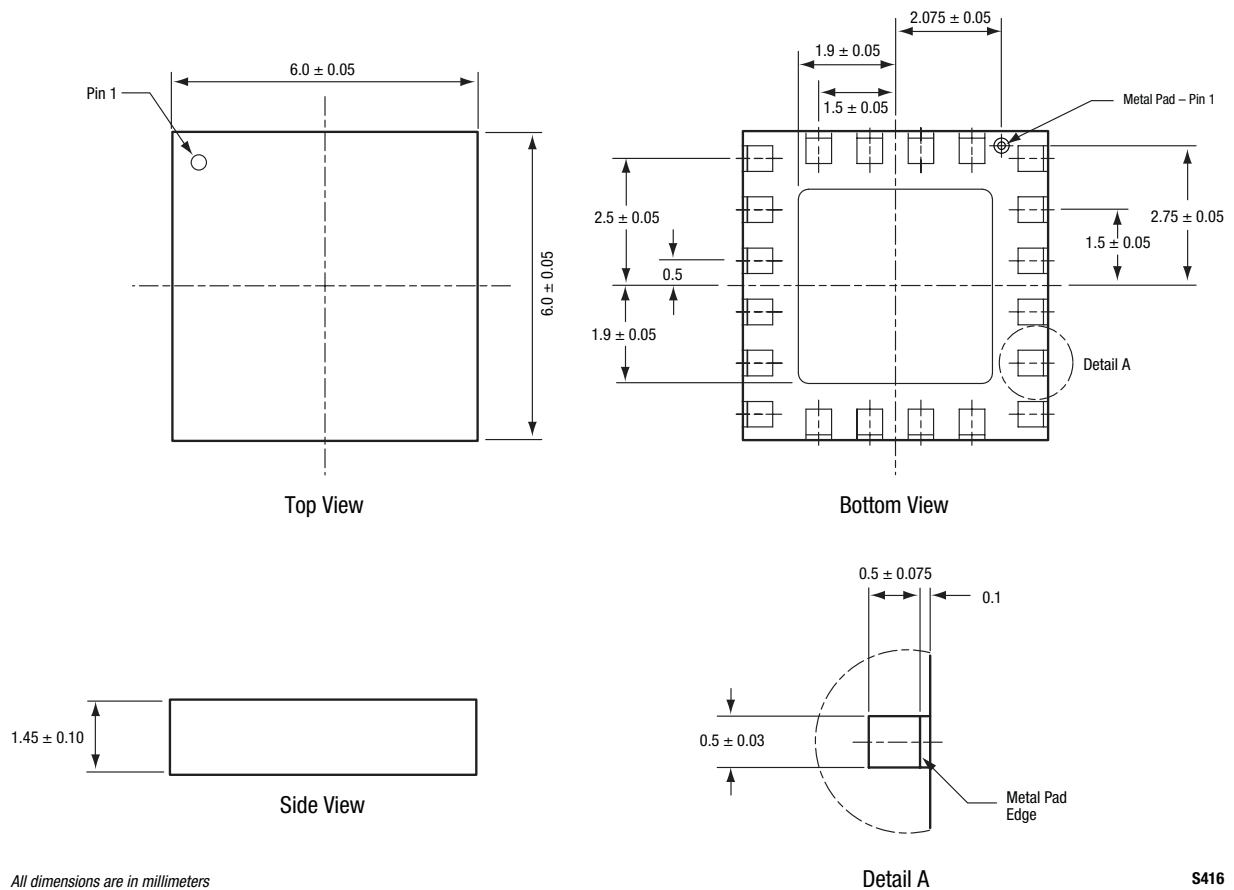

Figure 14. SKY65132 20-Pin MCM Package Dimensions

S416

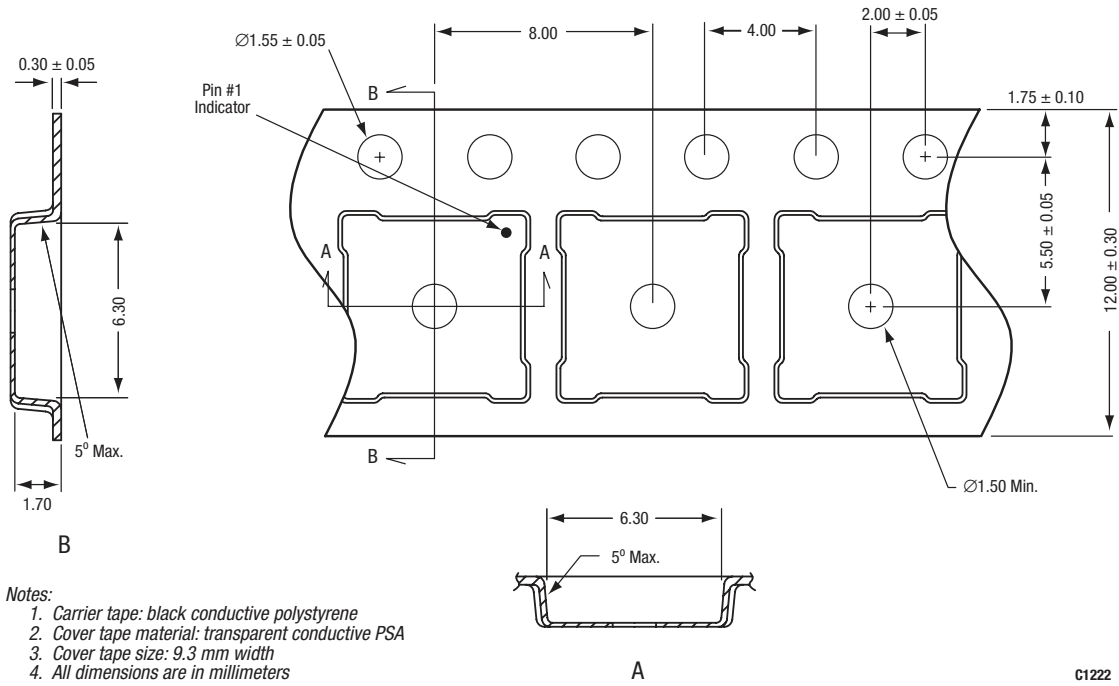

Figure 15. SKY65132 20-Pin MCM Tape and Reel Dimensions

Ordering Information

Model Name	Manufacturing Part Number	Evaluation Kit Part Number
SKY65132 WLAN Power Amplifier Module	SKY65132-21 (Pb-free package)	TW13-D121

Copyright © 2004, 2005, 2006 Skyworks Solutions, Inc. All Rights Reserved.

Information in this document is provided in connection with Skyworks Solutions, Inc. (“Skyworks”) products or services. These materials, including the information contained herein, are provided by Skyworks as a service to its customers and may be used for informational purposes only by the customer. Skyworks assumes no responsibility for errors or omissions in these materials or the information contained herein. Skyworks may change its documentation, products, services, specifications or product descriptions at any time, without notice. Skyworks makes no commitment to update the materials or information and shall have no responsibility whatsoever for conflicts, incompatibilities, or other difficulties arising from any future changes.

No license, whether express, implied, by estoppel or otherwise, is granted to any intellectual property rights by this document. Skyworks assumes no liability for any materials, products or information provided hereunder, including the sale, distribution, reproduction or use of Skyworks products, information or materials, except as may be provided in Skyworks Terms and Conditions of Sale.

THE MATERIALS, PRODUCTS AND INFORMATION ARE PROVIDED “AS IS” WITHOUT WARRANTY OF ANY KIND, WHETHER EXPRESS, IMPLIED, STATUTORY, OR OTHERWISE, INCLUDING FITNESS FOR A PARTICULAR PURPOSE OR USE, MERCHANTABILITY, PERFORMANCE, QUALITY OR NON-INFRINGEMENT OF ANY INTELLECTUAL PROPERTY RIGHT; ALL SUCH WARRANTIES ARE HEREBY EXPRESSLY DISCLAIMED. SKYWORKS DOES NOT WARRANT THE ACCURACY OR COMPLETENESS OF THE INFORMATION, TEXT, GRAPHICS OR OTHER ITEMS CONTAINED WITHIN THESE MATERIALS. SKYWORKS SHALL NOT BE LIABLE FOR ANY DAMAGES, INCLUDING BUT NOT LIMITED TO ANY SPECIAL, INDIRECT, INCIDENTAL, STATUTORY, OR CONSEQUENTIAL DAMAGES, INCLUDING WITHOUT LIMITATION, LOST REVENUES OR LOST PROFITS THAT MAY RESULT FROM THE USE OF THE MATERIALS OR INFORMATION, WHETHER OR NOT THE RECIPIENT OF MATERIALS HAS BEEN ADVISED OF THE POSSIBILITY OF SUCH DAMAGE.

Skyworks products are not intended for use in medical, lifesaving or life-sustaining applications, or other equipment in which the failure of the Skyworks products could lead to personal injury, death, physical or environmental damage. Skyworks customers using or selling Skyworks products for use in such applications do so at their own risk and agree to fully indemnify Skyworks for any damages resulting from such improper use or sale.

Customers are responsible for their products and applications using Skyworks products, which may deviate from published specifications as a result of design defects, errors, or operation of products outside of published parameters or design specifications. Customers should include design and operating safeguards to minimize these and other risks. Skyworks assumes no liability for applications assistance, customer product design, or damage to any equipment resulting from the use of Skyworks products outside of stated published specifications or parameters.

Skyworks, the Skyworks symbol, and “Breakthrough Simplicity” are trademarks or registered trademarks of Skyworks Solutions, Inc., in the United States and other countries. Third-party brands and names are for identification purposes only, and are the property of their respective owners. Additional information, including relevant terms and conditions, posted at www.skyworksinc.com, are incorporated by reference.