

TABLE 1								
STYLE	TERMINAL	"A"	"B"	"C"	"D"	"E"	"F"	"G" REF
-01	T-1S8-01-T	.175 [4.45]	.450 [11.43]	N/A	N/A	.213 [5.41]	.412 [10.46]	.462 [11.73]
-02	T-1S8-02-T	.175 [4.45]	.500 [12.70]	.100 [2.54]	.175 [4.45]	.213 [5.41]	.462 [11.73]	.512 [13.00]
-04	T-1S8-04-T	.156 [3.96]	.809 [20.55]	.195 [4.95]	.156 [3.96]	.213 [5.41]	.752 [19.10]	.802 [20.37]
-05	T-1S8-05-T	.156 [3.96]	1.069 [27.15]	.195 [4.95]	.156 [3.96]	.213 [5.41]	1.012 [25.70]	1.062 [26.97]

DO NOT SCALE FROM THIS PRINT

HFWJ-XX-XX-XX-X-XX-X

No OF POSITIONS
-01 THRU -24

OPTION
-P: PICK & PLACE PAD
(USE PPP-47, SEE FIG 2)
(-VS ONLY, 3 POSITION MIN)

LEAD STYLE
SEE TABLE 1

OPTION
-RA: RIGHT ANGLE (POST)
(N/A WITH -VS OPTION OR -01 LEAD STYLE)
-VS: VERTICAL SURFACE MOUNT
(N/A ON -01 POSITION)

PLATING SPECIFICATION
-T: TIN (USE T-1S8-XX-T)
-TM: MATTE TIN
(USE T-1S8-XX-T)

ROW SPECIFICATION
-S: SINGLE (USE HFWJ-24-156)
LEAD STYLES 01, 02, 04 & 05

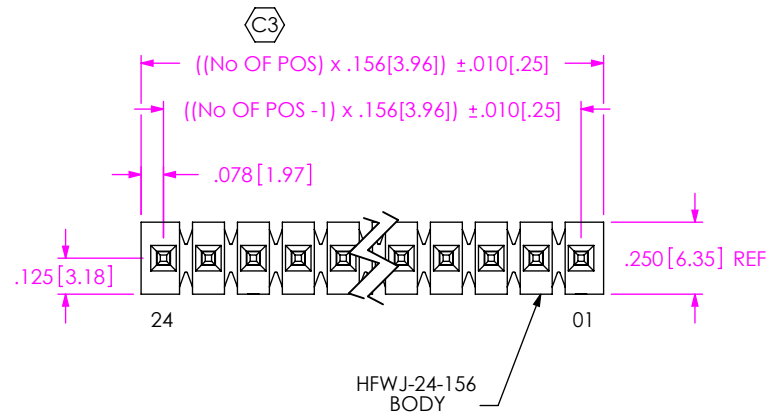

- NOTES:
1. MAX PIN ROTATION IN BODY : 2 DEGREES
 2. MINIMUM PUSHOUT FORCE : .5 LB.
 3. BURR ALLOWANCE: .0015 MAX.
 4. STANDARD & -RA PARTS TO BE BULK PACKAGED.
 5. SURFACE MOUNT (-VS) TO BE PACKAGED AS FOLLOWS:
POSITIONS -04 THRU -20 TO BE TUBE PACKAGED.
POSITIONS -02 & -03 TO BE LAYER PACKAGED.
 6. MAXIMUM CUT FLASH: .020.
 7. MAX HEIGHT VARIATION BETWEEN PINS: .005[.13]
 8. POSITIONS -02 THRU -16 TO BE .008[.20]
POSITIONS -17 THRU -24 TO BE .010[.25]
 9. C3 REPRESENTS A CRITICAL DIMENSION.
 10. -01 POSITION PARTS TO BE BULK PACKAGED.
 11. BANDOLIER AREA ON T-1S8 MUST NOT BE ENTIRELY LOCATED IN THE CONTACT AREA, POSITION ABOUT OR TOWARDS STANDOFF SIDE OF BODY.
 12. BANDOLIER AREA MUST NOT BE LOCATED IN CONTACT AREA.

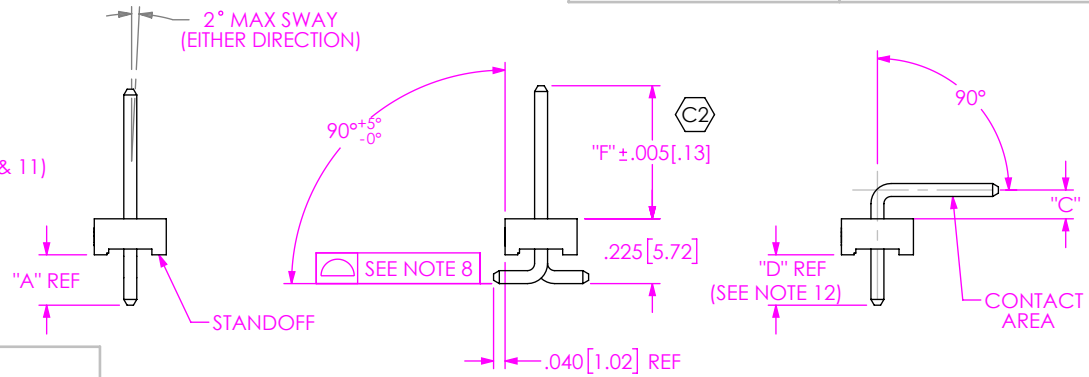
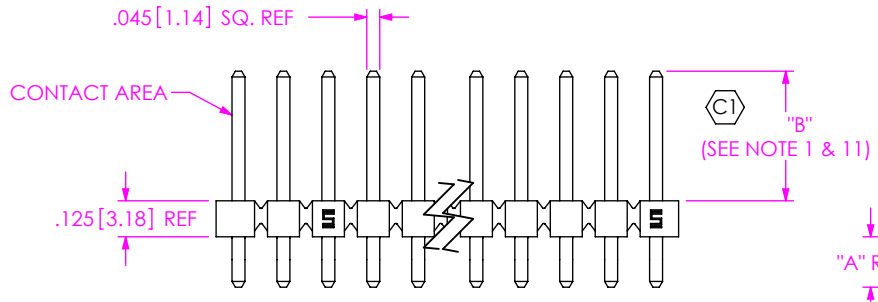
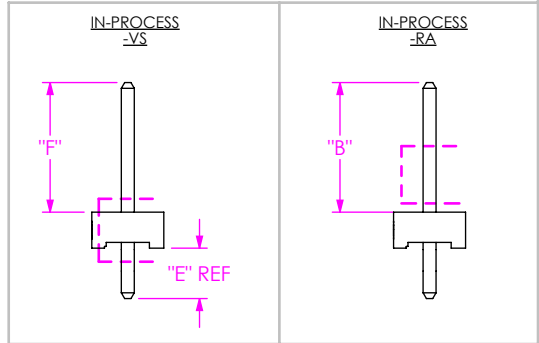

PACKAGING VIEW

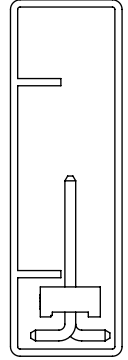

TUBE: PT-1-24-01-24
PLUG: TP-25
(SEE NOTE 5)

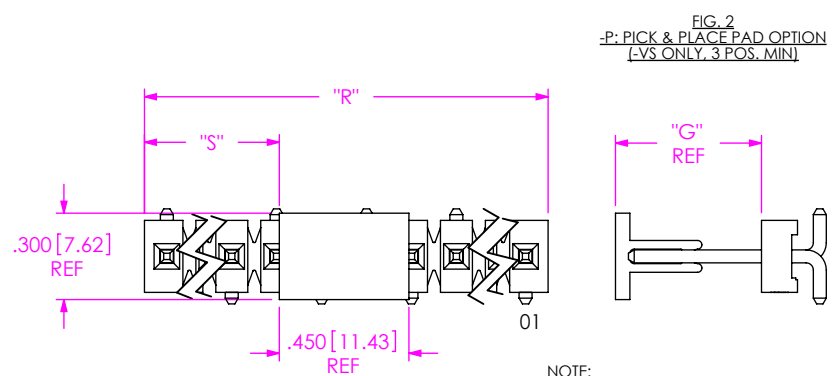

NOTE:
"R" = No OF POS x .156[3.96] REF
"S" = {("R" - .450[11.43]) / 2} ±.020[12.90]

UNLESS OTHERWISE SPECIFIED, DIMENSIONS ARE IN INCHES.
TOLERANCES ARE:
DECIMALS ANGLES
.XX: ±.01 [.3]
.XXX: ±.005 [.13]
.XXXX: ±.0020 [.051]

PROPRIETARY NOTE
THIS DOCUMENT CONTAINS CONFIDENTIAL AND PROPRIETARY INFORMATION AND ALL DESIGN, MANUFACTURING, REPRODUCTION, USE, PATENT RIGHTS AND SALES RIGHTS ARE EXPRESSLY RESERVED BY SAMTEC, INC. THIS DOCUMENT SHALL NOT BE DISCLOSED, IN WHOLE OR PART, TO ANY UNAUTHORIZED PERSON OR ENTITY NOR REPRODUCED, TRANSFERRED OR INCORPORATED IN ANY OTHER PROJECT IN ANY MANNER WITHOUT THE EXPRESS WRITTEN CONSENT OF SAMTEC, INC.

MATERIAL: DO NOT SCALE DRAWING SHEET SCALE: 1.5:1
INSULATOR: VECTRA E130; COLOR: NATURAL
CONTACT OR TERMINAL: PHOS BRONZE, 510
MAX FLASH ALLOWED: .002
MAX GATE VESTIGE: .002
F:\DWG\MISC\MKTG\HFWJ-XX-XX-XX-X-XX-X-MKT.SLDDRW



520 PARK EAST BLVD. NEW ALBANY, IN 47150
PHONE: 812-944-6733 FAX: 812-948-5047
e-Mail: info@SAMTEC.com code: 55322

DESCRIPTION:
.156[3.96] PWER BLOCK ASSEMBLY
DWG. NO. HFWJ-XX-XX-XX-X-XX-X
BY: T.WERNE 06/06/2002 SHEET 1 OF 1