

LOC		DIST		REVISIONS			
CM	00	REV	DATE	BY	CHK	APPV	
L		REVISED PER ECO-13-008064	13MAY13	DZ	YHM		

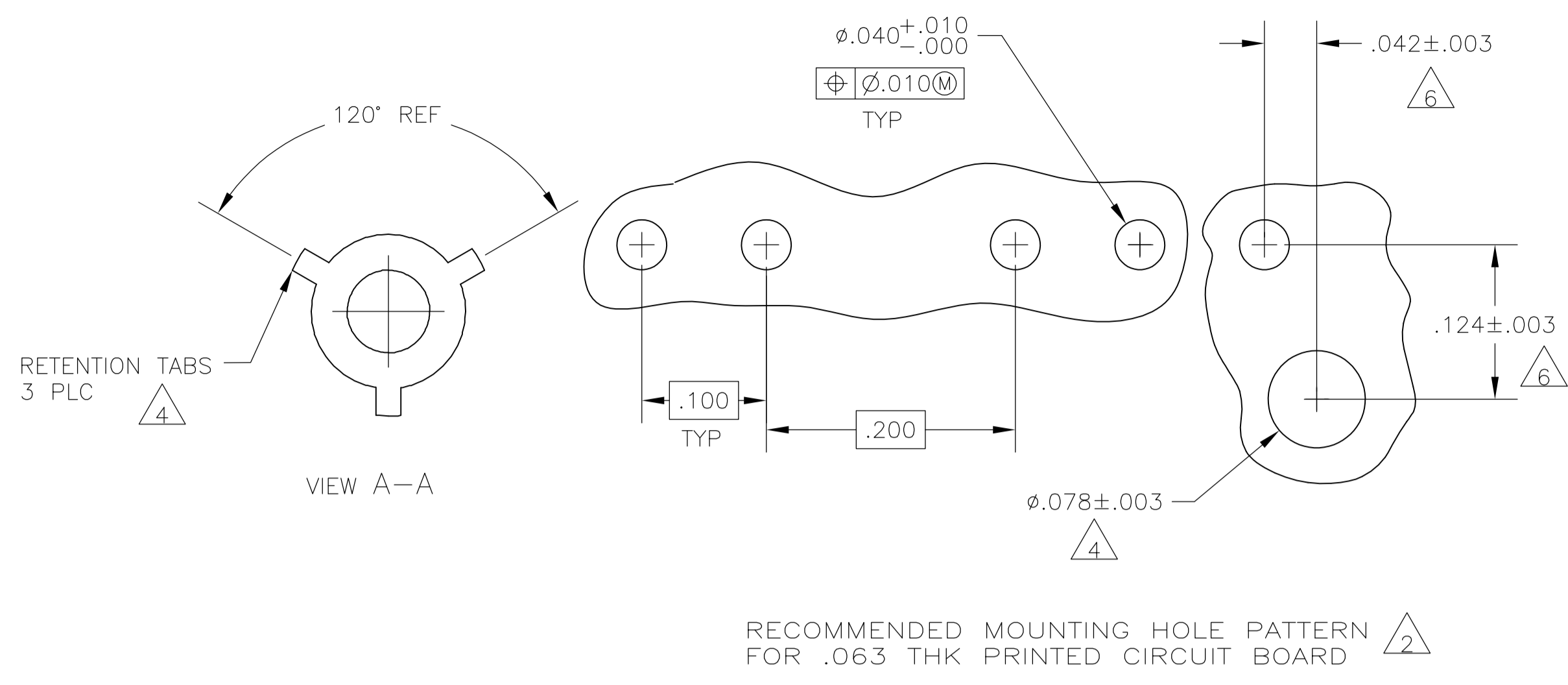

- 1 MATERIAL: HEADER- POLYESTER UL94V-0 (BLACK)  
POST- COPPER ALLOY.
- 2 SOLDER SIDE OF P.C. BOARD SHOWN.
- 3. PARTS COMPLY WITH AMP SOLDERABILITY SPEC 109-11-12.
- 4 THE RETENTION TABS PROVIDE A ONE-TIME INTERFERENCE FIT IN THE .078 DIAMETER BOARD HOLE FOR HEADER ASSEMBLY RETENTION DURING SOLDERING.
- 5 LATCH DETENT FEATURE OCCURS 2 PLACES ON EACH END (MAXIMUM OF FOUR PER PART). FOR 2 THRU 5 CIRCUIT HEADERS, LATCH FEATURE OCCURS BETWEEN EACH CIRCUIT.
- 6 COORDINATE DIMENSION APPLIES FROM CENTER OF ACTUAL FEATURE.
- 7 POST: MATTE TIN OR TIN-LEAD (93/7) PLATED. SEE TABLE TO DETERMINE PLATING TYPE.
- 8 POST NUMBER 3 OMITTED.
- 9 UL RECOGNIZED ( UR ) LOGO AND CSA LOGO WILL APPEAR ON THE SIDE OF THE PART. AMP LOGO MAY APPEAR ON SIDE OF PART OR ON BOTTOM OF PART.
- 10 TWO SIDES OF TAPER, AS SHOWN, MUST BE PLATED. TYPICAL, BOTH ENDS.
- 11 TWO SIDES OF TAPER, AS SHOWN, AND TIP MAY BE UNPLATED. TYPICAL, BOTH ENDS.
- 12 OBSOLETE PART NUMBER.

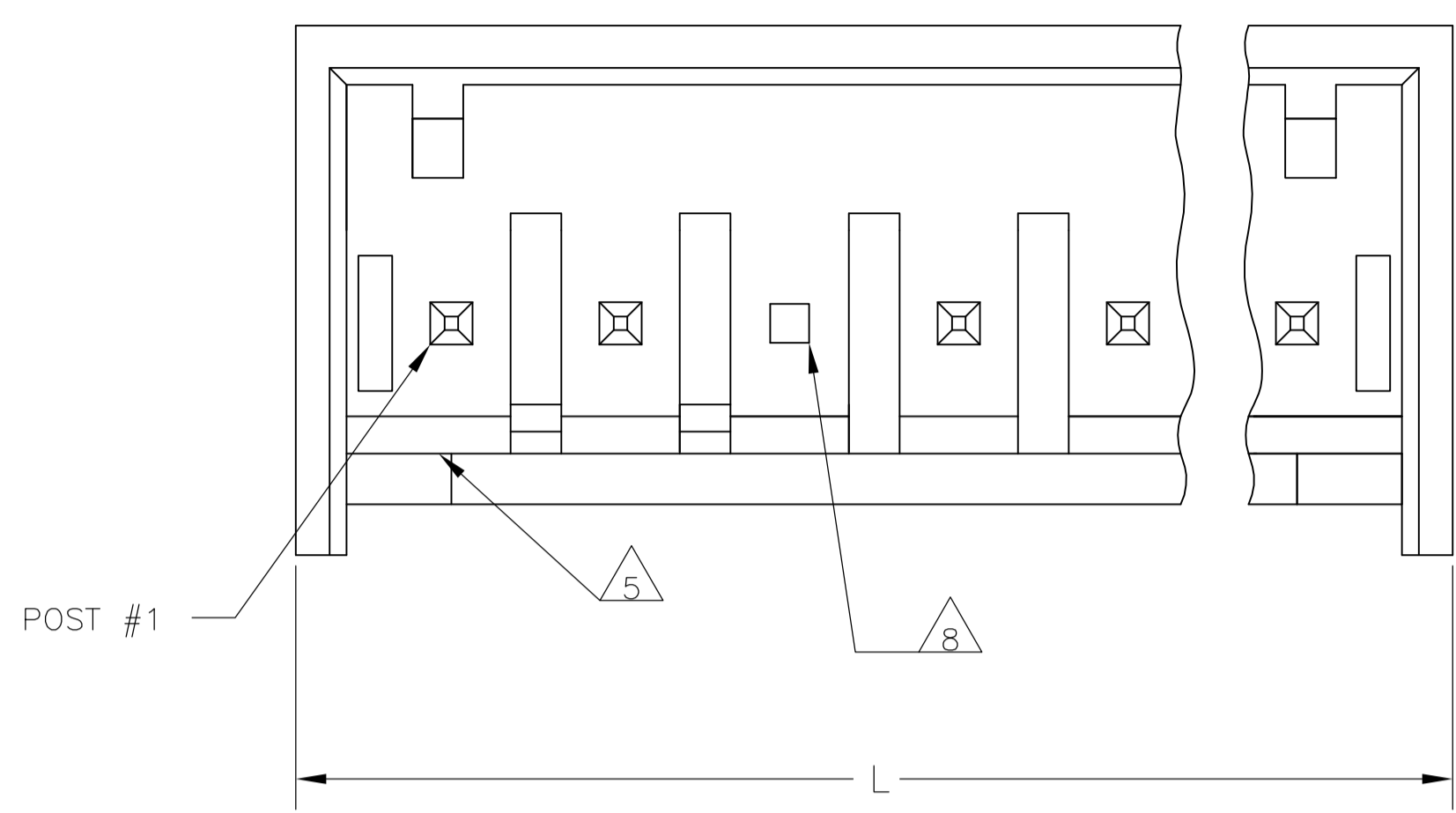
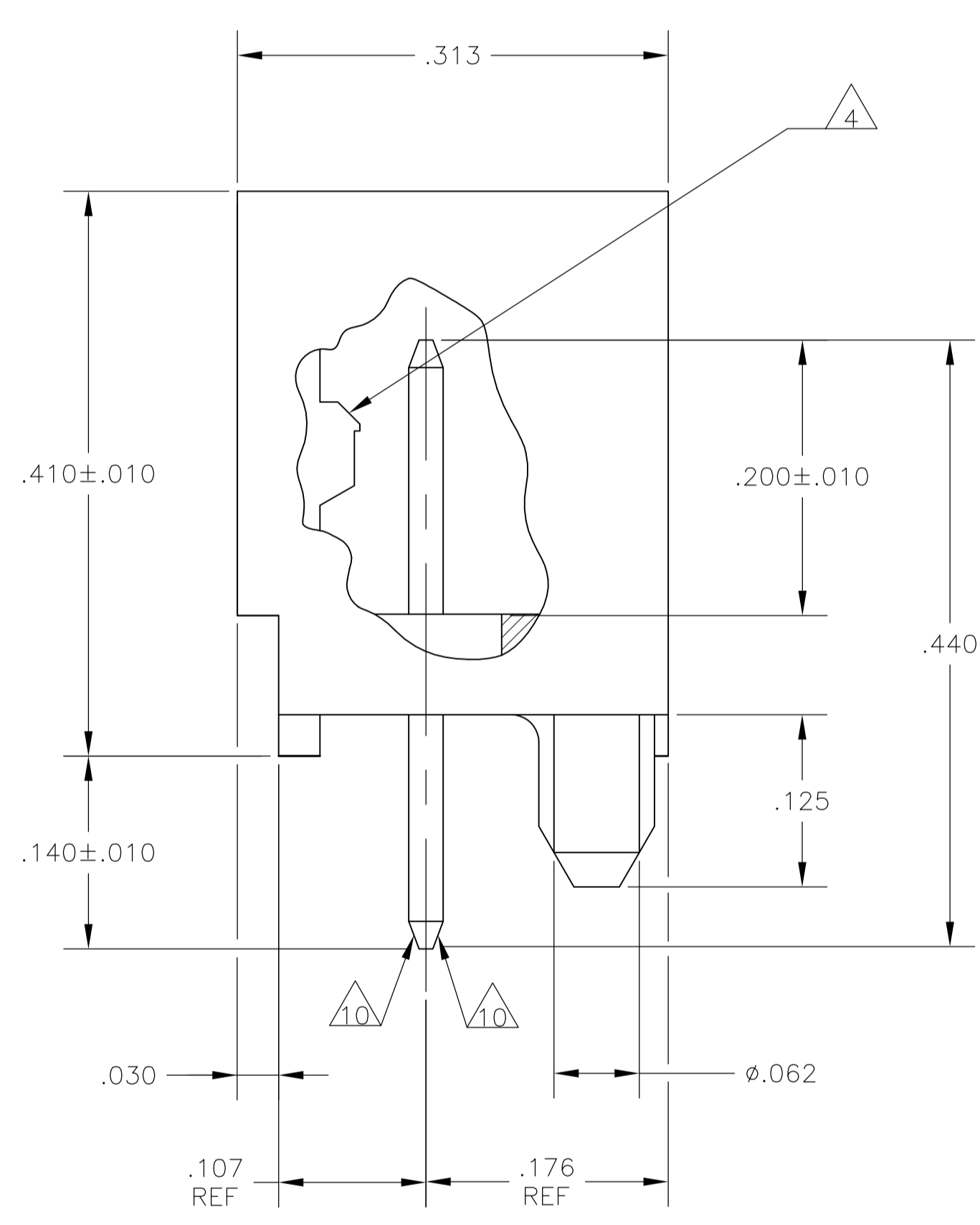
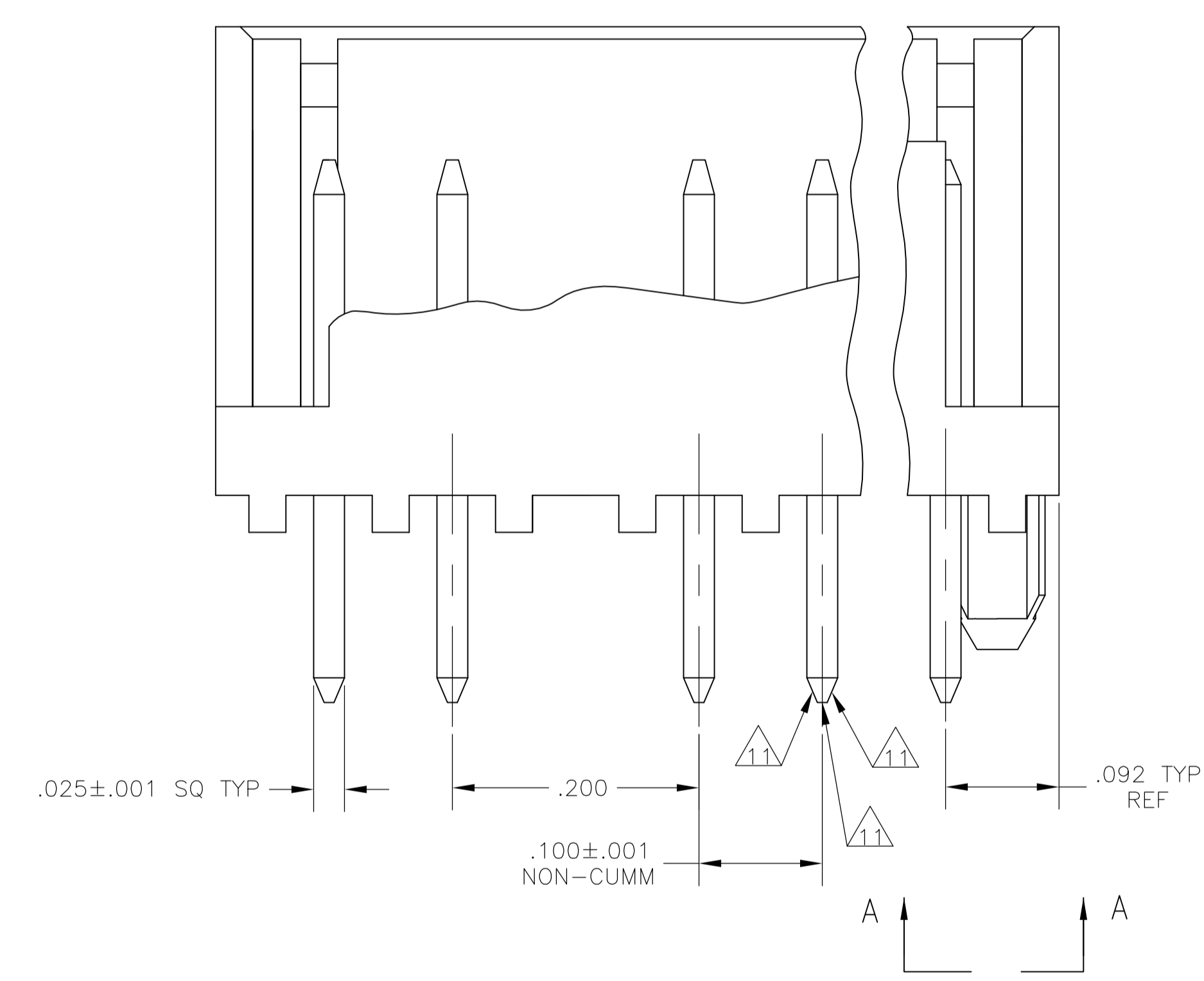

		.313	7.95	.062	1.57
		.200	5.08	.042	1.07
		.176	4.47	.040	1.02
		.140	3.56	.030	0.76
		.125	3.18	.025	0.64
		.124	3.15	.010	0.25
		.107	2.72	.005	0.13
		.100	2.54	.003	0.08
		.092	2.34	.001	0.03
.440	11.18	.078	1.98	.000350	0.009
.410	10.41	.063	1.60	.000150	0.004
INCH	MM	INCH	MM	INCH	MM

CONVERSION TABLE

12 SUPERSEDED  
12 SUPERSEDED

3-644729-6 SHOWN

FINISH	IN	MM	NO OF POSITIONS	PART NUMBER
MATTE TIN	.684	17.37	6	3-644729-6
	.484	12.04	4	3-644729-4
TIN-LEAD	.684	17.37	6	644729-6
	.484	12.04	4	644729-4
L		HEADER ASSEMBLY		

THIS DRAWING IS A CONTROLLED DOCUMENT.

APPROVED: **D. ROSSI** 31 AUG 04  
 CHECKED: **D. ROSSI** 31 AUG 04  
 DRAWN: **K. WHITAKER** 31 AUG 04

TE Connectivity

NAME: MTA-100 SHROUDED HEADER ASSEMBLY, FRICTION LOCK, STRAIGHT POST, TIN OR TIN OR TIN LEAD PLATED, POST NO. 3 OMITTED

APPLICATION SPEC: ---  
 SIZE: A1  
 CASE CODE: ---  
 DRAWING NO: 00779  
 WEIGHT: ---  
 CUSTOMER DRAWING: ---

SCALE: 10:1 SHEET 1 OF 1 REV L

