

Ratings

Voltage: 150 V
 Temperature: -40~70 °C

Conductor

Conductor count: 8
 Gauge: 28 AWG 0.08 mm²
 Material: Tinned copper strands
 Strand size: $\varnothing 0.05 \times 40$
 Resistance at 20 °C: 240 Ω /km Max

Insulator

Material: HDPE
 Color: red, black, white, yellow, blue, green, orange, purple
 Diameter: $\varnothing 0.7 \pm 0.10$ mm
 Nominal thickness: 0.16 mm
 Resistance at 20 °C: 100 M Ω /km Min

Wrap

Material: cotton paper

Filler

Material: aramid fiber

Outer jacket

Material: TPU
 Color: white
 Diameter: $\varnothing 3.5 \pm 0.20$ mm
 Nominal thickness: 0.5 mm

Tests

Tensile strength: 26 kgf min
 Dielectric test: 1500 V dc for 1 minute without breakdown
 Bend test at 200 g, $\pm 60^\circ$, 30 cycles /min: 15,000 cycle minimum

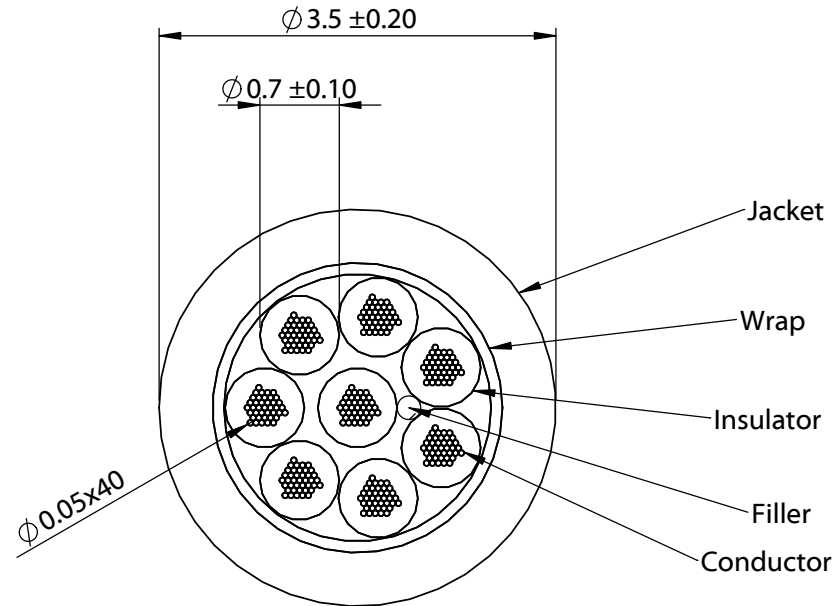
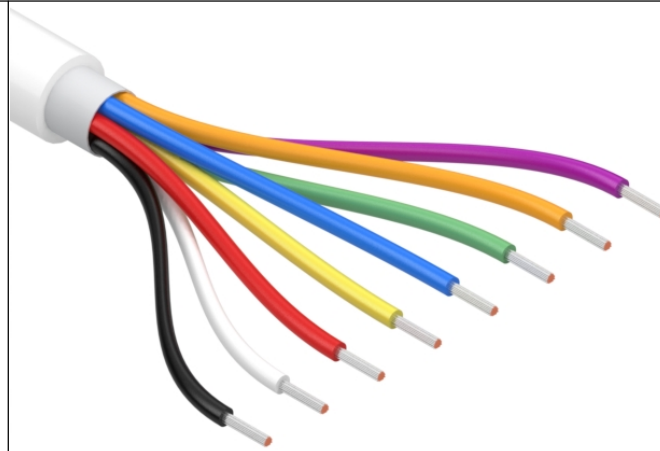

Revision:	Date:	Description:
A	9/12/2022	Initial release

Prepared: **MP**
Digitally signed by MP
 Date: 2022.09.23 13:32:33 -0700

Verified: **PB**
Digitally signed by PB
 Date: 2022.09.23 14:20:43 -0700

Dimensions are in millimeters.
 Tolerances:
 X: ± 0.5 mm
 X.X: ± 0.3 mm
 X.XX: ± 0.05 mm

Notes:
 RoHS compliant
 Jacket meets ISO 10993 Biological Compatibility
 Phthalate and halogen free
 Function test: no open, no short, no intermittent

Description:
 Wire, 8C TS, 28 AWG, 150V, 70C, 3.5 mm, TPU, 75A, white, WBL

TENSILITY

tel 1.541.323.3228 800 877.670.7118
 fax 1.541.323.4202 web tensility.com

Size: A Part number: 30-02827

Scale: 15:1 Sheet 1 of 1