

**FEATURES**

- Self-powered from 85 to 264Vac / 45-65Hz supplies
- 0.01Hz resolution & quartz crystal accuracy and stability
- Installs in "oiltight" 1.20 inch (30.5mm) round cutouts
- Four-digit LED display with out-of-range indication
- Digital replacement for analog panel meters
- Self-resetting internal fuse for long-term reliability
- Supplied with EPDM rubber gasket and plastic hex nut
- Provides moisture ingress protection to IP67/NEMA 6
- Screw-style input terminal block simplifies installation
- Knockout punches and tooling available
- Approvals to UL/cUL/IEC/ 61010-1

MPS Part Number	Product Status
DMR20-1-KP	Discontinued
DMR20-2-KP	Discontinued
DMR20-3-KP	Discontinued

**NOTE: See the table on the back page for recommended substitutes.**



**cULus** E156931

**Performance/Functional Specifications**

Typical at Ta = +25°C, Vin = 250Vac / 60Hz sine wave, unless otherwise noted

**AC Input (TB1)**

Voltage Range ☒ 85 to 264Vac (45-65 Hz)  
 Current Consumption 250Vac/60Hz: 12mA (max.)  
 UL/IEC61010-1 Measurement Category II

**Performance**

Sampling Rate 2-3 readings/second  
 Resolution 0.01Hz  
 Accuracy @ +25°C ±0.01Hz (typ.), ±0.02Hz (max.)  
 Temperature Drift ±0.0005Hz/°C (-25 to +60°C)

**Mechanical**

Dimensions 1.5" diameter x 1.1" depth (38 x 28mm)  
 Display Type Four digit, LED, 0.30" high (7.6mm)  
 Weight 0.9 ounces (25.5 grams)  
 Case Material Polycarbonate  
 Terminal Block Torque 2.2 lb-in (0.25 N·m) ±20%  
 Wire Size And Type 18-22AWG (0.83-0.33mm<sup>2</sup>) copper, solid or stranded  
 Wire Insulation Strip Length 0.25" (6.4mm)

**Environmental**

Operating Temperature -25 to +60°C  
 Storage Temperature -40 to +75°C  
 Humidity (non-condensing) 0 to 85%

☒ Operation and accuracy with ac inputs above or below this range are not specified. Operation from waveforms other than sine waves is limited to 120Vrms. See Technical Note 1 for additional information.

Murata Power Solutions' new DMR20-1-FM is the world's smallest, self-powered, ac line frequency monitor. Simply connect 85 to 264Vac (45-65Hz) power and the meter is fully operational—no additional components are required. The unit can also measure distorted 120Vrms power sources with triangle and square waveforms, as well as quasi sine wave outputs of dc to ac power inverters.

An ultra-stable, quartz-crystal controlled microprocessor provides accuracies of ±0.02Hz over the operating temperature range of -25 to +60°C. DMR20-1-FM frequency monitors feature a large, 0.30"/7.6mm, bright LED display that can be easily read from 10 feet away (3 meters). A built-in resettable fuse and out-of-range indication assures long term reliability.

The DMR20-1-FM is housed in a rugged, round polycarbonate case that provides excellent protection against moisture, dust, shock and vibration. Panel installation is straightforward: using available tooling, simply drill and punch a 1.2 inch (30.5mm) diameter hole and anti-rotation notch, insert the meter and gasket, and securely fasten the meter using the supplied hex nut. The nut and gasket are designed to provide moisture ingress protection to IP67/NEMA 6.

DMR20-1-FM is exactly the same size as Murata Power Solutions' DMR20-1-ACV (ac volts), DMR20-10-DCM (dc volts), and DMR20-1-TMP (temperature) digital panel meters.

**Ordering Information**

**DMR20-1-FM-R-C** 85 to 264Vac frequency monitor (Red LED)

**Knockout Punches**

- DMR20-1-KP** 1.2" (30.5mm) Round knockout punch (no keying notch)
- DMR20-2-KP** 1.2" (30.5mm) Round knockout punch (with four keying notches)
- DMR20-3-KP** 1/8" and 3/16" (3.2 and 4.7mm) key-notch nibbler tool

Note: An M30 x 1.5 nylon hex nut and EPDM sealing gasket are supplied with each meter. The "-C" suffix denotes RoHS compliance.



**TECHNICAL NOTES**



**IMPORTANT! To ensure safe and reliable operation, DMR20-1-FM ac frequency monitors must be installed and serviced by qualified technical personnel. Contact Murata Power Solutions if there is any doubt regarding their installation or operation.**

- 1. Measurement Type:** DMR20-1-FM meters are designed to be powered from sine wave ac supplies, over their rated input of 85-264Vac (45-65Hz). Operation from triangle, square, and quasi-sine waveforms is limited to a maximum of 85 to 120rms (45-65Hz).
- 2. Calibration:** DMR20-1-FM frequency monitors are factory calibrated; there are no provisions for calibrating these meters in the field.
- 3. Operating Range:** As the sine wave ac input voltage is lowered below 100Vac (50 or 60Hz), the DMR20-1-FM's display may begin to dim slightly, but the readings will remain accurate down to 85Vac. Input frequencies below 45Hz and above 65Hz will display as four dashes, indicating an out-of-range input condition.
- 4. Panel Installation:** All electrical connections to DMR20-1-FM must be made after the meter is securely attached to the panel, and with the input ac supply de-energized (off). In high-vibration environments, adequate strain reliefs must be used on all supply wiring. See Figure 1 for typical panel mounting details.

**Tightening Torque:**

The recommended tightening torque for the M30 x 1.5 plastic hex nut is 10 to 17 in-lbs (1.3 to 1.9 N-m). If a torque wrench is not available, this recommended range can be approximated by hand tightening the hex nut SLOWLY until it just bottoms out against the panel's rear surface. From this bottomed-out reference position, using a suitable tool, tightening the hex nut ¼ turn clockwise will produce approximately 10 in-lbs (1.3 N-m) of torque; tightening it 3/8 turn clockwise will produce approximately 17 in-lbs (1.9 N-m).

Check to make sure the housing's anti-rotation key is aligned with the notches on both the panel and the gasket before tightening the hex nut. Over tightening the hex nut will distort the rubber gasket and may damage the threads on both the nut and the housing, thereby compromising the installation's mechanical integrity and its ability to protect against environmental effects.

**Panel Thickness:**

When using both the factory supplied EPDM gasket and hex nut (the recommended standard installation method), the DMR20-1-FM can be mounted in panels ranging from 0.032" to 0.250" (0.8 to 6.4mm) thick. When the gasket is not used, the panel thickness range is 0.075" to 0.325" (1.9 to 8.3mm). However, using the factory supplied hardware and tightening torque recommendations provides optimal resistance to vibration, dust, and moisture ingress.

**Panel Materials:**

Acceptable panel materials include aluminum, mild steels, plastics, FR-4 pc-board (fiberglass), and many other materials with a flat matte surface on both

sides of the cutout. The DMR-20-x-KP tools can be used with most panel materials except stainless steel or other hardened metals.

DMR20-1-FM has passed vibration testing combined with temperature cycling while mounted to the materials noted above, using the specified tightening torques. If the meter will be mounted to extremely smooth, slippery surfaces, the user is advised to test the completed assembly under the environmental conditions encountered in the end application.

- 5. AC Input Fusing and Wiring:** DMR20-1-FM frequency monitors contain an internal, self-resettable fuse. However, the supply wires connected to input terminals TB1-A and TB1-B must be fused with an external, user supplied, 0.25A/300V time delay/time lag fuse, in accordance with applicable regulatory codes.

All supply wiring must be rated for the voltages and currents they will conduct and comply with any code or application-mandated requirements pertaining to the user's specific installation. 300V, UL-rated hook-up wire suitable for the intended application is required. TB1 is to be used only for powering the meter's internal circuitry; it must not be used to supply power to external loads.

The recommended TB1 supply wire size is 18AWG to 22AWG (0.83mm<sup>2</sup> to 0.33mm<sup>2</sup>) solid or stranded copper wire. The supply wires must be properly stripped and attached to TB1 such that their insulation is not pinched by the screw terminal. Recommended insulation strip length is 0.25" (6.4mm). When using stranded wire, verify that there are no loose or stray strands that could potentially cause a short circuit across the ac supply input.

- 6. AC Input Polarity and Grounding:** The ac supply inputs TB1-A and TB1-B terminals are not polarity sensitive, that is, neither terminal is designated as "AC LO" or "AC HI." DMR20-1-FM frequency monitors do not include, nor require, a connection to earth/chassis ground.

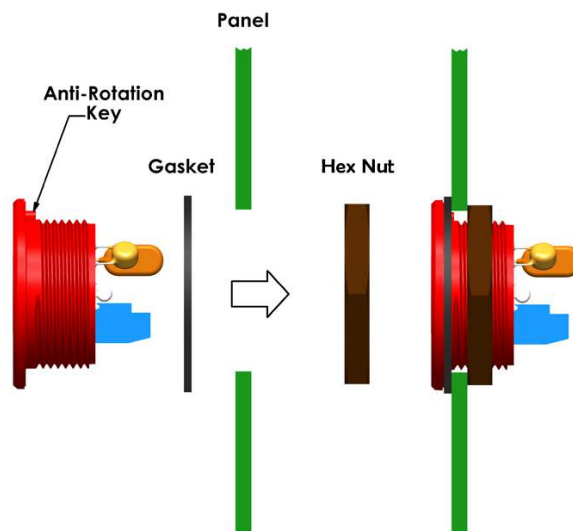
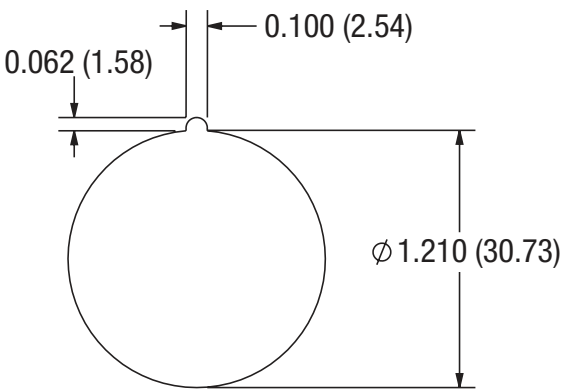
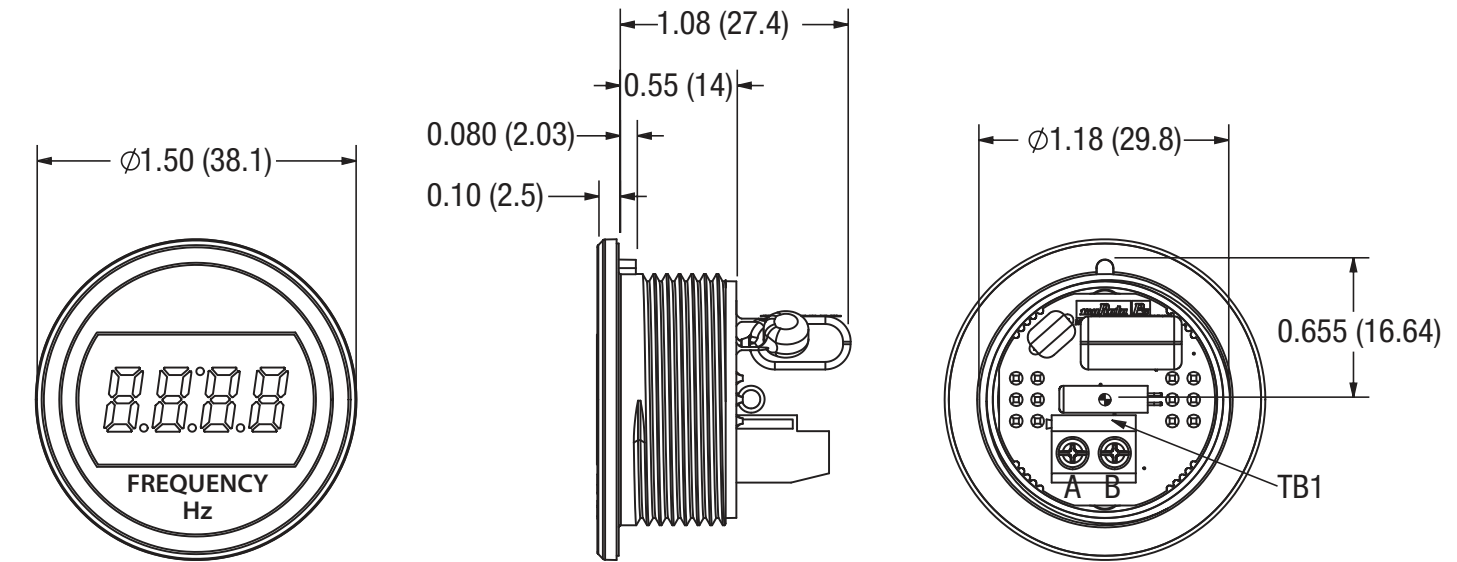

Figure 1. Panel Installation

**MECHANICAL SPECIFICATIONS**



Recommended panel cutout

Dimensions are in inches (mm).

Tolerances (unless otherwise specified):

.XX ± 0.02 (0.51)

.XXX ± 0.010 (0.254)

Angles ± 2°

Components are shown for reference only.

**3D models are available at [www.murata-ps.com/en/3d/meters.html](http://www.murata-ps.com/en/3d/meters.html)**

**1. Description of safety marks:**

- Caution, risk of electrical shock
- Caution, risk of danger
- Equipment is partially protected by double or reinforced insulation

**2. Cleaning Instructions: Gently clean with dry cloth only.**

**3. Caution: if the equipment is used in a manner not specified by Murata Power Solutions, the protection provided by the equipment may be impaired.**

Murata Power Solutions, Inc.  
11 Cabot Boulevard, Mansfield, MA 02048-1151 U.S.A.  
ISO 9001 and 14001 REGISTERED



**This product is subject to the following operating requirements and the Life and Safety Critical Application Sales Policy: Refer to: <http://www.murata-ps.com/requirements/>**

Murata Power Solutions, Inc. makes no representation that the use of its products in the circuits described herein, or the use of other technical information contained herein, will not infringe upon existing or future patent rights. The descriptions contained herein do not imply the granting of licenses to make, use, or sell equipment constructed in accordance therewith. Specifications are subject to change without notice.  
© 2023 Murata Power Solutions, Inc.



# DMR20-1-FM

Self-Powered,  
LED Display, AC Line Frequency Monitor

MPS Part Number	Description	Recommended Replacement Part	
		Manufacturer	Part Number
DMR20-1-KP	Round knockout punch (no keying notch)	Greenlee	36508
DMR20-2-KP	Round knockout punch (4 keying notches)	N/A	
DMR20-3-KP	Key notch nibbler toll	Greenlee	720

Murata Power Solutions, Inc.  
11 Cabot Boulevard, Mansfield, MA 02048-1151 U.S.A.  
ISO 9001 and 14001 REGISTERED



**This product is subject to the following operating requirements and the Life and Safety Critical Application Sales Policy:**  
Refer to: <http://www.murata-ps.com/requirements/>

Murata Power Solutions, Inc. makes no representation that the use of its products in the circuits described herein, or the use of other technical information contained herein, will not infringe upon existing or future patent rights. The descriptions contained herein do not imply the granting of licenses to make, use, or sell equipment constructed in accordance therewith. Specifications are subject to change without notice.  
© 2023 Murata Power Solutions, Inc.