

---

**3-Wire Serial Interface Real Time Clock IC with Battery Backup Switch-over Function**

---

NO.EA-226-160701

**OUTLINE**

The R2262x is a CMOS real-time clock IC connected to the CPU by three signal lines, CE, SCLK, SIO, and configured to perform serial transmission of time and calendar data to the CPU. Further, battery backup switchover circuit and a voltage detector are incorporated for secondary battery. The periodic interrupt circuit is configured to generate interrupt signals with six selectable interrupts ranging from 0.5 seconds to 1 month. The 2 alarm interrupt circuits generate interrupt signals at preset times. As the oscillation circuit is driven under constant voltage, fluctuation of the oscillator frequency due to supply voltage is small, and the time keeping current is small (Typ. 0.30 $\mu$ A at 3V). The oscillation halt sensing circuit can be used to judge the validity of internal data in such events as power-on; the supply voltage monitoring circuit is configured to record a drop in supply voltage below supply voltage monitoring threshold setting. The 32.768 kHz clock output function (CMOS output) is intended to output sub-clock pulses for the external microcomputer. The oscillation adjustment circuit is intended to adjust time counts with high precision by correcting deviations in the oscillation frequency of the crystal oscillator. Battery backup switchover function is the automatic switchover circuit between a main power supply and a backup battery of secondary battery. Since the package for this IC is TSSOP10G (R2262T) or QFN0202-18 (R2262L), high density mounting of ICs on boards is possible.

**FEATURES**

- Minimum Timekeeping supply voltage Typ.0.6 to 5.5V (Worst: 0.9 V to 5.5 V); BAT pin
- Ultra low power consumption Typ.0.30  $\mu$ A at  $V_{BAT} = 3V$  (Max. 0.90  $\mu$ A)
- Built-in Backup switchover circuit (can be used for a secondary battery, or an electric double-layer capacitor)
- Three signal lines (CE, SCLK, and SIO) required for connection to the CPU.  
(Maximum clock frequency of 1MHz (with VCC = 3V))
- Time counters (counting hours, minutes, and seconds) and calendar counters (counting years, months, days, and weeks) (in BCD format)
- Interrupt circuit configured to generate interrupt signals (with interrupts ranging from 0.5 seconds to 1 month) to the CPU and provided with an interrupt flag and an interrupt halt
- 2 alarm interrupt circuits (Alarm\_W for week, hour, and minute alarm settings and Alarm\_D for hour and minute alarm settings)
- Built-in voltage detector with delay
- With Power-on flag to prove that the power supply starts from 0V
- 32-kHz clock output pin (CMOS push-pull output. "H" level is always equal to VCC.)
- Supply voltage monitoring circuit with supply voltage monitoring threshold setting
- Automatic identification of leap years up to the year 2099
- Selectable 12-hour and 24-hour mode settings
- High precision oscillation adjustment circuit
- Built-in oscillation stabilization capacitors (CG and CD)
- Package TSSOP10G (4.0 x 2.9 x 1.0: R2262T), QFN0202-18 (2.0 x 2.0 x 0.43: R2262L)
- CMOS process

---

## R2262x

---

NO.EA-226-160701

### SELECTION GUIDE

In the R2262x, users can select the IC with designating the package, function version according to the application. Part Number is designated as follows:

R2262L01-E2 ←Part Number

↑↑↑

R2262a-bb-cc

Code	Description
a	Designation of the package. L: QFN0202-18 T: TSSOP10G
bb	Serial number of Voltage detector setting etc.
cc	Designation of the taping type. Only E2 is available.

Part Number	Package	-V <sub>DET1</sub> (Typ.)	-V <sub>RGOUT</sub> (Typ.)	Quality per Reel	Pb Free
R2262L01-E2	QFN0202-18	2.7 V	3.0 V	3,000 pcs	Yes
R2262T01-E2-F	TSSOP10G	2.7 V	3.0 V	2,000 pcs	Yes

## BLOCK DIAGRAM

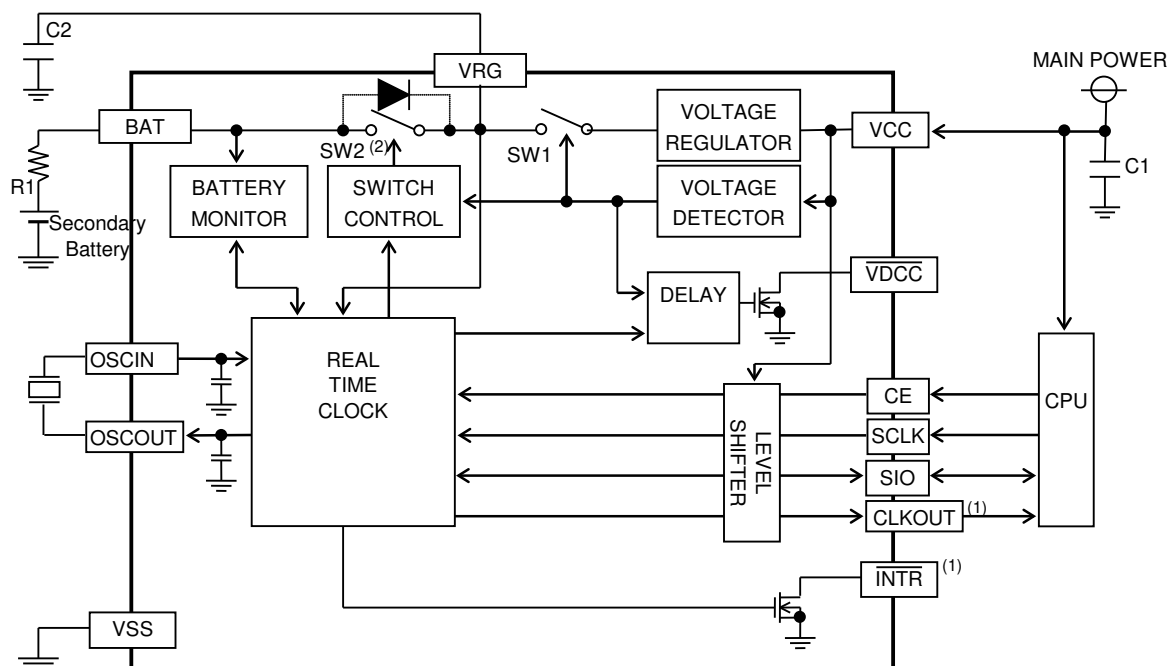

(1) CLKOUT and  $\overline{\text{INTR}}$  pins are non-connecting (NC) pin in the R2262T only.

(2) SW2 becomes OFF when VCC exceeds VDET1 and the SW2C bit is "1". This switch can use to stop charging and discharging for a secondary battery at test.

## R2262x

NO.EA-226-160701

## PIN CONFIGURATION

R2262L (QFN0202-18)

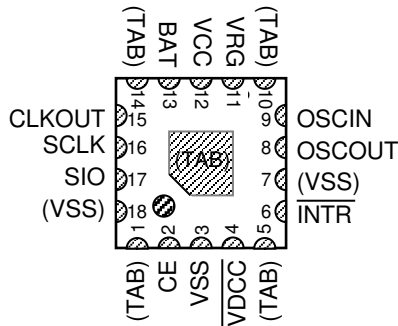

TOP VIEW

R2262Txx (TSSOP10G)

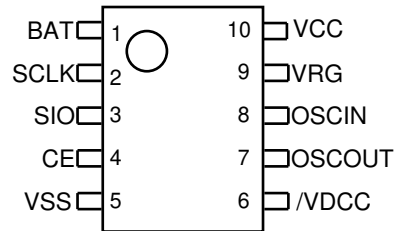

TOP VIEW

## PIN DESCRIPTION

Pin No.		Symbol	Item	Description
R2262L (QFN)	R2262T (TSSOP)			
2	4	CE	Chip Enable Input	The CE pin is used for interfacing with the CPU. Should be held high to allow access to the CPU. Incorporates a pull-down resistor. Should be held low or open when the CPU is powered off. Allows a maximum input voltage of 5.5 volts regardless of supply voltage.
16	2	SCLK	Serial Clock Input	The SCLK pin is used to input clock pulses synchronizing the input and output of data to and from the SIO pin. Allows a maximum input voltage of 5.5 volts regardless of supply voltage.
17	3	SIO	Serial Input / Output	The SIO pin is used to input or output data intended for writing or reading in synchronization with the SCLK pin.
6	-	$\overline{\text{INTR}}$	Interrupt Output	The $\overline{\text{INTR}}$ pin is used to output alarm interrupt (Alarm_W) and alarm interrupt (Alarm_D) and output periodic interrupt signals to the CPU signals. Disabled at power-on from 0V. Nch. open drain output.
15	-	CLKOUT	32kHz Clock Output	The CLKOUT pin is used to output 32.768-kHz clock pulses. CMOS output. "H" level is always equal to VCC.
12	10	VCC	Main Battery Input	Supply power to the IC.
11	9	VRG	Internal Power Output	Internal power output. Connect a capacitor as much as 0.1 $\mu\text{F}$ between VRG and VSS.

Pin No.		Symbol	Item	Description
R2262L (QFN)	R2262T (TSSOP)			
13	1	BAT	Power Supply Input for Secondary Backup Battery	Connect a secondary battery for backup. If VCC level is equal or less than $-V_{DET1}$ , power is supplied from this pin.
4	6	$\overline{VDCC}$	VCC Power Supply Monitoring Result Output	While monitoring VCC Power supply, if the voltage is equal or lower than $-V_{DET1}$ , this output level is "L". When $\overline{VDCC}$ becomes "L", SW1 turns off. When VCC is equal to $+V_{DET1}$ or more, SW1 turns on. After t DELAY passed, $\overline{VDCC}$ output becomes off, or "H". Nch Open-drain output.
9	8	OSCIN	Oscillation Circuit Input	The OSCIN and OSCOUT pins are used to connect the 32.768-kHz quartz crystal unit (with all other oscillation circuit components built into the R2262x).
8	7	OSCOUT	Oscillation Circuit Output	
3	5	VSS	Negative Power Sup Supply Input	The VSS pin is grounded.
7,18	-	(VSS)		Connect to ground line, or do not connect any lines.
1,5, 10,14	-	(TAB)		Tab is GND level. The tab is better to be connected to the GND.

## R2262x

NO.EA-226-160701

### ABSOLUTE MAXIMUM RATINGS

(V<sub>SS</sub>=0V)

Symbol	Item	Pin Name	Description	Unit
V <sub>CC</sub>	Supply Voltage 1	VCC	-0.3 to +6.5	V
V <sub>BAT</sub>	Supply Voltage 2	BAT	-0.3 to +6.5	V
V <sub>I</sub>	Input Voltage 1	CE, SCLK	-0.3 to +6.5	V
	Input Voltage 2	SIO	-0.3 to V <sub>CC</sub> +0.3	V
V <sub>O</sub>	Output Voltage 1	$\overline{\text{INTR}}^{(1)}$ , $\overline{\text{VDCC}}$	-0.3 to +6.5	V
	Output Voltage 2	SIO, CLKOUT <sup>(1)</sup> , VRG	-0.3 to V <sub>CC</sub> +0.3	V
I <sub>OUT</sub>	Maximum Output Current	VRG	10	mA
P <sub>D</sub>	Power Dissipation	T <sub>a</sub> = 25°C	300	mW
T <sub>a</sub>	Operating Temperature		-40 to +85	°C
T <sub>stg</sub>	Storage Temperature		-55 to +125	°C

### RECOMMENDED OPERATING CONDITIONS

(V<sub>SS</sub> = 0V, -40°C ≤ T<sub>a</sub> ≤ 85°C)

Symbol	Item	Conditions	Min.	Typ.	Max.	Unit
V <sub>ACCESS</sub>	Supply Voltage	VCC power supply voltage for interfacing with CPU	-V <sub>DET1</sub> <sup>(2)</sup>		5.5	V
V <sub>CLK</sub>	Time keeping Voltage	CGout, CDout = 0pF <sup>(3) (4)</sup>	0.9		5.50	V
V <sub>CLKL</sub>	Minimum Time keeping Voltage	CGout, CDout = 0pF <sup>(3) (4)</sup>		0.6	0.9	
V <sub>xstp</sub>	Oscillation halt sensing Voltage	Power supply which satisfies the condition XSTP=1 <sup>(5)</sup> CGout = CDout = 0pF <sup>(3) (4)</sup>		0.6	0.9	V
f <sub>XT</sub>	Oscillation Frequency			32.768		kHz
V <sub>PUP</sub>	Pull-up Voltage	$\overline{\text{INTR}}^{(1)}$ , $\overline{\text{VDCC}}$			5.5	V

(1) Except R2262Tx

(2) -V<sub>DET1</sub> in V<sub>ACCESS</sub> specification is guaranteed by design.

(3) CGout is connected between OSCIN and VSS, CDout is connected between OSCOUT and VSS. R2262x incorporates the capacitors between OSCIN and VSS, between OSCOUT and VSS. Then normally, CGout and CDout are not necessary.

(4) Quartz crystal unit: CL (load capacity) = 6pF to 8pF, R1 (equivalent series resistance) = under 75kΩ to 80kΩ (Max.).

(5) XSTP is the crystal oscillation halt sensing flag. When the crystal oscillation halts, XSTP=1.

## DC ELECTRICAL CHARACTERISTICS

Unless otherwise specified:  $V_{SS}=0V$ ,  $V_{CC}=3.0V$ ,  $-40^{\circ}C \leq T_a \leq 85^{\circ}C$ , Crystal oscillator= 32.768kHz

### R2262T01, R2262L01

Symbol	Item	Pin Name	Conditions	Min.	Typ.	Max.	Unit
$V_{IH1}$	"H" Input Voltage 1	CE, SCLK		$0.8 \times V_{CC}$		5.5	V
$V_{IH2}$	"H" Input Voltage 2	SIO		$0.8 \times V_{CC}$		$V_{CC}+0.3$	
$V_{IL}$	"L" Input Voltage	CE, SIO SCLK		-0.3		$0.2 \times V_{CC}$	
$I_{OH}$	"H" Output Current	SIO, CLKOUT <sup>(1)</sup>	$V_{OH}=V_{CC}-0.5V$			-0.5	mA
$I_{OL1}$	"L" Output Current 1	SIO, CLKOUT <sup>(1)</sup>	$V_{OL}=0.4V$	0.5			mA
$I_{OL2}$	"L" Output Current 2	$\overline{INTR}$ <sup>(1)</sup>		2.0			
$I_{OL3}$	"L" Output Current 3	$\overline{VDCC}$		$V_{BAT}, V_{CC}=2.0V$ $V_{OL}=0.4V$	0.5		
$I_{IL}$	Input Leakage Current	SCLK	$V_I=5.5V$ or $V_{SS}$	-0.2		0.2	$\mu A$
$R_{DNCE}$	Pull-down Input Register	CE		40	120	400	k $\Omega$
$I_{OZ1}$	Output Off-state Current 1	SIO	$V_O=5.5V$ or $V_{SS}$	-0.2		0.2	$\mu A$
$I_{OZ2}$	Output Off-state Current 2	$\overline{INTR}$ <sup>(1)</sup> , $\overline{VDCC}$	$V_O=5.5V$ or $V_{SS}$	-0.2		0.2	$\mu A$
$I_{BAT}$	Time Keeping Current at Backup mode	BAT	$V_{CC}=0V, V_{BAT}=3.0V,$ Output=OPEN Time Keeping <sup>(2)</sup>		0.3	0.9	$\mu A$
$V_{DETB}$	Supply Voltage Monitoring Voltage	BAT	$V_{CC}=0V,$ $T_a=25^{\circ}C$	1.20	1.35	1.50	V
$-V_{DET1}$	Detector Threshold Voltage (Falling edge of VCC)	VCC	$T_a=25^{\circ}C$	2.63	2.70	2.78	V
$+V_{DET1}$	Detector Released Voltage (Rising edge of VCC)	VCC	$T_a=25^{\circ}C$	2.69	2.78	2.87	V
$\frac{\Delta V_{DET}}{\Delta T_a}$	Detector Threshold / Released Voltage Temperature Coefficient	VCC, BAT	$-40^{\circ}C \leq T_a \leq 85^{\circ}C$ <sup>(3)</sup>		$\pm 100$		ppm/ $^{\circ}C$
$V_{RGOUT}$	VRG Output Voltage	VRG	$T_a=25^{\circ}C, V_{CC}=3.3V,$ $I_{OUT}=1.0mA$	2.92	3.00	3.08	V
$\frac{\Delta V_{RGOUT}}{\Delta T_a}$	VRGOUT Temperature Coefficient	VRG	$-40^{\circ}C \leq T_a \leq 85^{\circ}C$ <sup>(3)</sup>		$\pm 100$		ppm/ $^{\circ}C$
$V_{BATOUT1}$	BAT Output Voltage 1	BAT	$T_a=25^{\circ}C,$ $V_{CC}=3.0V,$ $I_{OUT}=1.0mA$	$V_{CC}$ -0.10	$V_{CC}$ -0.03		V
CG	Internal Oscillation Capacitance 1	OSCIN			10		pF
CD	Internal Oscillation Capacitance 2	OSCOUT			10		

<sup>(1)</sup> Except R2262Txx

<sup>(2)</sup> R1 of Crystal=30k $\Omega$ . CGout=CDout=0pF

<sup>(3)</sup> Guaranteed by design.

## AC ELECTRICAL CHARACTERISTICS

Unless otherwise specified,  $V_{SS}=0V$ ,  $-40^{\circ}C \leq T_a \leq 85^{\circ}C$

Input and Output Conditions:  $V_{IH}=0.8 \times V_{CC}$ ,  $V_{IL}=0.2 \times V_{CC}$ ,  $V_{OH}=0.8 \times V_{CC}$ ,  $V_{OL}=0.2 \times V_{CC}$ ,  $C_L=50pF$

Symbol	Item	Conditions	$V_{CC} \geq 1.7V$ <sup>1</sup>			Unit
			Min.	Typ.	Max.	
$t_{CES}$	CE Set-up Time		400			ns
$t_{CEH}$	CE Hold Time		400			ns
$t_{CR}$	CE Recovery Time		62			$\mu s$
$f_{SCLK}$	SCLK Clock Frequency				1.0	MHz
$t_{CKH}$	SCLK Clock "H" Time		400			ns
$t_{CKL}$	SCLK Clock "L" Time		400			ns
$t_{CKS}$	SCLK Set-up Time		200			ns
$t_{RD}$	Data Output Delay Time				300	ns
$t_{RZ}$	Data Output Floating Time				300	ns
$t_{CEZ}$	Data Output Delay Time after Falling of CE				300	ns
$t_{DS}$	Input Data Set-up Time		200			ns
$t_{DH}$	Input Data Hold Time		200			ns
$t_{DELAY}$	Output Delay Time of Voltage Detector	Time Keeping	100	105	110	ms

For reading/writing timing, see "Considerations in Reading and Writing Time Data under special condition in Interfacing with the CPU".

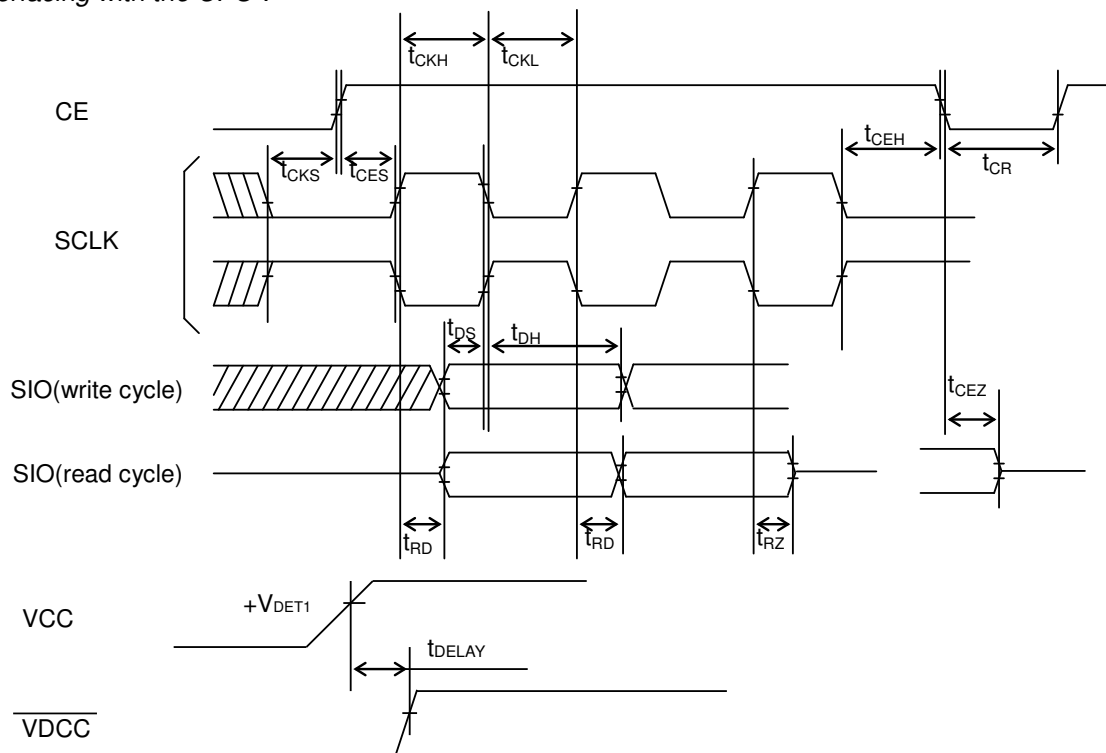

<sup>(1)</sup> VCC voltage interfacing with CPU is defined by  $V_{ACCESS}$  in "RECOMMENDED OPERATING CONDITIONS".



## PACKAGE DIMENSIONS

### R2262L (QFN0202-18)

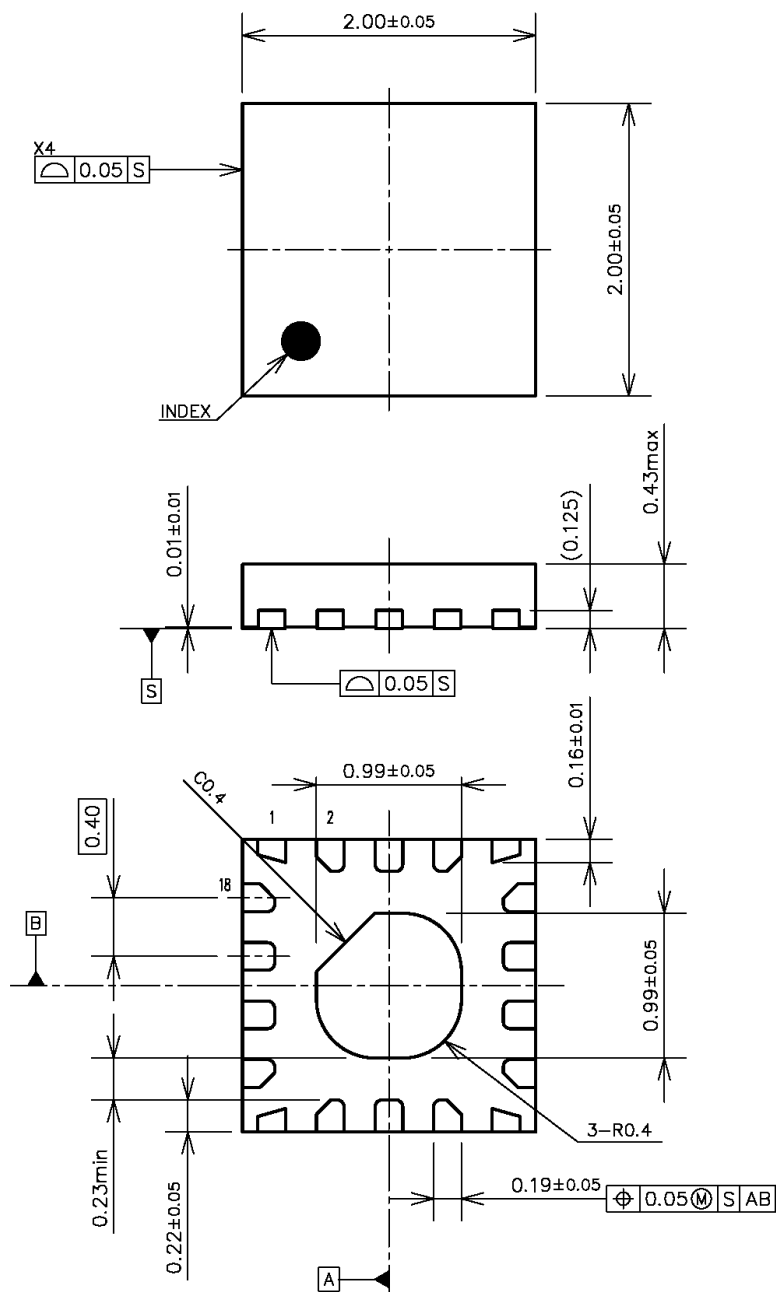

Unit: mm

Tab is VSS level. (They are connected to the reverse side of this IC.) The tab is better to be connected to the VSS. The side of the all terminals have no plating treatment. Therefore, it may not be able to form solder fillet on the side of the terminals.

---

**R2262x**

---

NO.EA-226-160701

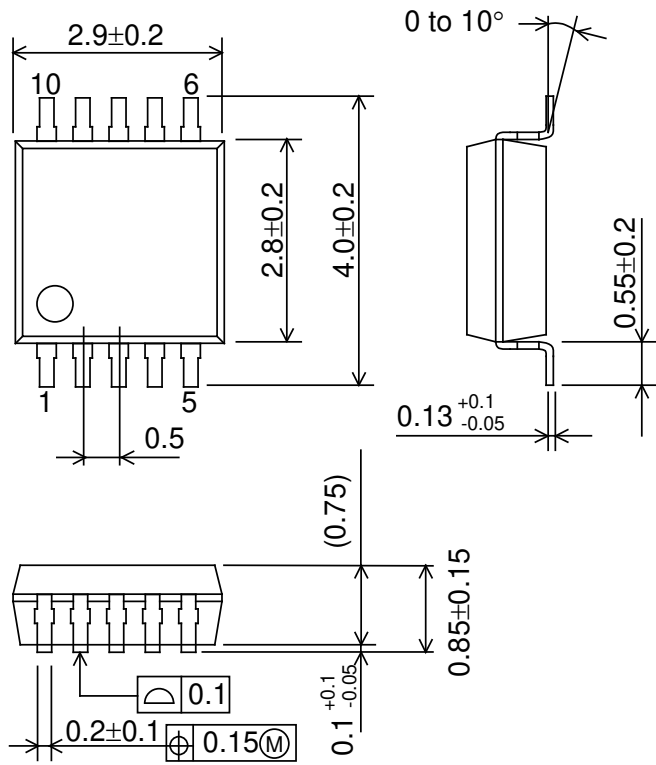
**R2262T (TSSOP10G)**

Unit: mm

## GENERAL DESCRIPTION

### Battery Backup Switchover Function

The R2262x have three power supply input, or VCC, BAT and VRG. With monitoring VCC pin input voltage, which voltage between the two is supplied to the internal power supply is decided.

Refer to the next table to see the state of the backup battery and internal power supply's state of the IC by each condition.

$V_{CC} \geq V_{DET1}$	$V_{CC} < V_{DET1}$
VCC→RTC, VRG, BAT VDCC =OFF (H)	BAT→RTC, VRG VDCC = L

As a backup battery, not only a secondary battery such as ML614 or TC616, but also an electric double layered capacitor or an aluminum capacitor can be used. The R2262x integrates a voltage regulator between VCC and VRG for constant voltage charging the secondary battery. Most of secondary batteries and electric double layered capacitors specify the maximum charging voltage, and the internal voltage regulator of the R2262x can satisfy the specifications easily. The R2262x integrates a switch between VRG and BAT. The charging and discharging of the secondary battery can be halted by the resistor control from the R2262x. In case of that VRG starts up from 0V, the initial setting of the resistor makes turning on the switch. The relation among SW2, power sources (VCC and BAT), and SW2C is shown in the next table. If the user needs to turn off SW2 such that a current consumption is measured at test, this bit must be set. However, default setting must be "0".

VCC	BAT	SW2C	SW1	SW2	Comment
OPEN (0.0V)	0.0V →3.0V	indefinite →0	Indefinite →off	Indefinite →on	After supplying BAT power, (PON=1), SW2C=0(SW2=on) is set, when $V_{CC} < -V_{DET1}$ becomes true, SW1=off is realized.
0.0V →3.3V	0.0V	indefinite →0	indefinite →on	indefinite →on	After supplying VCC power, (PON=1), SW2C=0(SW2=on) is set, when $V_{CC} > -V_{DET1}$ becomes true, SW1=on is realized and charging the secondary battery starts.
3.3V →0.0V	3.0V	0	on →off	on	With attachment of BAT power, when $V_{CC} < -V_{DET1}$ is true, SW1=off is realized, and discharging from the secondary battery starts.
0.0V →3.3V	3.0V	0	off →on	on	With attachment of BAT power, when $V_{CC} > +V_{DET1}$ is true, SW1=on is realized and status is changed from discharging the secondary battery into charging the secondary battery.
3.3V →0.0V	3.0V	1	on →off	off →on	When SW2C=1 is set, and with attachment of BAT power, when $V_{CC} < -V_{DET1}$ is true, SW1=off is realized, at the same time, SW2 turns on, and discharging from the secondary battery starts.
0.0V →3.3V	3.0V	1	off →on	on →off	When SW2C=1 is set, and with BAT power, when $V_{CC} > +V_{DET1}$ is true, SW1=on is realized, at the same time, SW2 turns off. At this moment, the connection between the secondary battery and VCC is cut off, therefore, the current measurement of VCC without charging current of secondary battery is possible.

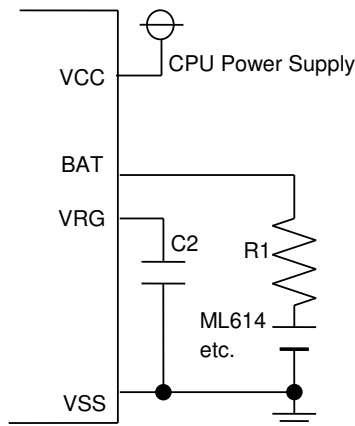

In the case of back up by capacitor or secondary battery  
(Charging voltage is equal to CPU power supply voltage)

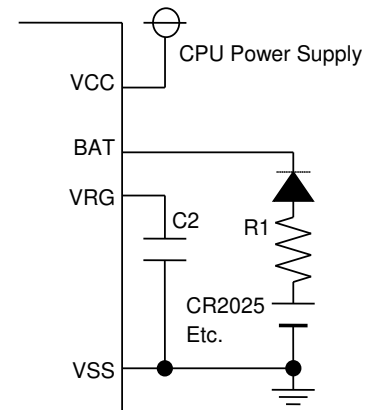

In the case of back up by primary battery

### Interface with CPU

The R2262x is connected to the CPU by three signal lines CE (Chip Enable), SCLK (Serial Clock), and SIO (Serial Input / Output), through which it reads and writes data from and to the CPU. The CPU can be accessed when the CE pin is held high. Access clock pulses have a maximum frequency of 1 MHz, allowing high-speed data transfer to the CPU. VCC falls down under  $-V_{DET1}$ , the R2262x stops accessing with CPU.

### Clock and Calendar Function

The R2262x reads and writes time data from and to the CPU in units ranging from seconds to the last two digits of the calendar year. The calendar year will automatically be identified as a leap year when its last two digits are a multiple of 4. Consequently, leap years up to the year 2099 can automatically be identified as such.

### Alarm Function

The R2262x incorporates the alarm interrupt circuit configured to generate interrupt signals to the CPU at preset times. The alarm interrupt circuit allows two types of alarm settings specified by the Alarm\_W registers and the Alarm\_D registers. The Alarm\_W registers allow week, hour, and minute alarm settings including combinations of multiple day-of-week settings such as "Monday, Wednesday, and Friday" and "Saturday and Sunday". The Alarm\_D registers allow hour and minute alarm settings. The Alarms outputs from  $\overline{\text{INTR}}$  pin. Each alarm function can be checked from the CPU by using a polling function. R2262Tx has Alarm\_D and Alarm\_W registers, but does not have  $\overline{\text{INTR}}$  output pin.

### High-precision Oscillation Adjustment Function

The R2262x has built-in oscillation stabilization capacitors (CG and CD), which can be connected to an external crystal oscillator to configure an oscillation circuit. Two kinds of accuracy for this function are alternatives. To correct deviations in the oscillator frequency of the crystal, the oscillation adjustment circuit is configured to allow correction of a time count gain or loss (up to  $\pm 1.5\text{ppm}$  or  $\pm 0.5\text{ppm}$  at  $T_a=25^\circ\text{C}$ ) from the CPU. The maximum range is approximately  $\pm 189\text{ppm}$  (or  $\pm 63\text{ppm}$ ) in increments of approximately 3ppm (or 1ppm).

Such oscillation frequency adjustment in each system has the following advantages:

- \* Allows timekeeping with much higher precision than conventional RTCs while using a crystal oscillator with a wide range of precision variations.
- \* Corrects seasonal frequency deviations through seasonal oscillation adjustment.
- \* Allows timekeeping with higher precision particularly with a temperature sensing function out of RTC, through oscillation adjustment in tune with temperature fluctuations.

### **Power-on Reset, Oscillation Halt Sensing Function and Supply Voltage Monitoring Function**

The R2262x has 2 power supply pins (VCC, BAT), among them,  $\overline{\text{VCC}}$  pin and BAT pin have monitoring function of supply voltage. VCC power supply monitoring circuit makes  $\overline{\text{VCC}}$  pin “L” when VCC power supply pin becomes equal or lower than  $-V_{\text{DET}}$ . At the power-on of VCC, this circuit makes  $\overline{\text{VCC}}$  pin turn off, or “H” after the delay time,  $t_{\text{DELAY}}$  from when the VCC power supply pin becomes equal or more than  $+V_{\text{DET}}$ . BAT power supply monitoring circuit equipped with internal registers configured to record any drop in supply voltage below a certain threshold value. Supply voltage monitoring threshold is  $V_{\text{DET}_B}$ .

The R2262x incorporates an oscillation halt sensing circuit equipped with internal registers configured to record any past oscillation halt.

Power on reset function reset the control registers when the system is powered on from 0V. At the same time, the fact is memorized to the register as a flag, thereby identifying whether they are powered on from 0V or battery backed-up.

The oscillation halt sensing circuit and the power-on reset flag are configured to confirm the established invalidation of time data in contrast to the supply voltage monitoring circuit intended to confirm the potential invalidation of time data. Further, the supply voltage monitoring circuit can be applied to battery supply voltage monitoring.

### **Periodic Interrupt Function**

The R2262x incorporates the periodic interrupt circuit configured to generate periodic interrupt signals aside from interrupt signals generated by the alarm interrupt circuit for output from the  $\overline{\text{INTR}}$  pin. Periodic interrupt signals have five selectable frequency settings of 2 Hz (once per 0.5 seconds), 1 Hz (once per 1 second), 1/60 Hz (once per 1 minute), 1/3600 Hz (once per 1 hour), and monthly (the first day of every month). Further, periodic interrupt signals also have two selectable waveforms, a normal pulse form (with a frequency of 2 Hz or 1 Hz) and special form adapted to interruption from the CPU in the level mode (with second, minute, hour, and month interrupts). The condition of periodic interrupt signals can be monitored with using a polling function. R2262Txx has the periodic interrupt registers, but does not have  $\overline{\text{INTR}}$  output pin.

### **32kHz Clock Output**

The R2262x incorporates a 32-kHz clock circuit configured to generate clock pulses with the oscillation frequency of a 32.768kHz quartz crystal unit for output from the CLKOUT pin (CMOS push-pull output). The 32-kHz clock output is always enabled and the “H” level of the CLKOUT pin is same as VCC power supply. R2262Txx does not have CLKOUT output pin.

### **User SRAM**

The R2262x provides 1byte user SRAM. The SRAM will continue to operate in battery backup mode.

## ADDRESS MAPPING

	Address [A3:A0]	Register Name	Data <sup>(1)</sup>								Default <sup>(2)</sup>
			D7	D6	D5	D4	D3	D2	D1	D0	
0	[0000]	Second Counter	- <sup>(3)</sup>	S40	S20	S10	S8	S4	S2	S1	xxh
1	[0001]	Minute Counter	-	M40	M20	M10	M8	M4	M2	M1	xxh
2	[0010]	Hour Counter	-	-	H20 P/ $\bar{A}$	H10	H8	H4	H2	H1	xxh
3	[0011]	Day-of-week Counter	-	-	-	-	-	W4	W2	W1	xxh
4	[0100]	Day-of-month Counter	-	-	D20	D10	D8	D4	D2	D1	xxh
5	[0101]	Month Counter and Century Bit	-	-	-	MO10	MO8	MO4	MO2	MO1	xxh
6	[0110]	Year Counter	Y80	Y40	Y20	Y10	Y8	Y4	Y2	Y1	xxh
7	[0111]	Oscillation Adjustment Register <sup>(4)</sup>	DEV <sup>(5)</sup>	F6	F5	F4	F3	F2	F1	F0	00h
8	[1000]	Alarm_W (Minute Register)	-	WM40	WM20	WM10	WM8	WM4	WM2	WM1	xxh
9	[1001]	Alarm_W (Hour Register)	-	-	WH20 W/ $\bar{A}$	WH10	WH8	WH4	WH2	WH1	xxh
A	[1010]	Alarm_W (Day-of-week Register)	-	WW6	WW5	WW4	WW3	WW2	WW1	WW0	xxh
B	[1011]	Alarm_D (Minute Register)	-	DM40	DM20	DM10	DM8	DM4	DM2	DM1	xxh
C	[1100]	Alarm_D (Hour Register)	-	-	DH20 D/ $\bar{A}$	DH10	DH8	DH4	DH2	DH1	xxh
D	[1101]	User SRAM	RAM7	RAM6	RAM5	RAM4	RAM3	RAM2	RAM1	RAM0	00h
E	[1110]	Control Register 1 <sup>(3)</sup>	WALE	DALE	$\bar{12}$ /24	SW2C <sup>(6)</sup>	TEST	CT2	CT1	CT0	00h
F	[1111]	Control Register 2 <sup>(3)</sup>	SCRA- TCH1	VDET	XSTP	PON <sup>(7)</sup>	SCRA- TCH2	CTFG	WAFG	DAFG	70h

<sup>(1)</sup> All the data listed above accept both reading and writing.

<sup>(2)</sup> Default value means read / written values when the PON bit is set to "1" due to VRG power-on from 0 volt. "xxh" means indefinite.

<sup>(3)</sup> The data marked with "-" is invalid for writing and reset to 0 for reading.

<sup>(4)</sup> When the PON bit is set to 1 in Control Register 2, all the bits are reset to 0 in Oscillation Adjustment Register, Control Register 1 and Control Register 2 excluding the XSTP bit and VDET bit.

<sup>(5)</sup> When DEV=0, the oscillation adjustment circuit is configured to allow correction of a time count gain or loss up to  $\pm 1.5$ ppm. When DEV=1, the oscillation adjustment circuit is configured to allow correction of a time count gain or loss up to or  $\pm 0.5$ ppm.

<sup>(6)</sup> SW2C bit is used to control SW2 between BAT and VRG.

<sup>(7)</sup> PON is a power-on-reset flag.

## REGISTER SETTINGS

### Control Register 1 (Address: Eh)

D7	D6	D5	D4	D3	D2	D1	D0	
WALE	DALE	$\overline{12}/24$	SW2C	TEST	CT2	CT1	CT0	(For Writing)
WALE	DALE	$\overline{12}/24$	SW2C	TEST	CT2	CT1	CT0	(For Reading)
0	0	0	0	0	0	0	0	Default Value <sup>(1)</sup>

#### (1) WALE, DALE Alarm\_W Enable Bit, Alarm\_D Enable Bit

WALE, DALE	Description	
0	Disabling the alarm interrupt circuit (under the control of the settings of the Alarm_W registers and the Alarm_D registers).	(Default)
1	Enabling the alarm interrupt circuit (under the control of the settings of the Alarm_W registers and the Alarm_D registers)	

#### (2) $\overline{12}/24$ $\overline{12}/24$ -hour Mode Selection Bit

$\overline{12}/24$	Description	
0	Selecting the 12-hour mode with a.m. and p.m. indications.	(Default)
1	Selecting the 24-hour mode	

Setting the  $\overline{12}/24$  bit to 0 and 1 specifies the 12-hour mode and the 24-hour mode, respectively.

24-hour mode	12-hour mode	24-hour mode	12-hour mode
00	12 (AM12)	12	32 (PM12)
01	01 (AM 1)	13	21 (PM 1)
02	02 (AM 2)	14	22 (PM 2)
03	03 (AM 3)	15	23 (PM 3)
04	04 (AM 4)	16	24 (PM 4)
05	05 (AM 5)	17	25 (PM 5)
06	06 (AM 6)	18	26 (PM 6)
07	07 (AM 7)	19	27 (PM 7)
08	08 (AM 8)	20	28 (PM 8)
09	09 (AM 9)	21	29 (PM 9)
10	10 (AM10)	22	30 (PM10)
11	11 (AM11)	23	31 (PM11)

Setting the  $\overline{12}/24$  bit should precede writing time data

<sup>(1)</sup> Default value means read / written values when the PON bit is set to "1" due to VRG power-on from 0 volt.

---

**R2262x**

---

NO.EA-226-160701

**(3) SW2C SW2 Control Bit**

SW2C	Description	(Default)
0	Regardless of the voltage VCC, SW2 = on	(Default)
1	When VCC>+VDET1 is true, SW2 turns off. When VCC<-VDET1 is true, SW2 turns on.	

The relation among SW2, power sources (VCC and BAT), and SW2C is shown in the next table. If the user needs to turn off SW2 such that a current consumption is measured at test, this bit must be set. However, default setting must be "0".

VCC	BAT	SW2C	SW1	SW2	Comment
OPEN (0.0V)	0.0v →3.0v	indefinite →0	indefinite →off	indefinite →on	After supplying BAT power, (PON=1), SW2C=0(SW2=on) is set, when VCC<-VDET1 becomes true, SW1=off is realized.
0.0V →3.3V	0.0V	indefinite →0	indefinite →on	indefinite →on	After supplying VCC power, (PON=1), SW2C=0(SW2=on) is set, when VCC>-VDET1 becomes true, SW1=on is realized and charging the secondary battery starts.
3.3V →0.0V	3.0V	0	on →off	on	With attachment of BAT power, when VCC<-VDET1 is true, SW1=off is realized, and discharging from the secondary battery starts.
0.0V →3.3V	3.0V	0	off →on	on	With attachment of BAT power, when VCC>+VDET1 is true, SW1=on is realized and status is changed from discharging the secondary battery into charging the secondary battery.
3.3V →0.0V	3.0V	1	on →off	off →on	When SW2C=1 is set, and with attachment of BAT power, when VCC<-VDET1 is true, SW1=off is realized, at the same time, SW2 turns on, and discharging from the secondary battery starts.
0.0v →3.3v	3.0v	1	off →on	on →off	When SW2C=1 is set, and with BAT power, when VCC>+VDET1 is true, SW1=on is realized, at the same time, SW2 turns off. At this moment, the connection between the secondary battery and VCC is cut off, therefore, the current measurement of VCC without charging current of secondary battery is possible.

**(4) TEST Test Bit**

TEST	Description	(Default)
0	Normal operation mode.	(Default)
1	Test mode.	

The TEST bit is used only for testing in the factory and should normally be set to 0.



**(5) CT2, CT1, and CT0 Periodic Interrupt Selection Bits**

CT2	CT1	CT0	Description		
			Wave Form Mode	Interrupt Cycle and Falling Timing	
0	0	0	-	OFF(H)	(Default)
0	0	1	-	Fixed at "L"	
0	1	0	Pulse Mode	2Hz (Duty50%)	
0	1	1	Pulse Mode	1Hz (Duty50%)	
1	0	0	Level Mode	Once per 1 second (Synchronized with second counter increment)	
1	0	1	Level Mode	Once per 1 minute (at 00 seconds of every minute)	
1	1	0	Level Mode	Once per hour (at 00 minutes and 00 seconds of every hour)	
1	1	1	Level Mode	Once per month (at 00 hours, 00 minutes, and 00 seconds of first day of every month)	

**Pulse Mode**

2-Hz and 1-Hz clock pulses are output in synchronization with the increment of the second counter as illustrated in the timing chart below.

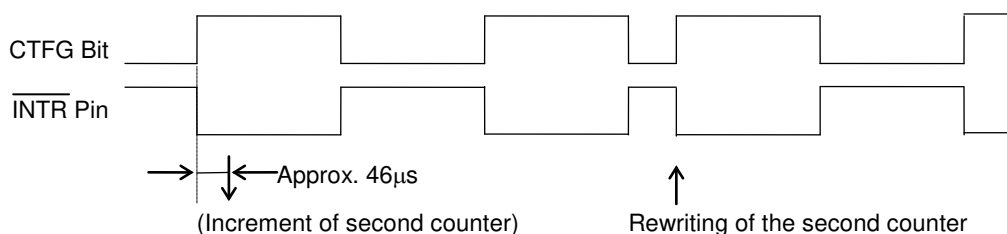

In the pulse mode, the increment of the second counter is delayed by approximately 46  $\mu$ s from the falling edge of clock pulses. Consequently, time readings immediately after the falling edge of clock pulses may appear to lag behind the time counts of the real-time clocks by approximately 1 second. Rewriting the second counter will reset the other time counters of less than 1 second, driving the  $\overline{\text{INTR}}$  pin low.

**Level Mode**

Periodic interrupt signals are output with selectable interrupt cycle settings of 1 second, 1 minute, 1 hour, and 1 month. The increment of the second counter is synchronized with the falling edge of periodic interrupt signals. For example, periodic interrupt signals with an interrupt cycle setting of 1 second are output in synchronization with the increment of the second counter as illustrated in the timing chart below.

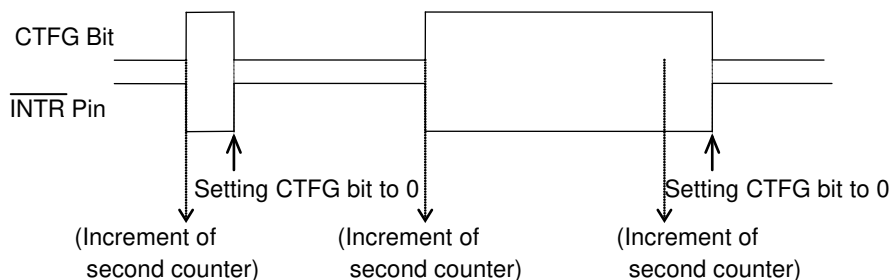

---

**R2262x**

---

NO.EA-226-160701

At the level mode, the moment right after writing CT2-CT0,  $\overline{\text{INTR}}$  pin becomes "L" in very short moment. In such a case, ignore it or confirm it by CTFG bit.

When the oscillation adjustment circuit is used, the interrupt cycle will fluctuate once per 20sec. or 60sec. as follows:

**Pulse Mode:** The "L" period of output pulses will increment or decrement by a maximum of  $\pm 3.784$  ms.

For example, 1-Hz clock pulses will have a duty cycle of  $50 \pm 0.3784\%$ .

**Level Mode:** A periodic interrupt cycle of 1 second will increment or decrement by a maximum of  $\pm 3.784$  ms.

**Control Register 2 (Address: Fh)**

D7	D6	D5	D4	D3	D2	D1	D0	
SCRAT CH1	VDET	XSTP	PON	SCRA TCH2	CTFG	WAFG	DAFG	(For Writing)
SCRAT CH1	VDET	XSTP	PON	SCRA TCH2	CTFG	WAFG	DAFG	(For Reading)
0	1	1	1	0	0	0	0	Default Value <sup>(1)</sup>

**(1) SCRATCH1 Scratch Bit 1**

SCRATCH1	Description	
0		(Default)
1		

The SCRATCH1 bit is intended for scratching and accepts the reading and writing of 0 and 1.

The SCRATCH1 bit will be set to 0 when the PON bit is set to 1 in the Control Register 1.

**(2) VDET Supply Voltage Monitoring Result Indication Bit**

VDET	Description	
0	Indicating supply voltage above the supply voltage monitoring threshold settings.	(Default)
1	Indicating supply voltage below the supply voltage monitoring threshold settings.	

Once the VDET bit is set to 1, the supply voltage monitoring circuit will be disabled while the VDET bit will hold the setting of 1. The VDET bit accepts only the writing of 0, which restarts the supply voltage monitoring circuit. Conversely, setting the VDET bit to 1 causes no event.

**(3) XSTP Oscillation Halt Sensing Monitor Bit**

XSTP	Description	
0	Sensing a normal condition of oscillation	(Default)
1	Sensing a halt of oscillation	

The XSTP bit will be set to "1" when the oscillation halt is detected. Once this bit becomes "1", unless otherwise "0" is written, this bit never return to "0". If "1" is written, nothing will change.

---

<sup>(1)</sup> Default value means read / written values when the PON bit is set to "1" due to VRG power-on from 0 volt.

---

**(4) PON Power-on-reset Flag Bit**

PON	Description
0	Normal condition
1	Detecting VRG power-on -reset

(Default)

The PON bit is for sensing power-on reset condition.

- \* The PON bit will be set to 1 when VRG power-on from 0 volt. The PON bit will hold the setting of 1 even after power-on.
- \* When the PON bit is set to 1, all bits will be reset to 0, in the Oscillation Adjustment Register, Control Register1, and Control Register 2, except PON, XSTP and VDET. As a result,  $\overline{\text{INTR}}$  pin stops outputting.
- \* The PON bit accepts only the writing of 0. Conversely, setting the PON bit to 1 causes no event.

**(5) SCRATCH1 Scratch Bit 2**

SCRATCH2	Description
0	
1	

(Default)

The SCRATCH2 bit is intended for scratching and accepts the reading and writing of 0 and 1.

The SCRATCH2 bit will be set to 0 when the PON bit is set to 1 in the Control Register 1.

**(6) CTFG Periodic Interrupt Flag Bit**

CTFG	Description
0	Periodic interrupt output = "H"
1	Periodic interrupt output = "L"

(Default)

The CTFG bit is set to 1 when the periodic interrupt signals are output from the  $\overline{\text{INTR}}$  pin ("L"). The CTFG bit accepts only the writing of 0 in the level mode, which disables ("H") the  $\overline{\text{INTR}}$  pin until it is enabled ("L") again in the next interrupt cycle. Conversely, setting the CTFG bit to 1 causes no event.

R2262Txx has CTFG bit, but does not have  $\overline{\text{INTR}}$  output pin.

**(7) WAFG,DAFG Alarm\_W Flag Bit and Alarm\_D Flag Bit**

WAFG,DAFG	Description
0	Indicating a mismatch between current time and preset alarm time
1	Indicating a match between current time and preset alarm time

(Default)

The WAFG and DAFG bits are valid only when the WALE and DALE have the setting of 1, which is caused approximately 15 $\mu$ s after any match between current time and preset alarm time specified by the Alarm\_W registers and the Alarm\_D registers. The WAFG (DAFG) bit accepts only the writing of 0.

$\overline{\text{INTR}}$  pin outputs off ("H") when this bit is set to 0. And  $\overline{\text{INTR}}$  pin outputs "L" again at the next preset alarm time. Conversely, setting the WAFG and DAFG bits to 1 causes no event. The WAFG and DAFG bits will have the reading of 0 when the alarm interrupt circuit is disabled with the WALE and DALE bits set to 0. The settings of the WAFG and DAFG bits are synchronized with the output of the  $\overline{\text{INTR}}$  pin as shown in the timing chart below.

R2262Txx has WAFG bit and DAFG bit, but does not have  $\overline{\text{INTR}}$  output pin.

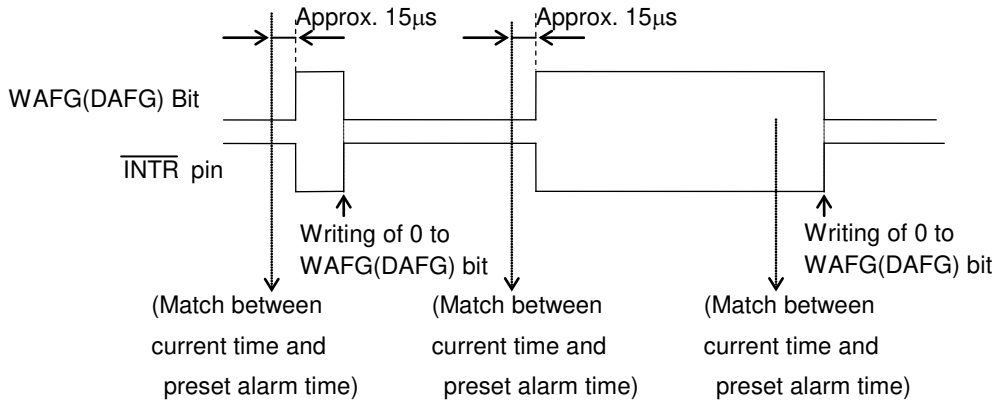

**Time Counter (Address: 0-2h)**

Second Counter (Address 0h)

D7	D6	D5	D4	D3	D2	D1	D0	
-	S40	S20	S10	S8	S4	S2	S1	(For Writing)
0	S40	S20	S10	S8	S4	S2	S1	(For Reading)
0	Indefinite	Indefinite	Indefinite	Indefinite	Indefinite	Indefinite	Indefinite	Default Value <sup>(1)</sup>

Minute Counter (Address 1h)

D7	D6	D5	D4	D3	D2	D1	D0	
-	M40	M20	M10	M8	M4	M2	M1	(For Writing)
0	M40	M20	M10	M8	M4	M2	M1	(For Reading)
0	Indefinite	Indefinite	Indefinite	Indefinite	Indefinite	Indefinite	Indefinite	Default Value <sup>(1)</sup>

Hour Counter (Address 2h)

D7	D6	D5	D4	D3	D2	D1	D0	
-	-	P/ A or H20	H10	H8	H4	H2	H1	(For Writing)
0	0	P/ A or H20	H10	H8	H4	H2	H1	(For Reading)
0	0	Indefinite	Indefinite	Indefinite	Indefinite	Indefinite	Indefinite	Default Value <sup>(1)</sup>

\* Time digit display (BCD format) as follows:

The second digits range from 00 to 59 and are carried to the minute digit in transition from 59 to 00.

The minute digits range from 00 to 59 and are carried to the hour digits in transition from 59 to 00.

The hour digits range as shown in " (2) 12 /24: 12 /24 -hour Mode Selection Bit in Control Register 1 (Address: Eh)" and are carried to the day-of-month and day-of-week digits in transition from PM11 to AM12 or from 23 to 00.

\* Any writing to the second counter resets divider units of less than 1 second.

\* Any carry from lower digits with the writing of non-existent time may cause the time counters to malfunction. Therefore, such incorrect writing should be replaced with the writing of existent time data.

<sup>(1)</sup> Default value means read / written values when the PON bit is set to "1" due to VRG power-on from 0 volt.

**Day-of-week Counter (Address 3h)**

D7	D6	D5	D4	D3	D2	D1	D0	
-	-	-	-	-	W4	W2	W1	(For Writing)
0	0	0	0	0	W4	W2	W1	(For Reading)
0	0	0	0	0	Indefinite	Indefinite	Indefinite	Default Value <sup>(1)</sup>

\* The day-of-week counter is incremented by 1 when the day-of-week digits are carried to the day-of-month digits.

\* Day-of-week display (incremented in septimal notation):

(W4, W2, W1) = (0, 0, 0) → (0, 0, 1) → ... → (1, 1, 0) → (0, 0, 0)

\* Correspondence between days of the week and the day-of-week digits are user-definable

(e.g. Sunday = 0, 0, 0)

\* The writing of (1, 1, 1) to (W4, W2, W1) is prohibited except when days of the week are unused.

**Calendar Counter (Address: 4-6h)**

Day-of-month Counter (Address 4h)

D7	D6	D5	D4	D3	D2	D1	D0	
-	-	D20	D10	D8	D4	D2	D1	(For Writing)
0	0	D20	D10	D8	D4	D2	D1	(For Reading)
0	0	Indefinite	Indefinite	Indefinite	Indefinite	Indefinite	Indefinite	Default Value <sup>(1)</sup>

Month Counter + Century Bit (Address 5h)

D7	D6	D5	D4	D3	D2	D1	D0	
-	-	-	MO10	MO8	MO4	MO2	MO1	(For Writing)
0	0	0	MO10	MO8	MO4	MO2	MO1	(For Reading)
0	0	0	Indefinite	Indefinite	Indefinite	Indefinite	Indefinite	Default Value <sup>(1)</sup>

Year Counter (Address 6h)

D7	D6	D5	D4	D3	D2	D1	D0	
Y80	Y40	Y20	Y10	Y8	Y4	Y2	Y1	(For Writing)
Y80	Y40	Y20	Y10	Y8	Y4	Y2	Y1	(For Reading)
Indefinite	Indefinite	Indefinite	Indefinite	Indefinite	Indefinite	Indefinite	Indefinite	Default Value <sup>(1)</sup>

\* The calendar counters are configured to display the calendar digits in BCD format by using the automatic calendar function as follows:

The day-of-month digits (D20 to D1) range from 1 to 31 for January, March, May, July, August, October, and December; from 1 to 30 for April, June, September, and November; from 1 to 29 for February in leap years; from 1 to 28 for February in ordinary years. The day-of-month digits are carried to the month digits in reversion from the last day of the month to 1.

The month digits (MO10 to MO1) range from 1 to 12 and are carried to the year digits in reversion from 12 to 1.

The year digits (Y80 to Y1) range from 00 to 99 (00, 04, 08, ..., 92, and 96 in leap years) .

\* Any carry from lower digits with the writing of non-existent calendar data may cause the calendar counters to malfunction. Therefore, such incorrect writing should be replaced with the writing of existent calendar data.

<sup>(1)</sup> Default value means read / written values when the PON bit is set to "1" due to VRG power-on from 0 volt.

**Oscillation Adjustment Register (Address: 7h)**

D7	D6	D5	D4	D3	D2	D1	D0	
DEV	F6	F5	F4	F3	F2	F1	F0	(For Writing)
DEV	F6	F5	F4	F3	F2	F1	F0	(For Reading)
0	0	0	0	0	0	0	0	Default Value <sup>(1)</sup>

**DEV bit**

When DEV is set to 0, the Oscillation Adjustment Circuit operates 00, 20, 40 seconds.

When DEV is set to 1, the Oscillation Adjustment Circuit operates 00 seconds.

**F6 to F0 bits**

The Oscillation Adjustment Circuit is configured to change time counts of 1 second on the basis of the settings of the Oscillation Adjustment Register at the timing set by DEV.

The Oscillation Adjustment Circuit will not operate with the same timing (00, 20, or 40 seconds) as the timing of writing to the Oscillation Adjustment Register.

The F6 bit setting of 0 causes an increment of time counts by  $((F5, F4, F3, F2, F1, F0) - 1) \times 2$ .

The F6 bit setting of 1 causes a decrement of time counts by  $((\overline{F5}, \overline{F4}, \overline{F3}, \overline{F2}, \overline{F1}, \overline{F0}) + 1) \times 2$ .

The settings of "\*", 0, 0, 0, 0, 0, "\*" ("\*" representing either "0" or "1") in the F6, F5, F4, F3, F2, F1, and F0 bits cause neither an increment nor decrement of time counts.

**Example:**

If (DEV, F6, F5, F4, F3, F2, F1, F0) is set to (0, 0, 0, 0, 0, 1, 1, 1), when the second digits read 00, 20, or 40, an increment of the current time counts of  $32768 + (7 - 1) \times 2$  to 32780 (a current time count loss).

If (DEV, F6, F5, F4, F3, F2, F1, F0) is set to (0, 0, 0, 0, 0, 0, 0, 1), when the second digits read 00, 20, 40, neither an increment nor a decrement of the current time counts of 32768.

If (DEV, F6, F5, F4, F3, F2, F1, F0) is set to (1, 1, 1, 1, 1, 1, 1, 0), when the second digits read 00, a decrement of the current time counts of  $32768 + (-2) \times 2$  to 32764 (a current time count gain).

An increase of two clock pulses once per 20 seconds causes a time count loss of approximately 3 ppm ( $2 / (32768 \times 20) = 3.051$  ppm). Conversely, a decrease of two clock pulses once per 20 seconds causes a time count gain of 3 ppm. Consequently, when DEV is set to "0", deviations in time counts can be corrected with a precision of  $\pm 1.5$  ppm. In the same way, when DEV is set to "1", deviations in time counts can be corrected with a precision of  $\pm 0.5$  ppm. Note that the oscillation adjustment circuit is configured to correct deviations in time counts and not the oscillation frequency of the 32.768-kHz clock pulses. For further details, see "*Oscillation Adjustment Circuit in Configuration of Oscillation Circuit and Correction of Time Count Deviations*".

---

<sup>(1)</sup> Default value means read / written values when the PON bit is set to "1" due to VRG power-on from 0 volt.

---

**Alarm\_W Registers (Address: 8-Ah)**

Alarm\_W Minute Register (Address 8h)

D7	D6	D5	D4	D3	D2	D1	D0	
-	WM40	WM20	WM10	WM8	WM4	WM2	WM1	(For Writing)
0	WM40	WM20	WM10	WM8	WM4	WM2	WM1	(For Reading)
0	Indefinite	Indefinite	Indefinite	Indefinite	Indefinite	Indefinite	Indefinite	Default Value <sup>(1)</sup>

Alarm\_W Hour Register (Address 9h)

D7	D6	D5	D4	D3	D2	D1	D0	
-	-	WH20 WP/ $\bar{A}$	WH10	WH8	WH4	WH2	WH1	(For Writing)
0	0	WH20 WP/ $\bar{A}$	WH10	WH8	WH4	WH2	WH1	(For Reading)
0	0	Indefinite	Indefinite	Indefinite	Indefinite	Indefinite	Indefinite	Default Value <sup>(1)</sup>

Alarm\_W Day-of-week Register (Address Ah)

D7	D6	D5	D4	D3	D2	D1	D0	
-	WW6	WW5	WW4	WW3	WW2	WW1	WW0	(For Writing)
0	WW6	WW5	WW4	WW3	WW2	WW1	WW0	(For Reading)
0	Indefinite	Indefinite	Indefinite	Indefinite	Indefinite	Indefinite	Indefinite	Default Value <sup>(1)</sup>

- \* The D5 bit of the Alarm\_W Hour Register represents WP/ $\bar{A}$  when the 12-hour mode is selected (0 for a.m. and 1 for p.m.) and WH20 when the 24-hour mode is selected (tens in the hour digits).
- \* The Alarm\_W Registers should not have any non-existent alarm time settings.  
(Note that any mismatch between current time and preset alarm time specified by the Alarm\_W registers may disable the alarm interrupt circuit.)
- \* When the 12-hour mode is selected, the hour digits read 12 and 32 for 0 a.m. and 0 p.m., respectively.  
(See " (2) 12 /24: 12 /24-hour Mode Selection Bit in Control Register 1 (Address Eh) ")
- \* WW0 to WW6 correspond to W4, W2, and W1 of the day-of-week counter with settings ranging from (0, 0, 0) to (1, 1, 0).
- \* WW0 to WW6 with respective settings of 0 disable the outputs of the Alarm\_W Registers.

<sup>(1)</sup> Default value means read / written values when the PON bit is set to "1" due to VRG power-on from 0 volt.

## R2262x

NO.EA-226-160701

### Example of Alarm Time Setting

Alarm Preset alarm time	Day-of-Week							12-Hour Mode				24-Hour Mode			
	Sun. WW0	Mon. WW1	Tue. WW2	Wed. WW3	Th. WW4	Fri. WW5	Sat. WW6	10hr.	1hr.	10min.	1min.	10hr.	1hr.	10min.	1min.
00:00 a.m. on all days	1	1	1	1	1	1	1	1	2	0	0	0	0	0	0
01:30 a.m. on all days	1	1	1	1	1	1	1	0	1	3	0	0	1	3	0
11:59 a.m. on all days	1	1	1	1	1	1	1	1	1	5	9	1	1	5	9
00:00 p.m. on Mon. to Fri.	0	1	1	1	1	1	0	3	2	0	0	1	2	0	0
01:30 p.m. on Sun.	1	0	0	0	0	0	0	2	1	3	0	1	3	3	0
11:59 p.m. on Mon. Wed. and Fri.	0	1	0	1	0	1	0	3	1	5	9	2	3	5	9

Note that the correspondence between WW0 to WW6 and the days of the week shown in the above table is just an example and not mandatory.

### Alarm\_D Register (Address: B-Ch)

Alarm\_D Minute Register (Address Bh)

D7	D6	D5	D4	D3	D2	D1	D0	
-	DM40	DM20	DM10	DM8	DM4	DM2	DM1	(For Writing)
0	DM40	DM20	DM10	DM8	DM4	DM2	DM1	(For Reading)
0	Indefinite	Indefinite	Indefinite	Indefinite	Indefinite	Indefinite	Indefinite	Default Value <sup>(1)</sup>

Alarm\_D Hour Register (Address Ch)

D7	D6	D5	D4	D3	D2	D1	D0	
-	-	DH20 DP/ $\bar{A}$	DH10	DH8	DH4	DH2	DH1	(For Writing)
0	0	DH20 DP/ $\bar{A}$	DH10	DH8	DH4	DH2	DH1	(For Reading)
0	0	Indefinite	Indefinite	Indefinite	Indefinite	Indefinite	Indefinite	Default Value <sup>(1)</sup>

\* The D5 bit represents DP/  $\bar{A}$  when the 12-hour mode is selected (0 for a.m. and 1 for p.m.) and DH20 when the 24-hour mode is selected (tens in the hour digits).

\* The Alarm\_D registers should not have any non-existent alarm time settings.

(Note that any mismatch between current time and preset alarm time specified by the Alarm\_D registers may disable the alarm interrupt circuit.)

\* When the 12-hour mode is selected, the hour digits read 12 and 32 for 0a.m. and 0p.m., respectively. (See " (2) 12 /24: 12 /24-hour Mode Selection Bit in Control Register 1 (Address Eh) ")

<sup>(1)</sup> Default value means read / written values when the PON bit is set to "1" due to VRG power-on from 0 volt.



## INTERFACING WITH CPU

### Data Transfer Formats

#### (1) Timing between CE Pin Transition and Data Input / Output

The R2262x adopts a 3-wire serial interface by which they use the CE (Chip Enable), SCLK (Serial Clock), and SIO (Serial Input/Output) pins to receive and send data to and from the CPU. The 3-wire serial interface provides two types of input/output timings with which the SIO pin output and input are synchronized with the rising or falling edges of the SCLK pin input, respectively, and vice versa. The R2262x is configured to select either one of two different input/output timings depending on the level of the SCLK pin in the low to high transition of the CE pin. Namely, when the SCLK pin is held low in the low to high transition of the CE pin, the models will select the timing with which the SIO pin output is synchronized with the rising edge of the SCLK pin input, and the input is synchronized with the falling edge of the SCLK pin input, as illustrated in the timing chart below.

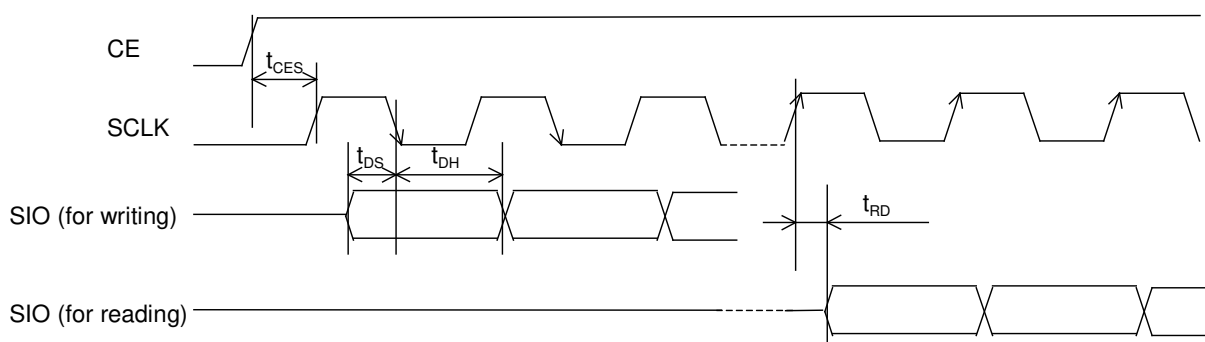

Conversely, when the SCLK pin is held high in the low to high transition of the CE pin, the models will select the timing with which the SIO pin output is synchronized with the falling edge of the SCLK pin input, and the input is synchronized with the rising edge of the SCLK pin input, as illustrated in the timing chart below.

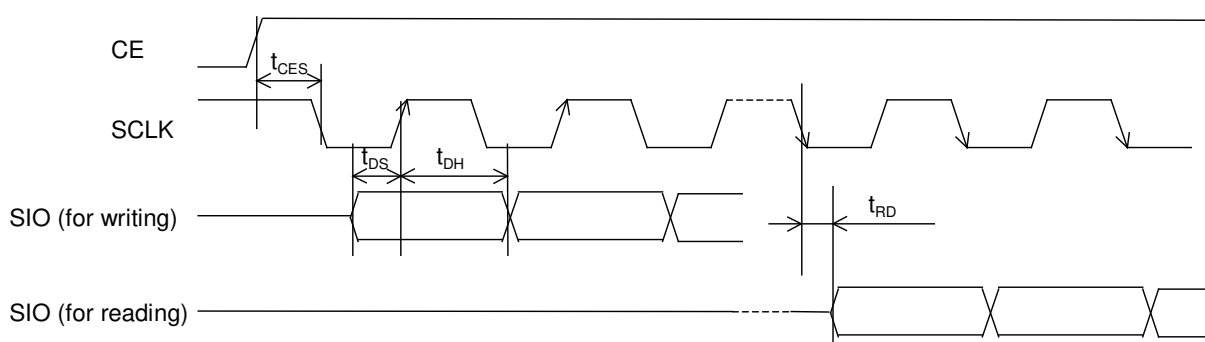

**(2) Data Transfer Formats**

Data transfer is commenced in the low to high transition of the CE pin input and completed in its high to low transition. Data transfer is conducted serially in multiple units of 1 byte (8 bits). The former 4 bits are used to specify in the Address Pointer a head address with which data transfer is to be commenced from the host. The latter 4 bits are used to select either reading data transfer or writing data transfer, and to set the Transfer Format Register to specify an appropriate data transfer format. All data transfer formats are designed to transfer the most significant bit (MSB) first.

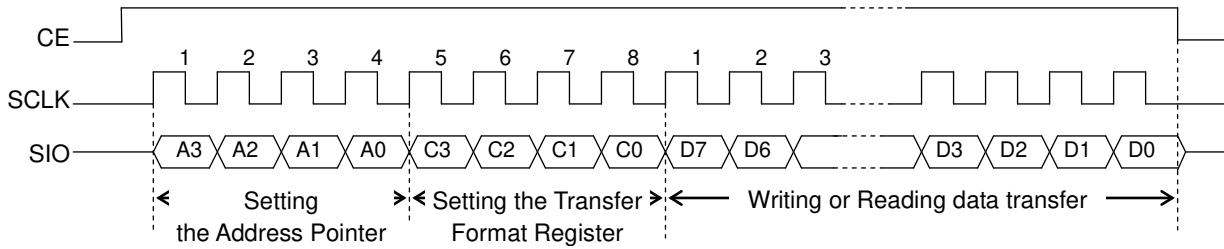

Two types of data transfer formats are available for reading data transfer and writing data transfer each.

**Writing Data Transfer Formats**

**(1) 1-byte Writing Data Transfer Format**

The first type of writing data transfer format is designed to transfer 1-byte data at a time and can be selected by specifying in the address pointer a head address with which writing data transfer is to be commenced and then writing the setting of 8h to the transfer format register. This 1-byte writing data transfer can be completed by driving the CE pin low or continued by specifying a new head address in the address pointer and setting the data transfer format.

Example of 1-byte Writing Data Transfer (For Writing Data to Addresses Fh and 7h)

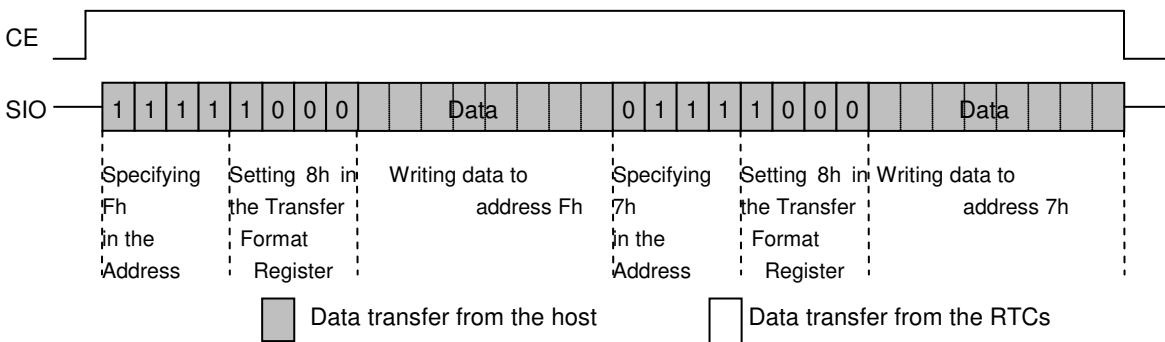

## (2) Burst Writing Data Transfer Format

The second type of writing data transfer format is designed to transfer a sequence of data serially and can be selected by specifying in the address pointer a head address with which writing data transfer is to be commenced and then writing the setting of 0h to the transfer format register. The address pointer is incremented for each transfer of 1-byte data and cycled from Fh to 0h. This burst writing data transfer can be completed by driving the CE pin low.

Example of Burst Writing Data Transfer (For Writing Data to Addresses Eh, Fh, and 0h)

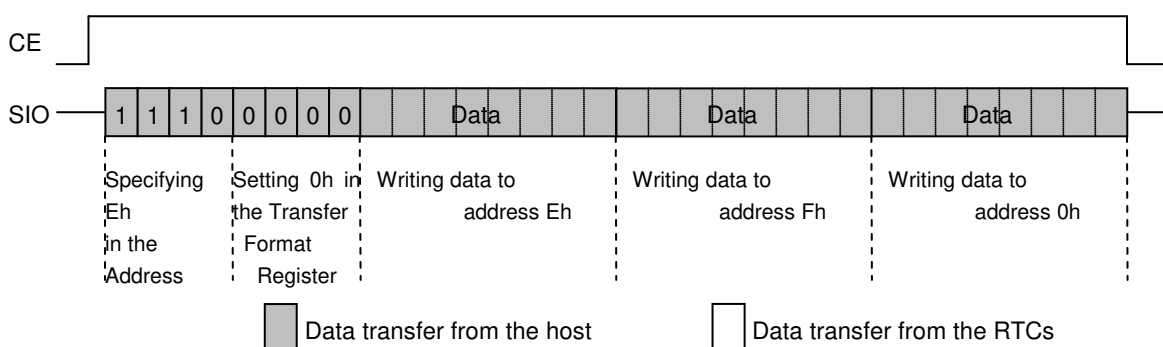

## Reading Data Transfer Formats

### (1) 1-byte Reading Data Transfer Format

The first type of reading data transfer format is designed to transfer 1-byte data at a time and can be selected by specifying in the Address Pointer a head address with which reading data transfer is to be commenced and then the setting of writing Ch to the Transfer Format Register. This 1-byte reading data transfer can be completed by driving the CE pin low or continued by specifying a new head address in the Address Pointer and selecting this type of reading data Transfer Format.

Example of 1-byte Reading Data Transfer (For Reading Data from Addresses Eh and 2h)

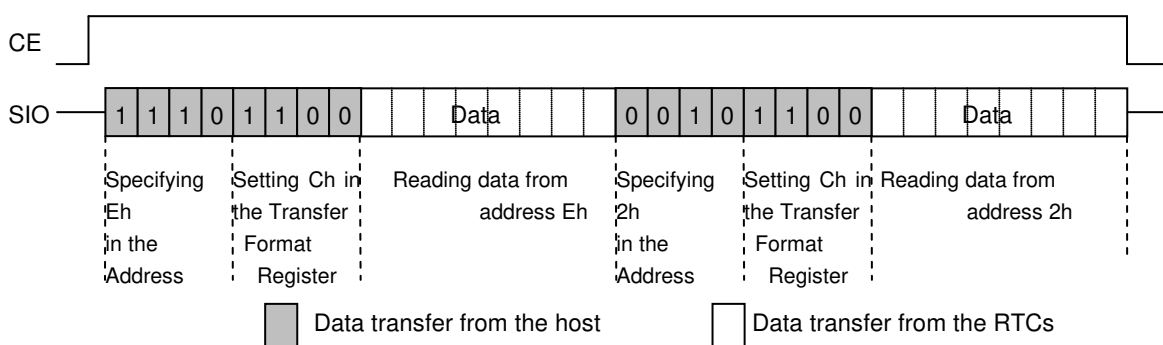

**(2) Burst Reading Data Transfer Format**

The second type of reading data transfer format is designed to transfer a sequence of data serially and can be selected by specifying in the address pointer a head address with which reading data transfer is to be commenced and then writing the setting of 4h to the transfer format register. The address pointer is incremented for each transfer of 1-byte data and cycled from Fh to 0h. This burst reading data transfer can be completed by driving the CE pin low.

Example of Burst Reading Data Transfer (For Reading Data from Addresses Fh, 0h, and 1h)

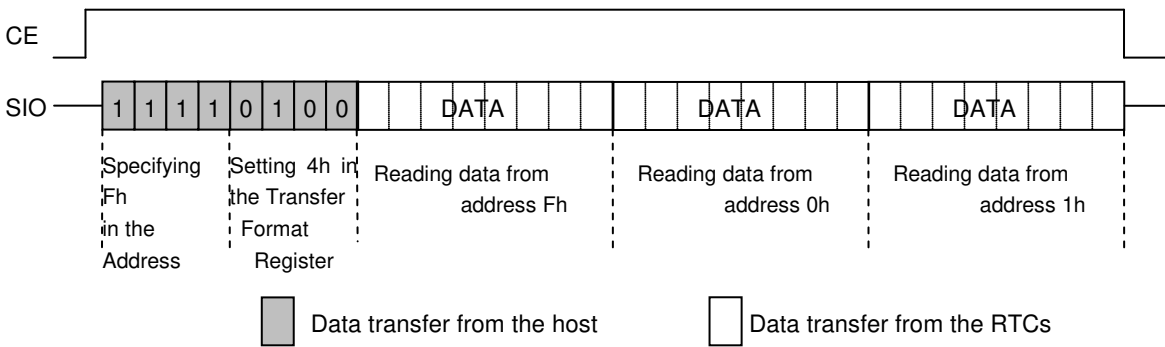

**(3) Combination of 1-byte Reading and writing Data Transfer Formats**

The 1-byte reading and writing data transfer formats can be combined together and further followed by any other data transfer format.

Example of Reading Modify Writing Data Transfer

(For Reading and Writing Data from and to Address Fh)

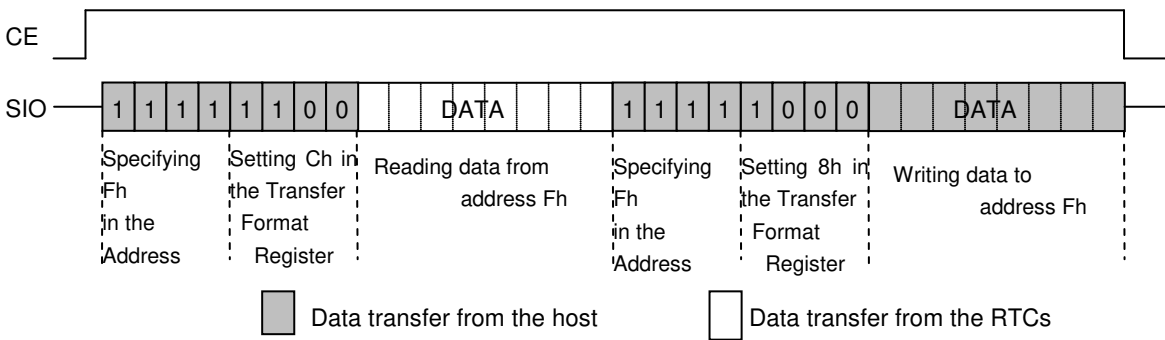

The reading and writing data transfer formats correspond to the settings in the transfer format register as shown in the table below.

	1 Byte	Burst
Writing data transfer	8h (1,0,0,0)	0h (0,0,0,0)
Reading data transfer	Ch (1,1,0,0)	4h (0,1,0,0)

### Considerations in Reading and Writing Time Data under Special Condition

Any carry to the second digits in the process of reading or writing time data may cause reading or writing erroneous time data. For example, suppose a carry out of 13:59:59 into 14:00:00 occurs in the process of reading time data in the middle of shifting from the minute digits to the hour digits. At this moment, the second digits, the minute digits, and the hour digits read 59 seconds, 59 minutes, and 14 hours, respectively (indicating 14:59:59) to cause the reading of time data deviating from actual time virtually 1 hour. A similar error also occurs in writing time data. To prevent such errors in reading and writing time data, the R2262x has the function of temporarily locking any carry to the second digits during the high interval of the CE pin and unlocking such a carry in its high to low transition. Note that a carry to the second digits can be locked for only 1 second, during which time the CE pin should be driven low.

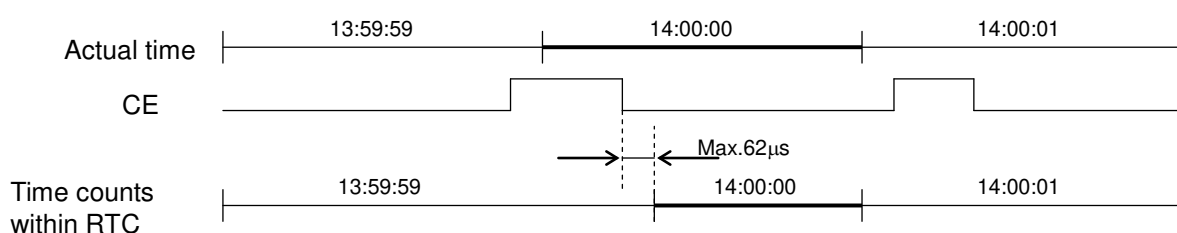

The effective use of this function requires the following considerations in reading and writing time data:

- 1) Hold the CE pin high in each session of reading or writing time data.
- 2) Ensure that the high interval of the CE pin lasts within 1 second. Should there be any possibility of the host going down in the process of reading or writing time data, make arrangements in the peripheral circuitry as to drive the CE pin low or open at the moment that the host actually goes down.
- 3) Leave a time span of 31µs or more from the low to high transition of the CE pin to the start of access to addresses 0h to 6h in order that any ongoing carry of the time digits may be completed within this time span.

For further details, see the next page.

- 4) Leave a time span of 62µs or more from the high to low transition of the CE pin to its low to high transition in order that any ongoing carry of the time digits during the high interval of the CE pin may be adjusted within this time span.

The considerations listed in 1), 3), and 4) above are not required when the process of reading or writing time data is obviously free from any carry of the time digits.

(e.g. reading or writing time data in synchronization with the periodic interrupt function in the level mode or the alarm interrupt function).

Bad examples of reading and writing time data are illustrated on the next page.

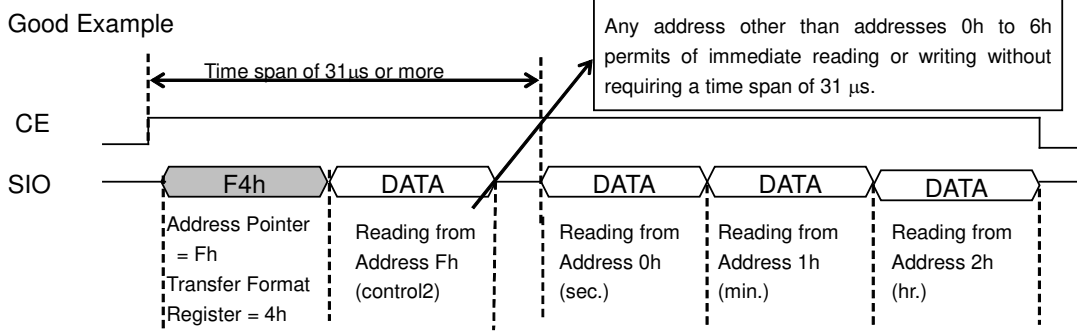

**Bad Example (1)**  
(Where the CE pin is once driven low in the process of reading time data)

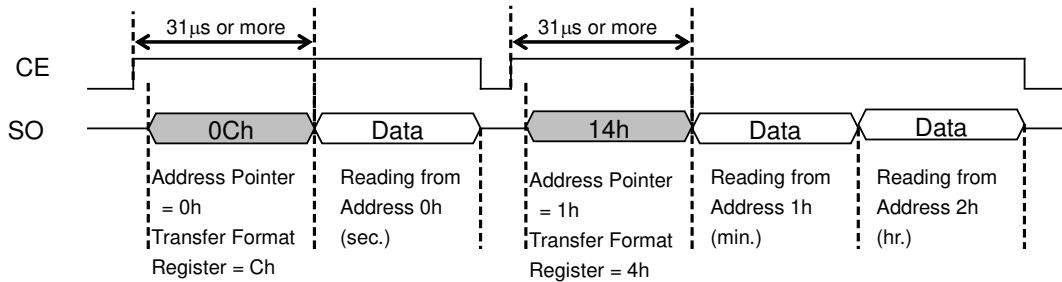

**Bad Example (2)**  
(Where a time span of less than 31µs is left until the start of the process of writing time data)

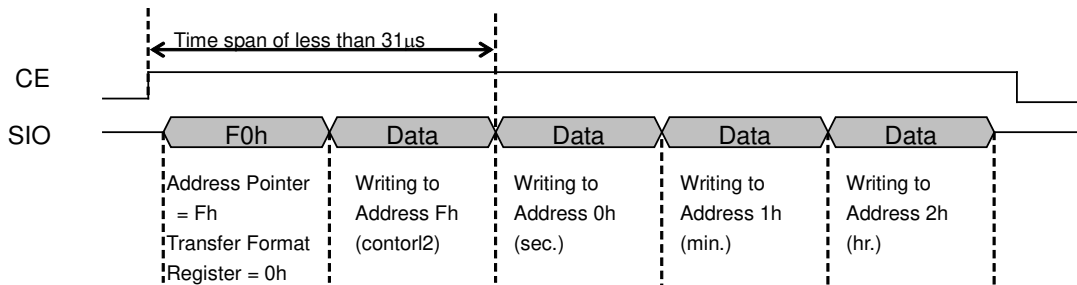

**Bad Example (3)**

(Where a time span of less than 61µs is left between the adjacent processes of reading time data)

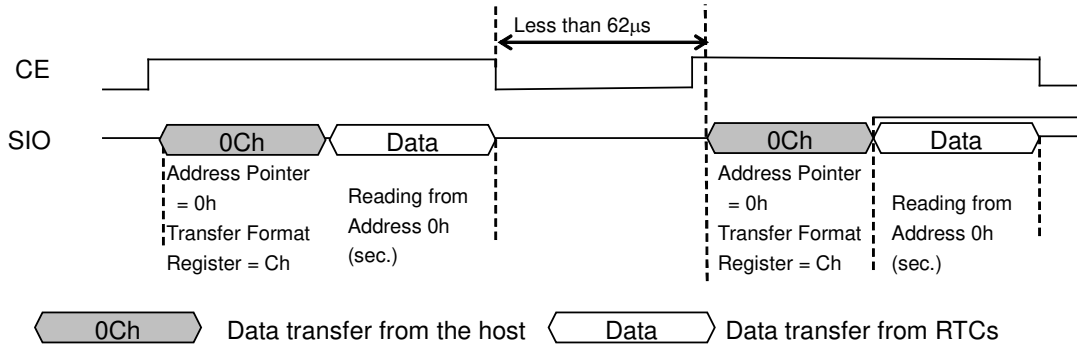

## CONFIGURATION OF OSCILLATION CIRCUIT AND CORRECTION OF TIME COUNT DEVIATIONS

### Configuration of Oscillation Circuit

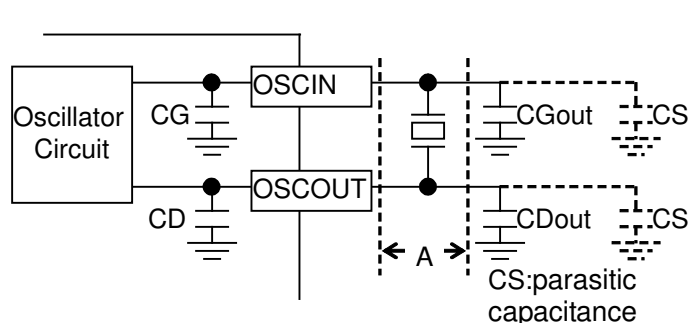

Typical externally-equipped element

X'tal : 32.768kHz

R1= under 75k $\Omega$  to 80k $\Omega$  (Max.)

CL=6pF to 8pF

Standard values of internal elements

CG, CD 10pF (Typ.)

The oscillation circuit is driven at a constant voltage of approximately 0.9 volts relative to the level of the VSS pin input. As such, it is configured to generate an oscillating waveform with a peak-to-peak voltage on the order of 0.9 volts on the positive side of the VSS pin input.

#### < Considerations in Handling Quartz Crystal Units >

Generally, quartz crystal units have basic characteristics including an equivalent series resistance (R1) indicating the ease of their oscillation and a load capacitance (CL) indicating the degree of their center frequency. Particularly, quartz crystal units intended for use in the R2262x are recommended to have a typical R1 value of under 75 to 80k $\Omega$ (Max.) and a typical CL value of 6 to 8pF. To confirm these recommended values, contact the manufacturers of quartz crystal units intended for use in these particular models.

#### < Considerations in Installing Components around the Oscillation Circuit >

- 1) Install the quartz crystal unit in the closest possible vicinity to the real-time clock ICs.
- 2) Avoid laying any signal lines or power lines in the vicinity of the oscillation circuit (particularly in the area marked "A" in the above figure).
- 3) Apply the highest possible insulation resistance between the OSCIN and OSCOUT pins and the printed circuit board.
- 4) Avoid using any long parallel lines to wire the OSCIN and OSCOUT pins.
- 5) Take extreme care not to cause condensation, which leads to various problems such as oscillation halt.

#### < Other Relevant Considerations >

- 1) We cannot recommend connecting the external input of 32.768-kHz clock pulses to the OSCIN pin.
- 2) To maintain stable characteristics of the quartz crystal unit, avoid driving any other IC through 32.768-kHz clock pulses output from the OSCOUT pin.

### Measurement of Oscillation Frequency

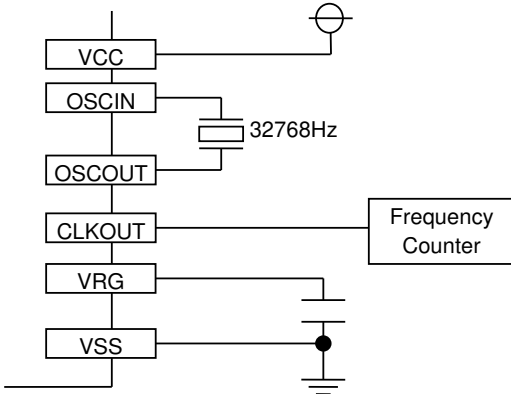

- The R2262x (Except R2262Txx) is configured to generate 32.768-kHz clock pulses for output from the CLKOUT pin.
- A frequency counter with 6 (more preferably 7) or more digits on the order of 1ppm is recommended for use in the measurement of the oscillation frequency of the oscillation circuit.

### Adjustment of Oscillation frequency

The oscillation frequency of the oscillation circuit can be adjusted by varying procedures depending on the usage of Model R2262x in the system into which they are to be built and on the allowable degree of time count errors. The flow chart below serves as a guide to selecting an optimum oscillation frequency adjustment procedure for the relevant system.

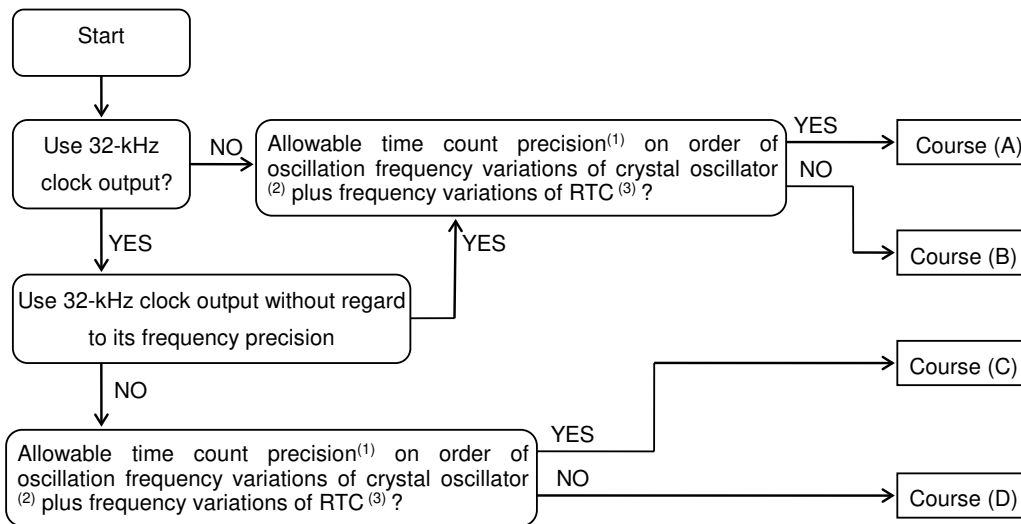

(1) Time count precision as referred to in the above flow chart is applicable to normal temperature and actually affected by the temperature characteristics and other properties of quartz crystal units.

(2) Generally, quartz crystal units for commercial use are classified in terms of their center frequency depending on their load capacitance (CL) and further divided into ranks on the order of  $\pm 10$ ,  $\pm 20$ , and  $\pm 50$ ppm depending on the degree of their oscillation frequency variations.

(3) Basically, Model R2262x is configured to cause frequency variations on the order of  $\pm 5$  to  $\pm 10$ ppm at 25°C.



**Course (A)**

When the time count precision of each RTC is not to be adjusted, the quartz crystal unit intended for use in that RTC may have any CL value requiring no presetting. The quartz crystal unit may be subject to frequency variations which are selectable within the allowable range of time count precision. Several quartz crystal units and RTCs should be used to find the center frequency of the quartz crystal units by the method described in "*Measurement of Oscillation Frequency*" and then calculate an appropriate oscillation adjustment value by the method described in "*Oscillation Adjustment Circuit*" for writing this value to the R2262x.

**Course (B)**

When the time count precision of each RTC is to be adjusted within the oscillation frequency variations of the quartz crystal unit plus the frequency variations of the real-time clock ICs, it becomes necessary to correct deviations in the time count of each RTC by the method described in "*Oscillation Adjustment Circuit*". Such oscillation adjustment provides quartz crystal units with a wider range of allowable settings of their oscillation frequency variations and their CL values. The real-time clock IC and the quartz crystal unit intended for use in that real-time clock IC should be used to find the center frequency of the quartz crystal unit by the method described in "*Measurement of Oscillation Frequency*" and then confirm the center frequency thus found to fall within the range adjustable by the oscillation adjustment circuit before adjusting the oscillation frequency of the oscillation circuit. At normal temperature, the oscillation frequency of the oscillator circuit can be adjusted by up to approximately  $\pm 0.5\text{ppm}$ .

## Course (C)

Course (C) together with Course (D) requires adjusting the time count precision of each RTC as well as the frequency of 32.768-kHz clock pulses output from the CLKOUT pin. Normally, the oscillation frequency of the crystal oscillator intended for use in the RTCs should be adjusted by adjusting the oscillation stabilizing capacitors CG and CD connected to both ends of the crystal oscillator. The R2262x, which incorporate the CG and the CD, require adjusting the oscillation frequency of the crystal oscillator through its CL value. Generally, the relationship between the CL value and the CG and CD values can be represented by the following equation:

$CL = (CG \times CD)/(CG + CD) + CS$  where "CS" represents the floating capacity of the printed circuit board.

The crystal oscillator intended for use in the R2262x is recommended to have the CL value on the order of 6 to 8pF. Its oscillation frequency should be measured by the method described in "*Measurement of Oscillation Frequency*". Any crystal oscillator found to have an excessively high or low oscillation frequency (causing a time count gain or loss, respectively) should be replaced with another one having a smaller and greater CL value, respectively until another one having an optimum CL value is selected. In this case, the bit settings disabling the oscillation adjustment circuit (see "*Oscillation Adjustment Circuit*") should be written to the oscillation adjustment register.

Incidentally, the high oscillation frequency of the crystal oscillator can also be adjusted by adding an external oscillation stabilization capacitor CGOUT<sup>(1)</sup> or/and CDOUT as illustrated in the diagram below.

---

<sup>(1)</sup> The CGout should have a capacitance ranging from 0 pF to 15 pF.

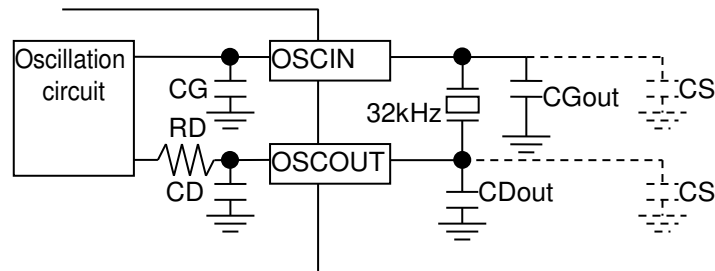
**Course (D)**

It is necessary to select the crystal oscillator in the same manner as in Course (C) as well as correct errors in the time count of each RTC in the same manner as in Course (B) by the method described in "*Oscillation Adjustment Circuit*".

**Oscillation Adjustment Circuit**

The oscillation adjustment circuit can be used to correct a time count gain or loss with high precision by varying the number of 1-second clock pulses once per 20 seconds or 60 seconds. When DEV bit in the Oscillation Adjustment Register is set to 0, R2262x varies number of 1-second clock pulses once per 20 seconds. When DEV bit is set to 1, R2262x varies number of 1-second clock pulses once per 60 seconds. The oscillation adjustment circuit can be disabled by writing the settings of "\*", 0, 0, 0, 0, 0, "\*" ("\*" representing "0" or "1") to the F6, F5, F4, F3, F2, F1, and F0 bits in the oscillation adjustment circuit. Conversely, when such oscillation adjustment is to be made, an appropriate oscillation adjustment value can be calculated by the equation below for writing to the oscillation adjustment circuit.

- |                               |  |
|-------------------------------|--|
| Oscillation frequency:        | Frequency of clock pulse output from the CLKOUT pin at normal temperature in the manner described in " <i>Measurement of Oscillation Frequency</i> ".  |
| Target frequency:             | Desired frequency to be set. Generally, a 32.768-kHz quartz crystal unit has such temperature characteristics as to have the highest oscillation frequency at normal temperature. Consequently, the quartz crystal unit is recommended to have target frequency settings on the order of 32.768 to 32.76810 kHz (+3.05ppm relative to 32.768 kHz). Note that the target frequency differs depending on the environment or location where the equipment incorporating the RTC is expected to be operated. |
| Oscillation adjustment value: | Value that is to be finally written to the F0 to F6 bits in the Oscillation Adjustment Register and is represented in 7-bit coded decimal notation.  |

**(1) When Oscillation Frequency is higher than Target Frequency (Causing Time Count Gain)**

When DEV=0:

$$\begin{aligned} \text{Oscillation adjustment value} &= (\text{Oscillation frequency} - \text{Target Frequency} + 0.1) \\ &\quad \text{Oscillation frequency} \times 3.051 \times 10^{-6} \\ &\approx (\text{Oscillation Frequency} - \text{Target Frequency}) \times 10 + 1 \end{aligned}$$

When DEV=1:

$$\begin{aligned} \text{Oscillation adjustment value} &= (\text{Oscillation frequency} - \text{Target Frequency} + 0.0333) \\ &\quad \text{Oscillation frequency} \times 1.017 \times 10^{-6} \\ &\approx (\text{Oscillation Frequency} - \text{Target Frequency}) \times 30 + 1 \end{aligned}$$

**(2) When Oscillation Frequency is equal to Target Frequency (Causing Time Count neither Gain nor Loss)**

Oscillation adjustment value = 0, +1, -64, or -63

**(3) When Oscillation Frequency is lower than Target Frequency (Causing Time Count Loss)**

When DEV=0:

$$\begin{aligned} \text{Oscillation adjustment value} &= (\text{Oscillation frequency} - \text{Target Frequency}) \\ &\quad \text{Oscillation frequency} \times 3.051 \times 10^{-6} \\ &\approx (\text{Oscillation Frequency} - \text{Target Frequency}) \times 10 \end{aligned}$$

When DEV=1:

$$\begin{aligned} \text{Oscillation adjustment value} &= (\text{Oscillation frequency} - \text{Target Frequency}) \\ &\quad \text{Oscillation frequency} \times 1.017 \times 10^{-6} \\ &\approx (\text{Oscillation Frequency} - \text{Target Frequency}) \times 30 \end{aligned}$$

Oscillation adjustment value calculations are exemplified below

(Ex. A) For an oscillation frequency = 32768.85Hz and a target frequency = 32768.05Hz

When setting DEV bit to 0:

$$\begin{aligned} \text{Oscillation adjustment value} &= (32768.85 - 32768.05 + 0.1) / (32768.85 \times 3.051 \times 10^{-6}) \\ &\approx (32768.85 - 32768.05) \times 10 + 1 \\ &= 9.001 \approx 9 \end{aligned}$$

In this instance, write the settings (DEV,F6,F5,F4,F3,F2,F1,F0)=(0,0,0,0,1,0,0,1) in the oscillation adjustment register. Thus, an appropriate oscillation adjustment value in the presence of any time count gain represents a distance from 01h.

When setting DEV bit to 1:

$$\begin{aligned} \text{Oscillation adjustment value} &= (32768.85 - 32768.05 + 0.0333) / (32768.85 \times 1.017 \times 10^{-6}) \\ &\approx (32768.85 - 32768.05) \times 30 + 1 \\ &= 25.00 \approx 25 \end{aligned}$$

In this instance, write the settings (DEV,F6,F5,F4,F3,F2,F1,F0)=(1,0,0,1,1,0,0,1) in the oscillation adjustment register.

---

**R2262x**

---

NO.EA-226-160701

(Ex. B) For an oscillation frequency = 32762.22Hz and a target frequency = 32768.05Hz

When setting DEV bit to 0:

$$\begin{aligned}\text{Oscillation adjustment value} &= (32762.22 - 32768.05) / (32762.22 \times 3.051 \times 10^{-6}) \\ &\approx (32762.22 - 32768.05) \times 10 \\ &= -58.325 \approx -58\end{aligned}$$

To represent an oscillation adjustment value of - 58 in 7-bit coded decimal notation, subtract 58 (3Ah) from 128 (80h) to obtain 46h. In this instance, write the settings of (DEV,F6,F5,F4,F3,F2,F1,F0) = (0,1,0,0,0,1,1,0) in the oscillation adjustment register. Thus, an appropriate oscillation adjustment value in the presence of any time count loss represents a distance from 80h.

When setting DEV bit to 1:

$$\begin{aligned}\text{Oscillation adjustment value} &= (32762.22 - 32768.05) / (32762.22 \times 1.017 \times 10^{-6}) \\ &\approx (32762.22 - 32768.05) \times 30 \\ &= -174.97 \approx -175\end{aligned}$$

Oscillation adjustment value can be set from -62 to 63. Then, in this case, Oscillation adjustment value is out of range.

**(4) Difference between DEV=0 and DEV=1**

Difference between DEV=0 and DEV=1 is following,

	<b>DEV=0</b>	<b>DEV=1</b>
Maximum value range	-189.2ppm to 189.2ppm	--62ppm to 63ppm
Minimum resolution	3ppm	1ppm

**How to evaluate the clock gain or loss**

The oscillator adjustment circuit is configured to change time counts of 1 second on the basis of the settings of the oscillation adjustment register once in 20 seconds or 60 seconds. The oscillation adjustment circuit does not effect the frequency of 32768Hz-clock pulse output from the CLKOUT pin. Therefore, after writing the oscillation adjustment register, we cannot measure the clock error with probing CLKOUT clock pulses. The way to measure the clock error as follows: Except R2262Tx

(1) Output a 1Hz clock pulse of Pulse Mode from the interrupt pin

Set (xxxx0011) to Control Register 1 at address Eh, then 1Hz clock with 50% duty is output from  $\overline{\text{INTR}}$  pin.

After setting the oscillation adjustment register, 1Hz clock period changes every 20 sec (DEV=0) or every 60 seconds (DEV=1) like next page figure.

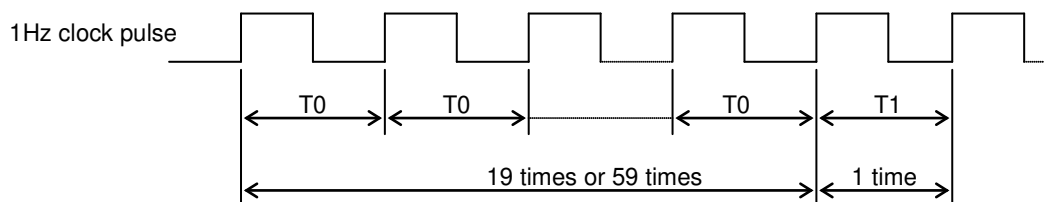

Measure the interval of  $T_0$  and  $T_1$  with frequency counter. A frequency counter with 7 or more digits is recommended for the measurement.

(2) Calculate the typical period from  $T_0$  and  $T_1$

$$\text{DEV}=0$$

$$T = (19 \times T_0 + 1 \times T_1) / 20$$

$$\text{DEV}=1$$

$$T = (59 \times T_0 + 1 \times T_1) / 60$$

Calculate the time error from  $T$ .

This method is used at the evaluation stage, however, at the mass production stage, the method is time-consuming and impractical. To confirm the result in a short time, the operation may be complicated, but time error adjustment is digital-wise. Therefore, the time gain and the loss can be estimated precisely by the calculation of 32K clock frequency and adjustment value.

## **POWER-ON RESET, OSCILLATION HALT SENSING, AND SUPPLY VOLTAGE MONITORING**

### **PON, XSTP, and VDET**

The power-on reset circuit is configured to reset control register1, 2, and clock adjustment register when VRG power up from 0v. The oscillation halt sensing circuit is configured to record a halt on oscillation by 32.768-kHz clock pulses. The supply voltage monitoring circuit is configured to record a drop in supply voltage below a threshold voltage ( $V_{DETb}$ ).

Each function has a monitor bit. For example, the PON bit is for the power-on reset circuit, and XSTP bit is for the oscillation halt sensing circuit, and VDET is for the supply voltage monitoring circuit.

XSTP bit becomes "1" when the oscillation halts. The register value is maintained until the "0" is written. It is impossible to write "1" to this XSTP bit. As for the VDET, the flag for monitoring supply voltage becomes "1" if PON, the flag for power-on reset becomes "1".

The relation among the condition of the PON, XSTP, and VDET, and power supply condition, and time data is shown in the table below.

<b>PON</b>	<b>XSTP</b>	<b>VDET</b>	<b>Conditions of Supply Voltage and Oscillation</b>	<b>Condition of Oscillator, and Back-up Status</b>
0	0	0	No drop in VRG supply voltage below threshold voltage and no halt in oscillation	Normal
0	0	1	VRG supply voltage becomes below threshold voltage, but oscillation continues.	Time data is normal. However, the back-up battery voltage becomes close to minimum voltage for time keeping.
0	1	0	Oscillation halts, however, the power supply does not become lower than the threshold	Oscillation may halt by condensation or other reasons.
0	1	1	VRG supply voltage becomes lower than the threshold voltage but higher than 0V, oscillation halts	Time function stops caused by the backup battery voltage drops.
1	1	1	Drop in supply voltage to 0V	Time data is unreliable.

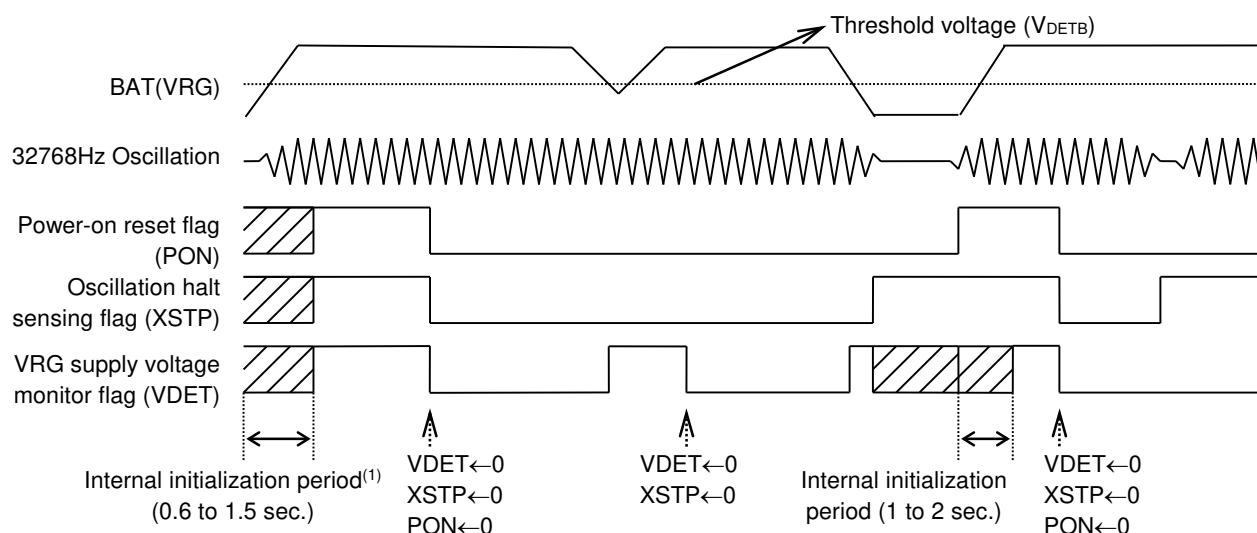

#### < Considerations in Using Oscillation Halt Sensing Circuit >

Be sure to prevent the oscillation halt sensing circuit from malfunctioning by preventing the following:

- 1) Instantaneous power-down on the VRG
- 2) Condensation on the quartz crystal unit
- 3) On-board noise to the quartz crystal unit
- 4) Applying to individual pins voltage exceeding their respective maximum ratings

In particular, note that the XSTP bit may fail to be set to 0 in the presence of any applied supply voltage as illustrated below in such events as backup battery installation. Further, give special considerations to prevent excessive chattering in the oscillation halt sensing circuit.

VRG

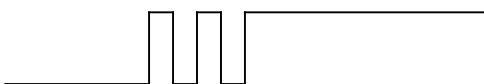

<sup>(1)</sup> The power on reset shown above is an internal signal and the signal is generated from right after the VRG turns on until the oscillation of quartz crystal unit starts. While the term of the power-on reset signal is out, or the time until the oscillation of quartz crystal unit starts, approximately 0.1s to 1.0s, access of I2C bus is impossible.

## R2262x

NO.EA-226-160701

### Voltage Monitoring Circuit

R2262x incorporates two kinds of voltage monitoring function. These are shown in the table below.

	VCC Voltage Monitoring	BAT Voltage Monitoring (VDET)
Purpose	CPU Reset Output	Back-up Battery Checker
Monitoring Supply Voltage	VCC pin	VRG pin (supply voltage for the internal RTC circuit)
Output for Monitoring Result	$\overline{\text{VDCC}}$ pin	Store in the Control Register 2 (D6 in Address Fh)
Function	The $\overline{\text{VDCC}}$ pin outputs "L" when VCC falls to a threshold voltage or less, and then SW1 becomes OFF. The $\overline{\text{VDCC}}$ pin outputs "H" after $t_{\text{DEALY}}$ when VCC rises to a threshold voltage or more, and then SW1 becomes ON.	A flag is stored in the register (D6 in address Fh).
Detector Threshold (Falling edge of power supply voltage)	$-V_{\text{DET1}}$	$V_{\text{DETB}}$
Detector Released Voltage (Rising edge of power supply voltage)	$+V_{\text{DET1}}$	Same as falling edge (No Hysteresis)
Monitoring Method	Always	One time every second

The BAT supply voltage monitoring circuit is configured to conduct a sampling operation during an interval of 7.8ms per second to check for a drop in supply voltage below a threshold voltage ( $V_{\text{DETB}}$ ), thus minimizing supply current requirements as illustrated in the timing chart below. This circuit suspends a sampling operation once the VDET bit is set to 1 in the Control Register 2. The BAT supply voltage monitor is useful for back-up battery checking.

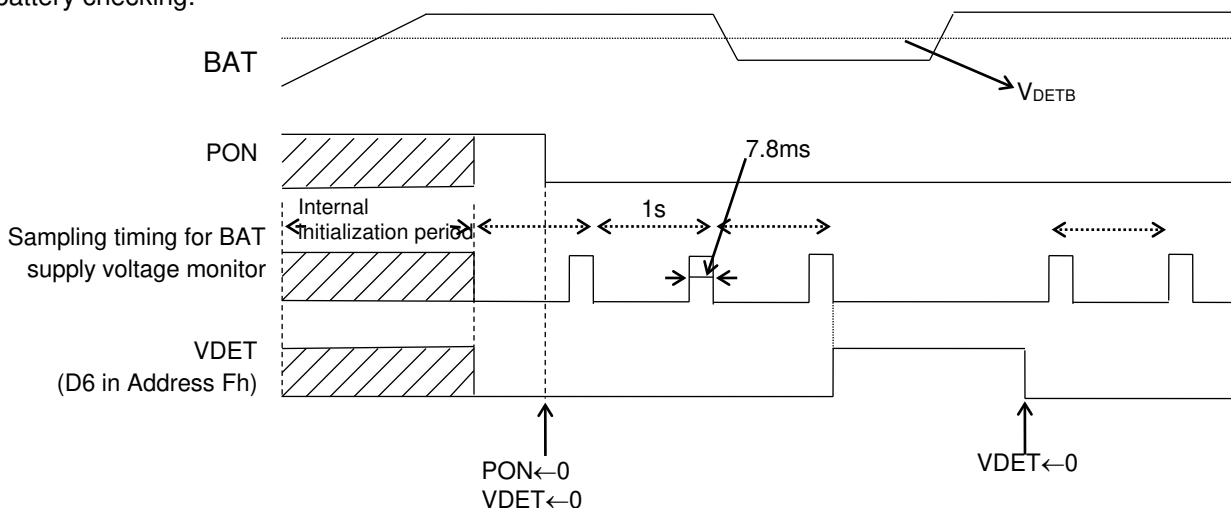

#### <Precautions for Using Voltage Monitoring Circuit>

After writing to the second counter, reset a VDET flag (writing 0) once for defining a value of VDET flag.



The VCC supply voltage monitor circuit operates always. When VCC is higher than  $+V_{DET1}$ , SW1 turns on. And  $t_{DELAY}$  after rising VCC,  $\overline{VDCC}$  outputs OFF(H). But when oscillation is halt, VCC outputs OFF(H)  $t_{DELAY}$  after oscillation starting. When VCC is lower than  $-V_{DET1}$ , SW1 turns off. And  $\overline{VDCC}$  outputs "L".

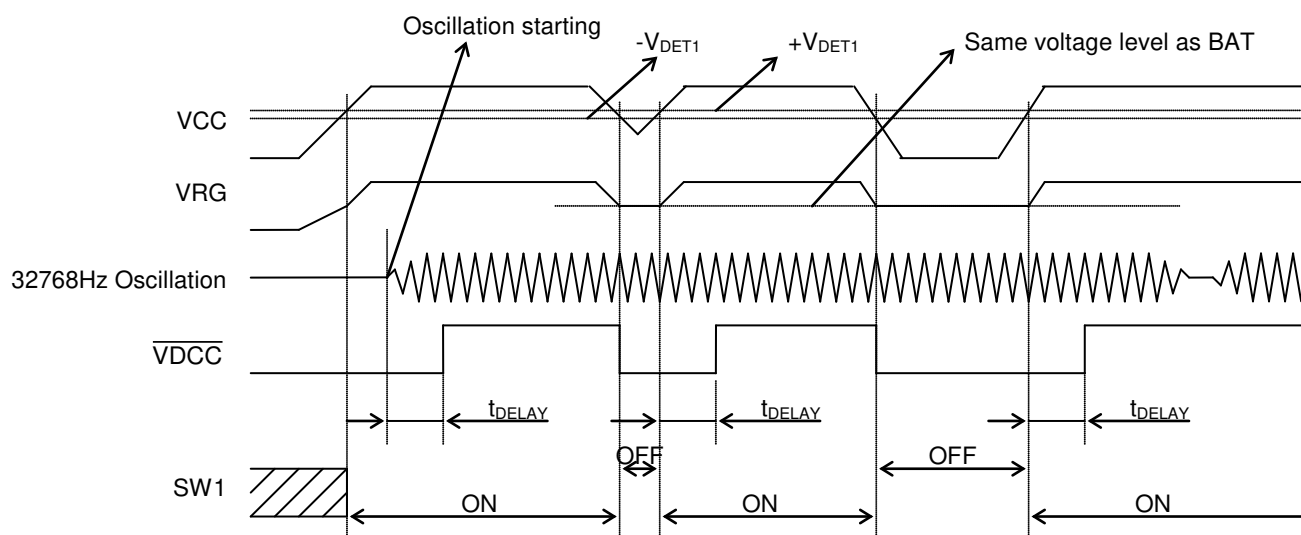

## BATTERY SWITCHOVER CIRCUIT

The R2262x incorporates three power supply pins, VCC, VRG, and BAT.

VRG pin is the internal power supply pin for the real time clock circuit.

When VCC voltage is higher than +VDET1, power is supplied from VCC to VRG via SW1. At the same time, the power is supplied from VRG to BAT via SW2. A series regulator is built in between VCC and VRG, and VRG outputs specified value, VRGOUT. Under the condition which is mentioned above, if SW2C bit is "1", then SW2 turns off and current between VRG and BAT can be stopped. However, there is a parasitic diode between BAT and VRG, therefore, if the voltage difference between BAT and VRG is 0.3V or more, regardless of the condition of SW2C bit, current flows from BAT to VRG. While VCC voltage is less than -VDET1, SW1 turns off and the power supplies from BAT to VRG via SW2 and SW2 turns on regardless of the condition of SW2C bit.

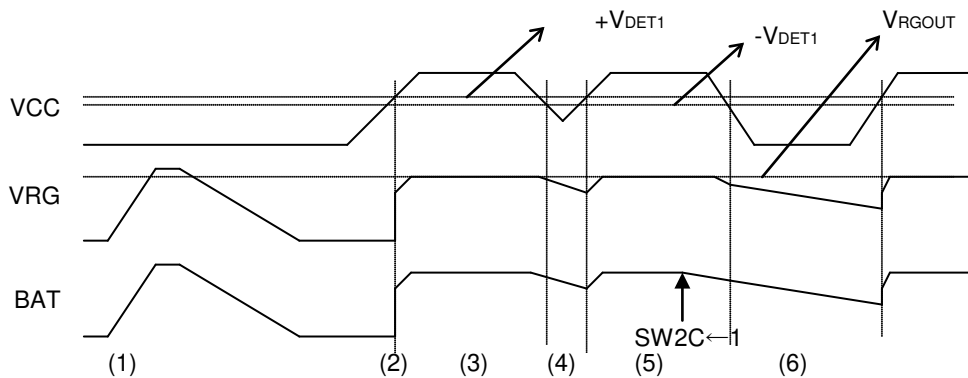

- (1) When both BAT and VCC are 0V, if BAT is made ramp up, VRG follows BAT voltage level via SW2. SW1 is still off.
- (2) When both BAT and VCC are 0V, if VCC is made ramp up, from when VCC exceeds -VDET1, power is supplied from VRG.
- (3) When VCC exceeds +VDET1, VRG reaches to VCC voltage, and finally becomes up to VRGOUT. While VCC is higher than -VDET1, VRG does not exceed VRGOUT due to the internal regulator.
- (4) When VCC becomes lower than -VDET1, power is supplied from BAT to VRG.
- (5) After VCC exceeds +VDET1, if SW2C bit is set as "1", SW2 turns off and current from VRG to BAT will stop.
- (6) As long as SW2C=1, even if the VCC becomes lower than -VDET1, SW2 turns on.

## ALARM AND PERIODIC INTERRUPT

The R2262x incorporates the alarm interrupt circuit and the periodic interrupt circuit that are configured to generate alarm signals and periodic interrupt signals for output from the  $\overline{\text{INTR}}$  pin as described below. Except R2262Txx.

### (1) Alarm Interrupt Circuit

The alarm interrupt circuit is configured to generate alarm signals for output from the  $\overline{\text{INTR}}$  pin, which is driven low (enabled) upon the occurrence of a match between current time read by the time counters (the day-of-week, hour, and minute counters) and alarm time preset by the alarm registers (the Alarm\_W registers intended for the day-of-week, hour, and minute digit settings and the Alarm\_D registers intended for the hour and minute digit settings).

### (2) Periodic Interrupt Circuit

The periodic interrupt circuit is configured to generate either clock pulses in the pulse mode or interrupt signals in the level mode for output from the  $\overline{\text{INTR}}$  pin depending on the CT2, CT1, and CT0 bit settings in the control register 1.

The above two types of interrupt signals are monitored by the flag bits (i.e. the WAFG, DAFG, and CTFG bits in the Control Register 2) and enabled or disabled by the enable bits (i.e. the WALE, DALE, CT2, CT1, and CT0 bits in the Control Register 1) as listed in the table below.

	Flag bits	Enable bits
Alarm_W	WAFG (D1 at Address Fh)	WALE (D7 at Address Eh)
Alarm_D	DAFG (D0 at Address Fh)	DALE (D6 at Address Eh)
Periodic Interrupt	CTFG (D2 at Address Fh)	CT2=CT1=CT0=0 (These bit setting of "0" disable the Periodic interrupt) (D2 to D0 at Address Eh)

\* At power-on, when the WALE, DALE, CT2, CT1, and CT0 bits are set to 0 in the Control Register 1, the  $\overline{\text{INTR}}$  pin is driven high (disabled).

\* When two types of interrupt signals are output simultaneously from the  $\overline{\text{INTR}}$  pin, the output becomes an OR waveform of their negative logic.

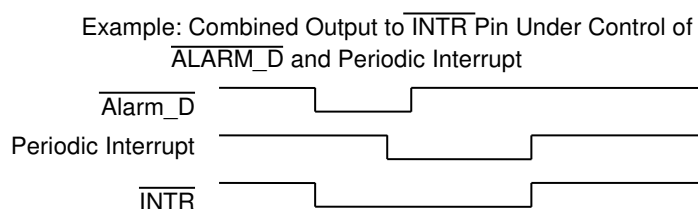

In this event, which type of interrupt signal is output from the  $\overline{\text{INTR}}$  pin can be confirmed by reading the DAFG, and CTFG bit settings in the Control Register 2.

**Alarm Interrupt**

The alarm interrupt circuit is controlled by the enable bits (i.e. the WALE and DALE bits in the Control Register 1) and the flag bits (i.e. the WAFG and DAFG bits in the Control Register 2). The enable bits can be used to enable this circuit when set to 1 and to disable it when set to 0. When intended for reading, the flag bits can be used to monitor alarm interrupt signals. When intended for writing, the flag bits will cause no event when set to 1 and will drive high (disable) the alarm interrupt circuit when set to 0.

The enable bits will not be affected even when the flag bits are set to 0. In this event, therefore, the alarm interrupt circuit will continue to function until it is driven low (enabled) upon the next occurrence of a match between current time and preset alarm time.

The alarm function can be set by presetting desired alarm time in the alarm registers (the Alarm\_W Registers for the day-of-week digit settings and both the Alarm\_W Registers and the Alarm\_D Registers for the hour and minute digit settings) with the WALE and DALE bits once set to 0 and then to 1 in the Control Register 1. Note that the WALE and DALE bits should be once set to 0 in order to disable the alarm interrupt circuit upon the coincidental occurrence of a match between current time and preset alarm time in the process of setting the alarm function.

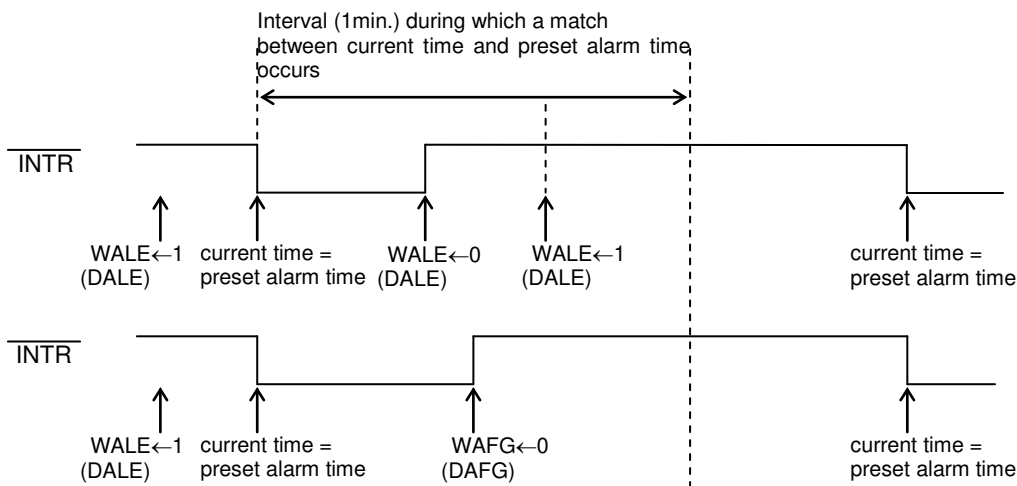

After setting WALE (DALW) to 0, Alarm registers is set to current time, and WALE (DALE) is set to 1,  $\overline{\text{INTR}}$  will be not driven to "L" immediately,  $\overline{\text{INTR}}$  will be driven to "L" at next alarm setting time.

**Periodic Interrupt**

Setting of the periodic selection bits (CT2 to CT0) enables periodic interrupt to the CPU. There are two waveform modes: pulse mode and level mode. In the pulse mode, the output has a waveform duty cycle of around 50%. In the level mode, the output is cyclically driven low and, when the CTFG bit is set to 0, the output is return to High (OFF).

CT2	CT1	CT0	Description		
			Wave Form Mode	Interrupt Cycle and Falling Timing	
0	0	0	-	OFF(H)	(Default)
0	0	1	-	Fixed at "L"	
0	1	0	Pulse Mode	2Hz(Duty50%)	
0	1	1	Pulse Mode	1Hz(Duty50%)	
1	0	0	Level Mode	Once per 1 second (Synchronized with Second counter increment)	
1	0	1	Level Mode	Once per 1 minute (at 00 seconds of every Minute)	
1	1	0	Level Mode	Once per hour (at 00 minutes and 00 Seconds of every hour)	
1	1	1	Level Mode	Once per month (at 00 hours, 00 minutes, and 00 seconds of first day of every month)	

### Pulse Mode:

2-Hz and 1-Hz clock pulses are output in synchronization with the increment of the second counter as illustrated in the timing chart below.

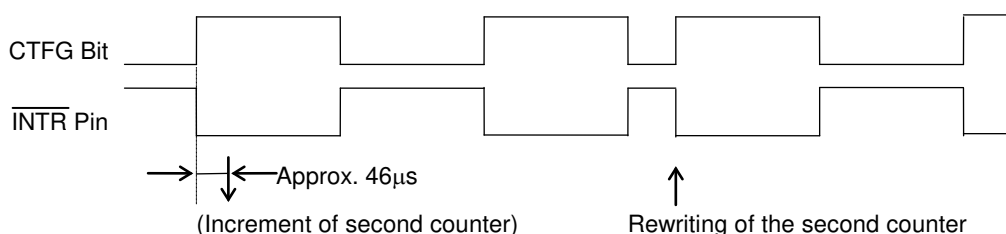

In the pulse mode, the increment of the second counter is delayed by approximately 46  $\mu$ s from the falling edge of clock pulses. Consequently, time readings immediately after the falling edge of clock pulses may appear to lag behind the time counts of the real-time clocks by approximately 1 second. Rewriting the second counter will reset the other time counters of less than 1 second, driving the  $\overline{\text{INTR}}$  pin low.

### Level Mode:

Periodic interrupt signals are output with selectable interrupt cycle settings of 1 second, 1 minute, 1 hour, and 1 month. The increment of the second counter is synchronized with the falling edge of periodic interrupt signals. For example, periodic interrupt signals with an interrupt cycle setting of 1 second are output in synchronization with the increment of the second counter as illustrated in the timing chart below.

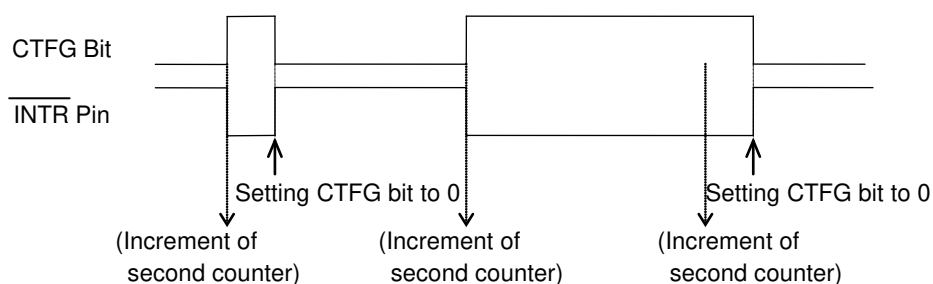

---

## R2262x

---

NO.EA-226-160701

When the oscillation adjustment circuit is used, the interrupt cycle will fluctuate once per 20sec. as follows:

**Pulse Mode:** The "L" period of output pulses will increment or decrement by a maximum of  $\pm 3.784$ ms. For example, 1-Hz clock pulses will have a duty cycle of  $50 \pm 0.3784\%$ .

**Level Mode:** A periodic interrupt cycle of 1 second will increment or decrement by a maximum of  $\pm 3.784$  ms.

## TYPICAL APPLICATIONS

### Typical Power Circuit Configurations

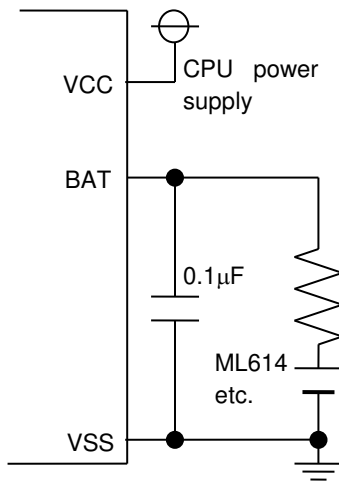

In the case of back-up by capacitor or secondary battery  
(Charging voltage is equal to CPU power supply voltage)

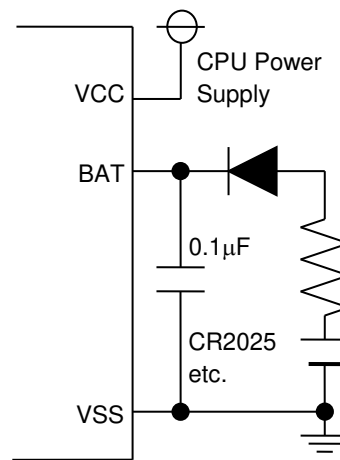

In the case of back-up by primary battery

VRG pin cannot be connected to any additional heavy load components such as SRAM. And VRG pin must be connected C2, and C2 should be over 0.1 μF.

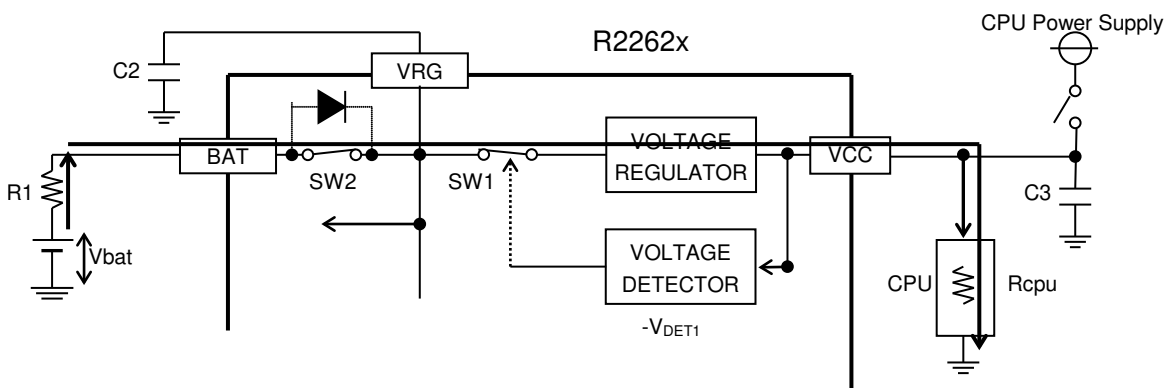

When secondary battery or double layer capacitor connects to BAT pin, after CPU power supply turning off, secondary battery discharges through the root above figure. If R1 is much smaller than CPU impedance ( $R_{CPU}$ ), VCC voltage keeps higher than  $-V_{DET1}$ , and SW1 keeps on. Therefore R1 must be specified by following formula.

$$R1 > R_{CPU} \times (V_{BAT} - (-V_{DET1})) / (-V_{DET1})$$

R1 is specified by back-up battery or double layer capacitor, too. Please check the data sheet for back-up devices.

### Connection of $\overline{INTR}$ Pin (Except R2262Txx) and $\overline{VDCC}$ Pin

The  $\overline{INTR}$  and the  $\overline{VDCC}$  pins follow the N-channel open drain output logic and contains no protective diode on the power supply side. As such, it can be connected to a pull-up resistor of up to 5.5 volts regardless of supply voltage.

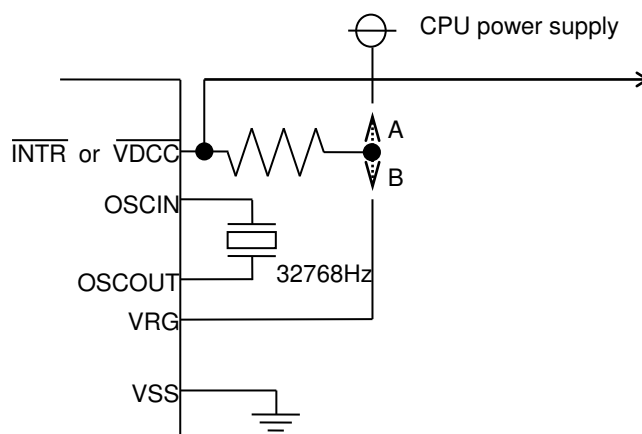

Depending on whether the  $\overline{INTR}$  and the  $\overline{VDCC}$  pins are to be used during battery backup, it should be connected to a pull-up resistor at the following different positions:

- (1) Position A in the left diagram when it is not to be used during battery backup.
- (2) Position B in the left diagram when it is to be used during battery backup.

## TYPICAL CHARACTERISTICS

Time keeping current ( $I_{BAT}$ ) vs. Supply voltage (BAT)  
 (Ta=25°C, Vcc=0V, CGout=CDout=0pF)

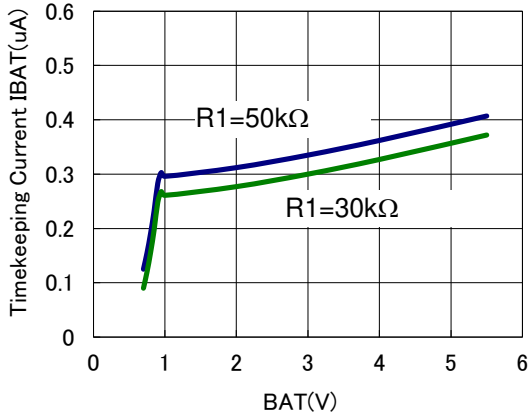

Stand-by current ( $I_{CC}$ ) vs. Supply voltage ( $V_{CC}$ )  
 (Ta=25°C, BAT=OPEN)

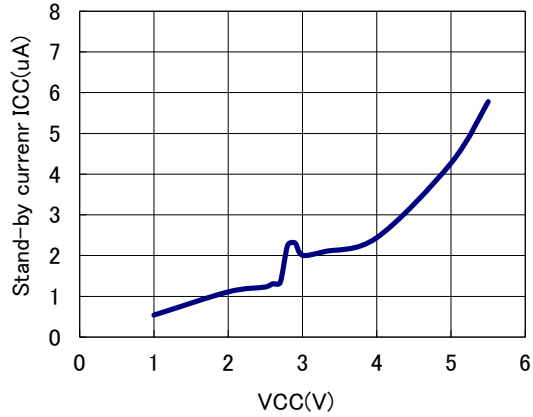

Time keeping current ( $I_{BAT}$ ) vs. Operating Temperature (Ta)  
 (BAT=3V, Vcc=0V, CGout=CDout=0pF)

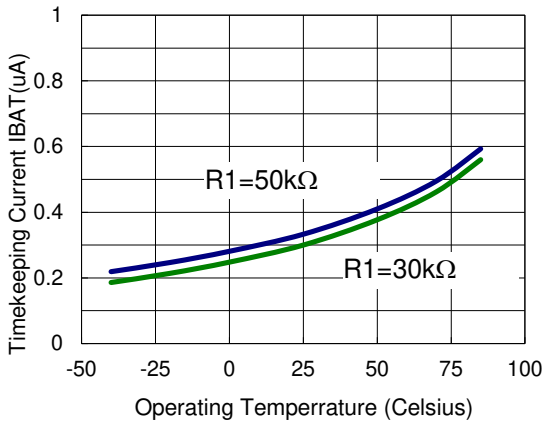

Stand-by current ( $I_{CC}$ ) vs. Operating Temperature (Ta)  
 (Vcc=3.3V, BAT=OPEN)

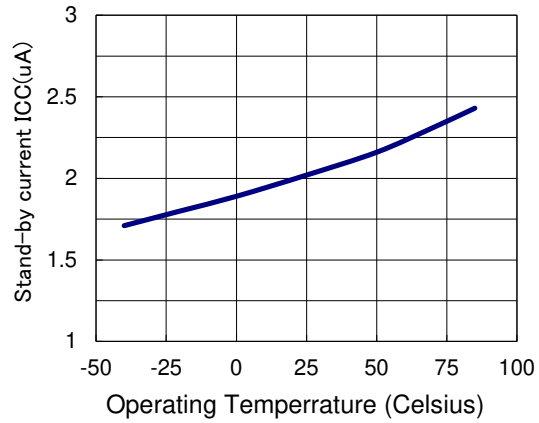

CPU access current vs. SCLK clock frequency (kHz)  
 (Ta=25°C)

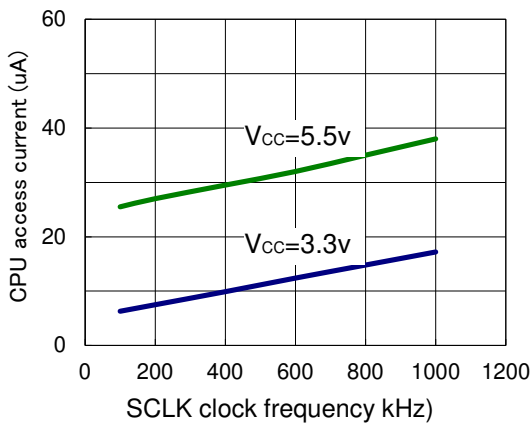

Oscillation frequency deviation ( $\Delta f/f_0$ ) vs. Operating temperature (Ta)  
 (Vcc=3V Ta=25°C as standard)

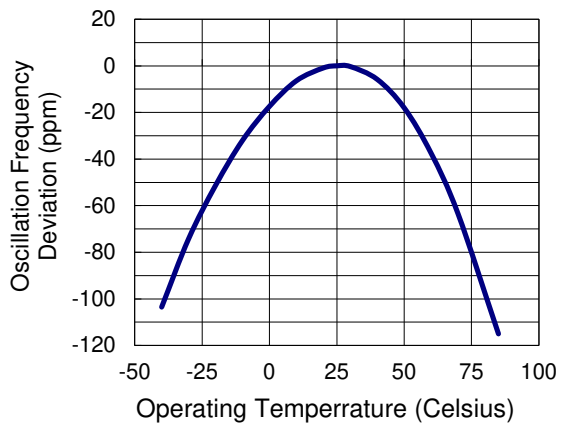



Frequency deviation ( $\Delta f/f_0$ ) vs. Supply voltage  
( $T_a=25^\circ\text{C}$ )  $V_{CC}=3\text{V}$  as standard

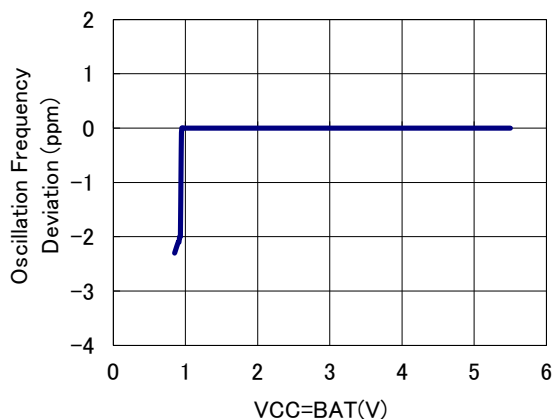

Frequency deviation ( $\Delta f/f_0$ ) vs. CGOUT  
( $T_a=25^\circ\text{C}$ ,  $V_{CC}=3\text{V}$ )  $\text{CGOUT}=0\text{pF}$  as standard

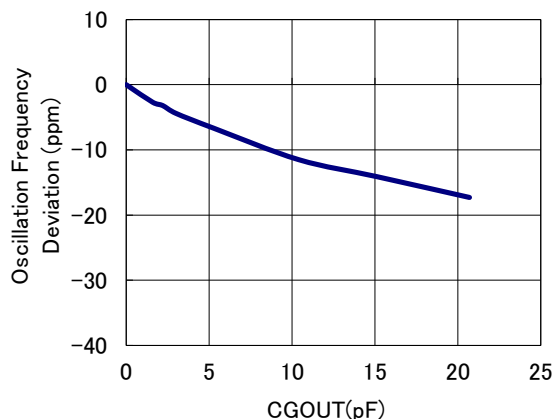

Detector threshold voltage ( $+V_{DET1}/-V_{DET1}$ ) vs. Operating temperature ( $T_a$ ) (R2262L01)

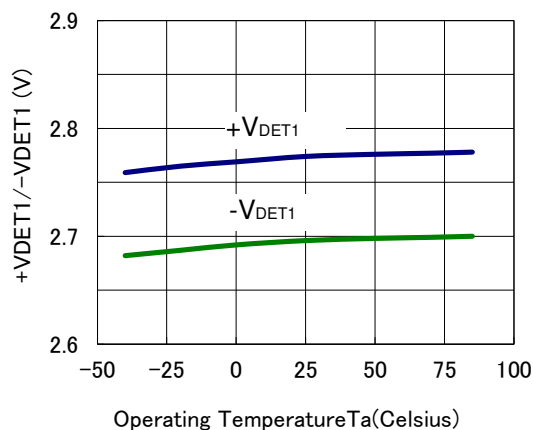

$V_{RG}$  vs. Output load current ( $I_{OUT:VRG}$ )  
( $T_a=25^\circ\text{C}$ )

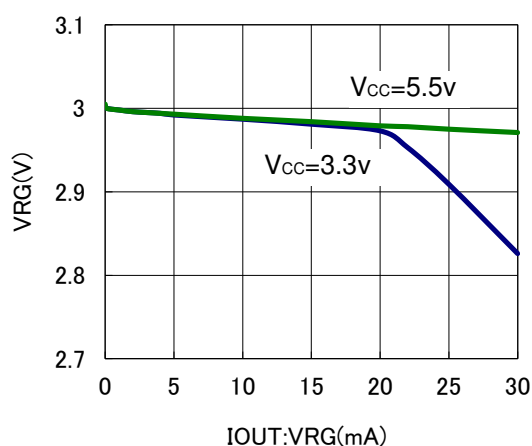

$V_{RG}$  vs. Operating temperature ( $T_a$ )  
( $V_{CC}=3.3\text{V}$ )

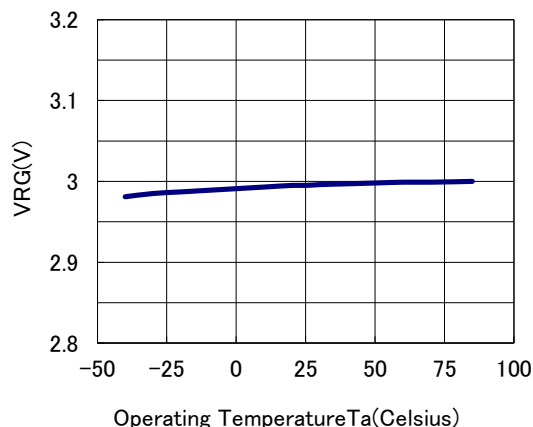

$V_{CC}$  vs.  $V_{RG}$   
( $I_{OUT}=0.1\text{mA}$ ,  $T_a=25^\circ\text{C}$ )

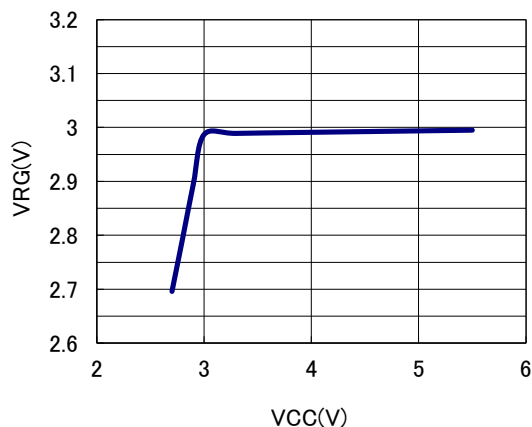

---

**R2262x**

---

NO.EA-226-160701

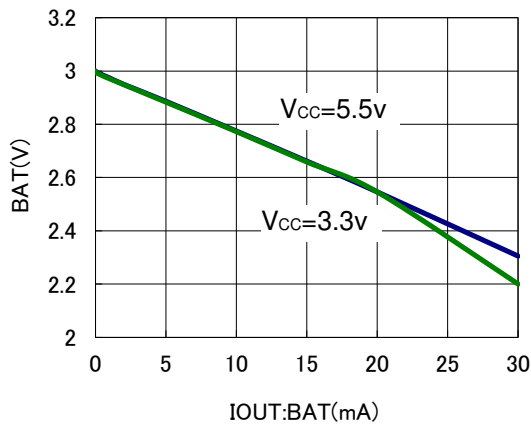
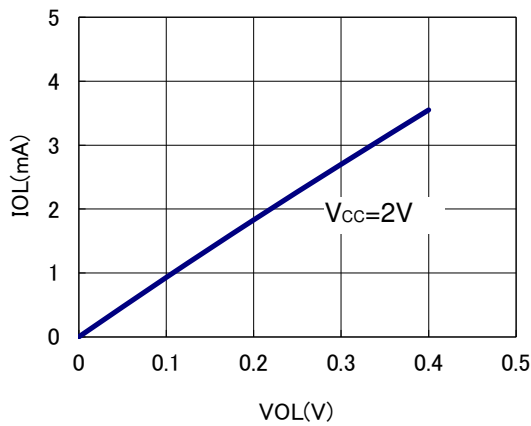
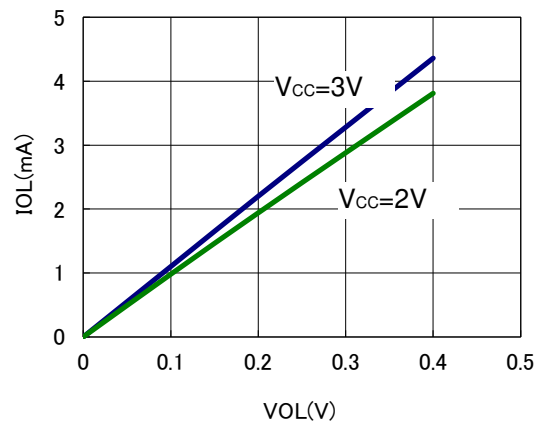
BAT vs. Output load Current ( $I_{OUT:BAT}$ )  
( $T_a=25^\circ\text{C}$ ) $V_{OL}$  vs.  $I_{OL}$  ( $\overline{VDCC}$  pin)  
( $T_a=25^\circ\text{C}$ ,  $V_{CC}=2\text{V}$ ) $V_{OL}$  vs.  $I_{OL}$  ( $\overline{INTR}$  pin) (Except R2262Txx)  
( $T_a=25^\circ\text{C}$ )

## TYPICAL SOFTWARE-BASED OPERATIONS

### Initialization at Power-on

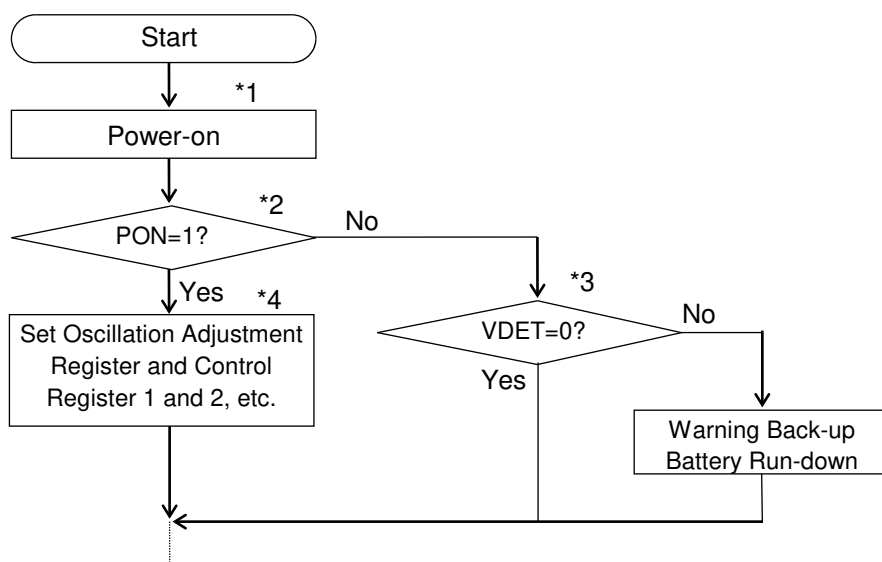

\*1 After power-on from 0 volt, the process of internal initialization require a time span on 1sec, so that access should be done after  $\overline{\text{VDCC}}$  turning to OFF (H).

\*2 The PON bit setting of 0 in the Control Register 1 indicates power-on from backup battery and not from 0V. For further details, see "PON, XSTP, and VDET in Power-on Reset, Oscillation Halt Sensing, and Supply Voltage Monitoring".

\*3 This step is not required when the supply voltage monitoring circuit is not used. When using this circuit, note as follows.

After writing to the second counter, reset a VDET flag (writing 0) once for defining a value of VDET flag.

\*4 This step involves ordinary initialization including the Oscillation Adjustment Register and interrupt cycle settings, etc.

### Writing of Time and Calendar Data

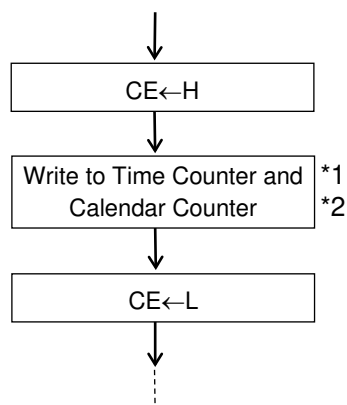

\*1 When writing to clock and calendar counters, do not insert CE=L until all times from second to year have been written to prevent error in writing time. (Detailed in "Considerations in Reading and Writing Time Data under special condition".)

\*2 After writing to the second counter, reset a VDET flag (writing 0) once for defining a value of VDET flag.

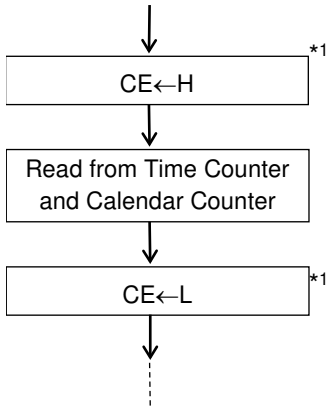
**Reading Time and Calendar Data****(1) Ordinary Process of Reading Time and Calendar Data**

\*1 When reading to clock and calendar counters, do not insert CE=L until all times from second to year have been read to prevent error in reading time. (Detailed in "Considerations in Reading and Writing Time Data under special condition".

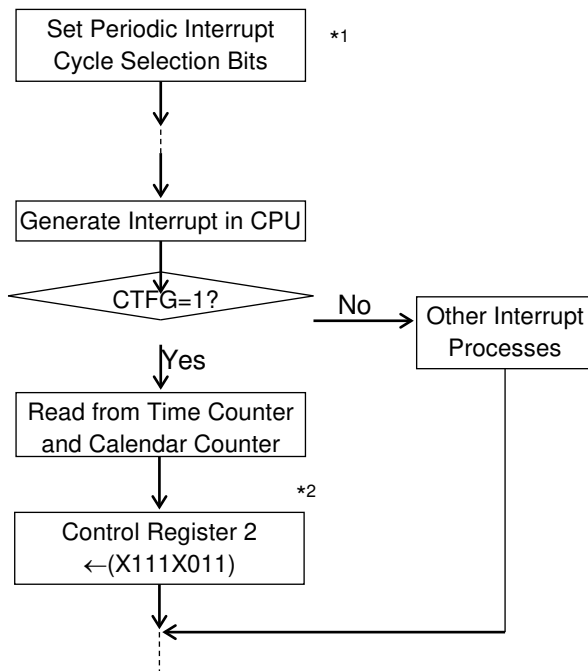
**(2) Basic Process of Reading Time and Calendar Data with Periodic Interrupt Function (Except R2262Txx)**

\*1 This step is intended to select the level mode as a waveform mode for the periodic interrupt function.

\*2 This step is intended to set the CTFG bit to 0 in the Control Register 2 to cancel an interrupt to the CPU.

**(3) Applied Process of Reading Time and Calendar Data with Periodic Interrupt Function (Except R2262T)**

Time data need not be read from all the time counters when used for such ordinary purposes as time count indication. This applied process can be used to read time and calendar data with substantial reductions in the load involved in such reading.

For Time Indication in "Day-of-Month, Day-of-week, Hour, Minute, and Second" Format:

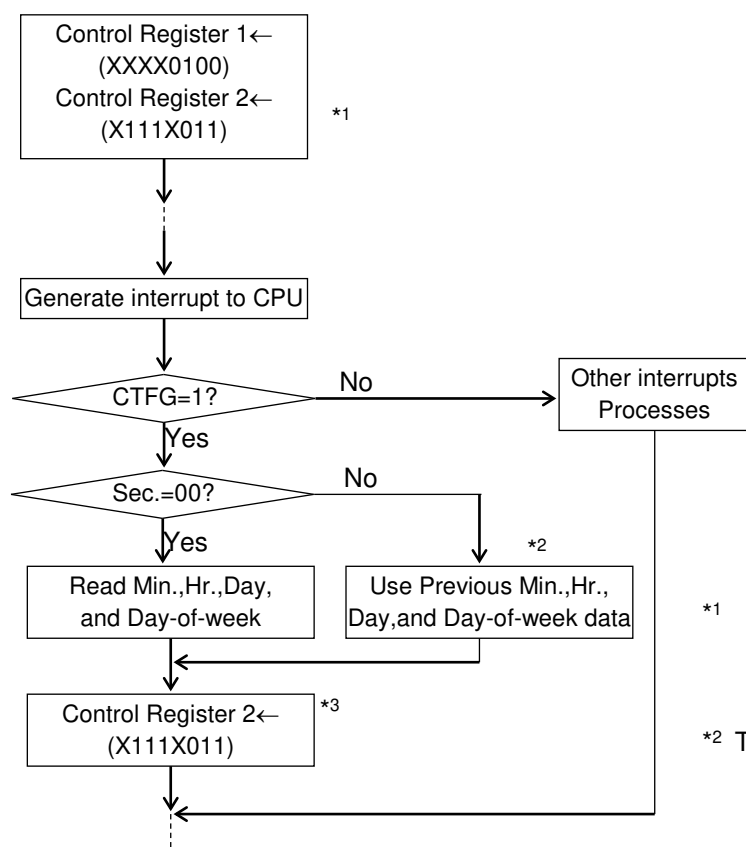

\*1 This step is intended to select the level mode as a waveform mode for the periodic interrupt function.

\*2 This step is intended to read time data from all the time counters only in the first session of reading time data after writing time data.

\*3 This step is intended to set the CTFG bit to 0 in the Control Register 2 to cancel an interrupt to the CPU.

**Interrupt Process**

**(1) Periodic Interrupt (Except R2262Txx)**

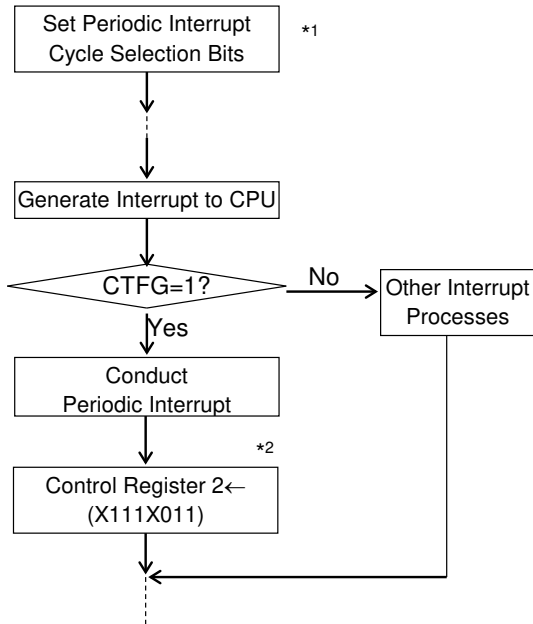

- \*1 This step is intended to select the level mode as a waveform mode for the periodic interrupt function.
- \*2 This step is intended to set the CTFG bit to 0 in the Control Register 2 to cancel an interrupt to the CPU.

**(2) Alarm Interrupt (Except R2262Txx)**

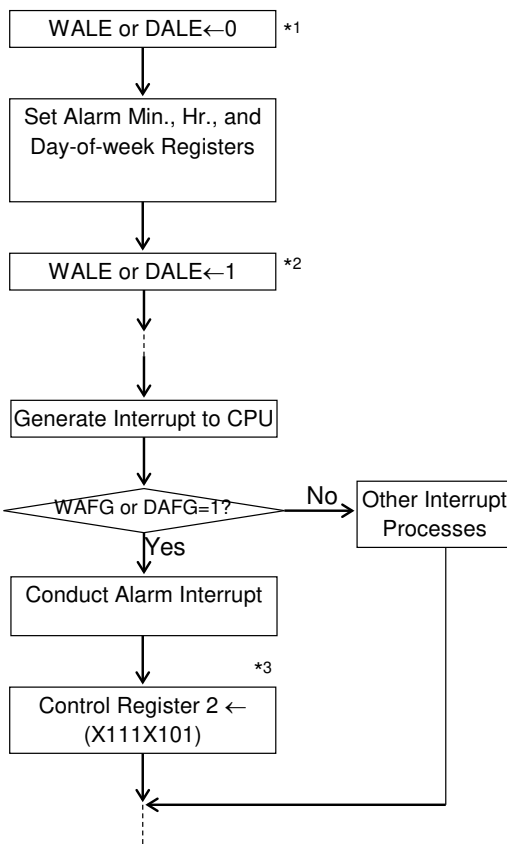

- \*1 This step is intended to once disable the alarm interrupt circuit by setting the WALE or DALE bits to 0 in anticipation of the coincidental occurrence of a match between current time and preset alarm time in the process of setting the alarm interrupt function.
- \*2 This step is intended to enable the alarm interrupt function after completion of all alarm interrupt settings.
- \*3 This step is intended to once cancel the alarm interrupt function by writing the settings of "X,1,1,1,X,1,0,1" and "X,1,1,1,X,1,1,0" to the Alarm\_W Registers and the Alarm\_D Registers, respectively.



1. The products and the product specifications described in this document are subject to change or discontinuation of production without notice for reasons such as improvement. Therefore, before deciding to use the products, please refer to our sales representatives for the latest information thereon.
2. The materials in this document may not be copied or otherwise reproduced in whole or in part without prior written consent of our company.
3. Please be sure to take any necessary formalities under relevant laws or regulations before exporting or otherwise taking out of your country the products or the technical information described herein.
4. The technical information described in this document shows typical characteristics of and example application circuits for the products. The release of such information is not to be construed as a warranty of or a grant of license under our company's or any third party's intellectual property rights or any other rights.
5. The products listed in this document are intended and designed for use as general electronic components in standard applications (office equipment, telecommunication equipment, measuring instruments, consumer electronic products, amusement equipment etc.). Those customers intending to use a product in an application requiring extreme quality and reliability, for example, in a highly specific application where the failure or misoperation of the product could result in human injury or death (aircraft, spacevehicle, nuclear reactor control system, traffic control system, automotive and transportation equipment, combustion equipment, safety devices, life support system etc.) should first contact us.
6. We are making our continuous effort to improve the quality and reliability of our products, but semiconductor products are likely to fail with certain probability. In order to prevent any injury to persons or damages to property resulting from such failure, customers should be careful enough to incorporate safety measures in their design, such as redundancy feature, fire containment feature and fail-safe feature. We do not assume any liability or responsibility for any loss or damage arising from misuse or inappropriate use of the products.
7. Anti-radiation design is not implemented in the products described in this document.
8. The X-ray exposure can influence functions and characteristics of the products. Confirm the product functions and characteristics in the evaluation stage.
9. WLCSP products should be used in light shielded environments. The light exposure can influence functions and characteristics of the products under operation or storage.
10. There can be variation in the marking when different AOI (Automated Optical Inspection) equipment is used. In the case of recognizing the marking characteristic with AOI, please contact our sales or our distributor before attempting to use AOI.
11. Please contact our sales representatives should you have any questions or comments concerning the products or the technical information.



**Nisshinbo Micro Devices Inc.**

**Official website**

<https://www.nisshinbo-microdevices.co.jp/en/>

**Purchase information**

<https://www.nisshinbo-microdevices.co.jp/en/buy/>

