

REVISIONS				
P	LTR	DESCRIPTION	DATE	APPD
A3		REVISED PER ECR-19-009363	20JUN2019	ED RS

- USE INSTRUCTION SHEET 408-9089
- MAXIMUM PANEL THICKNESS: 6.10 [.240]
- DIELECTRIC MUST WITHSTAND A 6 POUND PUSHOUT FORCE
- USE WITH CRIMP TOOL 354940-1.
- USE WITH CRIMP TOOL 220190-1

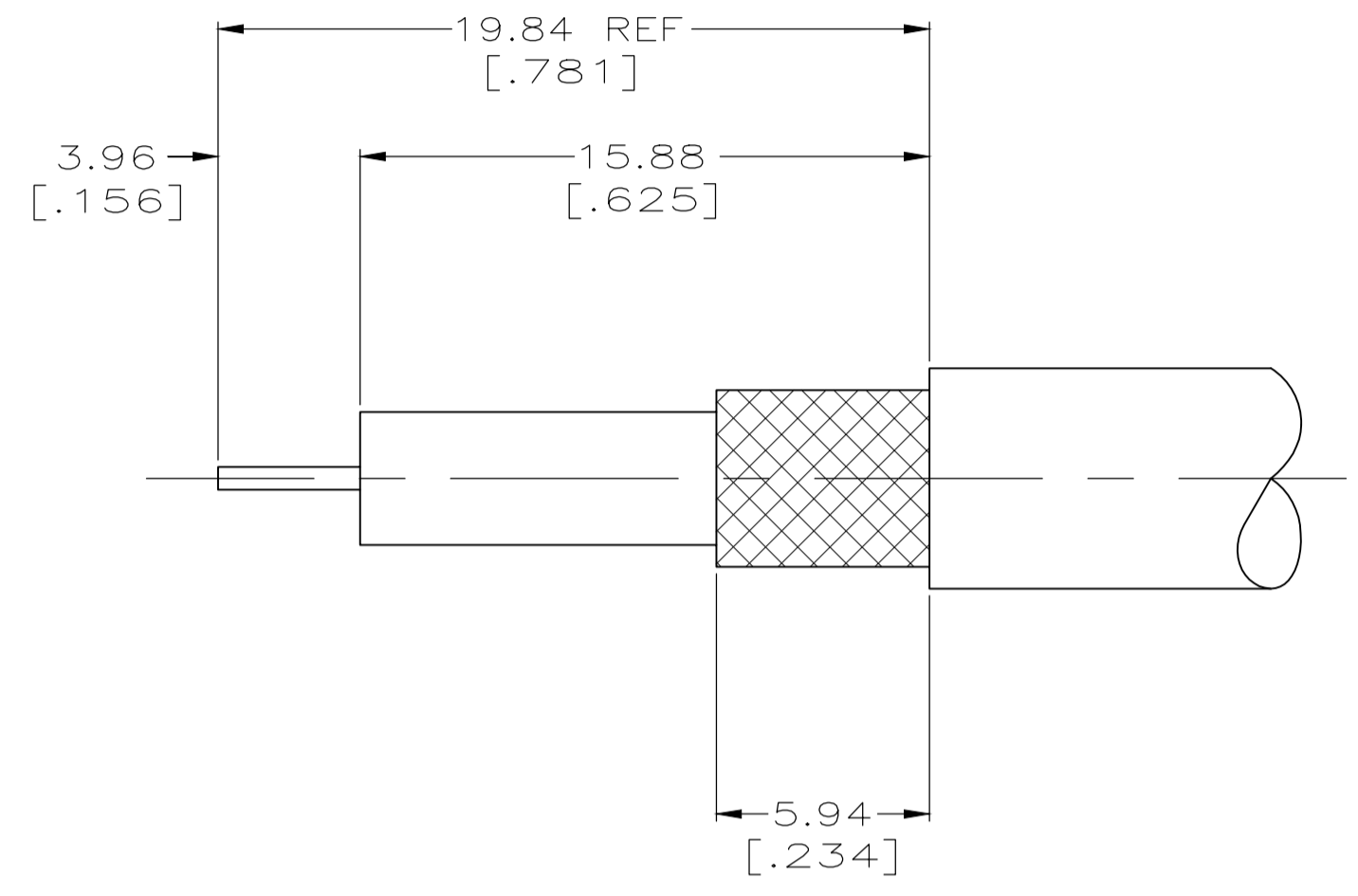

RECOMMENDED STRIP LENGTH

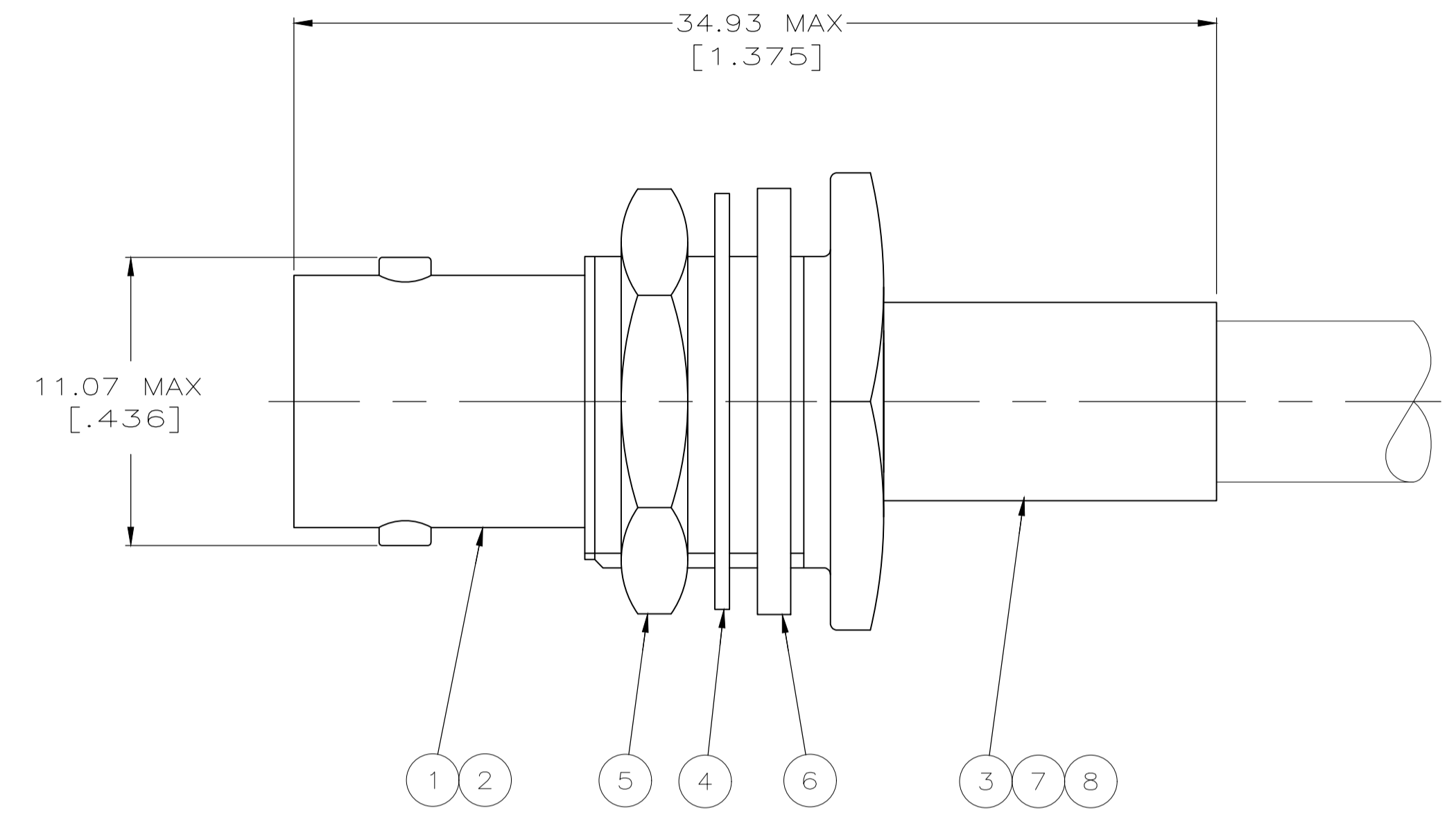
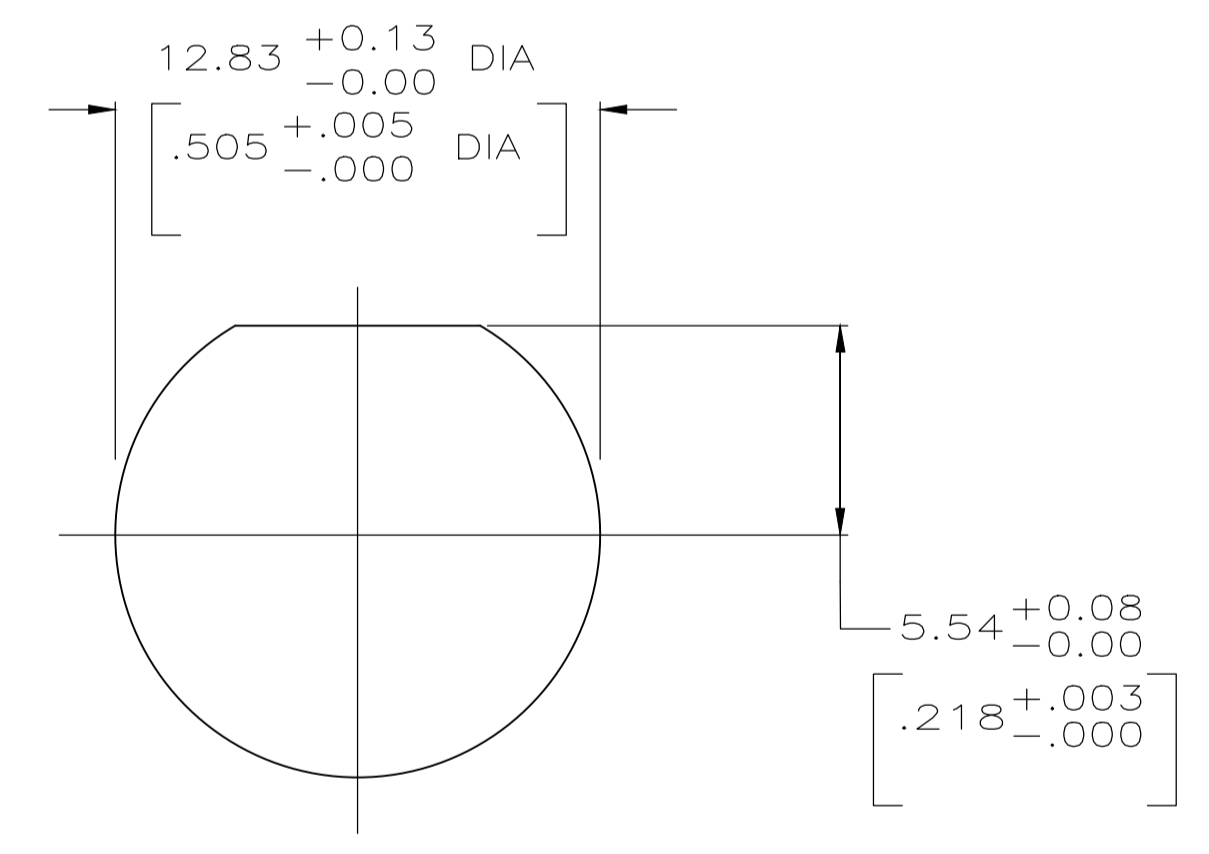

RECOMMENDED PANEL CUTOUT

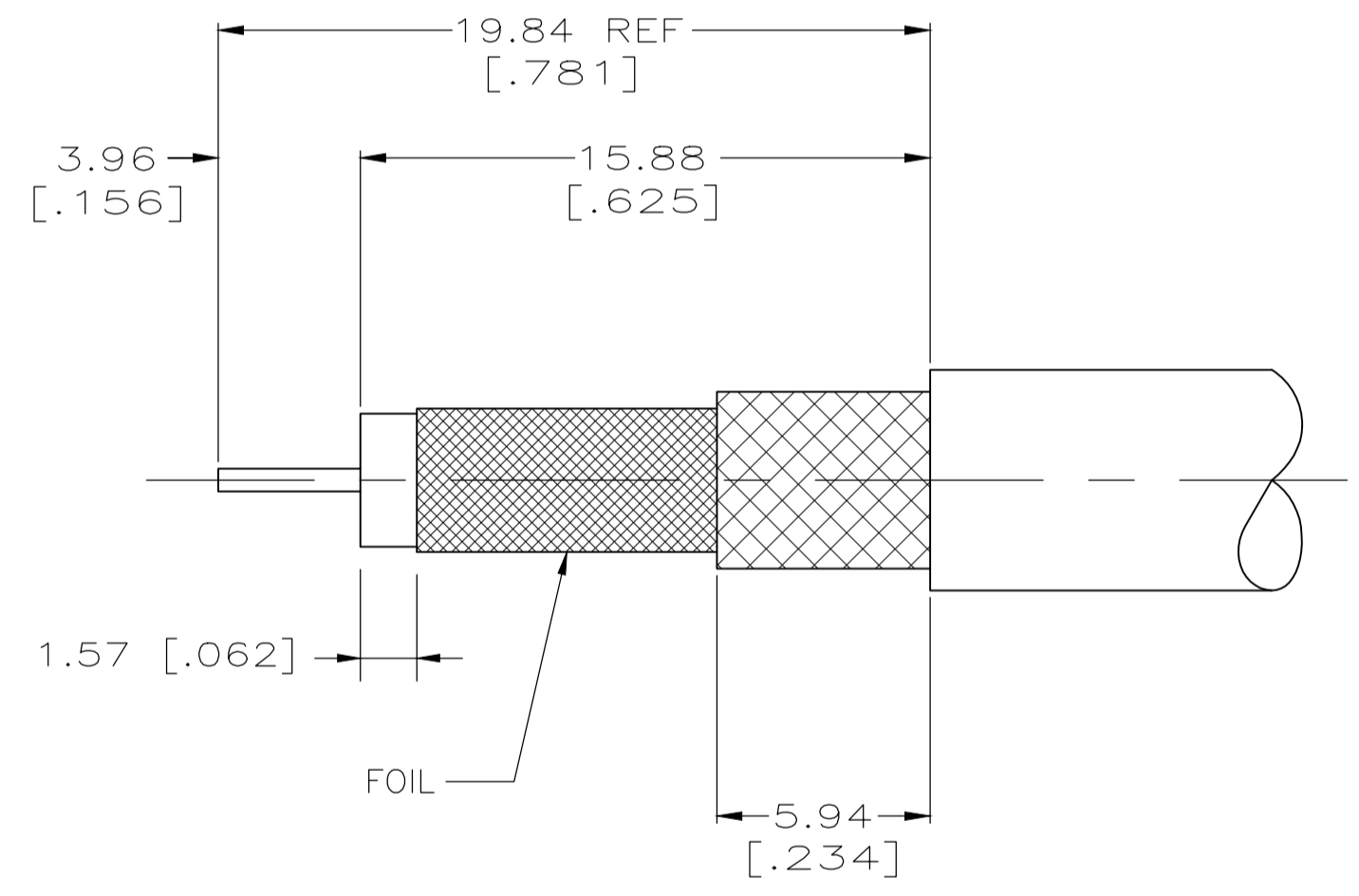

RECOMMENDED STRIP LENGTH FOR 5221221-9

△	AT&T 735A	58174-1	-	-	329633	1-1403077-9	1-329632-2	9-328666-2	221200-9	221255-3	5221221-9
△	BELDEN 9240, 9259, 9266	58085-1	-	-	329633	1-329631-2	1-329632-2	9-50428-0	2-221200-5	221255-2	5221221-7
△	RG-179/U, 179A/U, 179B/U, 187/U, 187A/U	58304-1	227194-2	222001-6	329633	1-329631-2	1-329632-2	9-328666-0	2-221200-0	221255-3	5221221-5
△	RG-59/U, 59A/U, 59B/U	58085-1	-	-	329633	1-329631-2	1-329632-2	9-50428-0	221200-3	221255-2	5221221-2
△	BELDEN 9248 AND MADISON 18AWG	58086-1	-	-	329633	1-329631-2	1-329632-2	9-50427-0	3-221200-2	221255-1	5221221-1
	CABLE	DIE SET	⑧ TUBING, PLASTIC QTY=1	⑦ TUBING, METAL QTY=1	⑥ GASKET QTY=1	⑤ JAM NUT QTY=1	④ LOCK WASHER QTY=1	③ FERRULE QTY=1	② CONTACT QTY=1	① JACK ASSEMBLY QTY=1	PART NUMBER

THIS DRAWING IS A CONTROLLED DOCUMENT.

DIMENSIONS: mm [INCHES]	TOLERANCES UNLESS OTHERWISE SPECIFIED:	0 PLC ± -	1 PLC ± -	2 PLC ± 0.41 [016]	3 PLC ± -	4 PLC ± -	ANGLES ± -
MATERIAL	FINISH	WEIGHT	0.000000	SCALE	5:1	SHEET	1 of 1
CUSTOMER DRAWING		SIZE	A1	DRAWING NO	00779	DRAWING NO	5221221

DATE: 24 JAN 2005  
 DESIGNED BY: J. HAVENER  
 CHECKED BY: J. HAVENER  
 APPROVED BY: J. LIPPERT  
 NAME: JACK, BULKHEAD, 75 OHM, BNC  
 PRODUCT SPEC: 108-12095  
 APPLICATION SPEC: -  
 RESTRICTED TO: -  
 REV: A3